



This manual links to SMC Flex Soft Starter Parameters, publication [150-RD001](#); download the spreadsheet now for offline access.



SMC Flex Soft Starters

Bulletin 150-F



Allen-Bradley

by ROCKWELL AUTOMATION

User Manual

Original Instructions

Important User Information

Read this document and the documents listed in the additional resources section about installation, configuration, and operation of this equipment before you install, configure, operate, or maintain this product. Users are required to familiarize themselves with installation and wiring instructions in addition to requirements of all applicable codes, laws, and standards.

Activities including installation, adjustments, putting into service, use, assembly, disassembly, and maintenance are required to be carried out by suitably trained personnel in accordance with applicable code of practice.

If this equipment is used in a manner not specified by the manufacturer, the protection provided by the equipment may be impaired.

In no event will Rockwell Automation, Inc. be responsible or liable for indirect or consequential damages resulting from the use or application of this equipment.

The examples and diagrams in this manual are included solely for illustrative purposes. Because of the many variables and requirements associated with any particular installation, Rockwell Automation, Inc. cannot assume responsibility or liability for actual use based on the examples and diagrams.

No patent liability is assumed by Rockwell Automation, Inc. with respect to use of information, circuits, equipment, or software described in this manual.

Reproduction of the contents of this manual, in whole or in part, without written permission of Rockwell Automation, Inc., is prohibited.

Throughout this manual, when necessary, we use notes to make you aware of safety considerations.



WARNING: Identifies information about practices or circumstances that can cause an explosion in a hazardous environment, which may lead to personal injury or death, property damage, or economic loss.



ATTENTION: Identifies information about practices or circumstances that can lead to personal injury or death, property damage, or economic loss. Attentions help you identify a hazard, avoid a hazard, and recognize the consequence.

IMPORTANT

Identifies information that is critical for successful application and understanding of the product.

These labels may also be on or inside the equipment to provide specific precautions.



SHOCK HAZARD: Labels may be on or inside the equipment, for example, a drive or motor, to alert people that dangerous voltage may be present.



BURN HAZARD: Labels may be on or inside the equipment, for example, a drive or motor, to alert people that surfaces may reach dangerous temperatures.



ARC FLASH HAZARD: Labels may be on or inside the equipment, for example, a motor control center, to alert people to potential Arc Flash. Arc Flash will cause severe injury or death. Wear proper Personal Protective Equipment (PPE). Follow ALL Regulatory requirements for safe work practices and for Personal Protective Equipment (PPE).

The following icon may appear in the text of this document.



Identifies information that is useful and can help to make a process easier to do or easier to understand.

Product Overview

Preface

About This Publication	7
Terminology.....	7
View Parameters.....	7
Summary of Changes.....	7
Additional Resources	8

Chapter 1

Operation.....	9
Starting Modes	9
Soft Start	10
Linear Speed Acceleration.....	10
Current Limit Start	11
Selectable Kickstart	11
Pump Control Mode.....	12
Dual Ramp Start	12
Full-voltage Start.....	13
Preset Slow Speed	13
Stopping Modes.....	14
Coast.....	14
Soft Stop.....	14
Linear Speed Deceleration ^(a)	14
Pump Stop ^(a)	15
Braking Control Modes.....	16
Smart Motor Braking (SMB) ^(a)	16
Slow Speed with Braking	16
Accu-Stop ^(b)	17
Protection and Diagnostics.....	17
Overload.....	17
Underload.....	17
Undervoltage.....	19
Overvoltage ^(a)	19
Unbalance ^(a)	19
Stall Protection and Jam Detection	19
Ground Fault	21
Ground Fault Trip	22
Ground Fault Alarm.....	22
Thermistor/PTC Protection	22
Excessive Starts/Hour	23
Overtemperature.....	23
Open Gate.....	24
Line Faults	24
Metering.....	24
I/O.....	24
Communication.....	25
Programming.....	25
Status Indication.....	25

Installation**Chapter 2**

Receive the Controller	27
Unpack the Controller	27
Inspect the Controller.....	27
Storage.....	27
Lifting.....	27
General Precautions	28
Degree of Protection	28
Heat Dissipation	29
Enclosures.....	29
Mounting	30
Power Factor Correction Capacitors	31
Protective Modules.....	32
Motor Overload Protection.....	32
Two-speed Motors.....	32
Multi-motor Protection.....	32
Electromagnetic Compatibility (EMC).....	32
Enclosure	32
Wiring	32
Additional Requirements	33
New EMC Compliance – Conducted Emissions	33

Wiring**Chapter 3**

Wiring Terminal Locations.....	35
Power Structure	37
Power Wiring	37
Line Connection	38
Delta Connection.....	38
Power Lugs	39
Control Power	40
Control Wiring	40
Controllers rated 5...480 A	40
Controllers rated 625...1250 A	41
Control Wire Specifications	43
Fan Power	44
Fan Terminations	44
Control Terminal Designations	45
Standard Controller Wiring Diagrams.....	46
Soft Stop, Pump Control, and SMB Smart Motor Braking	57
Preset Slow Speed	61
Slow Speed with Braking	63
Sequence of Operation.....	64
Special Application Considerations	70
Protective Modules	70
Multi-motor Applications	71
SMC Flex Controller as a Bypass to an AC Drive	72
SMC Flex Controller with a Bulletin 1410 Motor Winding Heater.....	73
Dual-voltage Wiring	73
Low-voltage Example	74
High-voltage Example.....	75

Programming	Chapter 4	
	Keypad Description	77
	Programming Menu	77
	Password	80
	Parameter Management	81
	Random Access Memory (RAM)	81
	Read-only Memory (ROM)	81
	Parameter Modification	82
	Soft Start	82
	Current Limit Start	83
	Dual Ramp Start	83
	Full Voltage Start	83
	Linear Speed	84
	Programming Parameters	84
	Basic Setup	85
	Motor Protection	86
	Metering	Chapter 5
View Metering Data		87
Optional HIM Operation	Chapter 6	
	Human Interface Module	89
Communication	Chapter 7	
	Communication Ports	91
	Human Interface Module	91
	Keypad Descriptions	92
	Connect the Human Interface Module to the Controller	92
	Control Enable	93
	HIM and COMM Card Control Enable	94
	Loss of Communication and Network Faults	95
	SMC Flex Controller-specific Information	95
	Default Input/Output Configuration	95
	Variable Input/Output Configuration	95
	Bit Identification	96
	Reference/Feedback	97
	Parameter Information	97
	Scale Factors for PLC Communication	97
	Display Text Unit Equivalents	97
	Configuring DataLink	98
	Criteria for Using DataLink	98
	Updating Firmware	98
Diagnostic Capabilities	Chapter 8	
	Protection Programming	99
	Fault Display	99
	Clear Fault	99

	Fault Buffer	100
	Fault Codes	100
	Fault and Alarm Auxiliary Indication.....	101
	Fault Definitions	101
	Chapter 9	
Troubleshooting	Power Module Check	106
	Shorted SCR Test.....	106
	Check Line Load	107
	Appendix A	
Renewal Parts	109
	Appendix B	
Renewal Parts Cross Reference	111

About This Publication

This user manual provides you with the information that is required to program and operate your SMC™ Flex soft starter.

The SMC Flex controller is modular so that it can help simplify installation and commissioning. A built-in LCD display, keypad, and flexible communications provide optimized configuration, advanced performance, diagnostics, and protection. Three-phase control, electronic overload, and integrated bypass along with removable control module, power modules, and fan assembly are combined in a cost-effective package for your demanding applications.

The user manual assumes that the installer is a qualified person with previous experience and basic understanding of electrical terminology, configuration procedures, required equipment, and safety precautions.

For safety of maintenance personnel and others who might be exposed to electrical hazards associated with maintenance activities, follow all local safety-related work practices (such as NFPA 70E, Part II in the United States). Maintenance personnel must be trained in the safety practices, procedures, and requirements that pertain to their respective job assignments.

Terminology

Throughout this publication, we also refer to the SMC Flex soft starter as the SMC Flex controller. These terms are interchangeable.

View Parameters

Parameter definitions are listed in Excel® spreadsheets in KnowledgeBase. The spreadsheets let you filter and sort parameters, and add your own setting values and notes. Table 1 summarizes the information that is in the spreadsheet.



This manual links to SMC Flex Soft Starter Parameters, publication [150-RD001](#); download the spreadsheet now for offline access.

Table 1 - SMC Flex Parameter Categories

Parameter Group	Description
Full Parameter List	Full list of all SMC Flex Controller Parameters
Logic Mask Requirements	Lists the Logic Mask Codes and Binary equivalents
Parameter Special Behavior	Describes codes that can appear under specific conditions and parameter configurations

Summary of Changes

This publication contains the following new or updated information. This list includes substantive updates only and is not intended to reflect all changes.

Topic	Page
Parameters spreadsheet renamed to 150-RD001	-
Updated SMC Flex Controller Line Connection Lug Information—5...1250 A Devices	39
Updated Communication Card Selection by Protocol Type	91
Updated Logic Mask (Parameter 87) Requirements	94
Updated Fault Definitions	101
Added Check Line Load guidance	107
Updated Other Renewal Parts information	110

Additional Resources

These documents contain additional information concerning related products from Rockwell Automation. You can view or download publications at rok.auto/literature.

Resource	Description
SMC Flex Soft Starter Parameters, publication 150-RD001	Provides parameter information for SMC Flex Soft Starters.
SMC-3, SMC Flex, and SMC-50 Smart Motor Controllers Technical Data, publication 150-TD009	Provides product selection and specifications information about the SMC™ family of smart motor controllers.
Bulletin 150 SMC Flex (625...1250 A) Renewal Part Instructions, publication 150-IN064	Provides instructions about installing renewal parts into SMC Flex controllers.
Enclosed SMC Controllers Selection Guide, publication 150-SG012	Provides selection information about enclosed SMC controller products.
PowerFlex™ 20-HIM-A6 and 20-HIM-C6S HIM (Human Interface Module) user manual, publication 20HIM-UM001	Provides comprehensive user information for 20-HIM human interface modules.
20-COMM-D DeviceNet Adapter user manual, publication 20COMM-UM002	Provides comprehensive user information for 20-COMM-D DeviceNet™ adapter.
20-COMM-C Series B / 20-COMM-Q Series A ControlNet Adapter user manual, publication 20COMM-UM003	Provides comprehensive user information for 20-COMM-C ControlNet and 20-COMM-Q ControlNet (Fiber) adapters.
20-COMM-P Profibus® Adapter user manual, publication 20COMM-UM006	Provides comprehensive user information for 20-COMM-P Profibus adapter.
20-COMM-S RS-485 DF1 Adapter user manual, publication 20COMM-UM005	Provides comprehensive user information for 20-COMM-S RS-485 DF1 adapter.
20-COMM-I Interbus Adapter user manual, publication 20COMM-UM007	Provides comprehensive user information for 20-COMM-I Interbus adapter.
20-COMM-H RS485 HVAC Adapter user manual, publication 20COMM-UM009	Provides comprehensive user information for 20-COMM-H RS485 HVAC adapter.
PowerFlex™ 20-COMM-E EtherNet/IP Adapter user manual, publication 20COMM-UM010	Provides comprehensive user information for 20-COMM-E EtherNet/IP™ adapter.
20-COMM-K CANopen Adapter user manual, publication 20COMM-UM012	Provides comprehensive user information for 20-COMM-K CANopen adapter.
20-COMM-ER Dual-Port EtherNet/IP™ Communication Adapter user manual, publication 20COMM-UM015	Provides comprehensive user information for 20-COMM-ER Dual-Port EtherNet/IP Communication adapter
Wiring and Ground guidelines, publication DRIVES-IN001	Provides basic information to install, protect, wire, and ground pulse-width modulated (PWM) AC drives.
Rockwell Automation Global SCCR Tool, rok.auto/sccr	Provides coordinated high-fault branch circuit solutions for motor starters, soft starters, and component drives.
Industrial Components Preventive Maintenance, Enclosures, and Contact Ratings Specifications, publication IC-TD002	Provides a quick reference tool for Allen-Bradley industrial automation controls and assemblies.
Safety Guidelines for the Application, Installation, and Maintenance of Solid-state Control, publication SGI-1.1	Designed to harmonize with NEMA Standards Publication No. ICS 1.1-1987 and provides general guidelines for the application, installation, and maintenance of solid-state control in the form of individual devices or packaged assemblies incorporating solid-state components.
Industrial Automation Wiring and Grounding Guidelines, publication 1770-4.1	Provides general guidelines for installing a Rockwell Automation industrial system.
Product Certifications website, rok.auto/certifications	Provides declarations of conformity, certificates, and other certification details.

Product Overview

The SMC™ Flex controller is modular so that it can help simplify installation and commissioning. A built-in LCD display, keypad, and flexible communications provide optimized configuration, advanced performance, diagnostics, and protection. SMC Flex controllers combine three-phase control, electronic overload, and integrated bypass along with removable control module, power modules, and fan assembly in a cost-effective package for your demanding applications.

- Modular for simplified installation and maintenance
- Built-in LCD and keypad or personal computer software setup
- Integrated bypass
- Nine start/stop modes and three slow-speed modes
- Full metering and diagnostics

Modes of operation include the following:

- Soft start
- Current Limit Start
- Selectable Kickstart
- Coast-to-rest
- Soft stop
- Smart Motor Braking (SMB™)
- Slow Speed with Braking
- Full-voltage Start
- Dual Ramp Start
- Pump Start
- Preset Slow Speed
- Pump Stop
- Accu-Stop™
- Linear Speed Acceleration (Tachometer required)

IMPORTANT The three controller options are Standard Control, Pump Control, and Brake Control. Some modes of operation are only available on certain controllers, such as Smart Motor Braking on Brake Control. Consider the available modes of operation for a controller when configuring a catalog number to order. You can upgrade an existing controller to another control option by replacing the control module. Consult your local Rockwell Automation sales office or Allen-Bradley distributor.

Operation

The SMC Flex controller can operate standard squirrel-cage induction motors rated 1...1250 A or Star-delta (wye-delta) type motors rated 1.8...1600 A up to 690V AC, 50/60 Hz. Depending upon the controller type ordered, the control power input can range from 100...240V AC or 24V AC/DC. Verify voltage on the product before you apply power.

Starting Modes

The SMC Flex Smart Motor Controller provides the following starting modes of operation as standard:

Starting Modes	
Soft Start	Pump Control Mode
Linear Speed Acceleration	Dual Ramp Start
Current Limit Start	Full-voltage Start
Selectable Kickstart	Preset Slow Speed

Soft Start

Soft Start limits the current throughout the soft start, and covers the largest number of general applications. The motor is given an initial torque setting. From the initial torque level, the output voltage to the motor is steplessly increased (ramped) during the acceleration ramp time. Initial torque setting and acceleration ramp time are user adjustable.



A motor's torque curve is not a linear function and depends on both applied voltage and current. If the soft starter ramped voltage that is applied to the motor is sufficient for it to develop enough torque to overcome the inertia of the load, the motor could quickly accelerate to full speed in less than the configured ramp time when using the Soft Start mode.

Figure 1 - Soft Start Timing Diagram

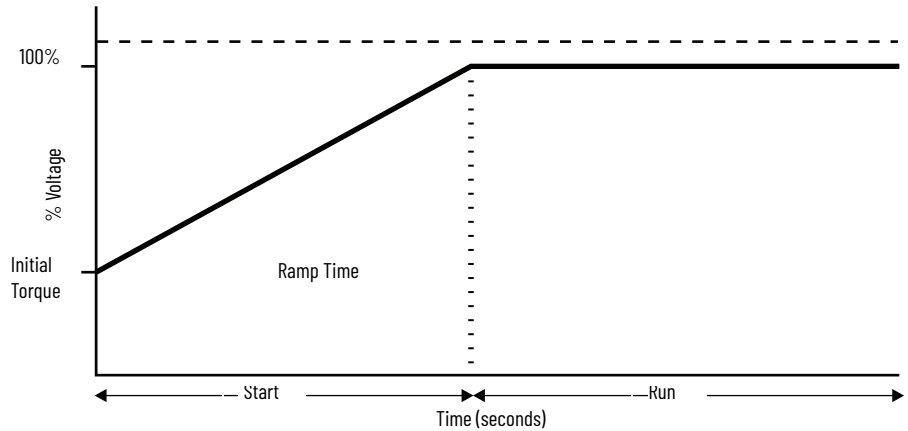

Linear Speed Acceleration

With this type of starting mode, the motor acceleration is at a constant rate. The controller accelerates the motor in a linear fashion from the off (0 speed) condition to full speed condition in the time configured in the user-defined ramp time (0...30 seconds). Kickstart is available with this option.

A tachometer input (0...5V DC) is required to perform this start mode.

Linear Speed Acceleration presents the least amount of stress on mechanical components. An initial torque value is configured to define a motor starting value.

Figure 2 - Linear Speed Acceleration Timing Diagram

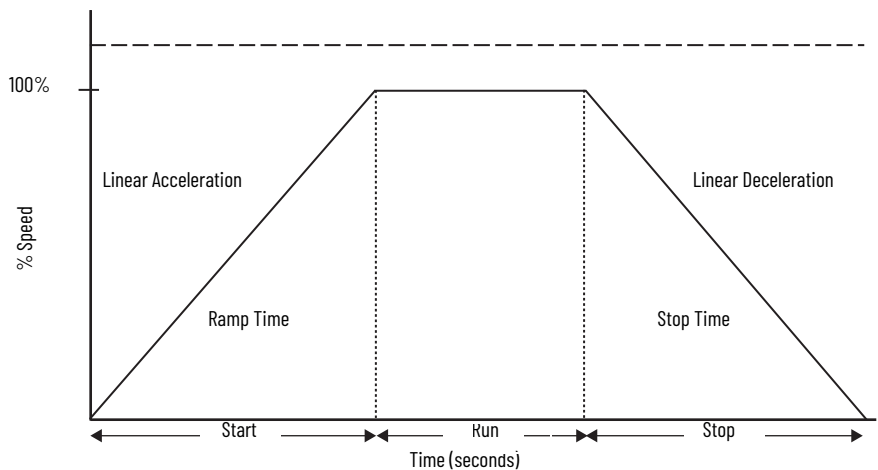

Current Limit Start

Current Limit Start provides a current limit-controlled start by maintaining a constant current to the motor. Use this method when it is necessary to limit the maximum starting current. You can adjust the starting current and current limit starting ramp time.

Figure 3 - Current Limit Start Timing Diagram

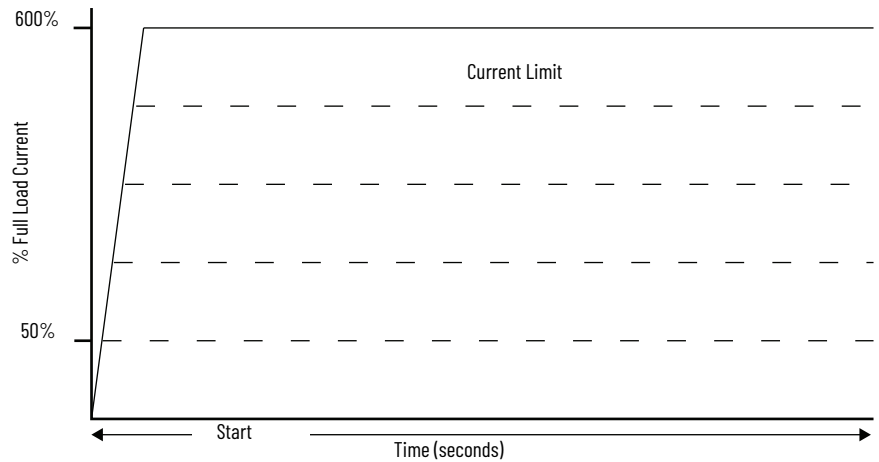

Selectable Kickstart

The kickstart feature provides a boost at startup to break away loads that can require a pulse of current/torque to get started. It is intended to provide a current/voltage pulse for a short time. Kickstart is available in Soft Start, Current Limit, Linear Speed Acceleration, and Pump Control modes.

Figure 4 - Selectable Kickstart Timing Diagram

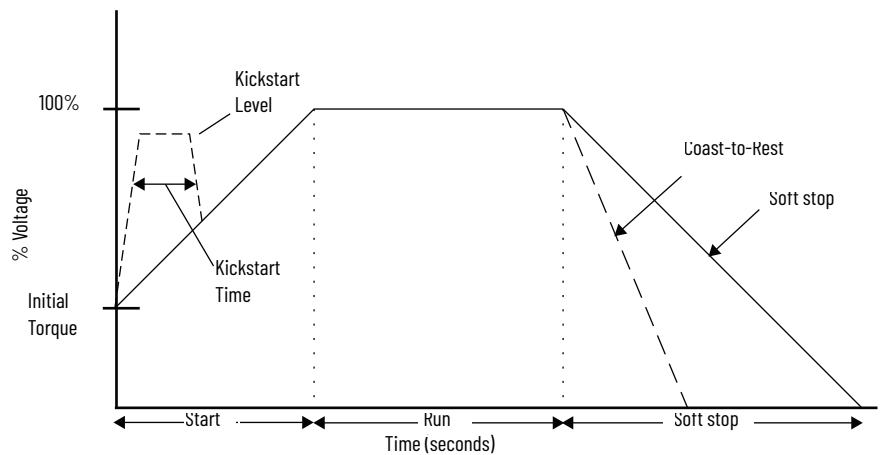

Pump Control Mode

Use Pump Control Mode to reduce surges in a fluid piping system and the resulting fluid hammer or check valve slam that is caused by starting or stopping a centrifugal pump at full voltage and full speed. This mode increases pump life by reducing pump cavitations. To provide these benefits, the microprocessor of the SMC Flex controller generates a motor start curve that follows the starting characteristics of a centrifugal pump and monitors operation during start to deliver reliable pump starts.

Figure 5 - Pump Control Mode Timing Diagram

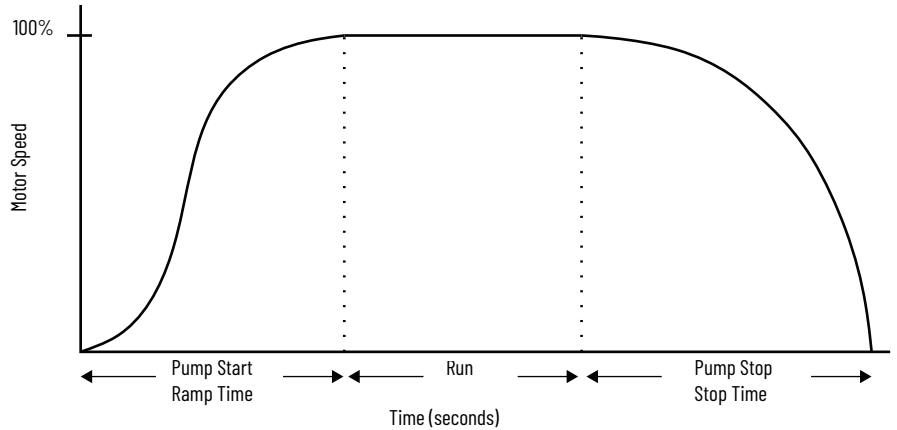

Dual Ramp Start

Dual Ramp Start is useful on applications with variable loads, starting torque, and start time requirements. Dual Ramp Start gives you the ability to select between two separate start profiles via any programmable auxiliary input. Each start profile can use any of the available starting modes.

Figure 6 - Dual Ramp Start Timing Diagram

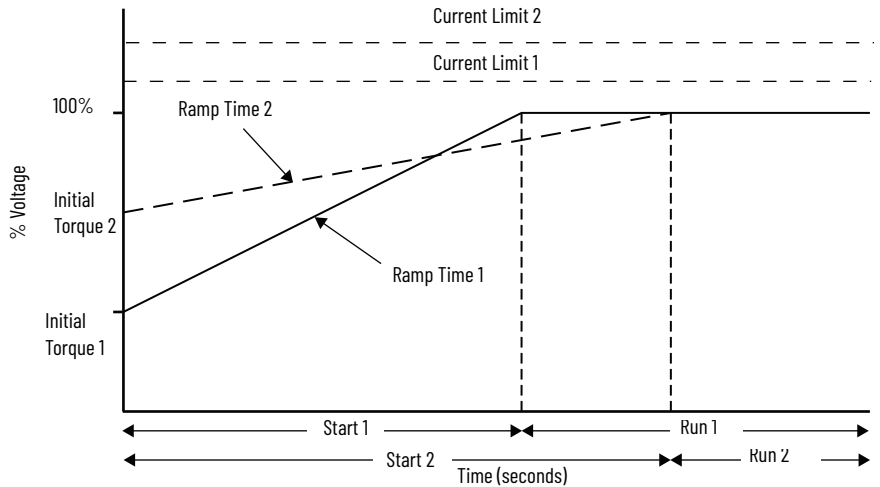

Full-voltage Start

Full-voltage Start is used in applications that require across-the-line starting. The SMC Flex controller performs like a solid-state across-the-line contactor. Full inrush current and locked-rotor torque are realized. You can program the SMC Flex controller to provide a full-voltage start in which the output voltage to the motor reaches full voltage in 250 ms.

Figure 7 - Full-voltage Start Timing Diagram

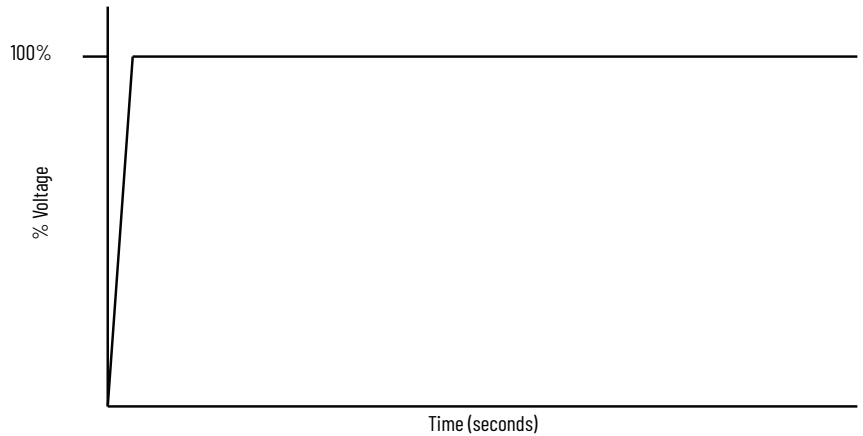

Preset Slow Speed

Use Preset Slow Speed on applications that require slow speed moves for positioning material. You can set the Preset Slow Speed at either 7% (low) or 15% (high) in the forward direction. You can program reverse speed and 10% (low) or 20% (high) of the base speed setting. No reversing contacts are required. To help achieve more-accurate stops, braking is also a part of this function. You can program two independent preset slow speed parameters for both speed and direction.

Figure 8 - Preset Slow Speed Timing Diagram

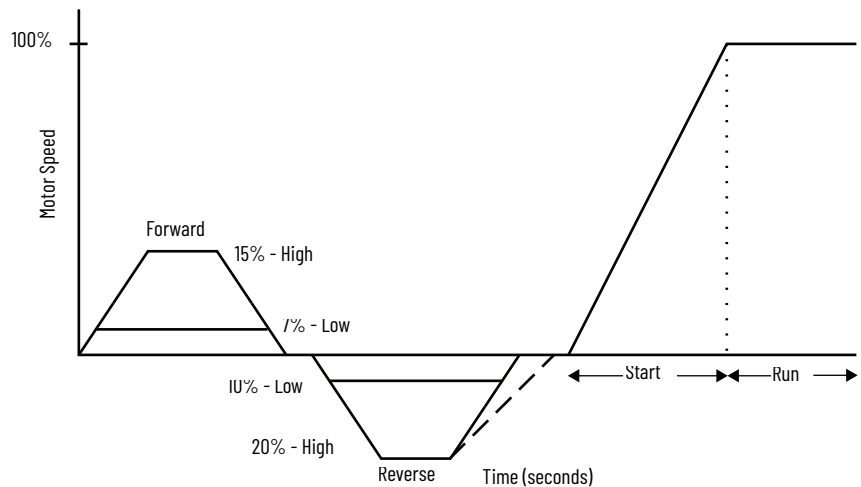

Stopping Modes

The SMC Flex Smart Motor Controller provides the following Stopping Modes of operation as standard:

Stopping Modes	
Coast	Linear Speed Deceleration
Soft stop	Pump Stop

Coast

Configure the stop mode to Coast sets the controller to perform a motor coast-to-stop maneuver.

Figure 9 - Coast-to-stop Timing Diagram

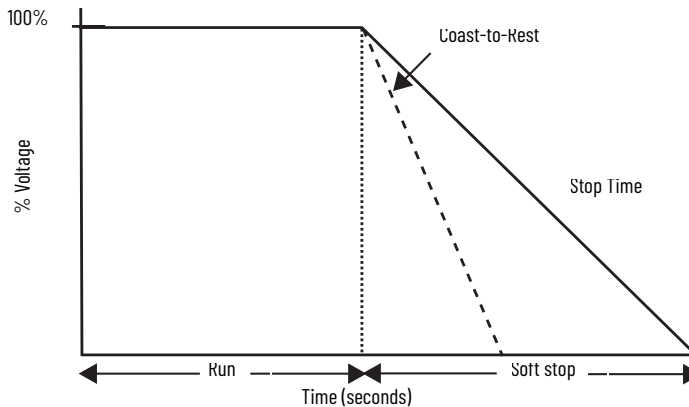

Soft Stop^(a)

The soft stop mode can be used in applications that require an extended stop time. You can adjust the voltage ramp down time from 0...120 seconds. The load stops when the programmed stop time has elapsed or the voltage ramp drops to a point where the load torque is greater than the motor torque.

Figure 10 - Soft Stop Timing Diagram

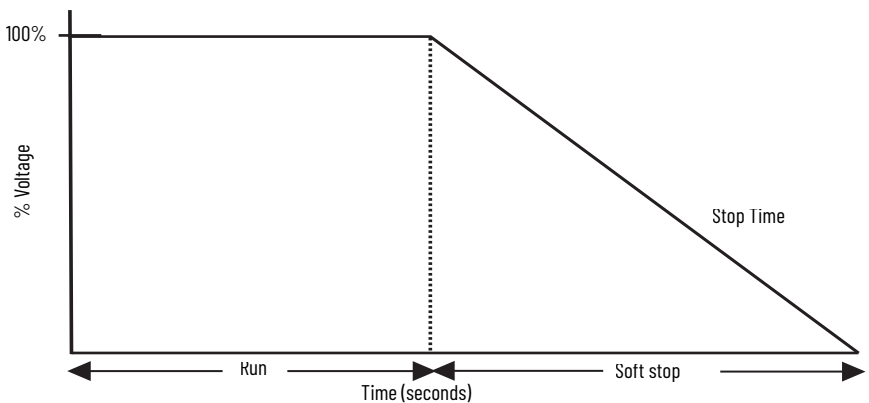

Linear Speed Deceleration^(a)

Configuring the motor stop mode to Linear Speed Deceleration mode commands the motor to stop from full speed to zero speed following a linear ramp based on the user-configured stop time. This stopping mode requires a tachometer input (0...5V DC).

You do not need to set up Linear Stop even if you have programmed a linear start. The Linear Stop cannot brake the motor/load and reduce the stopping time.

(a) Not intended to be used as an emergency stop. Consult the applicable standards for emergency stop requirements.

Figure 11 - Linear Speed Deceleration Timing Diagram

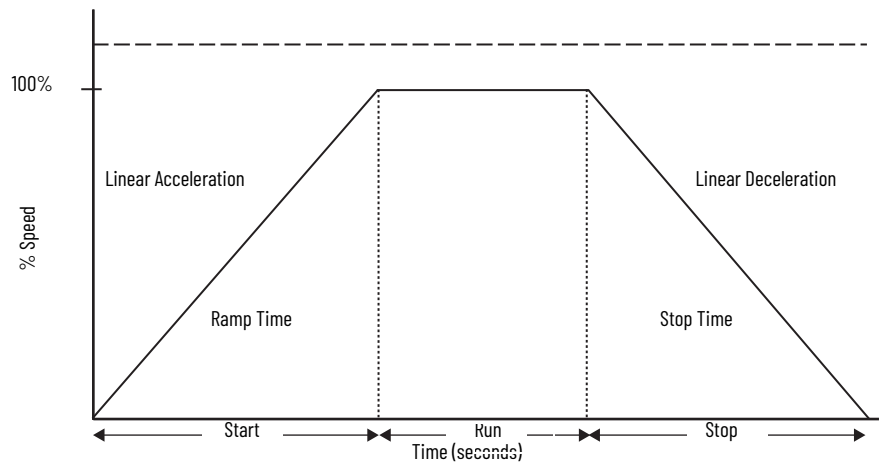

Pump Stop^(a)

Just as starting a centrifugal pump at full voltage causes fluid hammer and check valve slam, stopping a centrifugal pump that is running at full speed can also produce the same results. The Pump Stop mode of the SMC Flex generates a motor stop curve, which follows the stop characteristics of a centrifugal pump. The motor stop curve results in the gradual decrease in motor speed.

IMPORTANT Pump stopping can cause motor heating, depending on the mechanical dynamics of the pumping system. Select the lowest stopping time setting that satisfactorily stops the pump.

Figure 12 - Pump Stop Timing Diagram

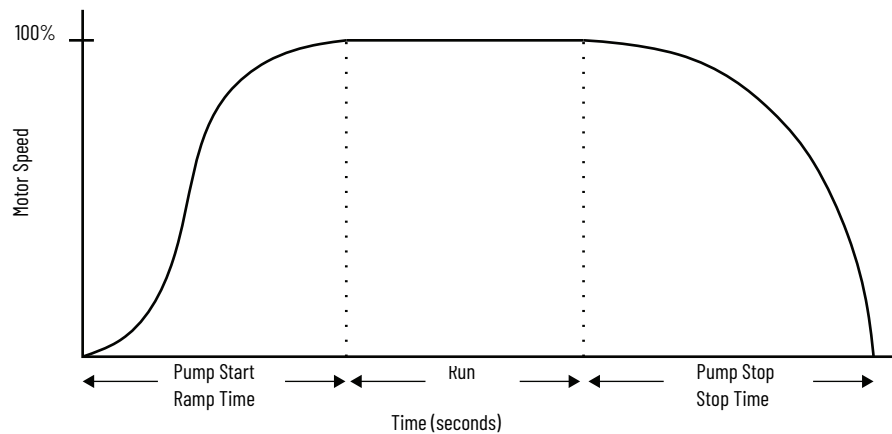

Braking Control Modes^(a)

The SMC Flex Smart Motor Controller provides the following braking control modes of operation as standard:

Braking Control Modes		
SMB—Smart Motor Braking	Accu-Stop	Slow Speed with Braking

Smart Motor Braking (SMB)^(a)

SMB provides motor braking for applications that require the motor to stop faster than a coast-to-rest. Braking control with automatic zero speed shutoff is fully integrated into the design of the SMC Flex controller. This design facilitates a clean, straight-forward installation and eliminates the requirement for additional hardware (for example, braking contactors, resistors, timers, and speed sensors). The micro-processor based braking system applies braking current to a standard squirrel-cage induction motor. The strength of the braking current is programmable from 0...400% of full-load current.

Figure 13 - SMB Timing Diagram

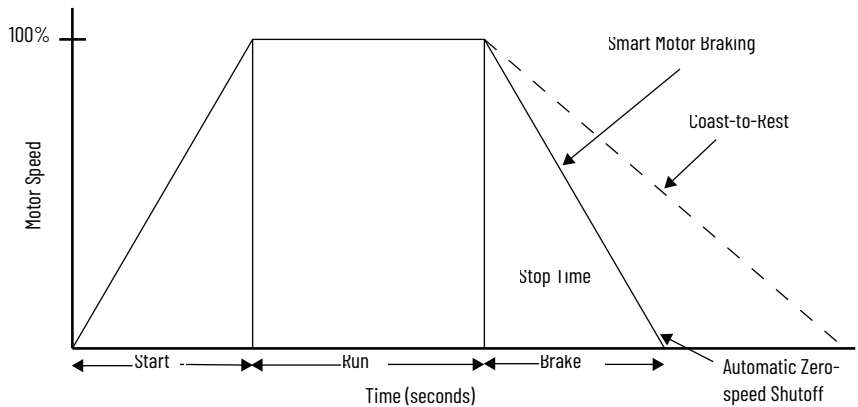

Slow Speed with Braking^(b)

Slow Speed with Braking is used on applications that require slow speed (in the forward or reverse direction) for positioning or alignment and also require braking control to stop. Preset Slow Speed provides either 7% of base speed (low) or 15% of base speed (high) settings in the forward direction. Braking current is adjustable from 0...400%.

Figure 14 - Slow Speed with Braking Timing Diagram

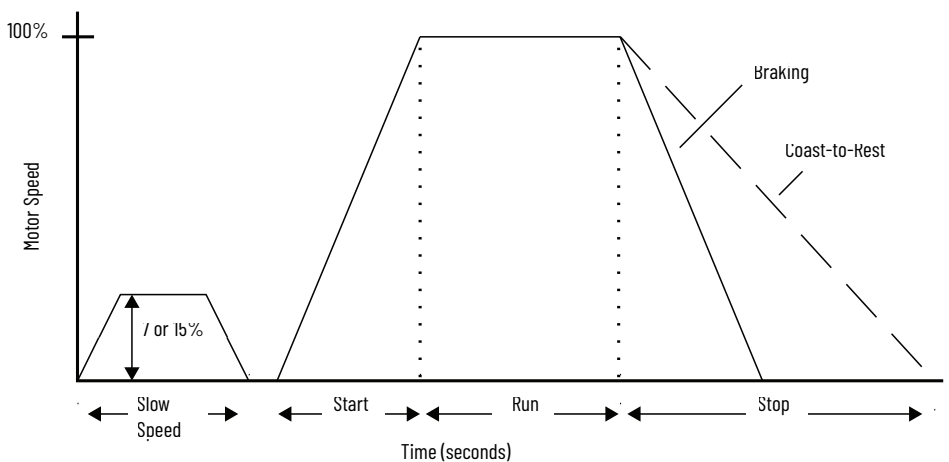

(a) Not intended to be used as an emergency stop. Consult the applicable standards for emergency stop requirements.

(b) Not intended to be used as an emergency stop. Consult the applicable standards for emergency stop requirements.

Accu-Stop^(b)

Use Accu-Stop in applications that require controlled position stopping. During stopping, braking torque is applied to the motor until it reaches the configured preset slow speed value (7% or 15%) and holds the motor at this speed until a stop command is given. Braking torque is then applied until the motor reaches zero speed. Braking current is programmable from 0...400% of full-load current.

Figure 15 - Accu-Stop Timing Diagram

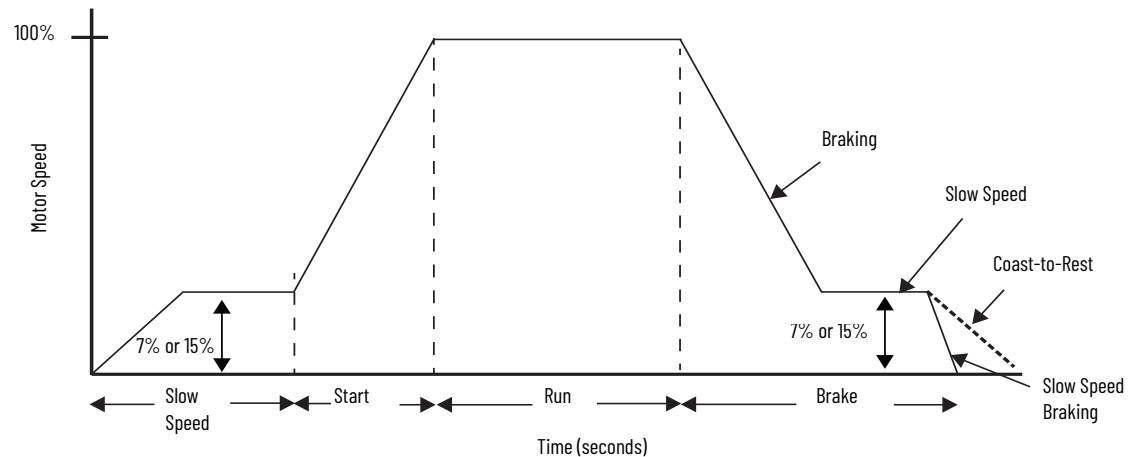

Protection and Diagnostics

This section describes the protection and diagnostic features that the SMC Flex controller provides.

Overload

The SMC Flex controller meets applicable requirements as a motor overload protective device. Thermal memory provides added protection and is maintained even when control power is removed. The built-in overload controls the value that is stored in Parameter 12, Motor Thermal Usage; an Overload Fault occurs when this value reaches 100%. The programming parameters in this section provide application flexibility and easy setup.

Parameter No.	Parameter	Range
44	Overload Class	Off, 10, 15, 20, 30
47	Overload Reset	Manual - Auto
46	Motor FLC	1.0...2200 A
45	Service Factor	0.01...1.99

The trip rating is 117% of the programmed FLC. [Figure 16](#) and [Figure 17](#) provide the overload trip curves for the available trip classes.

Underload^(a)

Utilizing the underload protection of the SMC Flex controller, motor operation can be halted if a sudden drop in current is sensed.

The SMC Flex controller provides an adjustable underload trip setting from 0...99% of the programmed motor full-load current rating. You can adjust the Trip delay time from 0...99 seconds.

(a) Underload protection is disabled during slow speed and braking operations.

Figure 16 - Overload Trip Curves

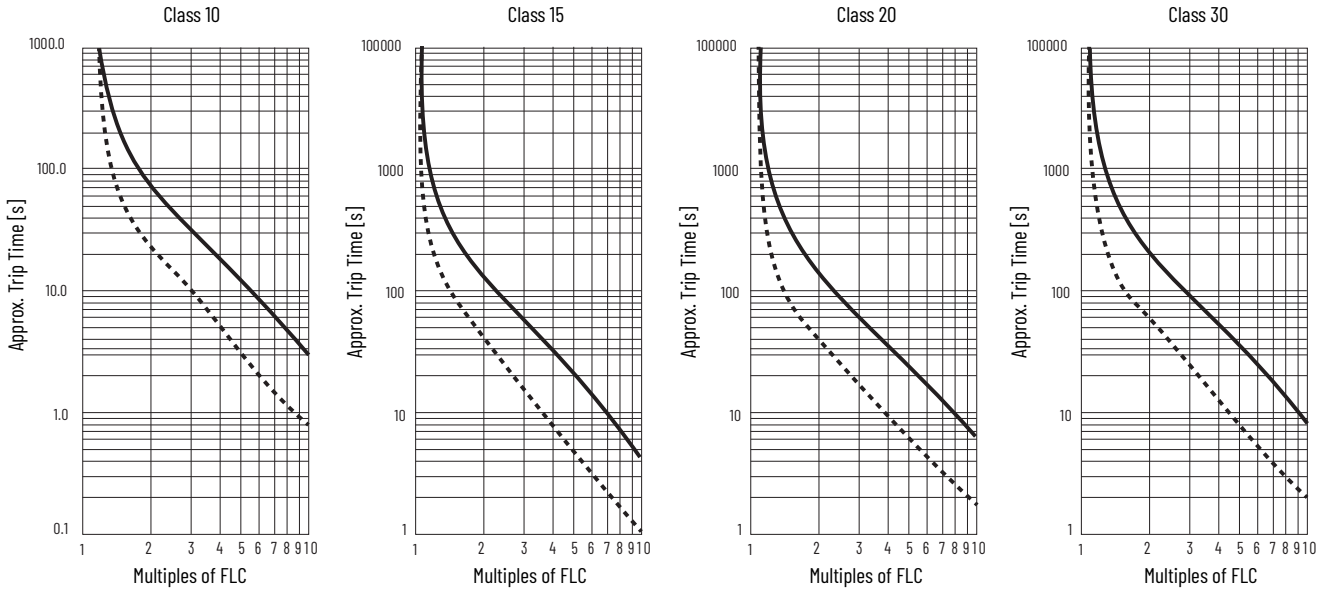

Graph Line	Description
—————	Approximate trip time for 3-phase balanced condition from COLD start
- - - - -	Approximate trip time for 3-phase balanced condition from HOT start

Figure 17 - Restart Trip Curves after Auto Reset

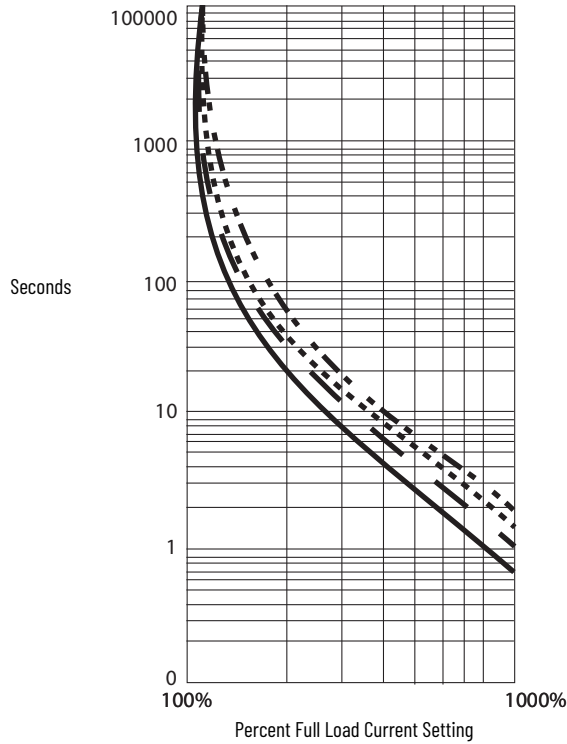

Graph Line	Trip Class	Auto Reset Time [s]
—————	10	90
—————	15	135
- - - - -	20	180
- - - - -	30	270

Undervoltage^(a)

You can halt motor operation if a sudden drop in voltage is detected by utilizing the undervoltage protection of the SMC Flex controller.

The SMC Flex controller provides an adjustable undervoltage trip setting from 0...99% of the programmed motor voltage. You can adjust the trip delay time from 0...99 seconds.

You can program an alarm (pre-fault) indication level to indicate when the unit is getting close to faulting. The alarm modification information is displayed through the LCD, HIM, Communication (if applicable) and alarm contact closing.

Overvoltage^(a)

You can halt motor operation if a sudden increase in voltage is detected by utilizing the overvoltage protection of the SMC Flex controller.

The SMC Flex controller provides an adjustable overvoltage trip setting from 0...199% of the programmed motor voltage. Trip delay time can be adjusted from 0...99 seconds.

You can program an alarm (pre-fault) indication level to indicate when the unit is getting close to faulting. The alarm modification information is displayed through the LCD, HIM, Communication (if applicable) and alarm contact closing.

Unbalance^(a)

The SMC Flex controller can detect an unbalance in line voltages. You can halt motor operation if the unbalance is greater than the desired range.

The SMC Flex controller provides an adjustable unbalance setting from 0...25% of the line voltages. Trip delay time can be adjusted from 0...99 seconds.

You can program an alarm (pre-fault) indication level to indicate that the unit is getting close to faulting. The alarm modification information is displayed through the LCD, HIM, Communication (if applicable) and alarm contact closing.

Stall Protection and Jam Detection

Motors can experience locked-rotor currents and develop high torque levels if a stall or a jam occurs. These conditions can result in breakdown of the winding insulation or mechanical damage to the connected load. The SMC Flex controller provides both stall protection and jam detection for enhanced motor and system protection. A jam level (as a percent of motor FLC) is configurable for both an alarm and motor shutdown (fault). In addition, both stall and jam conditions let you set a delay time before initiating an alarm (jam only) or motor shutdown (fault).

Stall protection is user adjustable from 0.0...10.0 seconds (in addition to the ramp time programmed).

(a) Undervoltage, overvoltage, and voltage unbalance protection are disabled during braking operation.

Figure 18 - Stall Protection

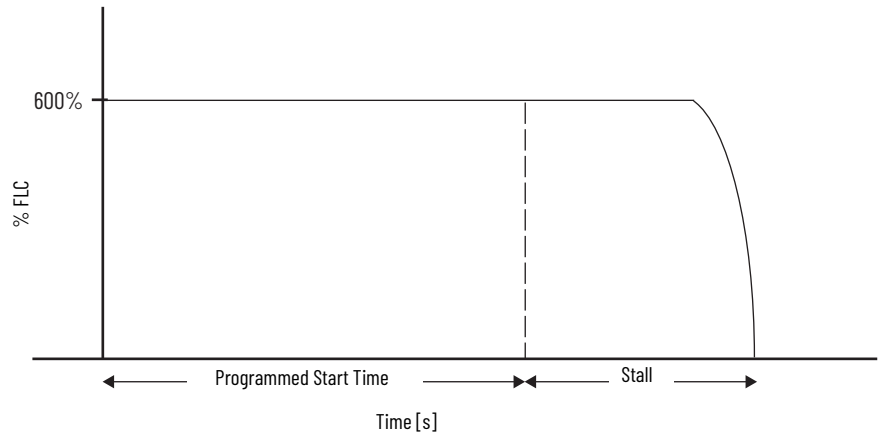

Jam detection lets you determine the jam level (up to 1000% of the motor's FLC rating) and the delay time (up to 99.0 seconds) for application flexibility.

Figure 19 - Jam Detection (a) (b)

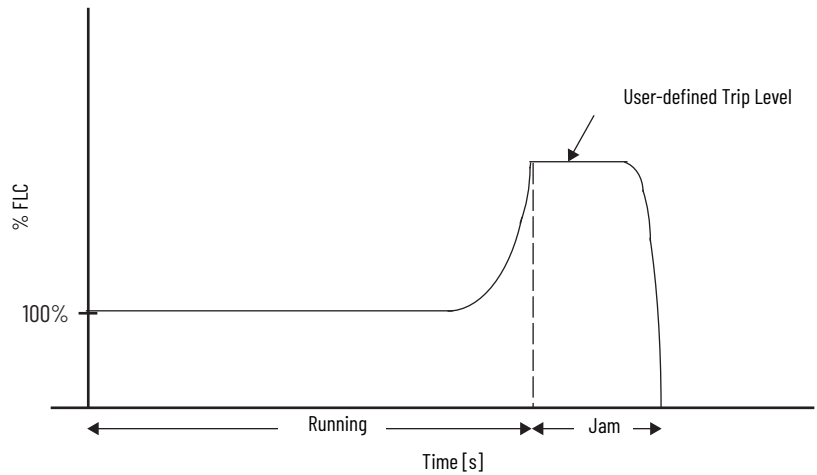

You can program an alarm (pre-fault) indication level to indicate when the unit is getting close to faulting. The alarm modification information is displayed through the LCD, HIM, Communication (if applicable) and alarm contact closing.

(b) Unit self-protects in a jam condition.

(a) Jam detection is disabled during slow speed and braking operation.

Ground Fault Trip

The SMC Flex controller trips with a ground fault (GF) indication if:

- No other fault currently exists
- Ground fault protection is enabled
- GF Inhibit Time (Parameter 75) has expired
- GF Current is equal to or greater than the GF Trip Level (Parameter 73) for a time period greater than the GF Trip Delay (Parameter 74)

Table 2 - Ground Fault Trip Parameters

Parameter No.	Parameter Name	Description	Adjustment Range
73	Gnd Flt Level	Defines the ground fault current at which the SMC Flex controller trips	1.0...5.0 A or 5.0...25 A
74	Gnd Flt Delay	Defines the time period a ground fault condition must be present before a trip occurs	0.1...250 s
75	Gnd Flt Inh Time	Inhibits a ground fault trip from occurring during the motor starting sequence	0...250 s

IMPORTANT The ground fault inhibit timer starts after the maximum phase of load current transitions from 0 A to 30% of the device's minimum FLA Setting or the GF Current is greater than or equal to 0.5 A. The SMC Flex controller does not begin monitoring for a ground fault condition until the Gnd Flt Inh Time expires.

Ground Fault Alarm

The SMC Flex controller indicates a Ground Fault Alarm if:

- No warning currently exists
- Ground fault alarm is enabled
- GF Inhibit Time (Parameter 75) has expired
- GF Current is equal to or greater than the Gnd Flt A Lvl (Parameter 77)

Table 3 - Ground Fault Alarm Parameters

Parameter No.	Parameter Name	Description	Adjustment Range
77	Gnd Flt A Lvl	Defines the ground fault current at which the SMC Flex controller indicates a warning	1.0...5.0 A or 5.0...25 A
78	Gnd Flt A Dly	Defines the time period a ground fault alarm condition must be present before a trip occurs	0...250 s

Thermistor/PTC Protection

The SMC Flex controller provides terminals 23 and 24 for the connection of positive temperature coefficient (PTC) thermistor sensors. PTC sensors are commonly embedded in motor stator windings to monitor the motor winding temperature. When the motor winding temperature reaches the PTC sensor's temperature rating, the PTC sensor's resistance transitions from a low to high value. Because PTC sensors react to actual temperature, enhanced motor protection can be provided to address such conditions as obstructed cooling and high ambient temperatures.

[Table 4](#) defines the SMC Flex PTC thermistor input and response ratings:

Table 4 - PTC Input Ratings

Description	Value
Response resistance	3400 Ω \pm 150 Ω
Reset resistance	1600 Ω \pm 100 Ω
Short-circuit Trip Resistance	25 Ω \pm 10 Ω

Table 4 - PTC Input Ratings

Description	Value
Maximum Voltage at PTC Terminals (RPTC = 4 kW)	<7.5V
Maximum Voltage at PTC Terminals (RPTC = open)	30V
Maximum Number of Sensors	6
Maximum Cold Resistance of PTC Sensor Chain	1500 Ω
Response Time	800 ms

[Figure 21](#) illustrates the required PTC sensor characteristics that are specified in IEC-34-11-2.

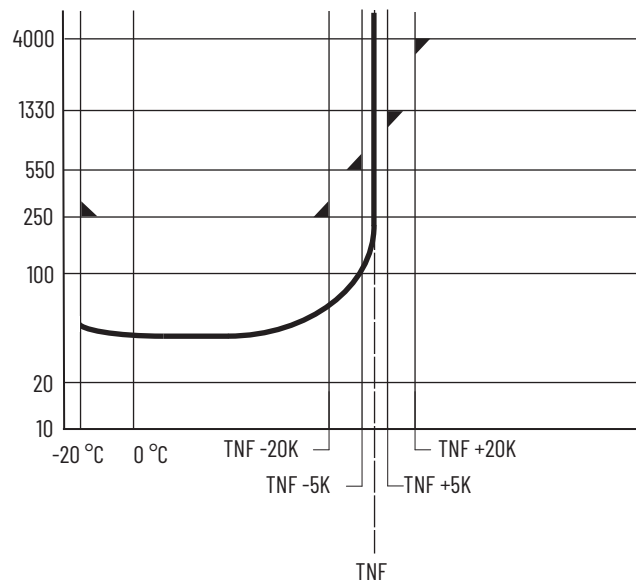
Figure 21 - PTC Sensor Characteristics per IEC-34-11-2

PTC Trip

The SMC Flex controller trips with a PTC indication if:

- No other fault currently exists
- PTC protection is enabled

The resistance across terminals 23 and 24 is either greater than the relay's response resistance or less than the short-circuit trip resistance.

Excessive Starts/Hour

The SMC Flex controller lets you program the allowed number of starts per hour (up to 99). This helps minimize motor stress caused by repeated starting over a short time period.

Overtemperature

The SMC Flex controller uses the value in Parameter 119 to monitor the temperature of the SCRs and Bypass by using internal thermistors. When the maximum rated temperature of the power poles is reached, the unit shuts down and restart is inhibited.

An overtemperature condition can indicate inadequate ventilation, high ambient temperature, overloading, or excessive cycling. After the temperature is reduced to allowable levels, the fault can be cleared.

Open Gate

An open gate fault indicates that improper SCR firing, typically caused by an open SCR gate, has been detected on one of the power poles. Before the controller shuts down, it attempts to start the motor a total of three times.

Line Faults

The SMC Flex controller continually monitors line conditions for abnormal factors. Pre-start protection includes:

- Line Fault (with phase indication)
 - Line voltage loss
 - Missing load connection
 - Shorted SCR

Running protection includes:

- Line Fault (no phase indication)
 - Line voltage loss
 - Missing load connection

You can toggle Phase Reversal protection either On or Off. Phase Reversal protection is functional only at pre-start.

Metering

Power monitoring parameters include:

- Three-phase current (Parameters 4, 5, and 6)
- Three-phase voltage (Parameters 1, 2, and 3)
- Power in kW (Parameter 7)
- Power usage in kWh (Parameter 8)
- Power factor (Parameter 11)
- Motor thermal capacity usage (Parameter 12)
- Elapsed time (Parameter 9)

Voltage measurement is not available during the braking operation of the Smart Motor Braking, Accu-Stop, and Slow Speed with Braking control options.

The elapsed time and kWh values are automatically saved to memory on power down.

Motor thermal capacity usage is determined by the built-in electronic thermal overload. An overload fault occurs when this value reaches 100%.

I/O

The SMC Flex controller can accept up to two inputs and four outputs that are controlled over a network. The two inputs are controlled at terminal 16 (Option Input #1, Parameter 132), and terminal 15 (Option Input #2, Parameter 29). For these two inputs, see [Table 26](#) for the parameter settings and [Table 39](#) and [Table 40](#) for the bit identification.

You can program the Stop Input to meet the desired stop functionality by using these two terminals as inputs.

The four outputs are Aux #1 (Parameter 107), Aux #2 (Parameter 110), Aux #3 (Parameter 108), and Aux #4 (Parameter 109). All auxiliary contacts are programmable to the function found in [Table 26](#). If the outputs are programmed to Network or Network NC, they can be controlled over a Network. See [Table 40](#), which defines the Logic Command Word (Control).

Communication

A serial interface port (DPI) is provided as standard, which lets you connect the SMC Flex controller connection to the Bulletin 20-HIM LCD interface modules.

Figure 22 - DPI Location

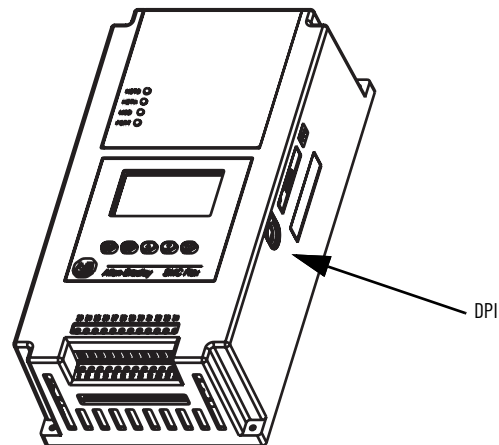

You can connect two peripheral devices to the DPI. The maximum output current through the DPI is 280 mA.

Programming

Setup is easy with the built-in keypad and three-line, 16 character backlit LCD. Parameters are organized in a three-level menu structure that uses a text format for straightforward programming.

Figure 23 - Built-in Keypad and LCD

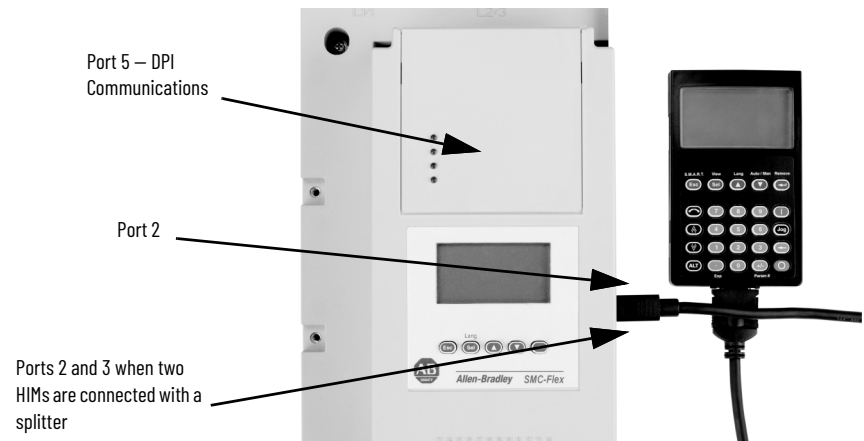

Status Indication

- Four programmable hard contact outputs are provided as standard. All auxiliary contacts are programmable for the following states:
- Normal (selectable N.O./N.C.)
- Up-to-Speed (selectable N.O./N.C.)
- Alarm (selectable N.O./N.C.)
- Fault (selectable N.O./N.C.)
- Network Control (selectable N.O./N.C.)
- External Bypass (N.O. only)

Figure 24 - Control Terminals

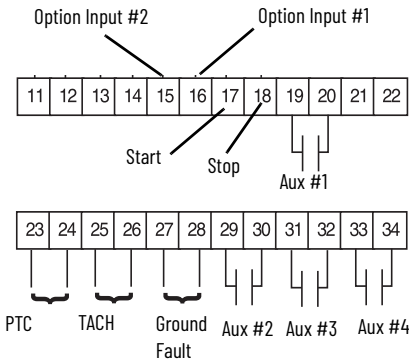

Network inputs can be obtained via proper programming of Option Input #1 (Parameter 132) and Option Input #2 (Parameter 24).

Installation

This chapter explains how to receive, unpack, and set up the SMC™ Flex controller.

Receive the Controller

It is your responsibility to thoroughly inspect the equipment before accepting the shipment from the freight company. Check the item(s) received against the purchase order. If any items are damaged, it is your responsibility not to accept delivery until the freight agent has noted the damage on the freight bill. Should any concealed damage be found during unpacking, it is again your responsibility to notify the freight agent. The shipping container must be left intact and the freight agent should be requested to make a visual inspection of the equipment.

Unpack the Controller

Remove all packing material, wedges, or braces from within and around the controller.

Inspect the Controller

After you unpack the controller, check the item(s) nameplate catalog number against the purchase order.

Storage

Keep the controller in its shipping container prior to installation. If the equipment is not to be used for an extended period, you must store it according to the following instructions in order to maintain warranty coverage.

- Store in a clean, dry location.
- Maintain an ambient temperature range of -20... +75 °C (-4...+167 °F).
- Store within a relative humidity range of 0% to 95%, noncondensing.
- Do not store equipment where it could be exposed to a corrosive atmosphere.
- Do not store equipment in a construction area.

Lifting

For controllers rated 625...1250 A, the device should only be lifted from designated lifting points. The lifting points are designed to accept a 1/2...13 threaded hoist ring capable of lifting 2500 pounds. [Figure 26](#) shows the lifting points.

Figure 25 - Lifting Caution Label

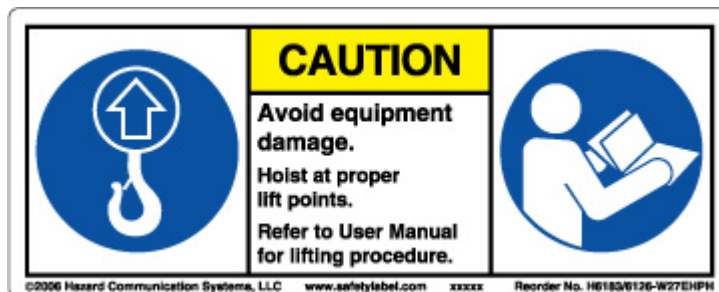
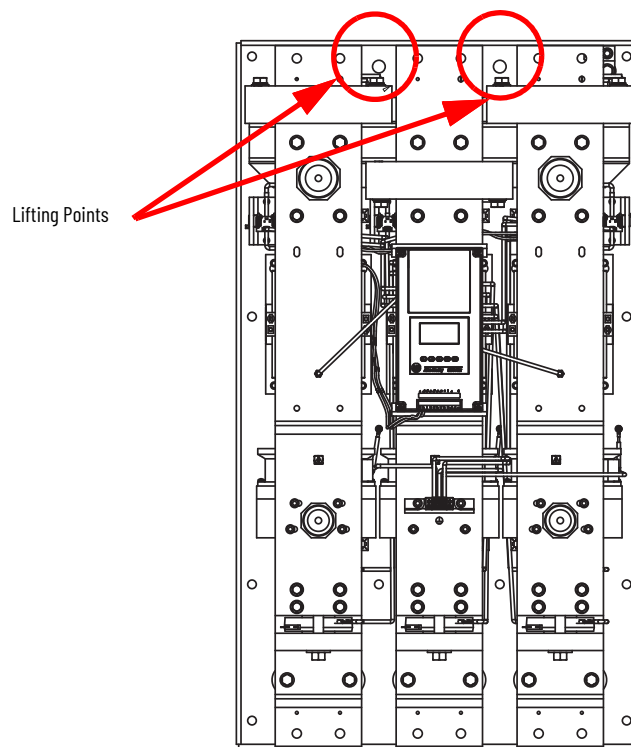

Figure 26 - Lifting Points



General Precautions

In addition to the precautions listed throughout this manual, you must read and understand the following statements, which are general to the system.



ATTENTION: The controller contains ESD- (electrostatic discharge) sensitive parts and assemblies. Static control precautions are required when installing, testing, servicing, or repairing the assembly. Component damage may result if ESD control procedures are not followed. If you are not familiar with static control procedures, refer to applicable ESD protection handbooks.



ATTENTION: An incorrectly applied or installed controller can damage components or reduce product life. Wiring or application errors, such as undersizing the motor, incorrect or inadequate AC supply, or excessive ambient temperatures, may result in malfunction of the system.



ATTENTION: Only personnel familiar with the controller and associated machinery should plan or implement the installation, start-up, and subsequent maintenance of the system. Failure to do this may result in personal injury and/or equipment damage.



ATTENTION: Hazardous voltages that can cause shock, burn, or death are present on L1, L2, L3, T1, T2, T3, T4, T5, and T6.
ATTENTION: Power terminal covers can be installed to prevent inadvertent contact with terminals. Disconnect the main power before servicing the motor controller or associated wiring.

Degree of Protection

The SMC Flex soft starters have an IP00 or IP2X protection rating, depending on the size. You must install the device in IP54 (Type 2) switchgear cabinets, taking into account the ambient conditions. Make sure that no dust, liquids, or conductive parts can enter the soft starter. Soft starter operation produces waste heat (heat loss). See [Table 5](#) or the SMC-3™, SMC Flex, and SMC-50™ Smart Motor Controllers Technical Data, publication [150-TD009](#).

Heat Dissipation

[Table 5](#) provides the maximum heat dissipation at rated current for the controllers. Heat dissipation is reduced for currents that are lower than rated value.

Table 5 - Maximum Heat Dissipation

SMC Rating [A]	5	25	43	60	85	108	135	201	251	317	361	480	625	700	970	1250
Max. Watts	70	70	81	97	129	91	104	180	198	225	245	290	446	590	812	1222

Enclosures

The open-style design of the SMC Flex controller requires that it be installed in an enclosure. **The internal temperature of the enclosure must be kept within the range of 0...50°C.**

For Type 12 (IP54) enclosures, the guidelines that are shown in [Table 6](#) are recommended to limit the maximum controller ambient temperature.

There should be a clearance of at least 15 cm (6 in.) above and below the controller. This area allows air to flow through the heatsink.

Table 6 - Minimum Enclosure Size

Controller Rating [A]	IP65 (Type 4/12) ⁽¹⁾		
	B Height	A Width	C Depth
Non-Combination Controller [mm (in.)]			
5	610 (24)	406 (16)	254 (10)
25	610 (24)	406 (16)	254 (10)
43	610 (24)	406 (16)	254 (10)
60	610 (24)	406 (16)	254 (10)
85	610 (24)	406 (16)	254 (10)
108	762 (30)	610 (24)	305 (12)
135	762 (30)	610 (24)	305 (12)
201	965 (38)	762 (30)	356 (14)
251	965 (38)	762 (30)	356 (14)
317	1295 (51)	914 (36)	356 (14)
361	1295 (51)	914 (36)	356 (14)
480	1295 (51)	914 (36)	356 (14)
625...780	2286 (90)	762 (30)	508 (20)
970...1250 ⁽²⁾	2286 (90)	762 (30)	508 (20)
Combination Controllers with Fusible Disconnect			
5	610 (24)	406 (16)	254 (10)
25	610 (24)	406 (16)	254 (10)
43	610 (24)	406 (16)	254 (10)
60	610 (24)	406 (16)	254 (10)
85	610 (24)	406 (16)	254 (10)
108	965 (38)	762 (30)	356 (14)
135	965 (38)	762 (30)	356 (14)
201	965 (38)	762 (30)	356 (14)
251	965 (38)	762 (30)	356 (14)
317	1524 (60)	965 (38)	356 (14)
361	1524 (60)	965 (38)	356 (14)
480 ⁽³⁾	1524 (60)	965 (38)	356 (14)
480 ⁽⁴⁾	2286 (90)	889 (35)	508 (20)
625...780	2286 (90)	1397 (55)	508 (20)
970...1250 ⁽²⁾	2286 (90)	1397 (55)	508 (20)
Combination Controllers with Circuit Breaker			
5	610 (24)	406 (16)	254 (10)
25	610 (24)	406 (16)	254 (10)
43	610 (24)	406 (16)	254 (10)

Table 6 - Minimum Enclosure Size (Continued)

Controller Rating [A]	IP65 (Type 4/12) ⁽¹⁾		
	B Height	A Width	C Depth
60	610 (24)	406 (16)	254 (10)
85	610 (24)	406 (16)	254 (10)
108	965 (38)	762 (30)	356 (14)
135	965 (38)	762 (30)	356 (14)
201	965 (38)	762 (30)	356 (14)
251	965 (38)	762 (30)	356 (14)
317	1295 (51)	914 (36)	356 (14)
361	1295 (51)	914 (36)	356 (14)
480	1295 (51)	914 (36)	356 (14)
625...780	2286 (90)	1397 (55)	508 (20)
970...1250 ⁽²⁾	2286 (90)	1397 (55)	508 (20)

- (1) Larger enclosure may be required based on options selected. Consult your local Rockwell Automation Sales office or Allen-Bradley distributor.
- (2) 970 and 1250 A SMC Flex controllers require a door-mounted fan that is capable of delivering 240 cfm. Appropriate inlet and outlet filtering is required.
- (3) Use this row for 460V -58 and 575V -59.
- (4) Use this row for 460V -59 and 575V -60 and -61

Mounting

All units are fan cooled. It is important to locate the controller in a position that allows air to flow vertically through the power module. **The controller must be mounted in a vertical plane and have a minimum of 15 cm (6 in.) free space above and below the controller.**

When drilling or installing near the soft starter, make sure that adequate measures are taken to protect the device from dust and debris. See [Figure 27](#).

Figure 27 - SMC Flex Mounting Protection

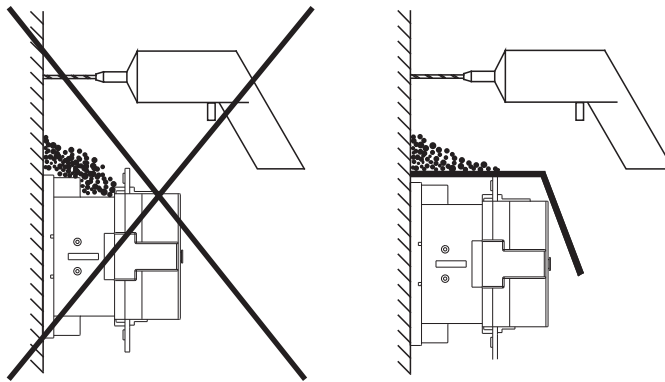

Power Factor Correction Capacitors

The controller can be installed on a system with power factor correction capacitors (PFCCs). The capacitors **must** be located on the line side of the controller. This must be done to prevent damage to the SCRs in the SMC Flex controller.

When it is discharged, a capacitor essentially has zero impedance. For switching, sufficient impedance should be connected in series with the capacitor bank to limit the inrush current. One method for limiting the surge current is to add inductance in the capacitor's conductors. This can be accomplished by creating turns or coils in the power connections to the capacitors.

- 250V – 15 cm (6 in.) diameter coil, 6 loops
- 480...690V – 15 cm (6 in.) diameter coil, 8 loops

Take care in mounting the coils so that they are not stacked directly on top of each other; stacking causes a canceling effect. Mount the coils on insulated supports away from metal parts so they will not act as induction heaters. If an isolation contactor is used, put capacitors in front of contactor.

For further instructions, consult the PFCC vendor.

Figure 28 - Typical Wiring Diagram for Power Factor Correction Capacitors

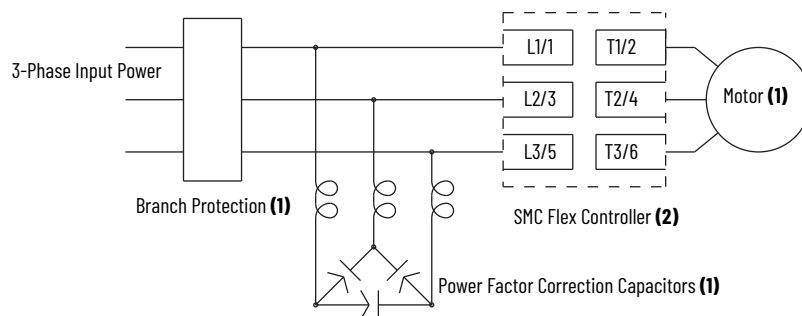

Note Number	Description
1	Customer supplied.
2	Overload protection is included as a standard feature of the SMC Flex controller.

Figure 29 - Typical Wiring Diagram for Power Factor Correction Capacitors and Contactor

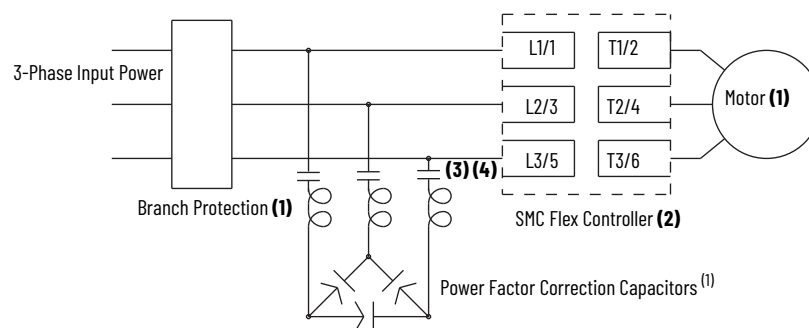

Note Number	Description
1	Customer supplied.
2	Overload protection is included as a standard feature of the SMC Flex controller.
3	Energize 1/2 second before start command to the SMC Flex controller. Alternate: Energize contactor after up-to-speed.
4	Open contactor after stopping method is complete. Alternate: Open contactor before initiating a stop.

Protective Modules

Protective modules containing metal oxide varistors (MOVs) can be installed on controllers rated 5...1250 A and 200...600V, to protect the power components from electrical transients. The protective modules clip voltage transients generated on the lines to prevent such surges from damaging the SCRs.



ATTENTION: When installing or inspecting the protective module, make sure that the controller has been disconnected from the power source. The protective module should be inspected periodically for damage or discoloration. Replace if necessary.

Motor Overload Protection

Thermal motor overload protection is provided as standard with the SMC Flex controller. If the overload trip class is less than the acceleration time of the motor, nuisance tripping may occur.



ATTENTION: Overload protection should be properly coordinated with the motor.

Two applications require special consideration: two-speed motors, and multi-motor protection.

Two-speed Motors

The SMC Flex controller has overload protection available for single speed motors. When the SMC Flex controller is applied to a two-speed motor, the Overload Class parameter must be programmed to OFF and separate overload relays must be provided for each speed.

Multi-motor Protection

If the SMC Flex controller is controlling more than one motor, individual overload protection is required for each motor.

Electromagnetic Compatibility (EMC)

The following guidelines are provided for EMC installation compliance.



ATTENTION: This product has been designed for Class A equipment. Use of the product in domestic environments may cause radio interference, in which case, the installer may need to employ additional mitigation methods.

Enclosure

Install the product in a grounded metal enclosure.

Wiring

Wire in an industrial control application can be divided into three groups: power, control, and signal. The following recommendations for physical separation between these groups is provided to reduce the coupling effect.

- Different wire groups should cross at 90° inside an enclosure.
- Minimum spacing between different wire groups in the same tray should be 16 cm (6 in.).
- Wire runs outside an enclosure should be run in conduit or have shielding/armor with equivalent attenuation.
- Different wire groups should be run in separate conduits.
- Minimum spacing between conduits containing different wire groups should be 8 cm (3 in.).
- For additional guidelines, please refer to Wiring and Grounding guidelines, publication [DRIVES-IN001](#).

Additional Requirements

- If linear acceleration is used, a separate conduit or wire way should be used for the tachometer leads.
- Wire earth ground to control terminal 14.
- Use shielded wire for PTC, Tachometer, and ground fault input.
- Terminate shielded wires to terminal 14.
- Ground fault CT must be inside or within 3 m of metal enclosure.

To meet product susceptibility requirements, ferrite cores need to be added to the communication lines. When using an external HIM (or DPI interface), a core should be added to the HIM cable near the SMC Flex control module. The recommended core is Fair-Rite no. 0431167281 or equivalent. When you are using a DeviceNet™ circuit, two cores need to be added to the DeviceNet cable near the SMC Flex control module. The recommended cores are TDK ZCAT2023 0930H and TDK ZCAT2035 0930 or equivalent. All cores specified are the split type cores and can be added to existing connections.

New EMC Compliance - Conducted Emissions

There are new requirements for conducted emissions per IEC 60947-4-2 $\leq 20\text{kVA}$ that require additional external components for SMC Flex units with 100...240V AC control power (code "D" in catalog string for control voltage) and rated 135A and below:

- Use Schaffner part number FN2090-3-06 external power line filter for the control power. Connect to SMC Flex controller terminals 11 and 12.
- Use Fair-Rite Products part number 2675102002 external ferrite core with 5 turns for the control power earth ground. Connect to SMC Flex controller terminal 14.
- Use Rockwell Automation Cat. No. 150-SMCAP capacitor module connected to the incoming 3-phase power (terminals L1, L2, L3). Note: This is an SMC-50 controller accessory that you can use with SMC Flex units for this purpose.

Figure 30 - Cat. No. 150-SMCAP Capacitor Module Wiring Configuration

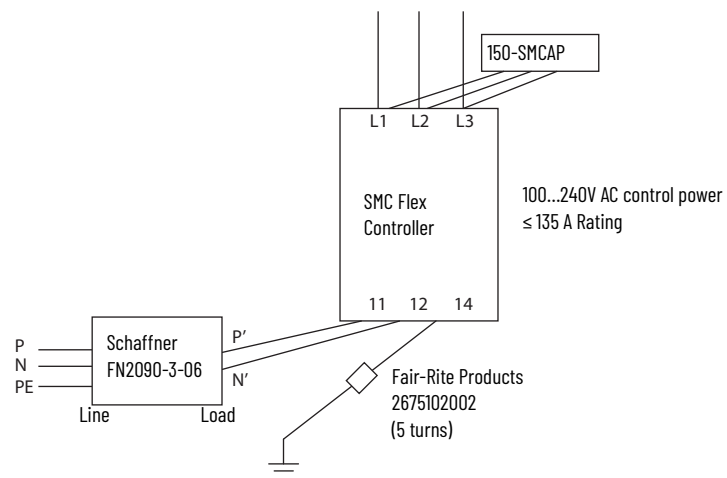

Notes:

Wiring

This chapter illustrates basic wiring configurations for the SMC™ Flex controller.

Wiring Terminal Locations

The SMC Flex controller wiring terminal locations are shown in [Figure 31](#) through [Figure 33](#). Incoming three-phase power connections are made to terminals L1/1, L2/3, and L3/5. Load connections to Line motors are made to T1/2, T2/4, and T3/6; load connections to Wye-Delta motors are made to T1/2, T2/4, T3/6, T4/8, T5/10, and T6/12.

Figure 31 - Wiring Terminal Locations—5...85 A Devices

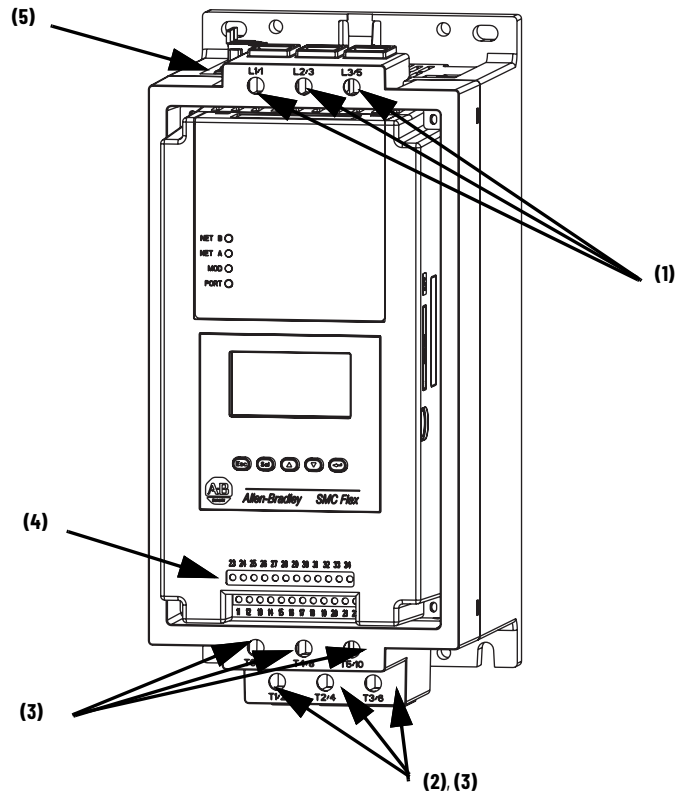

Note Number	Information
1	Incoming Line Termination
2	Line Motor Connections
3 ⁽¹⁾	Delta Motor Connections
4	Control Terminations
5	Fan Terminations

(1) IP20 protective covers on Delta termination must be removed when connecting in a Delta configuration.

Figure 32 - Wiring Terminal Locations—108...480 A Devices

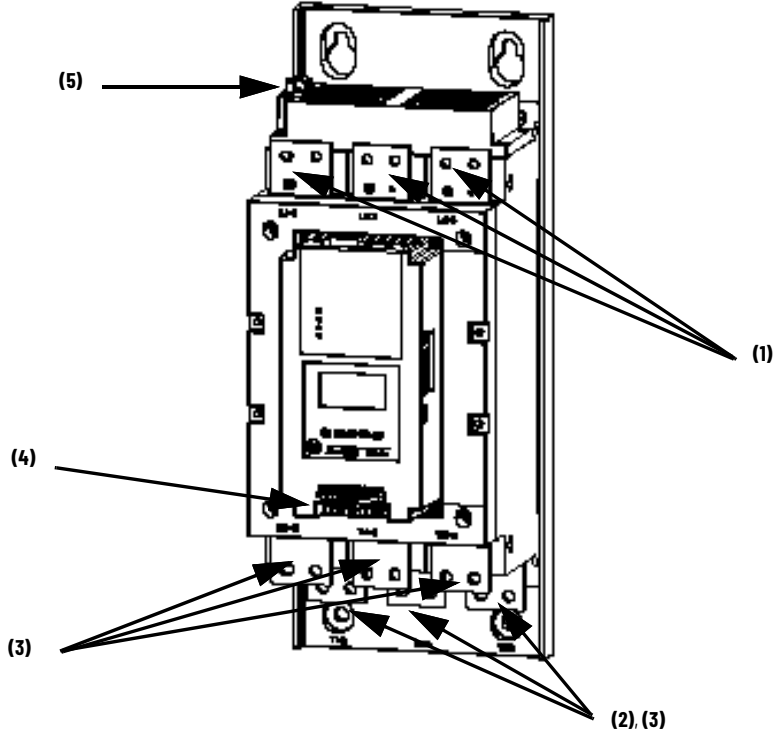

Note Number	Information
1	Incoming Line Termination
2	Line Motor Connections
3	Delta Motor Connections
4	Control Terminations
5	Fan Terminations

Figure 33 - Wiring Terminal Locations—625...1250 A Devices

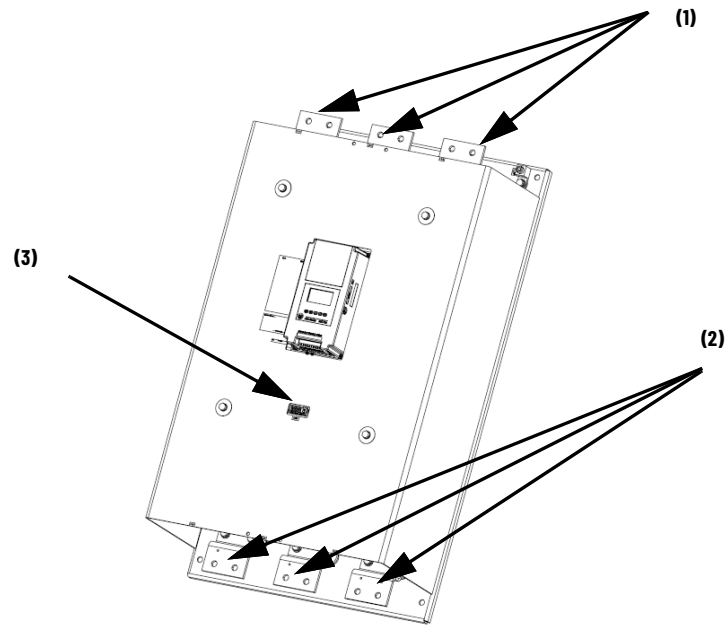

Note Number	Information
1	Incoming Line Termination
2	Line Motor Connections
3	Terminal Block CP1 - Common Control Power Connections (Fans, Contactors, and Control Modules)

Power Structure

The SMC Flex controller has an integrated mechanical run contactor on each phase of the motor to minimize heat generation during run time. These contacts are pulled in sequentially in the 108...1250 A units. In the 5...85 A units, these contacts are pulled simultaneously. The SMC Flex controller also has a built-in current transformer (CT) on each phase of the motor to provide current readings.

Power Wiring

See the product nameplate or [Table 7](#) for power lug termination information including:

- Lug wire capacity
- Tightening torque requirements
- Lug kit catalog numbers (108...1250 A devices)



ATTENTION: Failure of solid state power switching components can cause overheating due to a single-phase condition in the motor. Voltage could be present on output terminals when the SMC Flex controller has line voltage. To prevent injury or equipment damage, the following is recommended:

ATTENTION: Use of an isolation contactor or shunt trip type circuit breaker on the line side of the SMC Flex controller. This device should be capable of interrupting the motor's locked rotor current.

ATTENTION: Connection of this isolation device to an auxiliary contact on the SMC Flex controller. The auxiliary contact should be programmed for the fault condition. See [Chapter 4](#) for additional information on programming.

Line Connection

The SMC Flex by default is programmed to be connected to a line controlled motor, as shown in [Figure 34](#). These motors typically have 3 leads and must be rated between 1...1250 A. An optional isolation contactor can be added to the circuit to provide galvanic isolation of the motor and final electro-mechanical removal of power.

Figure 34 - Line-connected Wiring

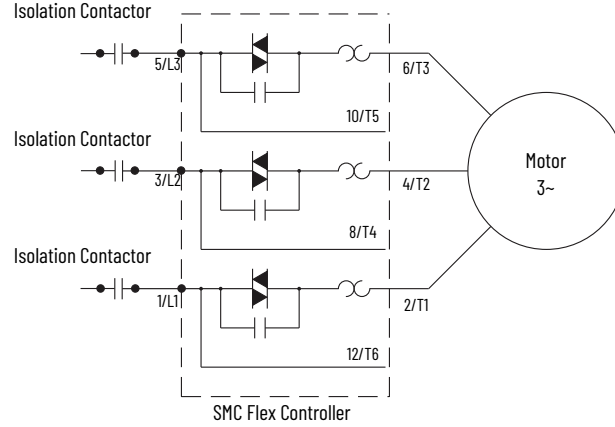

Delta Connection

You can program the SMC Flex controller and connect it to a delta-controlled motor as shown in [Figure 35](#). These motors typically have 6 or 12 leads and must be rated between 1.8...1600 A. We recommend that you add an isolation contactor to the circuit to provide galvanic isolation of the motor and final electromechanical removal of power.

Figure 35 - Delta-connected Wiring

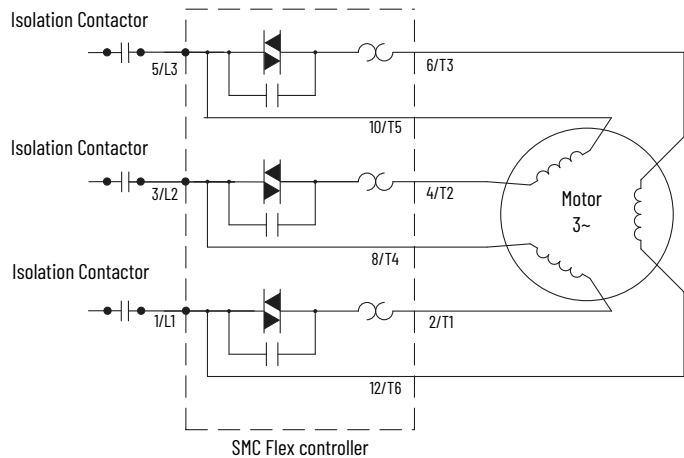

Power Lugs

Devices that are rated 108...1250 A require power lugs. In some cases, these lugs are sold in kits of three lugs. [Table 7](#) and [Table 8](#) list the number and type of lugs that are required.

[Table 7](#) lists the recommended lugs for the SMC Flex controller when it is configured as a line connection. [Table 8](#) lists the recommended lugs when using the SMC Flex controller with a delta connection. Note that devices rated 625...1250 A require the use of a power distribution block when they are used with a delta connection.



ATTENTION: Terminal covers are available for units rated 108...480 A which can make the product deadfront (IP2X) safe. See the SMC-3™, SMC Flex, and SMC-50™ Smart Motor Controllers Technical Data, publication [150-TD009](#) for the appropriate catalog numbers for ordering.

Table 7 - SMC Flex Controller Line Connection Lug Information—5...1250 A Devices

Controller Rating	Lug Kit Cat. No.	Wire Strip Length	Conductor Range	Max. No. Lugs/Pole		Tightening Torque	
				Line Side	Load Side	Wire – Lug	Lug – Busbar
5...85 A	—	18...20 mm	2.5...95 mm ² (#14...3/0 AWG)	—	—	11.3 N•m (100 lb.-in.)	—
108...135 A	199-LF1	18...20 mm	16...120 mm ² (#6...250 MCM)	1	1	31 N•m (275 lb.-in.)	17 N•m (150 lb.-in.)
201...251 A	199-LF1	18...20 mm	16...120 mm ² (#6...250 MCM)	2	2	31 N•m (275 lb.-in.)	23 N•m (200 lb.-in.)
317...480 A	199-LG1	18...25 mm	25...240 mm ² (#4...500 MCM)	2	2	42 N•m (375 lb.-in.)	28 N•m (250 lb.-in.)
625...780 A	100-DL630	32 mm / 64 mm	70...240 mm ² (2/0...500 MCM)	2	2	45 N•m (400 lb.-in.)	68 N•m (600 lb.-in.)
970 A	100-DL860	26 mm / 48 mm	120...240 mm ² (4/0...500 MCM)	1	1	45 N•m (400 lb.-in.)	68 N•m (600 lb.-in.)
1250 A ⁽¹⁾	100-DL630	32 mm / 64 mm	70...240 mm ² (2/0...500 MCM)	1	1	45 N•m (400 lb.-in.)	68 N•m (600 lb.-in.)
	100-DL860	26 mm / 48 mm	120...240 mm ² (4/0...500 MCM)	1	1		

(1) The 1250 A device requires one (1) each of Cat. No. 100-DL630 and 100-DL860.

Table 8 - SMC Flex Controller Delta Connection Lug Information (for Inside-the-Delta Applications)—108...1250 A Devices

Controller Rating	Lug Kit Cat. No.	Conductor Range	Max. No. Lugs/Pole		Tightening Torque	
			Line Side	Load Side	Wire – Lug	Lug – Busbar
108...135 A	1494R-N15	25...240 mm ² (#4...500 MCM)	1	See Table 7	42 N•m (375 lb.-in.)	17 N•m (150 lb.-in.)
201...251 A	1494R-N14	50...120 mm ² (1/0...250 MCM)	2		31 N•m (275 lb.-in.)	23 N•m (200 lb.-in.)
317...480 A	150-LG5MC	95...240 mm ² (3/0...500 MCM)	1		33.9 N•m (300 lb.-in.)	28 N•m (250 lb.-in.)
625...780 A ⁽¹⁾	—	25...240 mm ² (#4...500 MCM)	2		42 N•m (375 lb.-in.)	—
970...1250 A ⁽¹⁾	—	25...240 mm ² (#4...500 MCM)	4		42 N•m (375 lb.-in.)	—

(1) For 625...1250 A inside-the-delta connections, terminal blocks are required for line side connections. Required terminal blocks are as follows:
 - Allen-Bradley Part# 1492-BG (625...780 A: 2 per phase, 970...1250 A: 4 per phase). Short-circuit Protection = Fuses
 - Cooper Bussmann Part# 16504-2 (625...780 A: 1 per phase, 970...1250 A: 2 per phase). Short-circuit Protection = Circuit breaker

Control Power

This section explains the control power requirements for the SMC Flex controller.

Control Wiring

See the product nameplate for control terminal wire capacity and tightening torque requirements. Each control terminal can accept a maximum of two wires. See the product nameplate prior to applying control power. Depending on the specific application, additional control circuit transformer VA capacity may be required.

Controllers rated 5...480 A

SMC Flex controllers that are rated 5...480 A accept control power input of 100...240V AC or 24V AC/DC, (+10/-15%) single-phase, 50/60 Hz. A control power source of 125 VA is required. The control power requirement for the control module is 75 VA. The control power requirement for the fans is 20, 40, or 60 VA. The control module and fans are separately wired. The control module requirements are shown in [Table 9](#). The fans require additional power as shown in [Table 11](#).

Table 9 - Control Module Requirements

120...240V AC	Transformer	75 VA
24V AC	Transformer	130 VA
24V DC	Inrush Current	5 A
	Inrush Time	250 ms
	Transient Watts	60 W
	Transient Time	500 ms
	Steady State Watts	24 W
	Minimum Allen-Bradley Power Supply	1606-XLP50E

Controllers rated 625...1250 A

Controllers that are rated 625...1250 A require common control for proper operation. Control power is connected to the product through terminal block CP1, at terminals 1 and 4. This single connection point feeds the control module, contactors, and fans. Control power must be supplied as 110/120V AC or 230/240V AC, 50/60 Hz only. A control power source of at least 800 VA is required. The control power requirements include the control module (75 VA), bypass contactors (526 VA max), and fan power (150 VA).

Depending on the specific application, additional control circuit transformer VA capacity may be required.

Units with a control power rating of 230/240V AC have an undervoltage relay installed. Units built prior to 2014 may have potentiometers on the undervoltage relay. If potentiometers are present, you must set them according to [Figure 36](#). Units built later than 2014 may not have potentiometers, because the settings are programmed internally to the undervoltage relay and no adjustment is required.

Figure 36 - 230V Control Undervoltage Relay Settings for 625...1250 A Devices

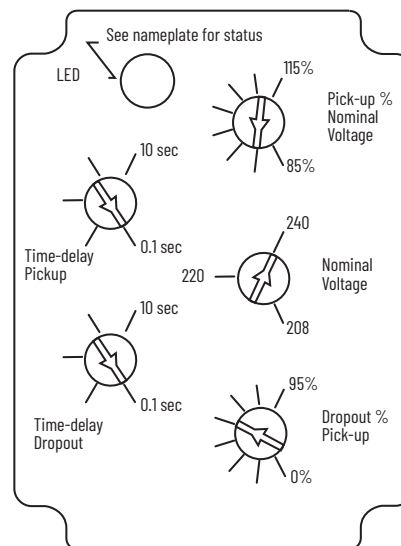

Figure 37 - Internal Wiring and 230V Control Undervoltage Relay Connection Diagram—625...1250 A Devices

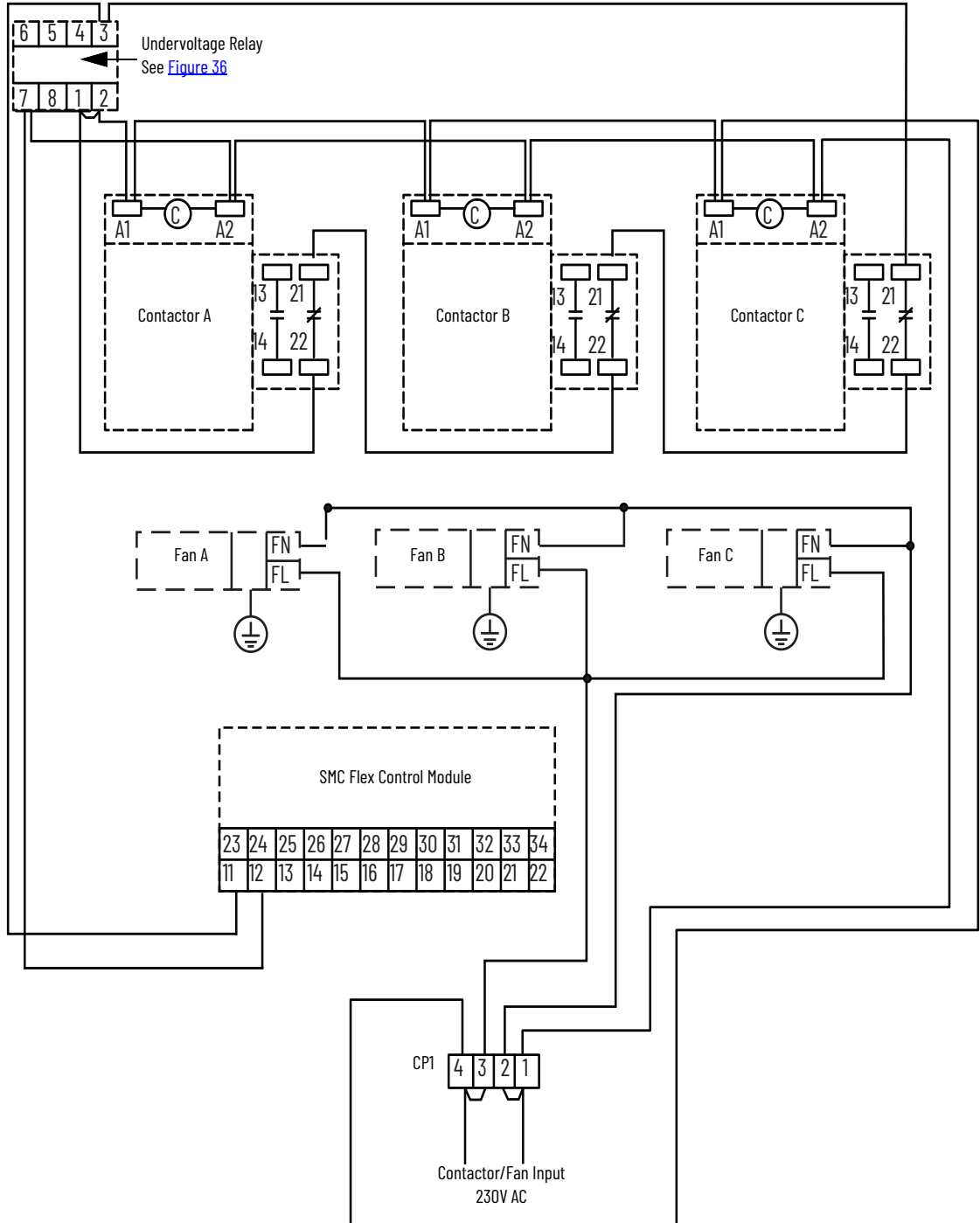
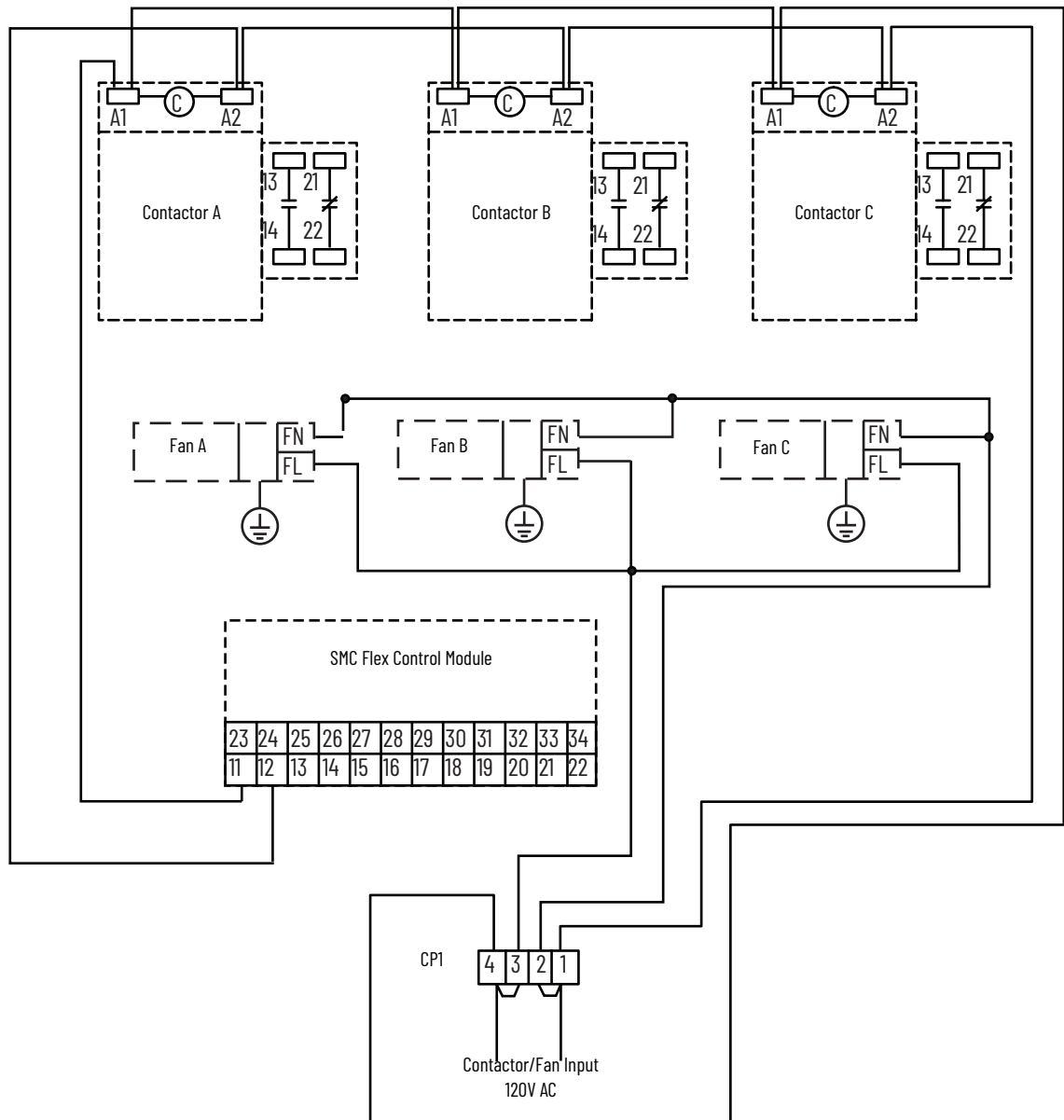

Figure 38 - Internal Wiring and 120V Control Connection Diagram—625...1250 A Devices



Control Wire Specifications

Table 10 lists the control terminal wire capacity, the tightening torque requirements, and the wire strip length. Each control terminal can accept a maximum of two wires.

Table 10 - Control Wiring and Tightening Torque

Wire Size	Torque	Wire Strip Length
0.75...2.5 mm ² (#18...14 AWG)	0.6 N•m (5 lb.-in.)	5.6...8.6 mm (0.22...0.34 in.)

Fan Power

Controllers that are rated 5...1250 A have heatsink fan(s). See [Table 11](#) for the heatsink fan control power VA requirements.

Fan Terminations

See [Figure 31](#), [Figure 32](#), and [Figure 33](#) for fan power connection locations.



ATTENTION: The fan jumpers have been factory installed for 110/120V AC input. See [Figure 39](#) for 220/240V AC fan wiring (5...480 A devices only).

Figure 39 - Power Terminations

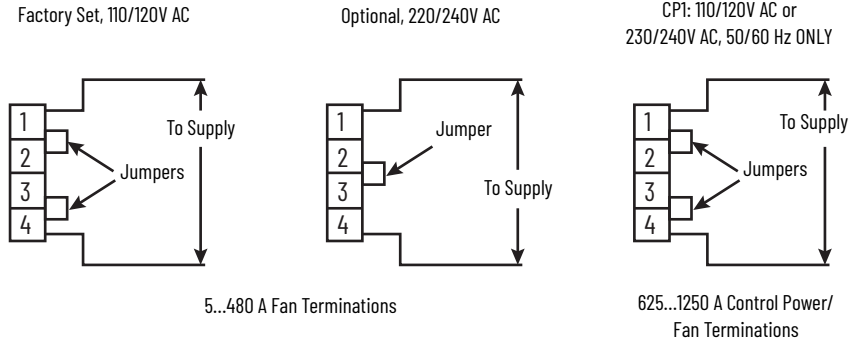

Table 11 - Heatsink Fan Control Power

Controller Rating	Heatsink Fan VA
5...135 A	20
201...251 A	40
317...480 A	60
625...780 A	150 (internally wired)
970...1250 A	150 (internally wired)

Control Terminal Designations

Figure 40 shows the 24 control terminals that are on the front of the controller.

Figure 40 - SMC Flex Controller Control Terminals



Table 12 - Control Terminal Designations

Terminal No.	Description	Terminal No.	Description
11	Control Power Input ^{(1) (2)}	23	PTC Input ⁽³⁾
12	Control Power Common ^{(1) (2)}	24	PTC Input ⁽³⁾
13	Controller Enable Input ⁽³⁾	25	Tach Input
14	Control Module Ground	26	Tach Input
15	Option Input #2 ^{(1) (3)}	27	Ground Fault Transformer Input ⁽³⁾
16	Option Input #1 ^{(1) (3)}	28	Ground Fault Transformer Input ⁽³⁾
17	Start Input ^{(1) (3)}	29	Aux. Contact #2 ^{(1) (4)}
18	Stop Input ^{(1) (3)}	30	Aux. Contact #2 ^{(1) (4)}
19	Aux. Contact #1 ^{(1) (4)}	31	Aux. Contact #3 ^{(1) (4)}
20	Aux. Contact #1 ^{(1) (4)}	32	Aux. Contact #3 ^{(1) (4)}
21	Not Used	33	Aux. Contact #4 ^{(1) (4)}
22	Not Used	34	Aux. Contact #4 ^{(1) (4)}

(1) RC snubbers are required on loads connected to auxiliary.

(2) Control power on units rated 625...1250 A is pre-wired internally, from terminal block CPl.

(3) Do not connect any additional loads to these terminals. These "parasitic" loads may cause problems with operation, which may result in false starting and stopping.

(4) External Bypass operates an external contactor and overload relay once the motor reaches full speed. The SMC Flex overload functionality, diagnostics and metering are disabled when the external bypass is activated. Proper sizing of the contactor and overload is required.

Standard Controller Wiring Diagrams

Figure 41 through Figure 51 show typical wiring for the SMC Flex controller.

Figure 41 - Typical Wiring Diagram for Standard Controllers

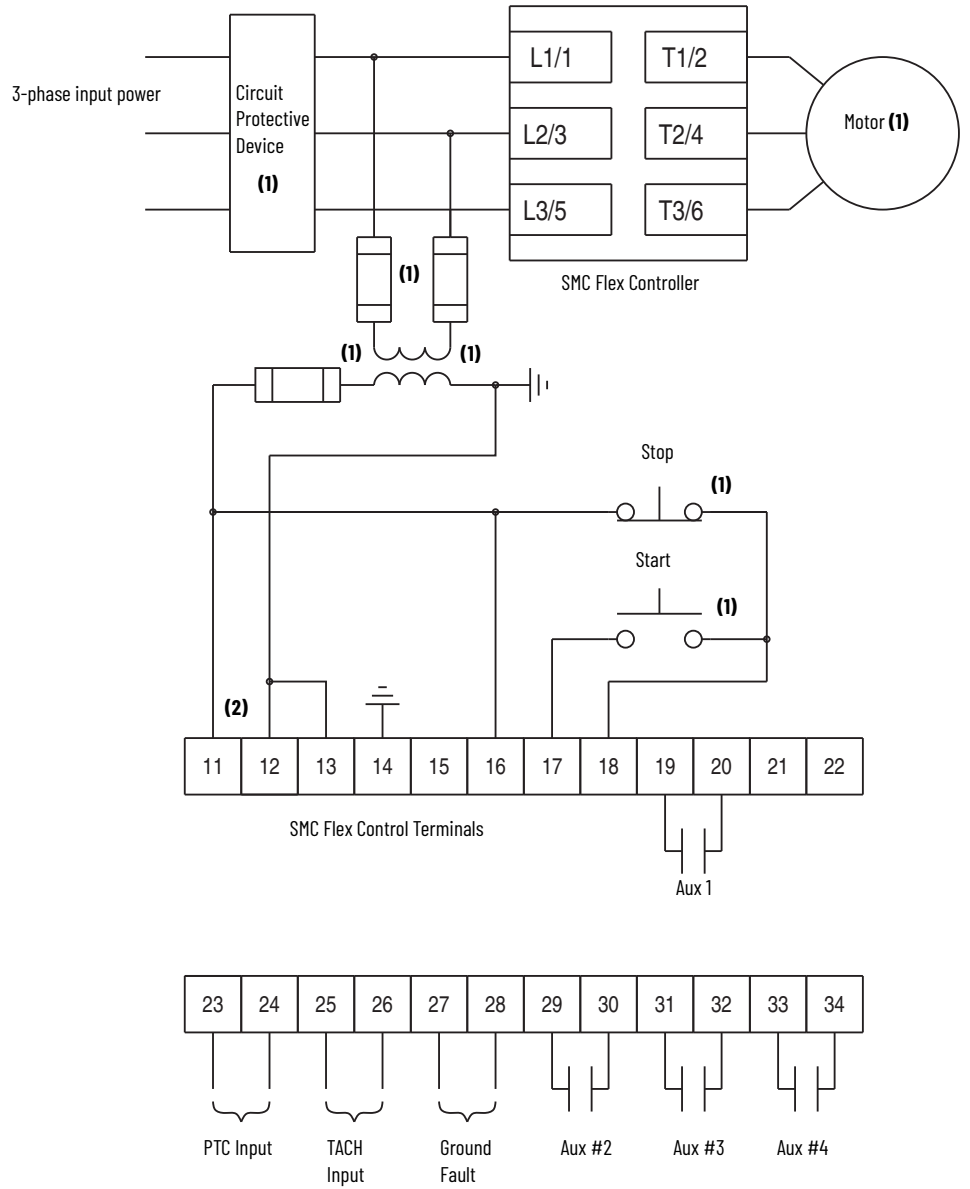

Note Number	Information
1	Customer supplied
2	See the controller nameplate to verify the rating of the control power input voltage. For units rated 625...1250 A, terminals 11 and 12 are factory pre-wired from terminal block CP1 - terminals 1 and 4.

Figure 42 - Typical Wiring Diagram for Two-wire Control with Stopping Control (No DPI Control)

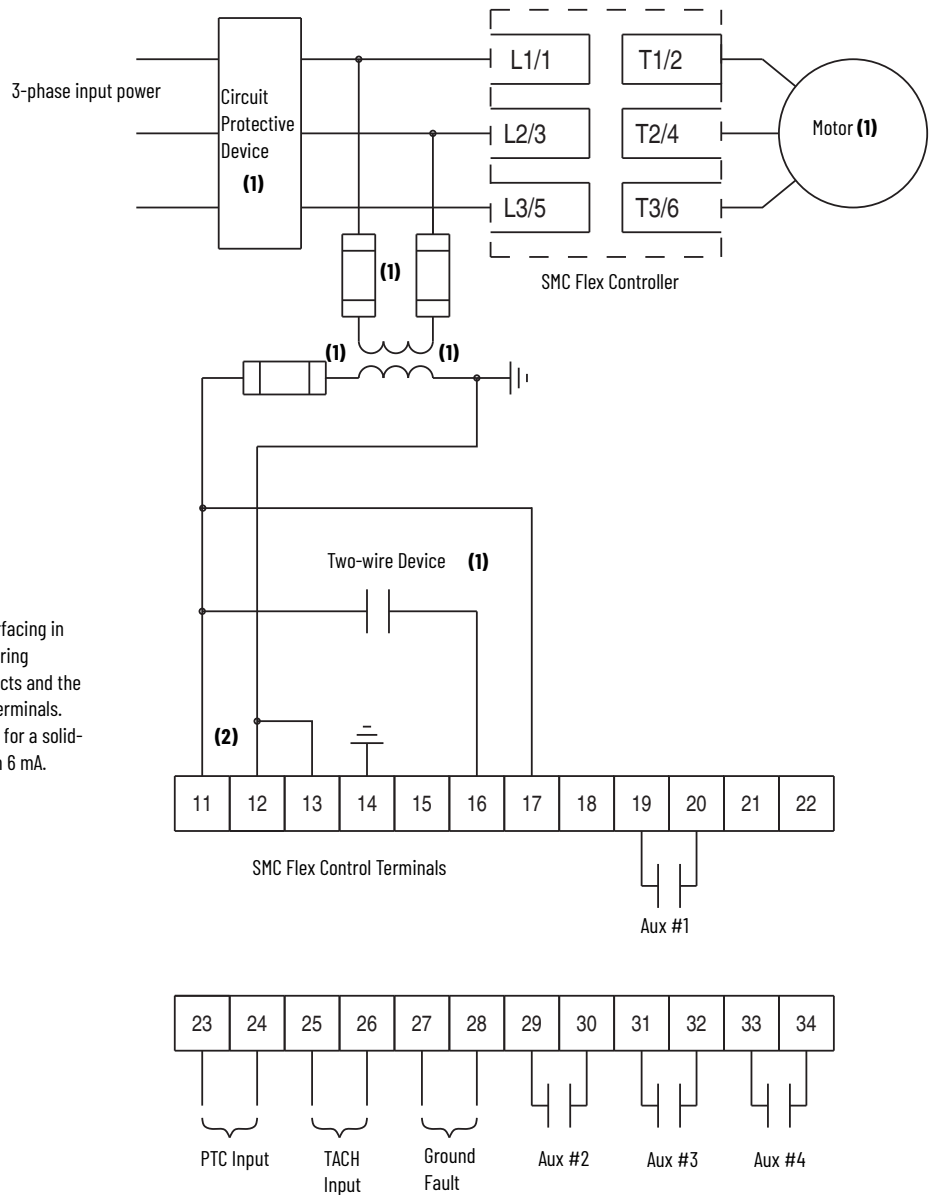

Programmable controller interfacing in this diagram refers to hard-wiring between the PLC output contacts and the SMC Flex controller's control terminals. The OFF state leakage current for a solid-state device must be less than 6 mA.

Note Number	Information
1	Customer supplied
2	See the controller nameplate to verify the rating of the control power input voltage. For units rated 625...1250 A, terminals 11 and 12 are factory pre-wired from terminal block CP1 - terminals 1 and 4.

Figure 43 - Typical Wiring Diagram for Dual Ramp Applications

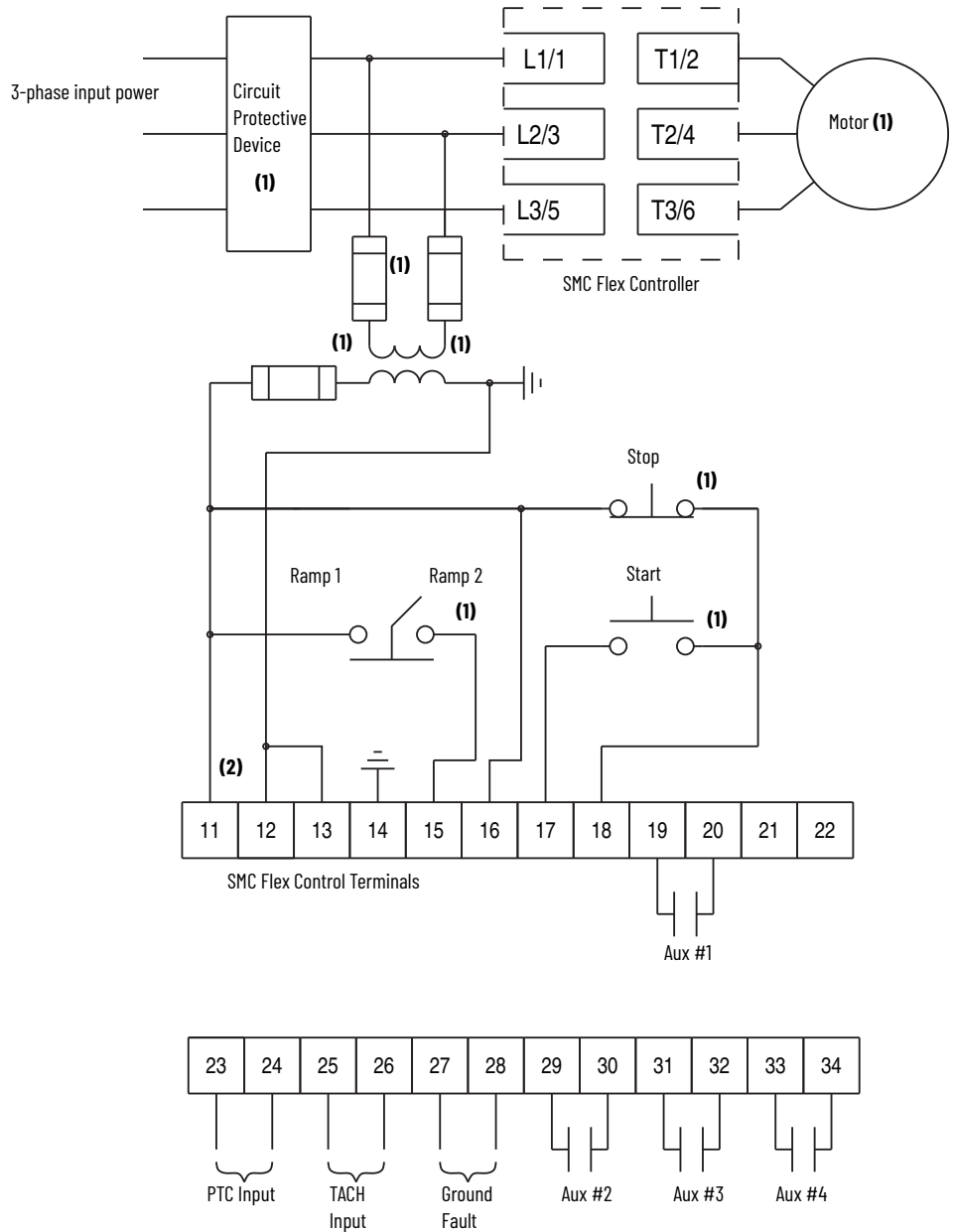

Note Number	Information
1	Customer supplied
2	See the controller nameplate to verify the rating of the control power input voltage. For units rated 625...1250 A, terminals 11 and 12 are factory pre-wired from terminal block CP1 - terminals 1 and 4.

Use [Figure 44](#) when start-stop originates from either a Bulletin 20-HIM LCD interface module or a Bulletin 20-COMM communication module that is connected to the SMC Flex controller.

Logic mask must be properly configured. See [page 93](#).

Figure 44 - Typical Wiring Diagram for Start-Stop Control via DPI Communications

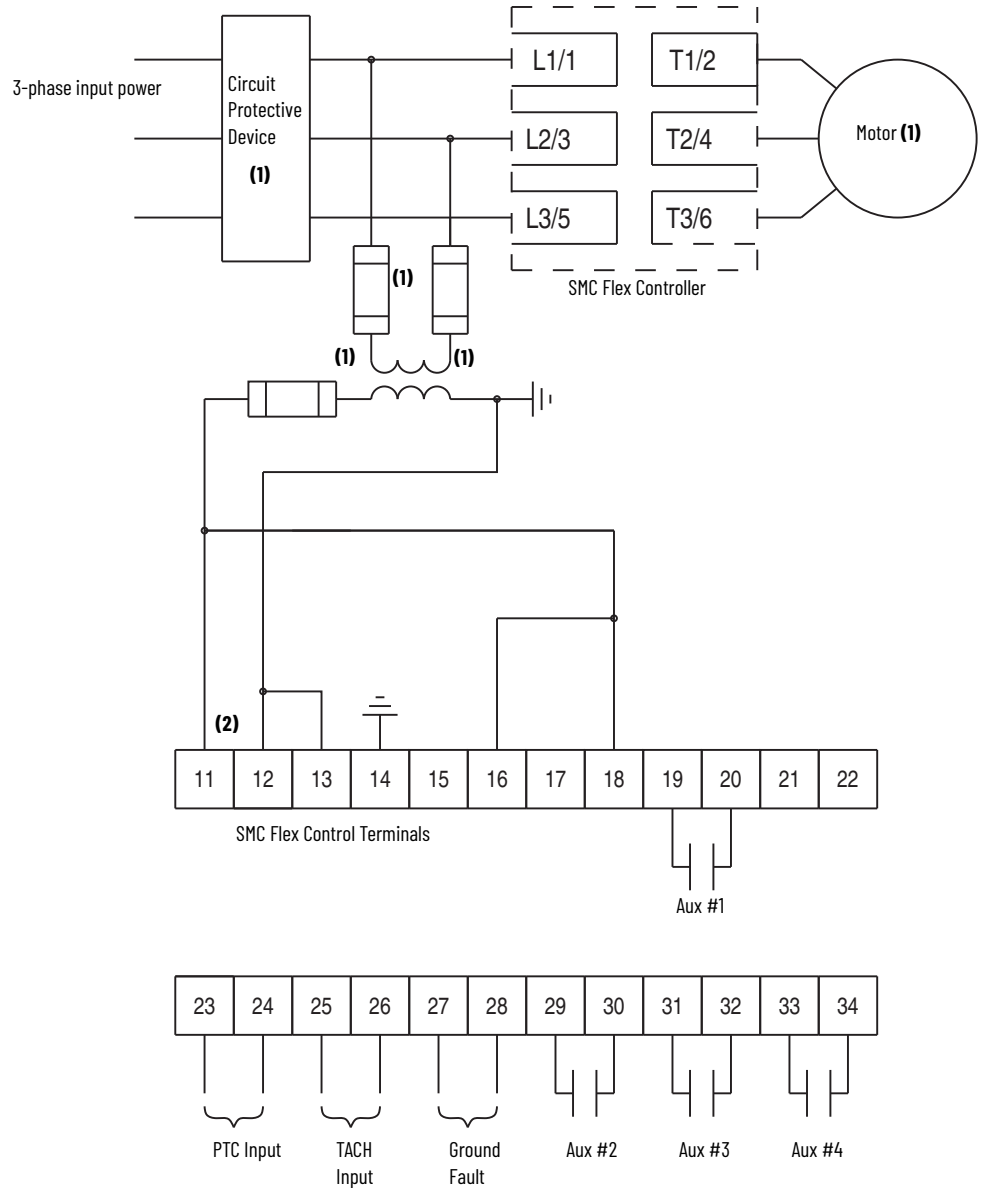

Note Number	Information
1	Customer supplied
2	See the controller nameplate to verify the rating of the control power input voltage. For units rated 625...1250 A, terminals 11 and 12 are factory pre-wired from terminal block CP1 - terminals 1 and 4.

Figure 45 - Typical Wiring Diagram for Retrofit Applications

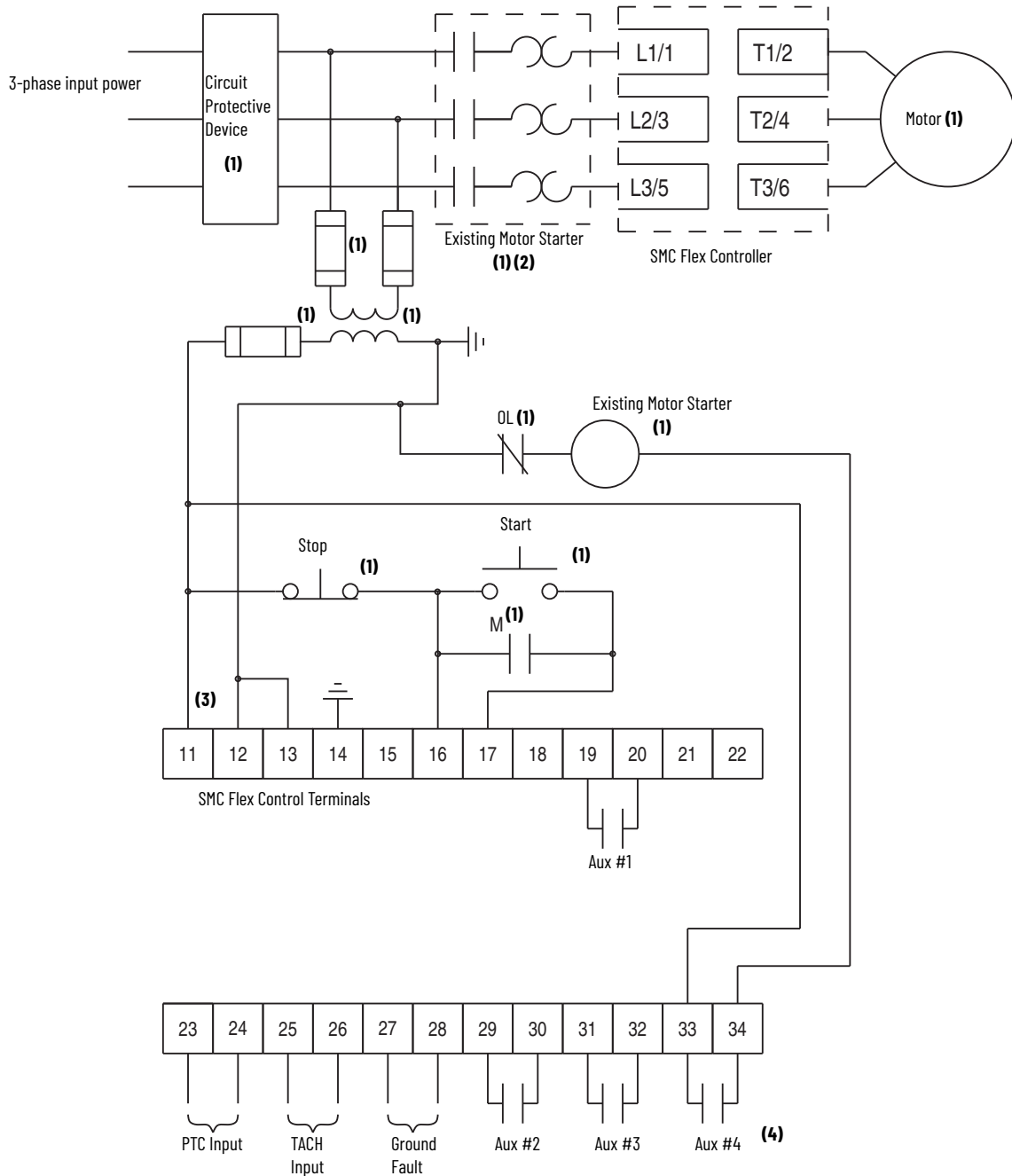

Note Number	Information
1	Customer supplied
2	Overload protection should be disabled in the SMC Flex controller.
3	See the controller nameplate to verify the rating of the control power input voltage. For units rated 625...1250 A, terminals 11 and 12 are factory pre-wired from terminal block CP1 - terminals 1 and 4.
4	Aux #4 should be set for normal operation

Figure 46 - Typical Wiring Diagram for Isolation Applications (DPI also)

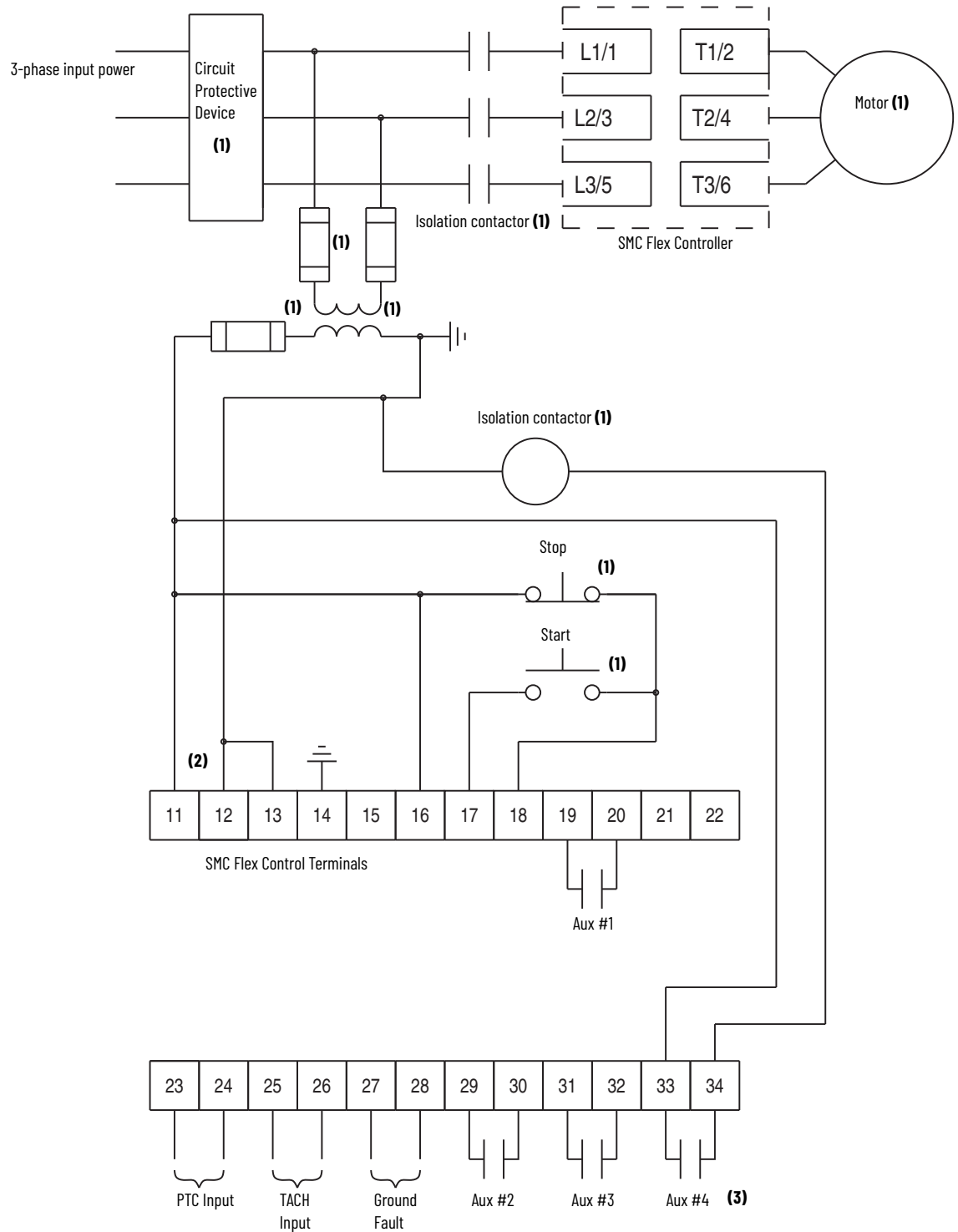

Note Number	Information
1	Customer supplied
2	See the controller nameplate to verify the rating of the control power input voltage. For units rated 625...1250 A, terminals T1 and T2 are factory pre-wired from terminal block CP1 - terminals 1 and 4.
3	Aux #4 should be set for normal operation

Figure 47 - Typical Wiring Diagram for Shunt Trip Applications

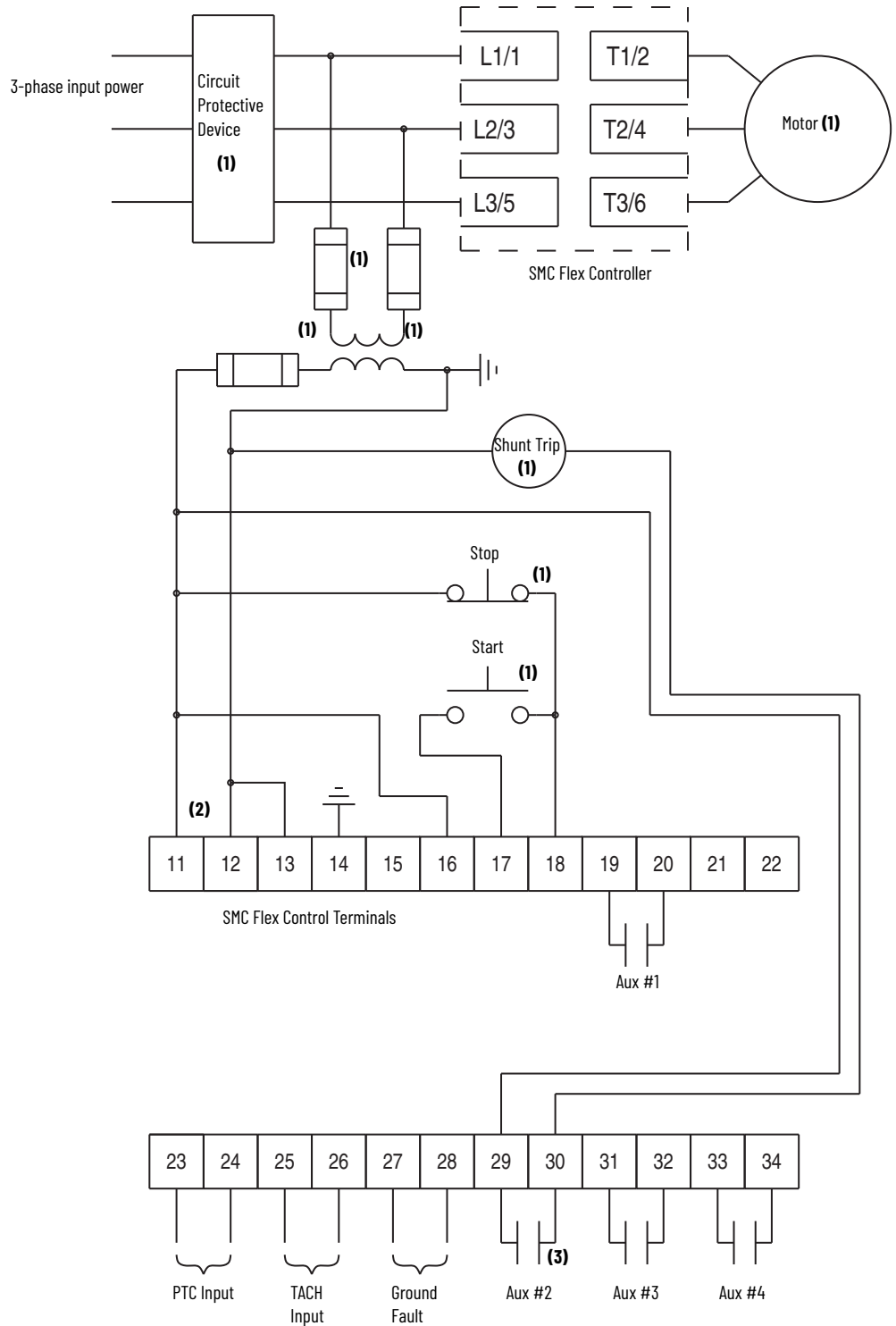

Note Number	Information
1	Customer supplied
2	See the controller nameplate to verify the rating of the control power input voltage. For units rated 625...1250 A, terminals 11 and 12 are factory pre-wired from terminal block CP1 - terminals 1 and 4.
3	Aux #2 should be set for fault operation

Figure 48 - Typical Wiring Diagram for Single-Speed Reversing Applications

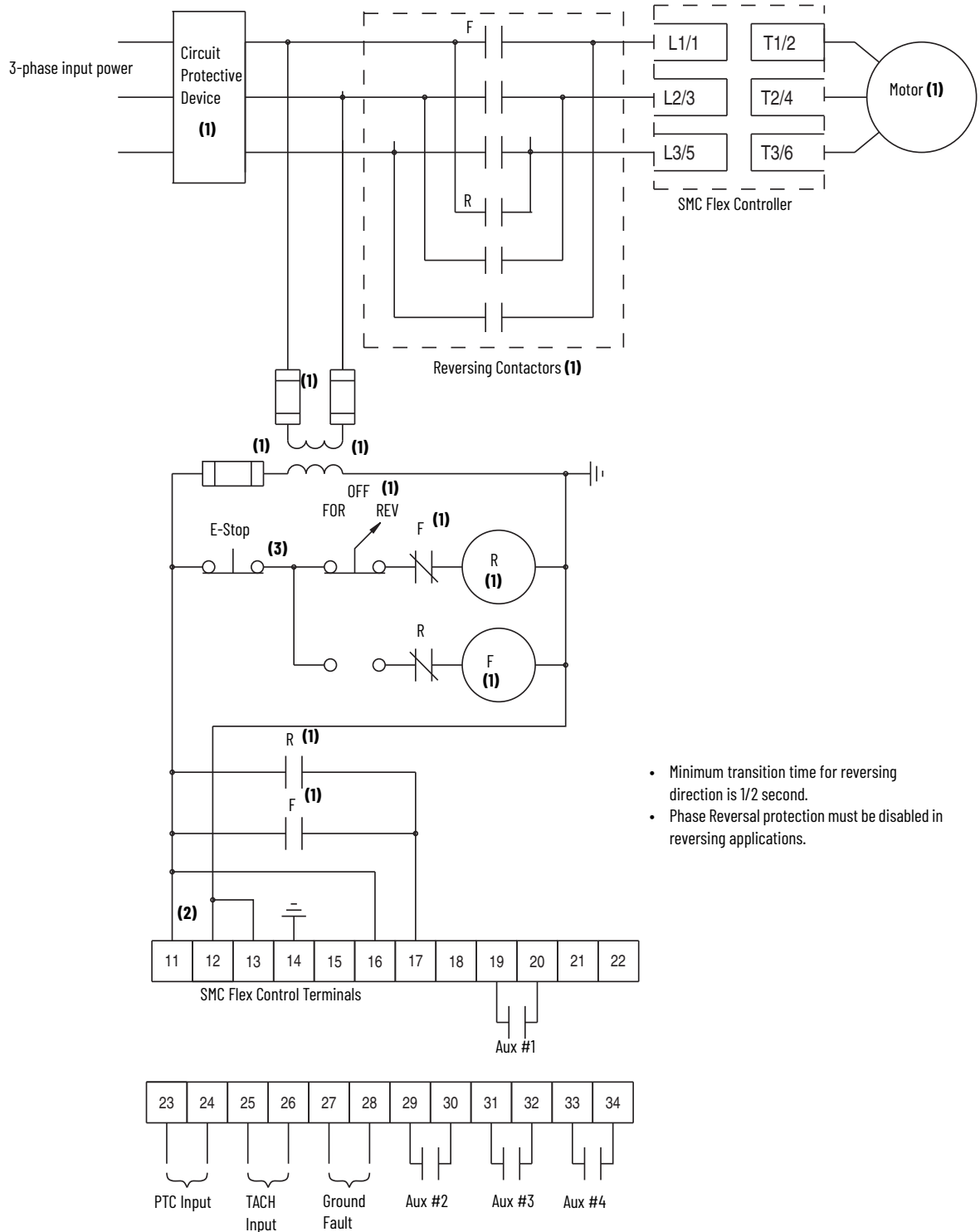

- Minimum transition time for reversing direction is 1/2 second.
- Phase Reversal protection must be disabled in reversing applications.

Note Number	Information
1	Customer supplied
2	See the controller nameplate to verify the rating of the control power input voltage. For units rated 625...1250 A, terminals T1 and T2 are factory pre-wired from terminal block CP1 - terminals 1 and 4.
3	Maintained push button.

Figure 49 - Typical Wiring Diagram for Two-speed Applications

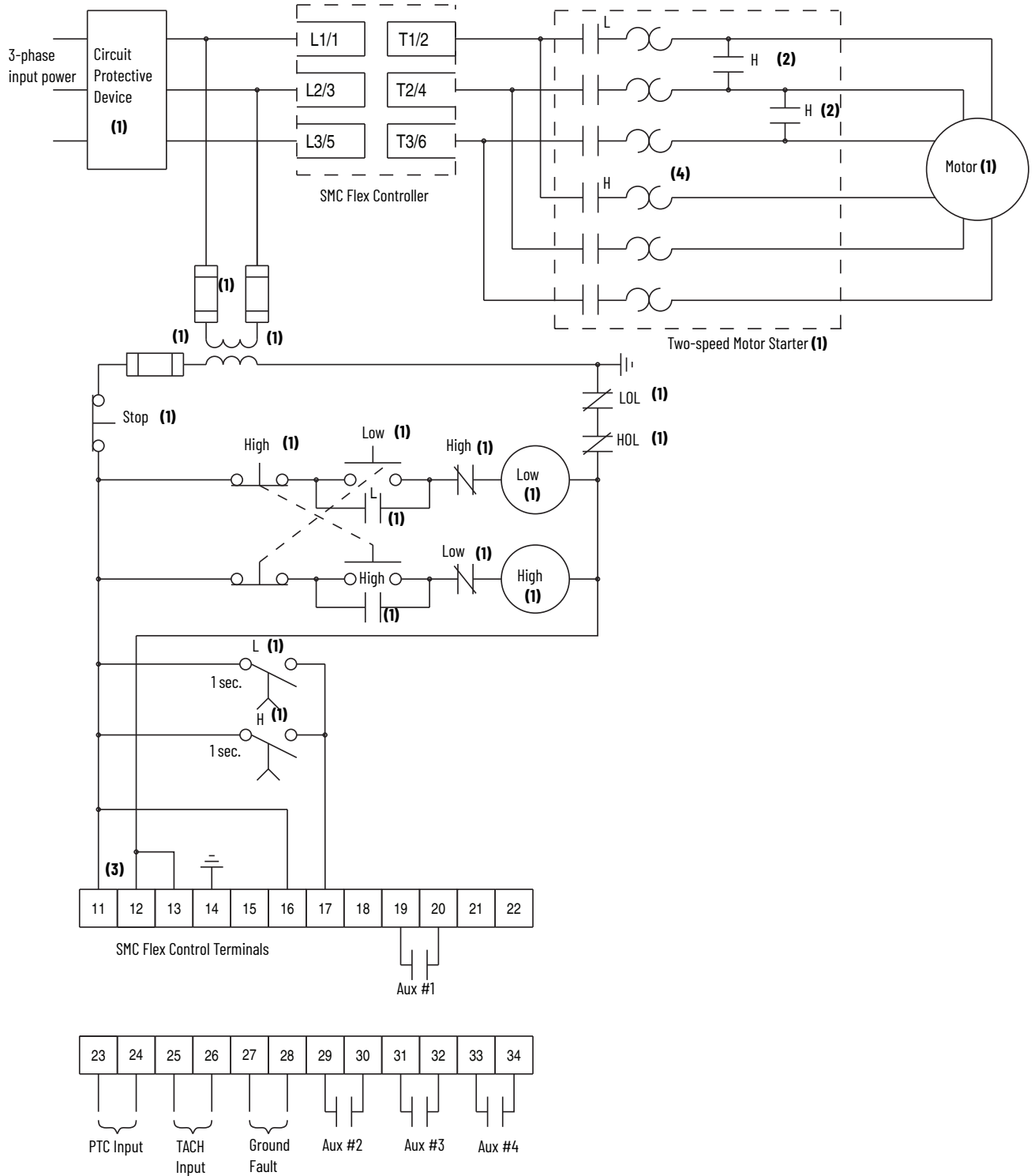

Note Number	Information
1	Customer supplied
2	Two-speed, consequent pole installations.
3	See the controller nameplate to verify the rating of the control power input voltage. For units rated 625...1250 A, terminals 11 and 12 are factory pre-wired from terminal block CP1 - terminals 1 and 4.
4	Overload must be disabled in SMC Flex controller.

Figure 50 - Typical Wiring Diagram for SMC-Off-Bypass Control

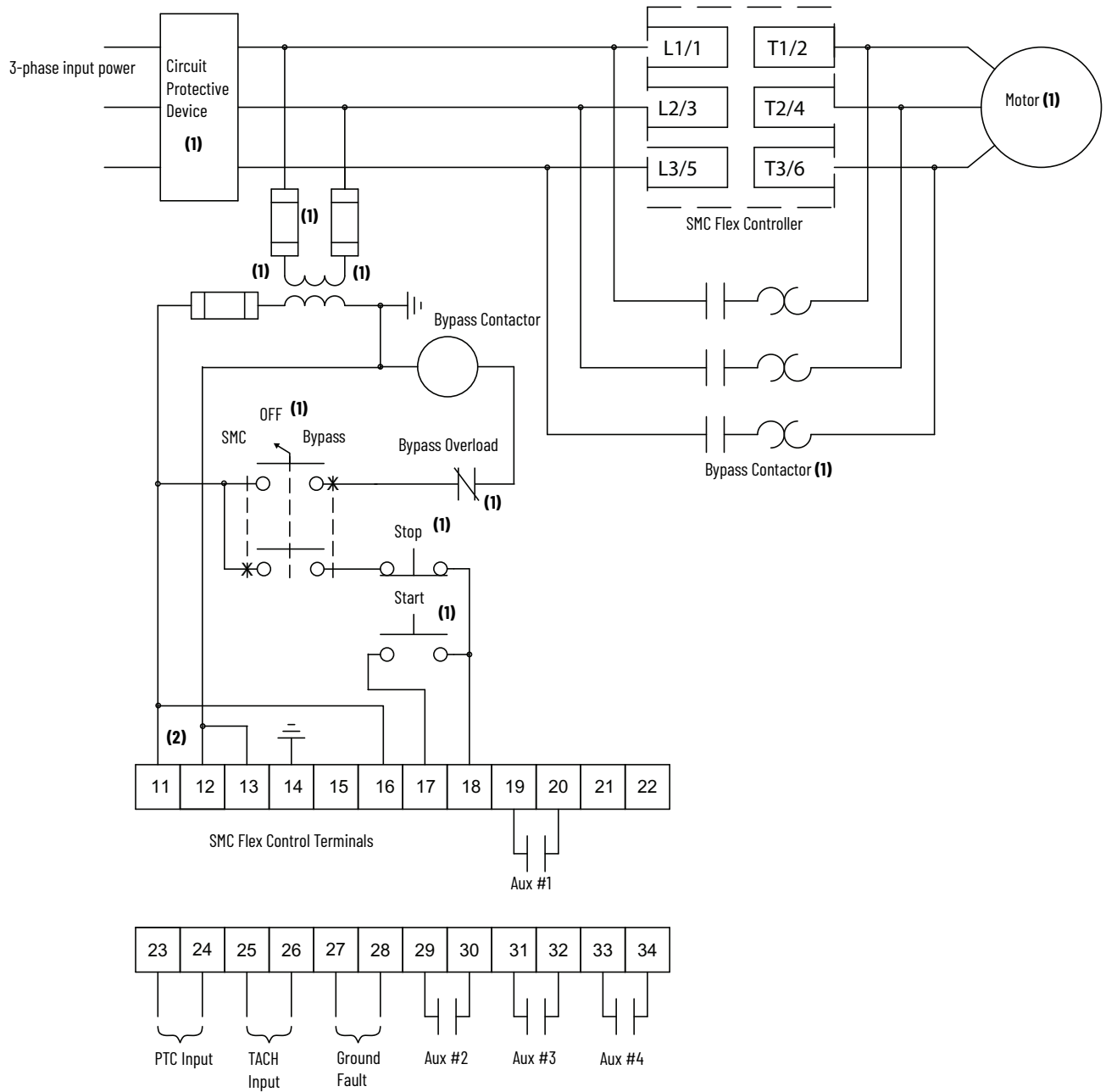

Note Number	Information
1	Customer supplied
2	See the controller nameplate to verify the rating of the control power input voltage. For units rated 625...1250 A, terminals 11 and 12 are factory pre-wired from terminal block CP1 - terminals 1 and 4.

Figure 51 - Typical Wiring Diagram for Hand-Off-Auto Control with Stop Option and Start/Stop Push Buttons

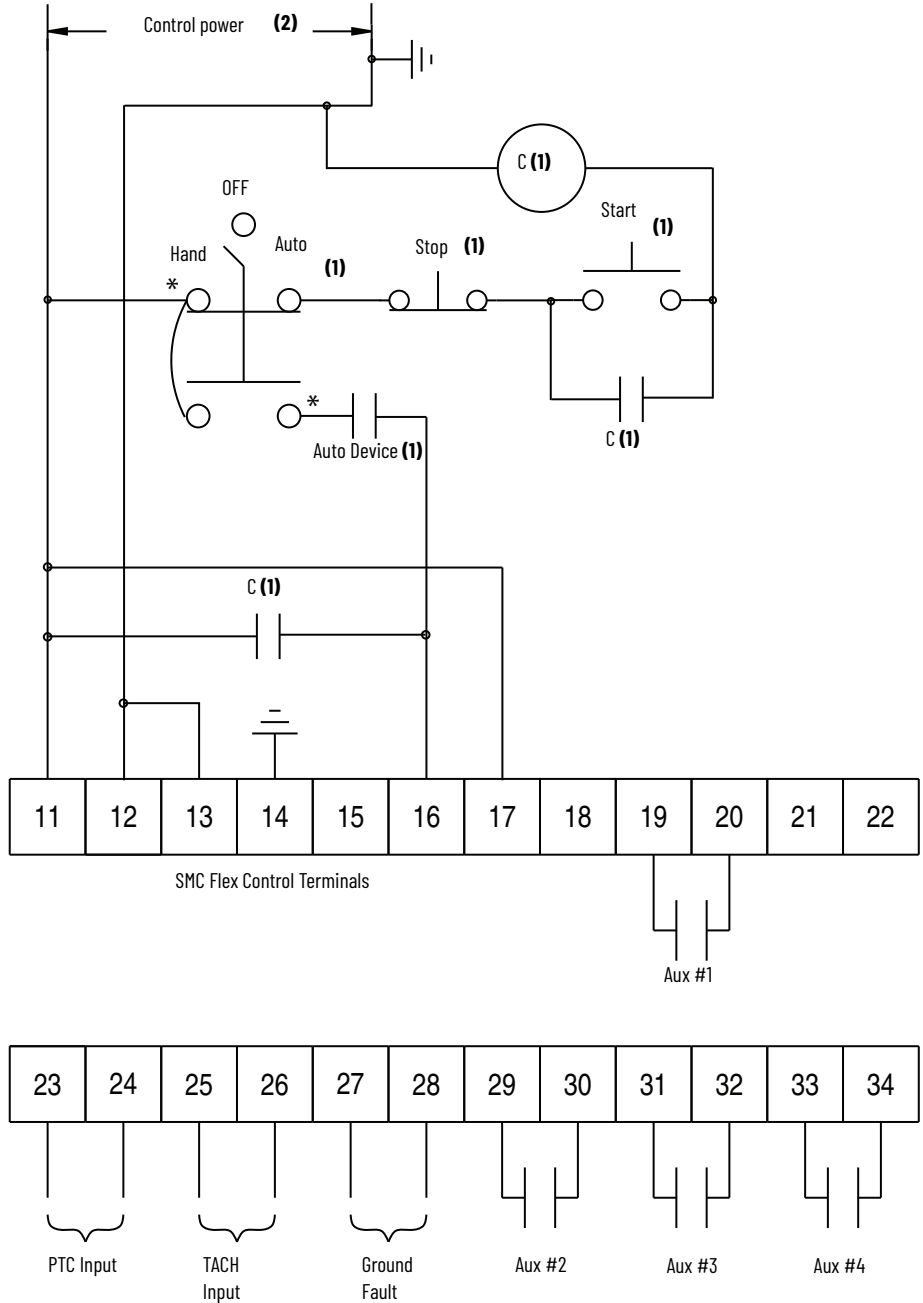

Note Number	Information
1	Customer supplied
2	See the controller nameplate to verify the rating of the control power input voltage. For units rated 625...1250 A, terminals 11 and 12 are factory pre-wired from terminal block CP1 - terminals 1 and 4.

Soft Stop, Pump Control, and SMB Smart Motor Braking

Figure 52 through Figure 55 show typical wiring for the Soft Stop, Pump Control, and SMB Smart Motor Braking options.

Figure 52 - Typical Wiring Diagram

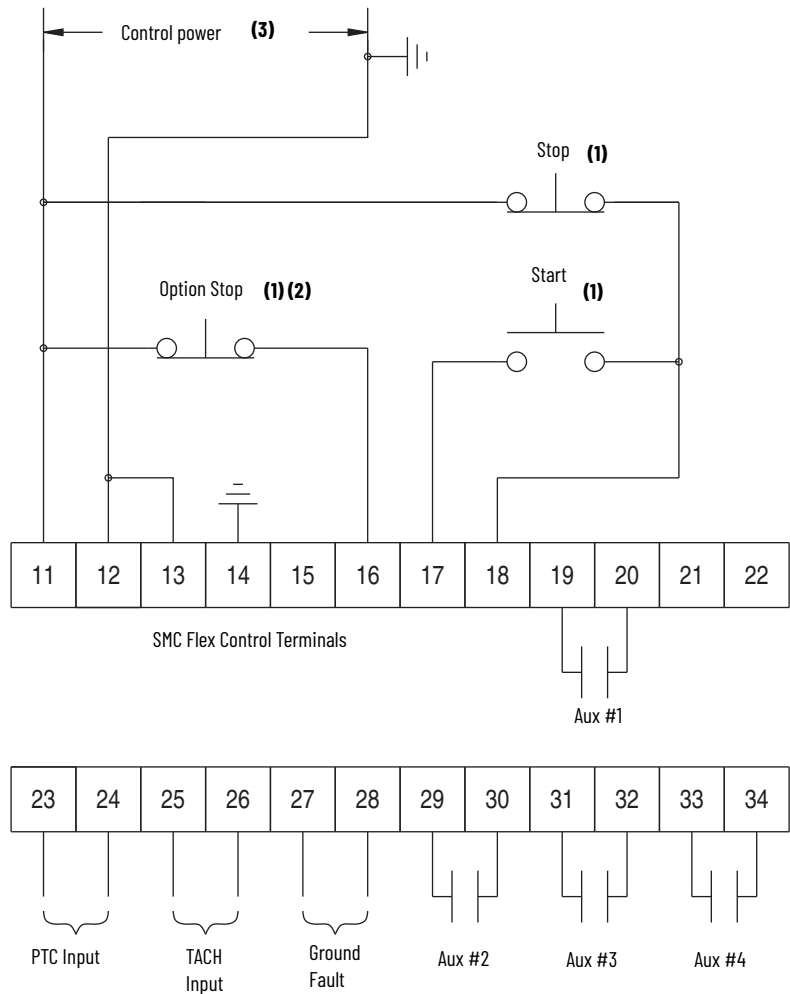

Note Number	Information
1	Customer supplied
2	Soft Stop, Pump Stop, or Brake.
3	See the controller nameplate to verify the rating of the control power input voltage. For units rated 625...1250 A, terminals 11 and 12 are factory pre-wired from terminal block CP1 - terminals 1 and 4.

Figure 53 - Typical Retrofit Wiring Diagram

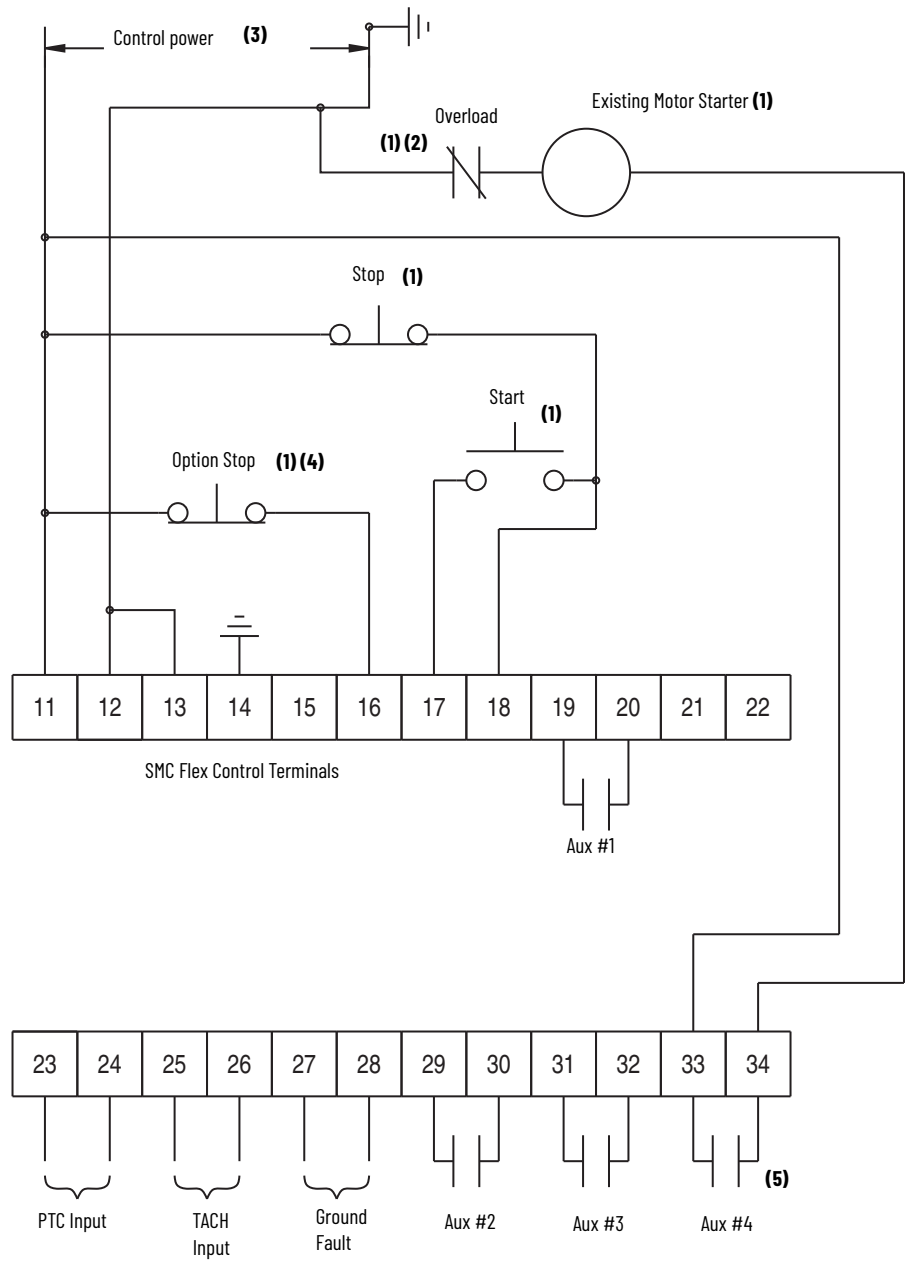

Note Number	Information
1	Customer supplied
2	Overload protection should be disabled in the SMC Flex controller.
3	See the controller nameplate to verify the rating of the control power input voltage. For units rated 625...1250 A, terminals 11 and 12 are factory pre-wired from terminal block CP1 - terminals 1 and 4.
4	Soft Stop, Pump Stop, or Brake.
5	Aux #4 should be set to normal operation.

Figure 54 - Typical Wiring Diagram for Applications That Require an Isolation Contactor

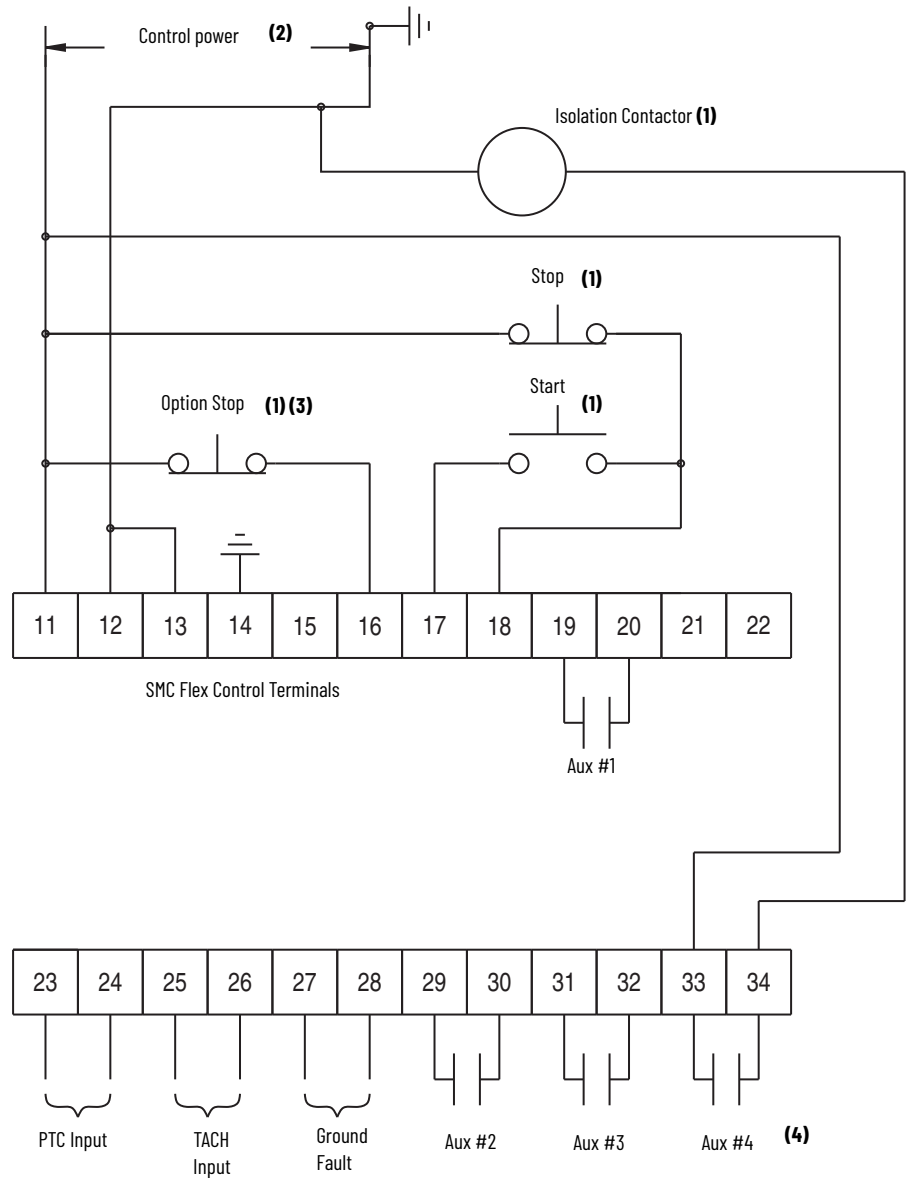

Note Number	Information
1	Customer supplied
2	See the controller nameplate to verify the rating of the control power input voltage. For units rated 625...1250 A, terminals 11 and 12 are factory pre-wired from terminal block CP1 - terminals 1 and 4.
3	Soft Stop, Pump Stop, or Brake.
4	Aux #4 should be set to normal operation.

Figure 55 - Typical Wiring Diagram for Hand-Off-Auto (DPI) Control (Soft Stop, Braking, and Pump Control Only)

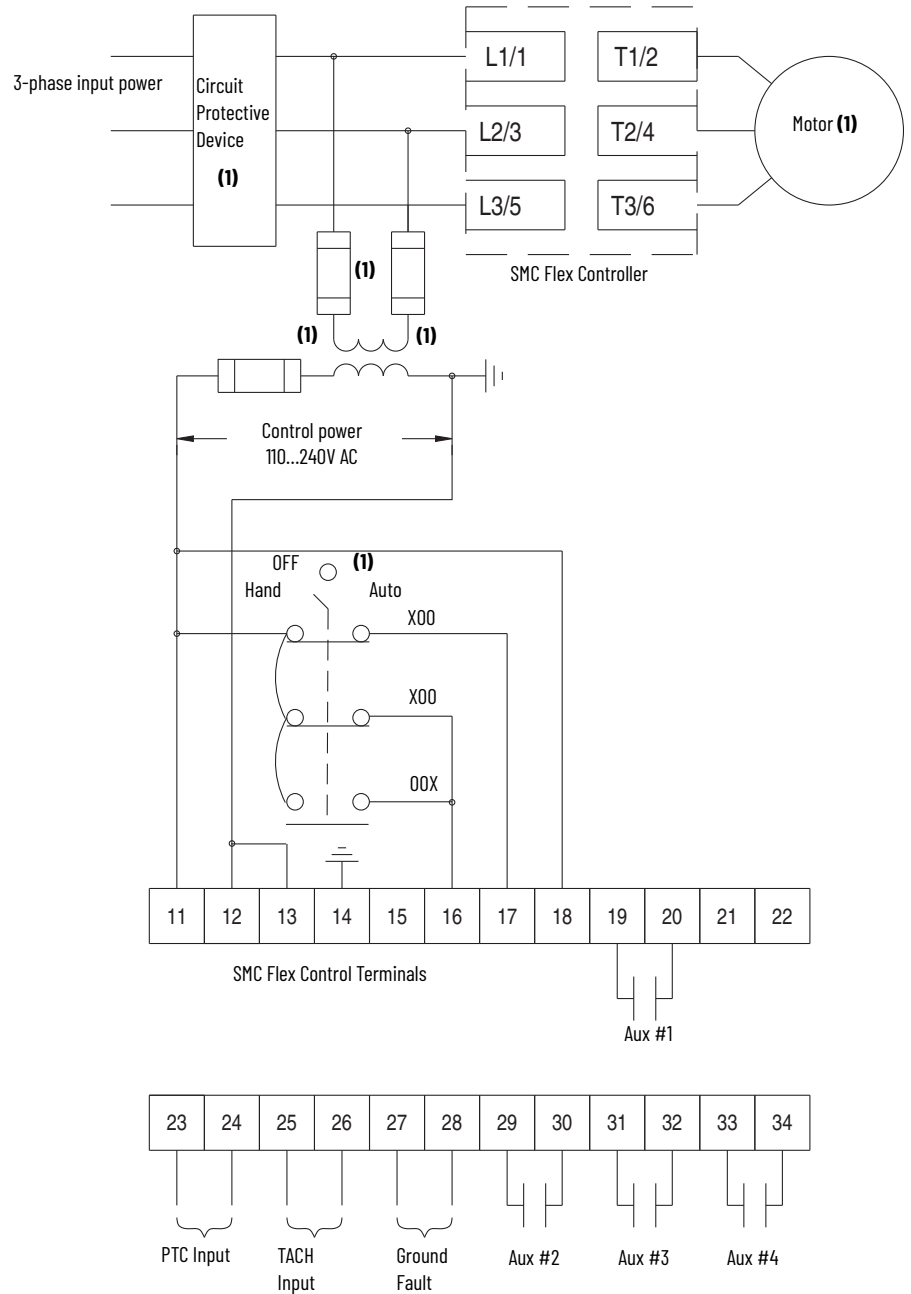

Note Number	Information
1	Customer supplied

Preset Slow Speed

Figure 56 and Figure 57 show typical wiring examples for Preset Slow Speed.

Figure 56 - Typical Wiring Diagram for Preset Slow Speed

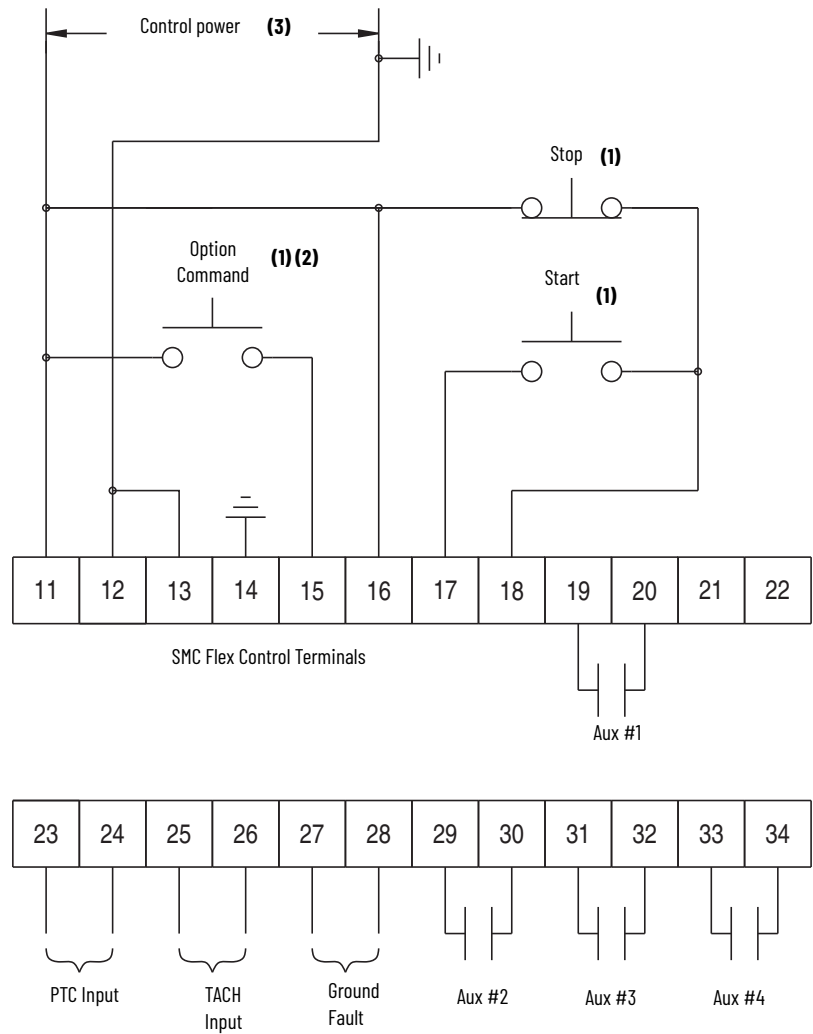

Note Number	Information
1	Customer supplied
2	Slow Speed.
3	See the controller nameplate to verify the rating of the control power input voltage. For units rated 625...1250 A, terminals 11 and 12 are factory pre-wired from terminal block CP1 - terminals 1 and 4.

Figure 57 - Typical Slow Speed Wiring Diagram for Hand-Off-Auto (DPI) Control

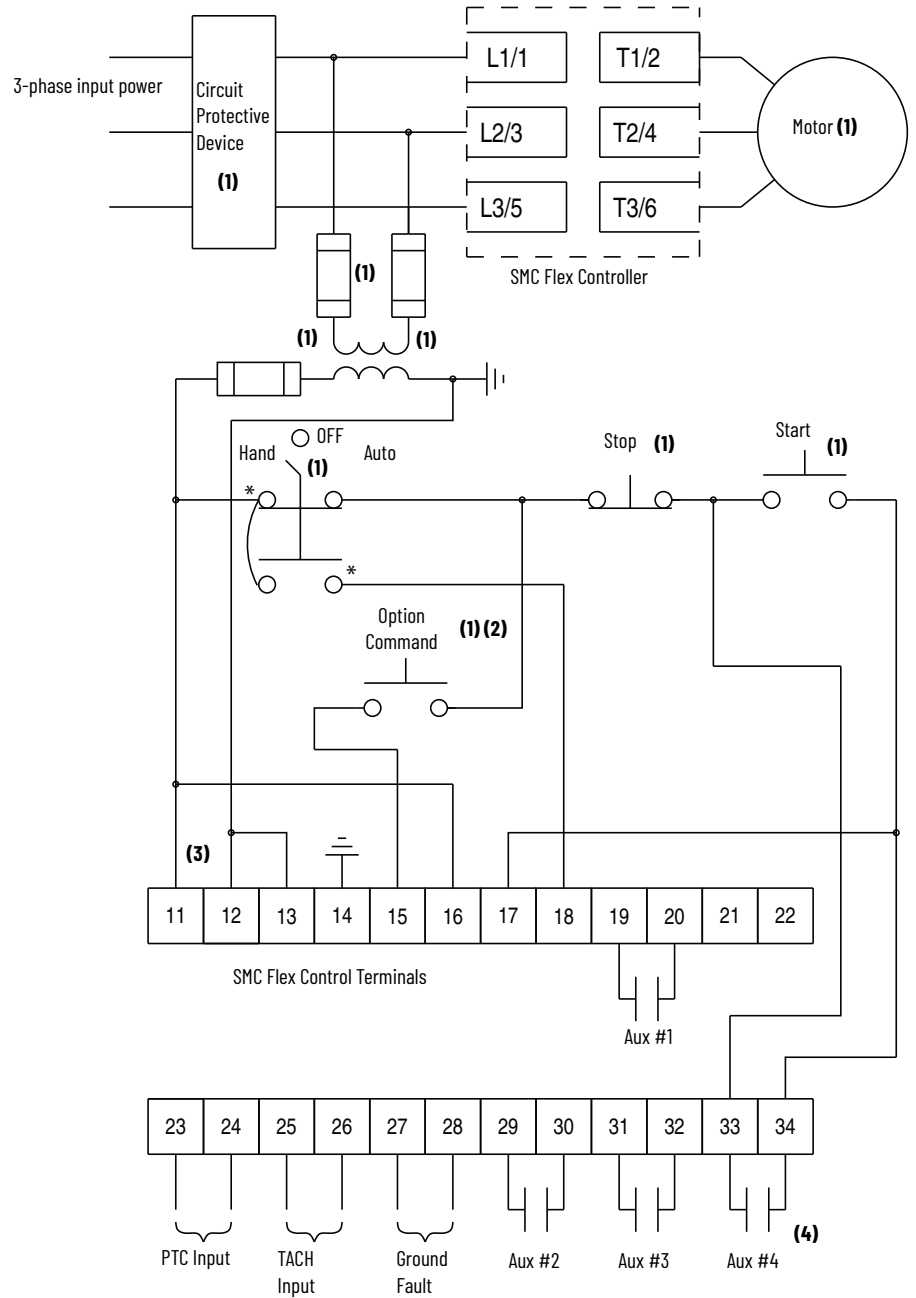

Note Number	Information
1	Customer supplied
2	Slow Speed
3	See the controller nameplate to verify the rating of the control power input voltage. For units rated 625...1250 A, terminals 11 and 12 are factory pre-wired from terminal block CP1 - terminals 1 and 4.
4	Aux #4 should be set to normal operation.

Slow Speed with Braking

Figure 58 shows the wiring for the Slow Speed with Braking option.

Figure 58 - Typical Wiring Diagram for Slow Speed with Braking with an Isolation Contactor

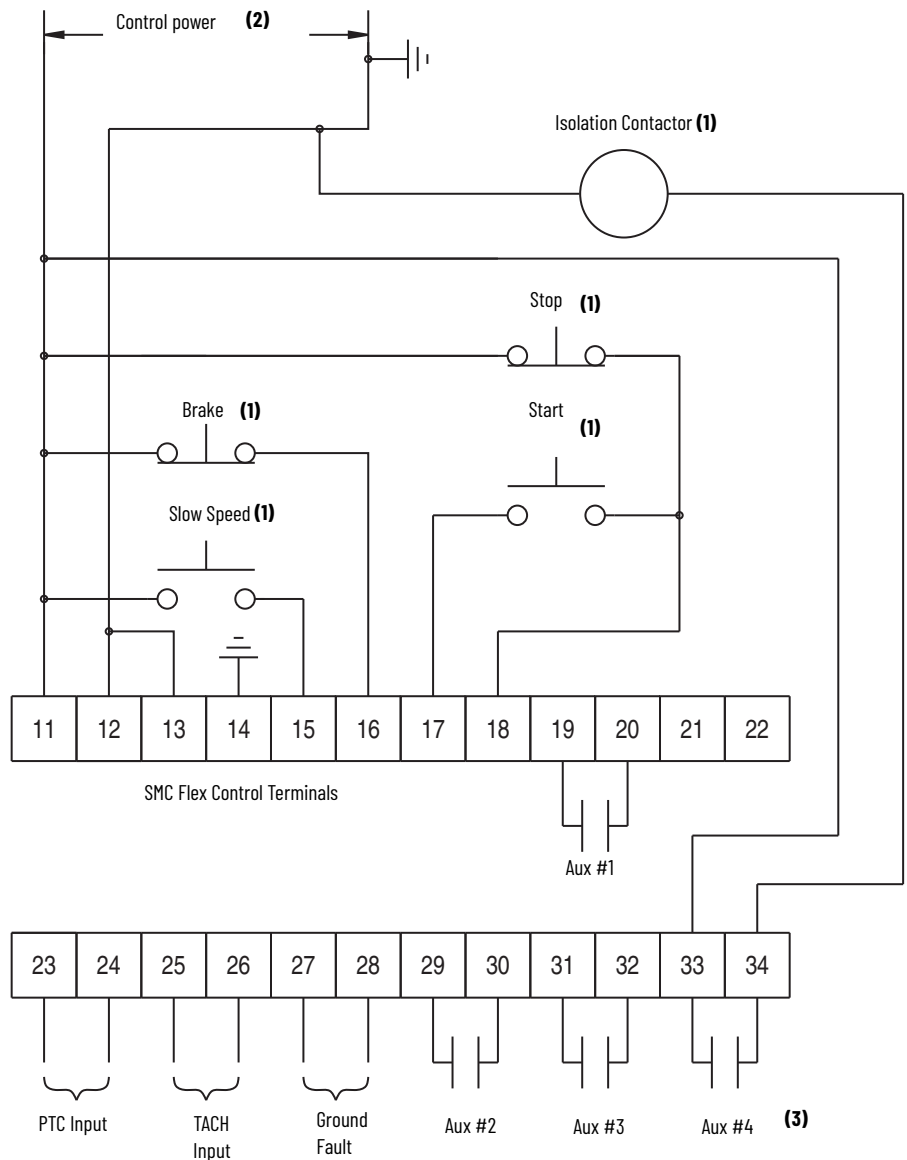

Note Number	Information
1	Customer supplied
2	See the controller nameplate to verify the rating of the control power input voltage. For units rated 625...1250 A, terminals 11 and 12 are factory pre-wired from terminal block CP1 - terminals 1 and 4.
3	Aux #4 should be set to normal operation.

Sequence of Operation

Figure 59 through Figure 64 show the different operation sequences for the Soft Stop, Preset Slow Speed, Pump Control, SMB Smart Motor Braking, Accu-Stop, and Slow Speed with Braking options.



ATTENTION: You are responsible for determining which stopping mode is best suited to the application and will meet applicable standards for operator safety on a particular machine.

Figure 59 - Soft Stop Sequence of Operation

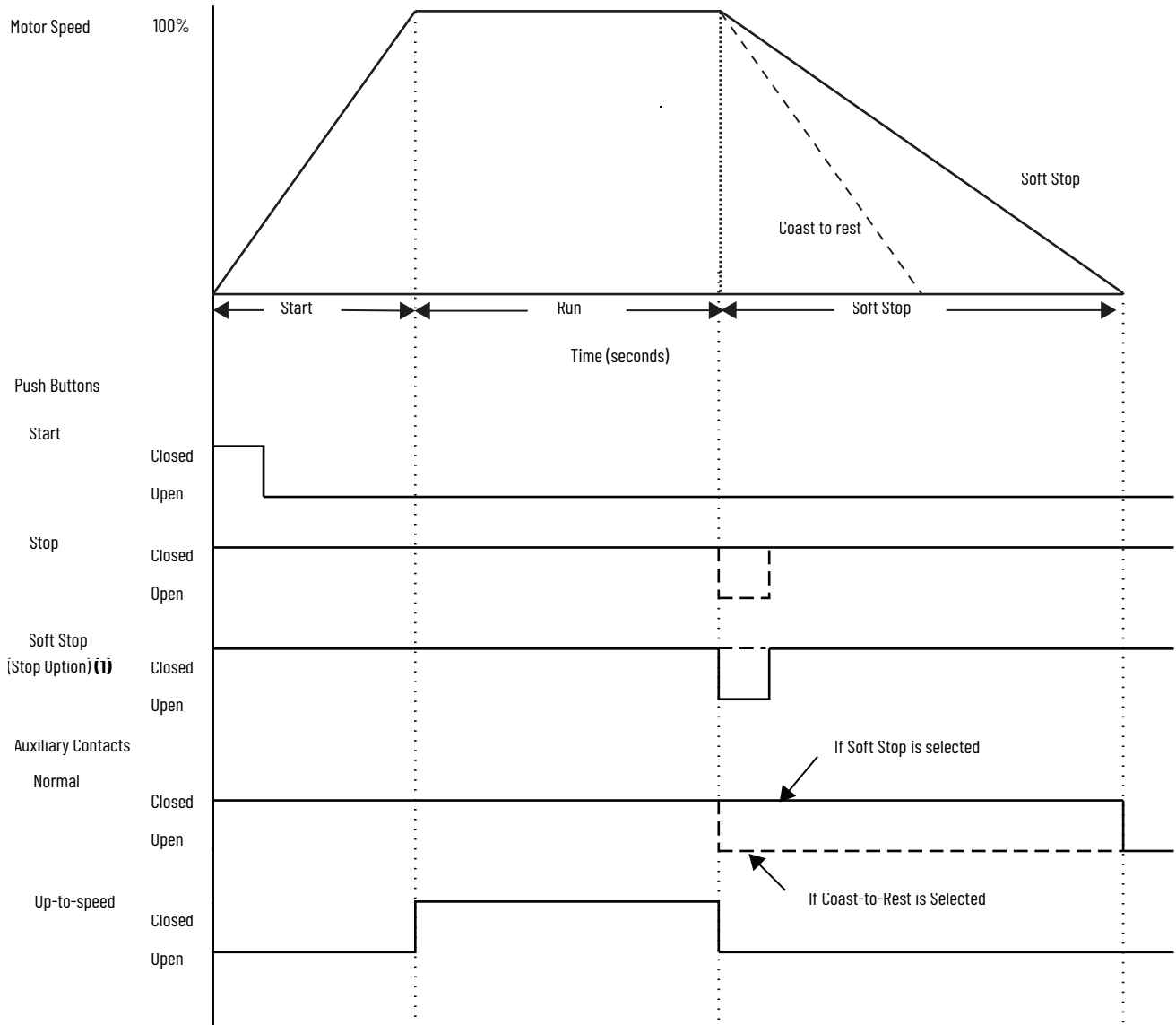

Note Number	Information
1	With the Stop Mode, Parameter 32, configured for Soft Stop and with the Input push button configured for the Stop Option.

Figure 60 - Preset Slow Speed Sequence of Operation

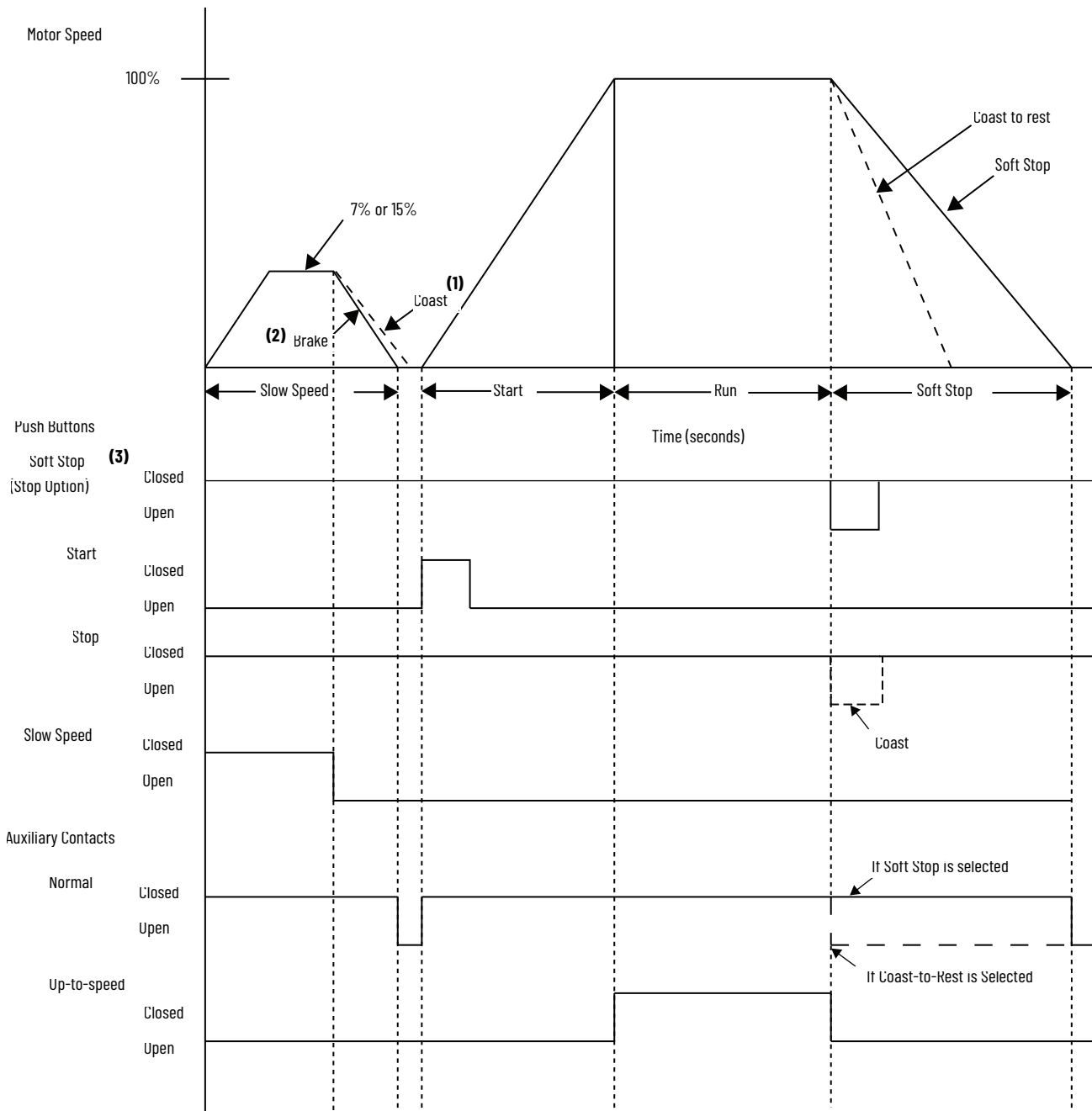

Note Number	Information
1	Coast if Stopping Current, Parameter 43, = 0.
2	Brake if Stopping Current, Parameter 43, > 0.
3	With the Stop Mode, Parameter 32, configured for Soft Stop and with the Input push button configured for the Stop Option.

Figure 61 - Pump Control Sequence of Operation

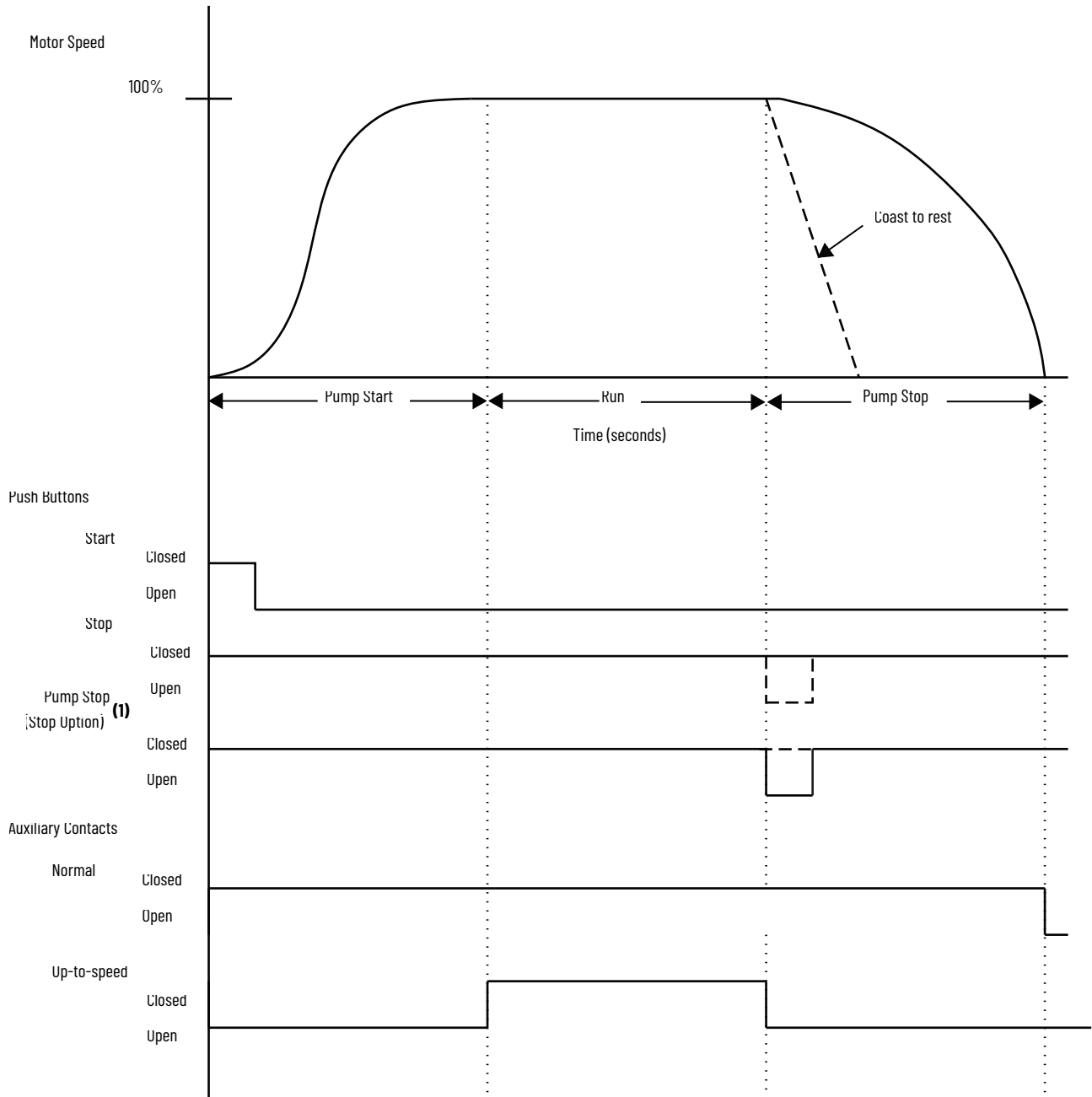

Note Number	Information
1	With the Input push button configured for the Stop Option.

Figure 62 - Smart Motor Braking (SMB) Sequence of Operation

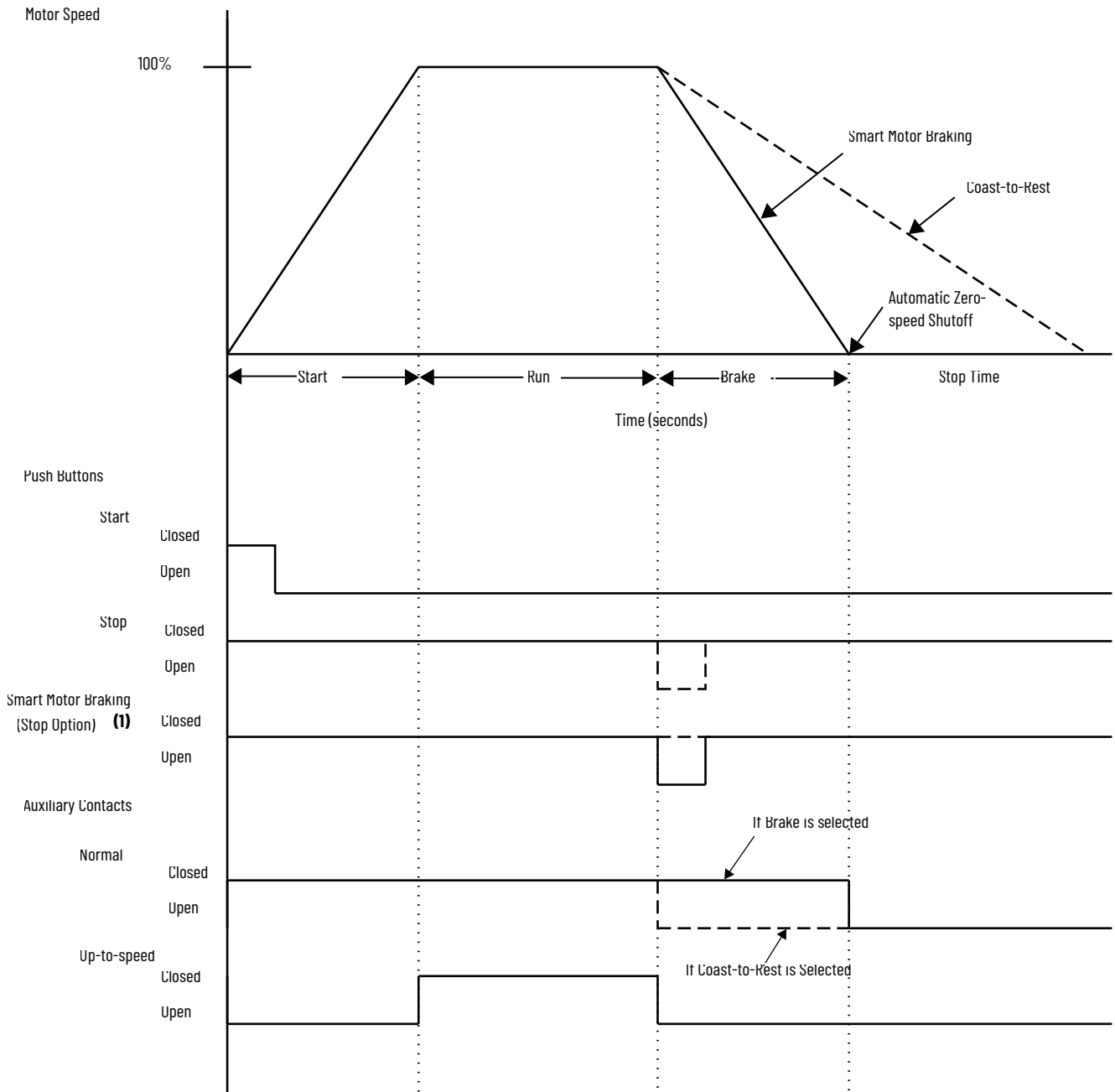

Note Number	Information
1	With the Stop Mode, Parameter 32, configured for SMB and with the Input push button configured for the Stop Option.

Figure 63 - Accu-Stop Sequence of Operation

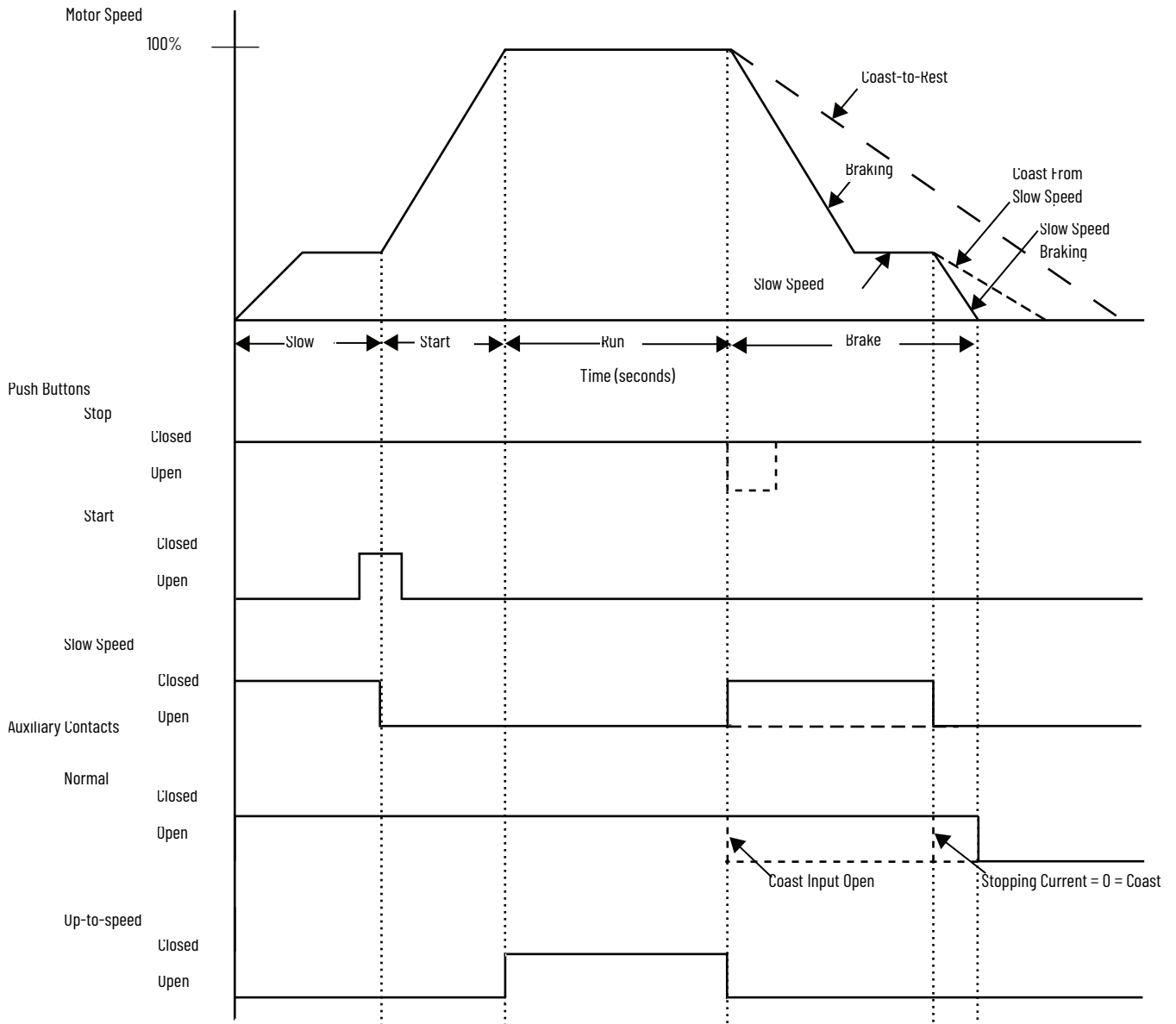
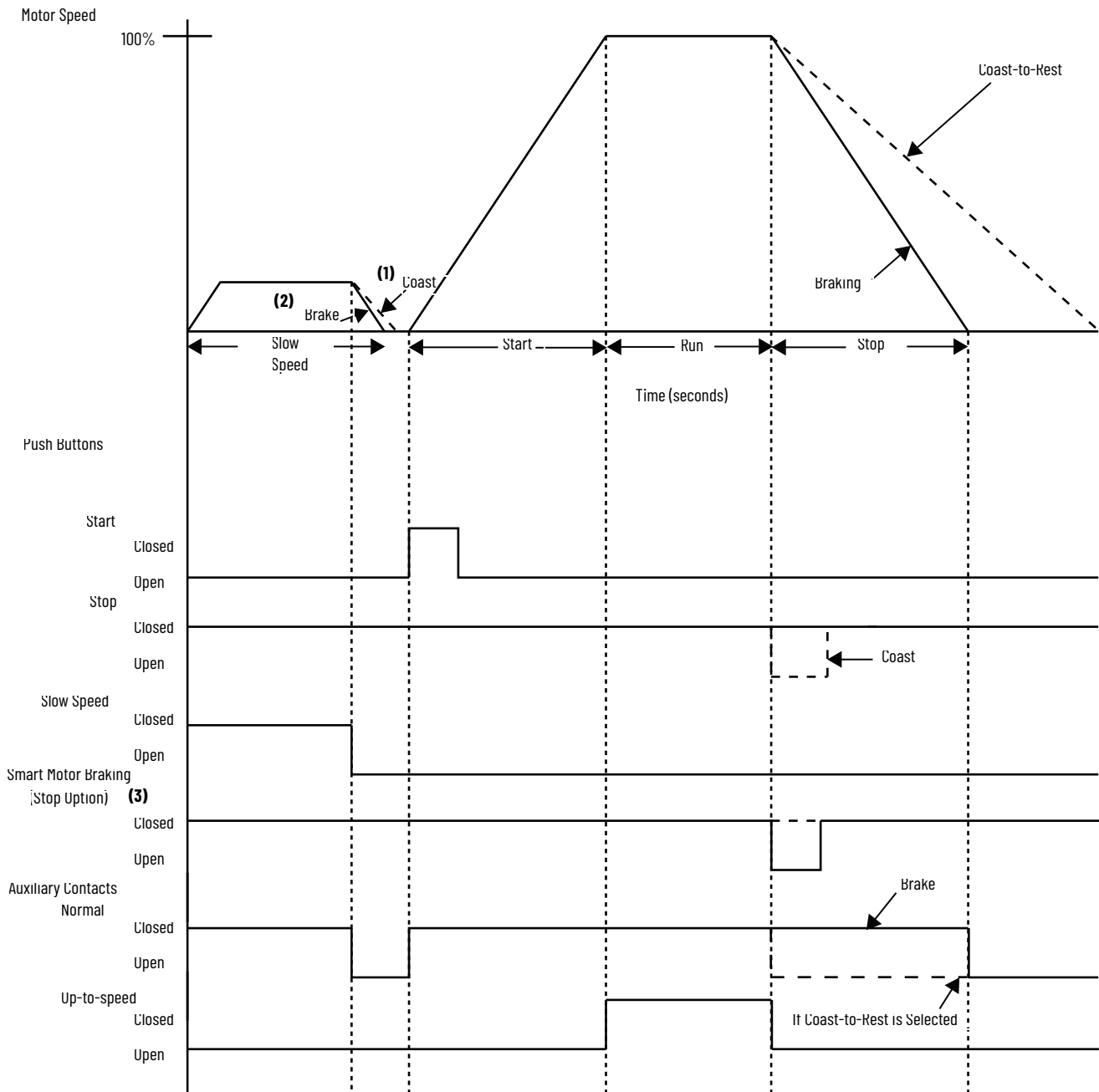

Table 13 - Accu-Stop Parameter Selections

Parameter No.	Parameter Name	Required Setting
32	Stop Mode	Accu-Stop
35	Braking Current	User Value
39	Slow Speed Select	User Value
43	Stopping Current	User Value

Figure 64 - Slow Speed with Braking Sequence of Operation



Note Number	Information
1	Coast if Stopping Current, Parameter 43, = 0 (coast).
2	Brake if Stopping Current, Parameter 43, > 0.
3	With the Stop Mode, Parameter 32, configured for SMB and with the Input push button configured for the Stop Option.

Special Application Considerations

This section covers some considerations that you need to address, depending on your application.

Protective Modules

You should install a protective module (see [Figure 65](#)) containing MOVs (Metal Oxide Varistors) to protect the SMC Flex power components from electrical transients and/or electrical noise.

You can install protective modules controllers rated from 200...600V to protect the power components from electrical transients. The protective modules clip voltage transients that are generated on the lines to prevent such surges from damaging the SCRs. The use of MOVs is highly recommended, because 480V and 600V MOVs offer maximum protection of 1400V and 1600V, respectively.

Figure 65 - Protective Module

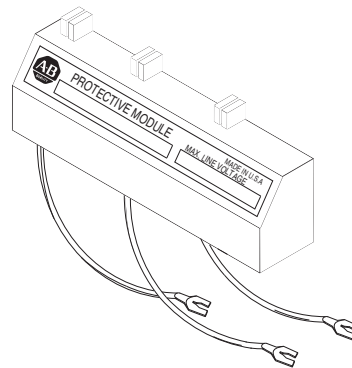

ATTENTION: You can place protective modules on the line, load, or both sides of the SMC Flex controller. However, protective modules must not be placed on the load side of the SMC Flex controller when using inside-the-delta motor connections or with pump, linear speed, or braking control.



ATTENTION: When you install or inspect the protective module, make sure that the controller has been disconnected from the power source. You should inspect the protective module periodically for damage or discoloration. Replace if necessary.

There are two general situations that may occur that could indicate the need for using the protective modules.

1. **Transient Spikes** – Transient spikes will typically occur on the lines feeding the SMC Flex controller or feeding the load from the SMC Flex controller. Transient spikes are created on the line when devices are attached with current-carrying inductances that are open-circuited. The energy stored in the magnetic field is released when the contacts open the circuit. Examples of these include lightly loaded motors, transformers, solenoids, full voltage starters, and electromechanical brakes. Lightning can also cause spikes.
2. **Fast-rising Wavefronts** – If the SMC Flex controller is installed on a system that has fast-rising wavefronts present, although not necessarily high peak voltages, protective modules may be needed. Lightning can also cause this type of response. Additionally, if the controller is on the same bus as other SCR devices (such as AC/DC drives, induction heating equipment, or welding equipment), the firing of the SCRs in those devices can cause noise.

Multi-motor Applications

The SMC Flex controller operates with more than one motor connected to it. Motors should be mechanically coupled. To size the controller, add the total nameplate amperes of all of the connected loads. You should turn off the stall and jam features. Separate overloads are still required to meet the National Electric Code (NEC) requirements.

Figure 66 - Multi-Motor Application

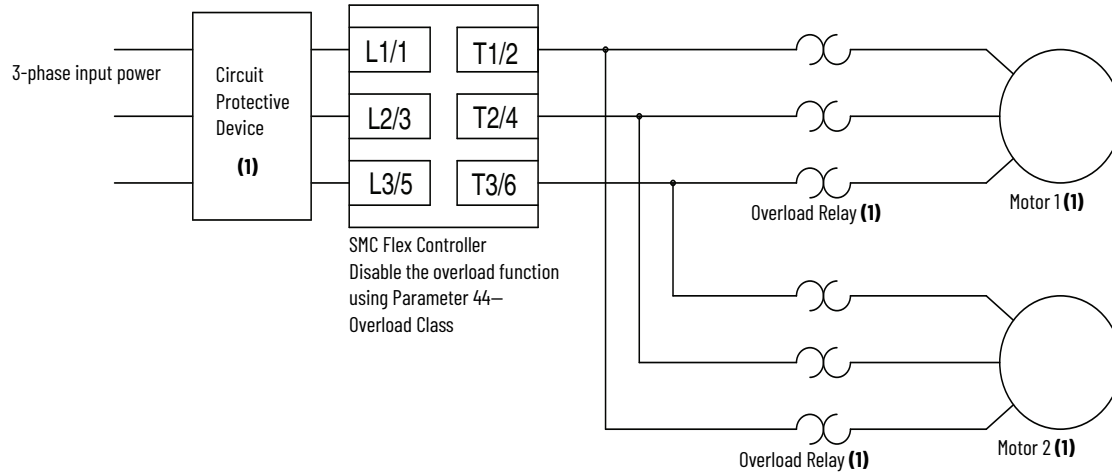

Note Number	Information
1	Customer Supplied

You cannot use the built-in overload protection in multi-motor applications. Disable the SMC Flex Overload function using Parameter 44—Overload Class.

SMC Flex Controller as a Bypass to an AC Drive

By using the controller as shown in [Figure 67](#), a soft start characteristic can be provided if a variable-frequency AC drive (VFD) is non-operational.

- You can achieve a controlled acceleration with this scheme, but speed control is not available in the bypass mode.

Figure 67 - Typical Application Diagram of a Bypass Contactor for an AC Drive

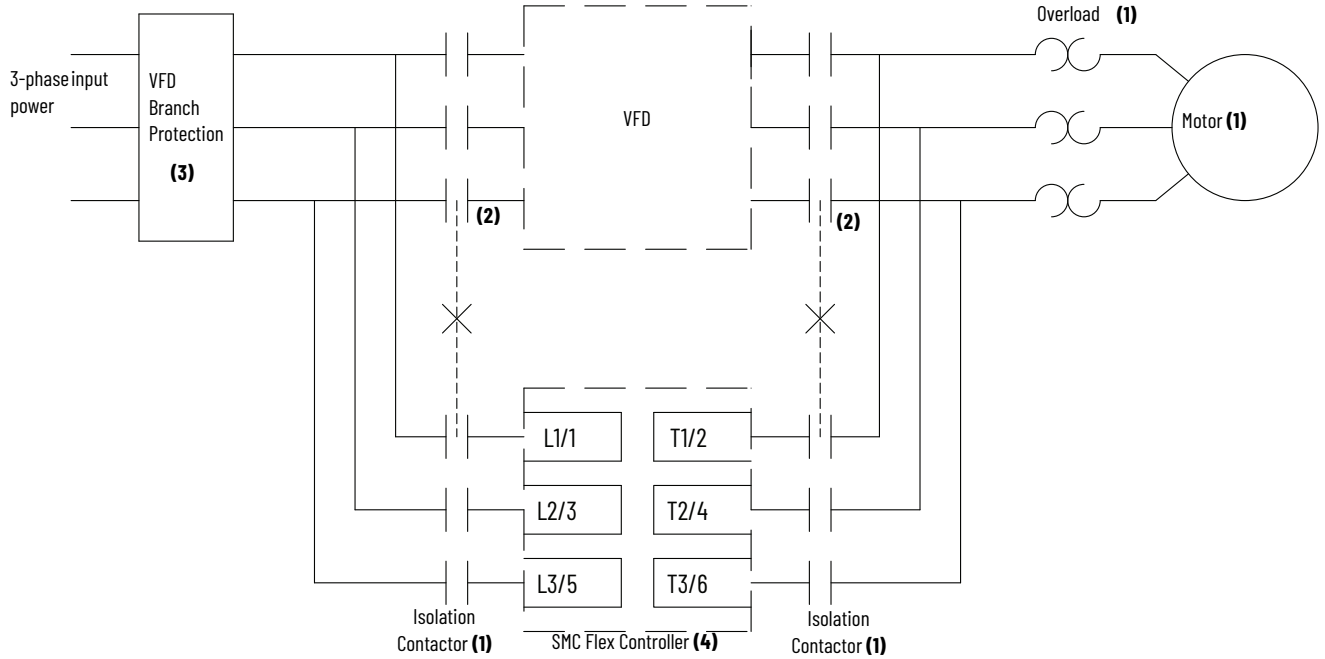

Note Number	Information
1	Customer Supplied
2	Mechanical interlock required.
3	Many VFDs are rated 150% FLA. Because the SMC Flex controller can be used for 600% FLA starting, separate branch circuit protection may be required.
4	Overload protection is included as a standard feature of the SMC Flex controller.

SMC Flex Controller with a Bulletin 1410 Motor Winding Heater

Figure 68 - SMC Flex Controller with Bulletin 1410 Motor Winding Heater

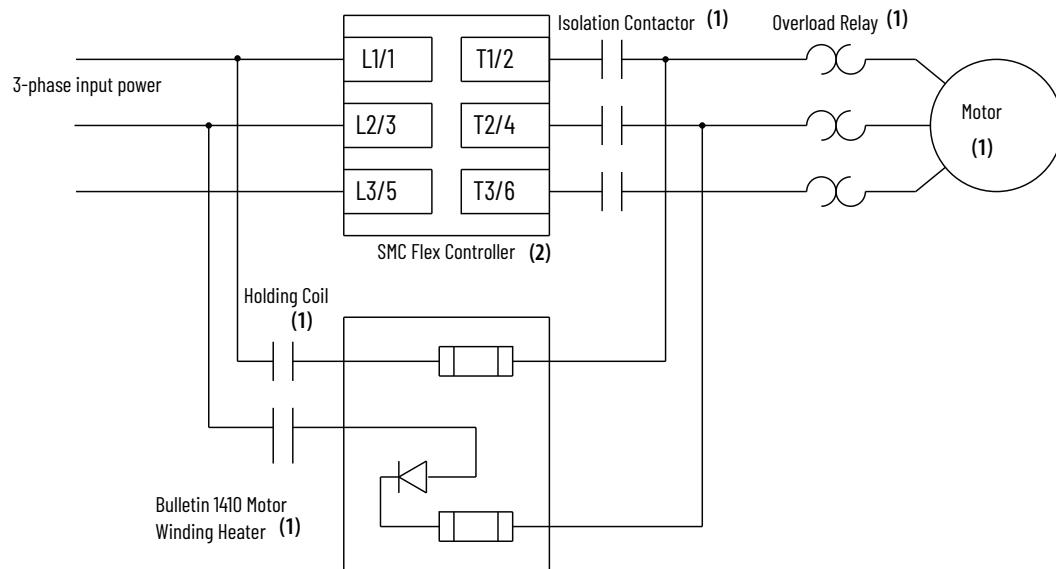

Note Number	Information
1	Customer Supplied
2	Overload protection is included as a standard feature of the SMC Flex controller.

Dual-voltage Wiring

This section explains how to wire a 12-lead, dual-voltage Wye-delta motor using an SMC Flex controller that is programmed for Delta starting.

See your motor manufacturer's wiring diagram for detailed instructions on how to wire the motor. The examples in this section show typical motor connections when you use a 12-lead, dual-voltage Wye-delta motor and the SMC Flex controller.

IMPORTANT The examples in this section show the motor wired for low and high voltage.

[Figure 69](#) shows a typical 6-lead, single-voltage configuration from the perspective of the motor winding connections to the SMC Flex controller power pole. Understanding this wiring helps you to understand how to wire the 12-lead, dual-voltage motor.

Figure 69 - 6-Lead Single-voltage Configuration

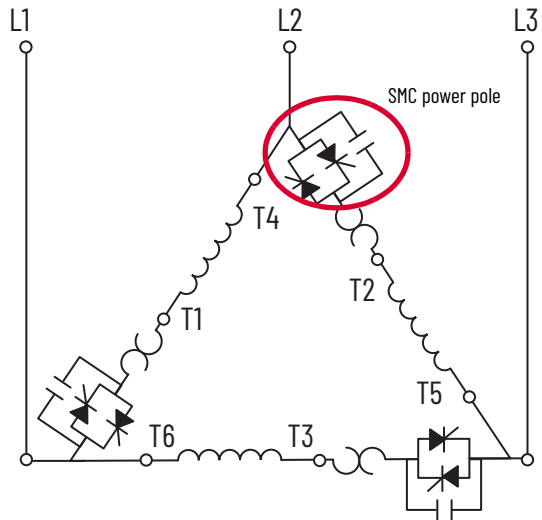
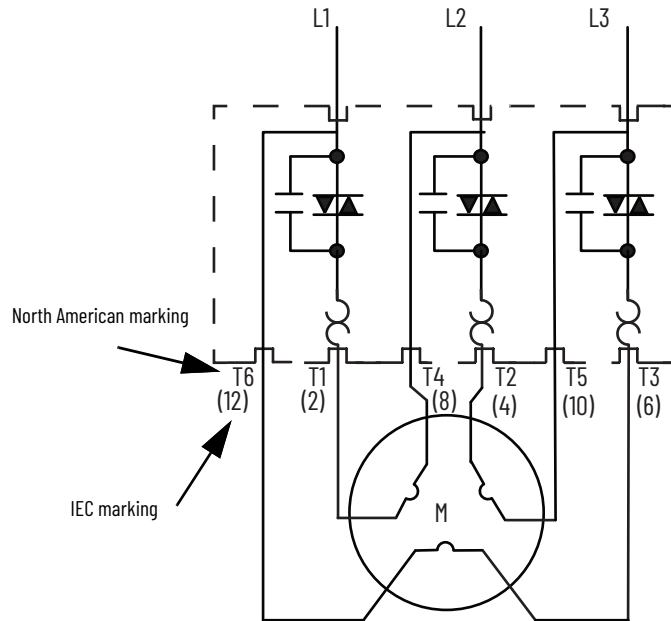

Figure 70 shows the line- and load-side terminal markings of the SMC Flex controller. The controller has global markings. IEC markings are noted in parentheses, while North American markings are preceded with the letter “T”. The explanations in this section refer only to the North American markings that are on the device.

Figure 70 - SMC Flex Controller Terminal Markings



Low-voltage Example

Figure 71 shows three different ways of illustrating the 12-lead connections to run a delta-connected motor for low-voltage operation. Terminal numbers on each drawing refer to the same connection on the device. For example, Terminal T12 on each drawing is the terminal T12 on the same SMC Flex Controller.

Figure 71 - 12-Lead Delta Connection for Low-voltage Run Mode

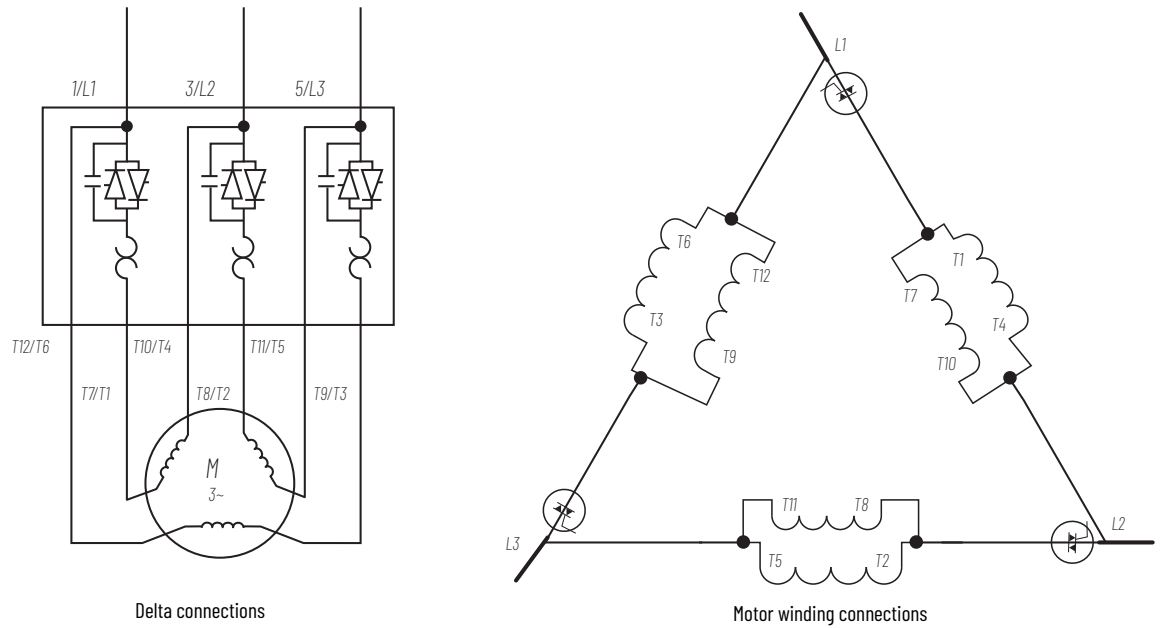

High-voltage Example

Figure 72 shows three different ways of illustrating the 12-lead connections to run a delta-connected motor for high-voltage operation. Terminal numbers on each drawing refer to the same connection on the device. For example, Terminal T12 on each drawing is the terminal T12 on the same SMC Flex Controller.

Figure 72 - 12-Lead Delta Connection for High-voltage Run Mode

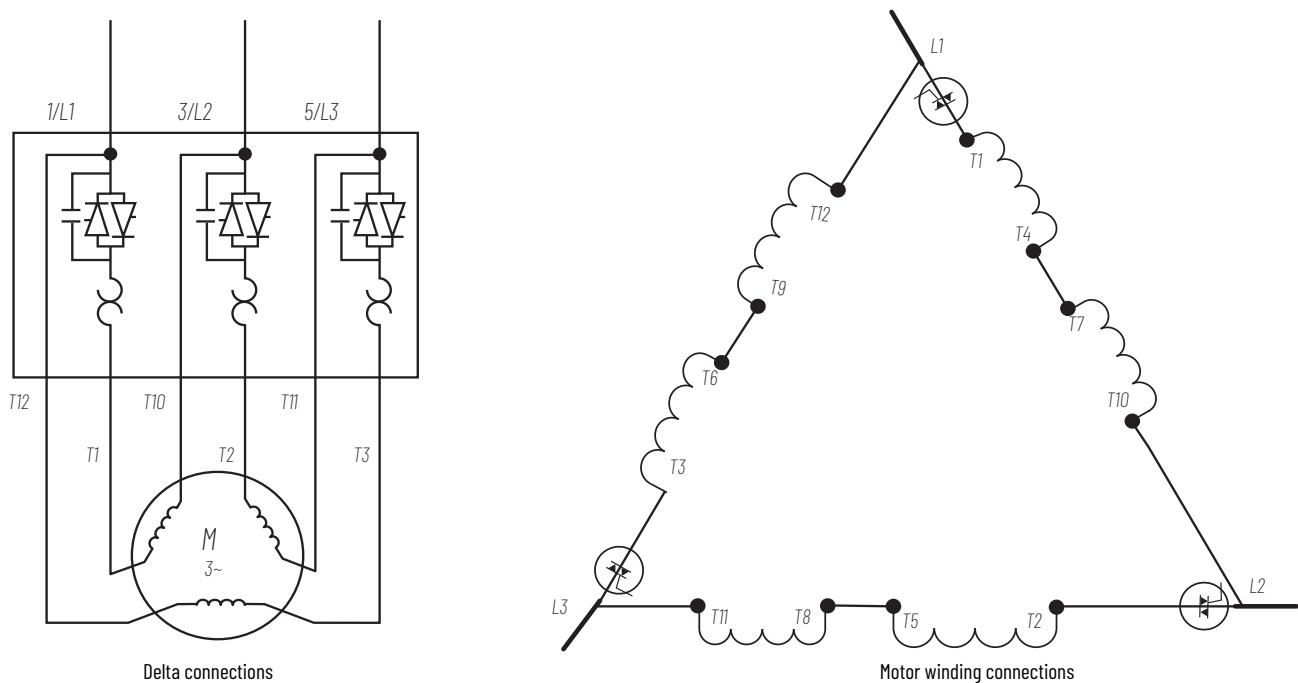

Notes:





Programming

This chapter provides a basic understanding of the built-in programming keypad. This chapter also describes how to program the SMC Flex™ controller by modifying the parameters.

Keypad Description

[Table 14](#) describes the keys that are on the front of the SMC Flex controller.

Table 14 - SMC Flex Controller Keypad

Menu Button	Name	Function
	Escape	Exit a menu, cancel a change to a parameter value, or acknowledge a fault/alarm. Will clear a fault if held for 3 seconds. (Firmware version 6.001 or higher required)
 	Select	Select a digit, select a bit, or enter edit mode in a parameter screen. Will get to menu to change the language being displayed.
	Up/Down Arrows	Scroll through options increase/decrease a value, or toggle a bit.
	Enter	Enter a menu, enter edit mode in a parameter screen, or save a change to a parameter value.

For ease of programming values, after using the Enter key to edit, use the Sel key to jump to the digit that needs to be modified, then use the arrow keys to scroll through the digits.

Programming Menu

Parameters are organized in a three-level menu structure for straightforward programming. [Figure 73](#) details the programming menu structure and the three-level hierarchy.

In order to change parameters, the controller must be in the STOP mode, and the control voltage must be present.

Parameter definitions are listed in Excel® spreadsheets in KnowledgeBase. [Table 15](#) summarizes the information that is in the spreadsheet.



This manual links to SMC Flex Soft Starter Parameters, publication [150-RD001](#); download the spreadsheet now for offline access.

Table 15 - SMC Flex Parameter Categories

Parameter Group	Description
Full Parameter List	Full list of all SMC Flex Controller Parameters
Logic Mask Requirements	Lists the Logic Mask Codes and Binary equivalents
Parameter Special Behavior	Describes codes that can appear under specific conditions and parameter configurations

Figure 73 - Menu Structure Hierarchy

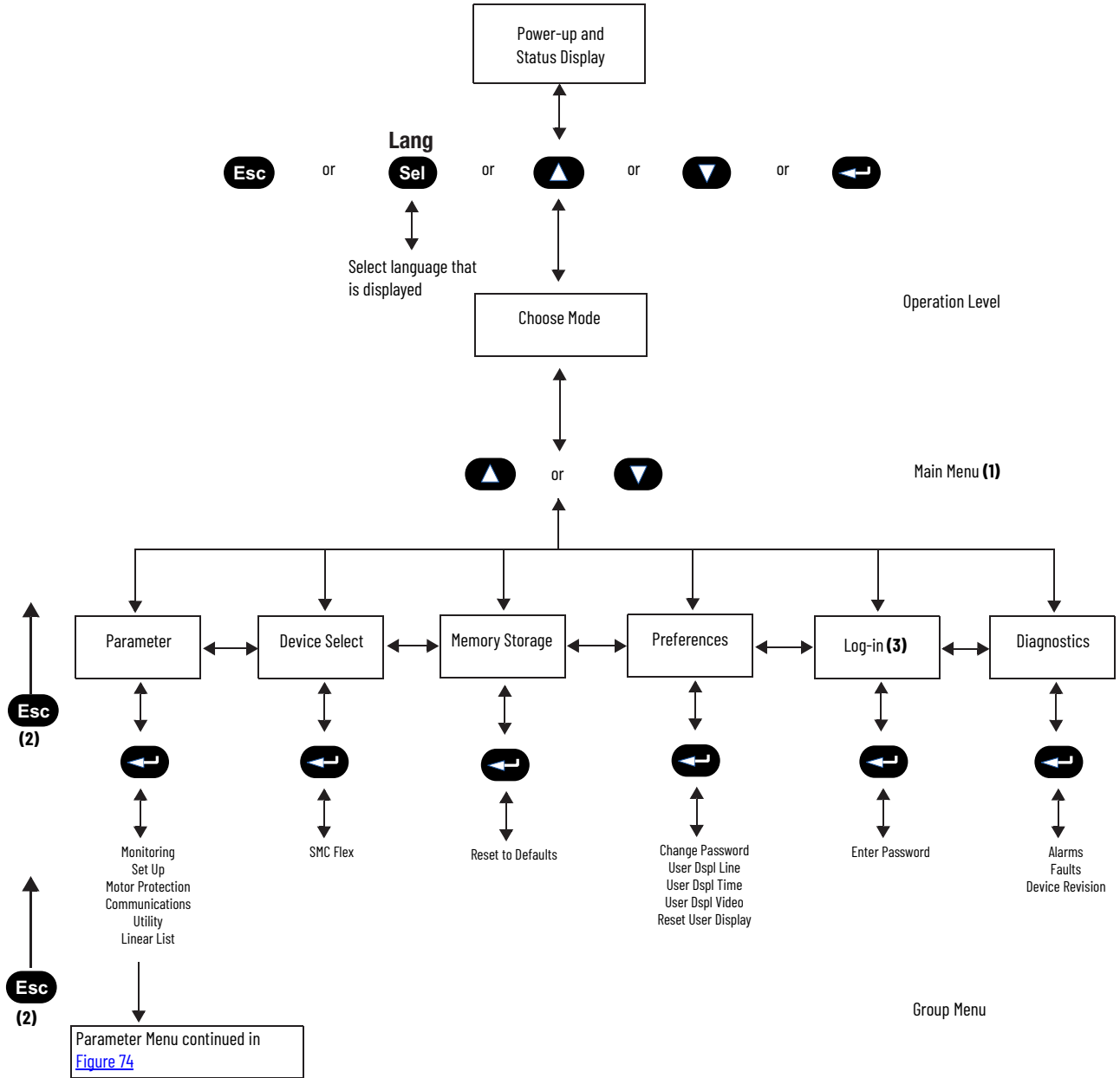

Note	Information
1	The SMC Flex controller does not support EEPROM, Link, Process, or Start-up modes.
2	Steps back one level.
3	Only displayed if a password other than "0" is entered.

Figure 74 - Parameter Menu Structure

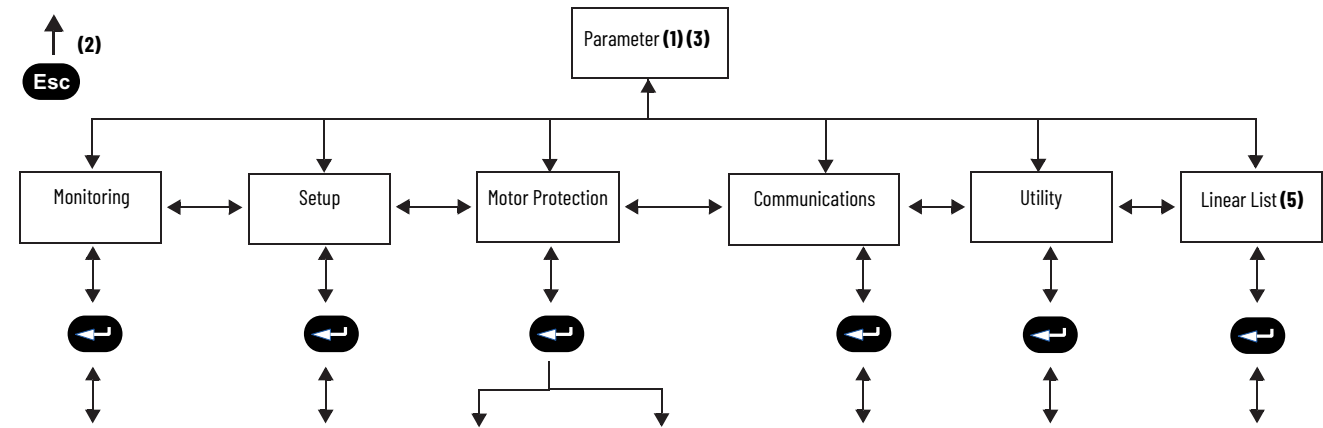

Metering Volts Phase A-B Volts Phase B-C Volts Phase C-A Current Phase A Current Phase B Current Phase C Watt Meter Kilowatt Hours Elapsed Time Meter Reset Power Factor Mtr Therm Usage Motor Speed	Basic SMC Option Motor Connection Line Voltage Starting Mode Ramp Time Initial Torque Cur Limit Lvl Kickstart Time Kickstart Lvl Stop Input Option 1 Input Option 2 Input Stop Mode Stop Time Braking Current Overload Class Service Factor Motor FLC Overload Reset Aux1 Config Aux2 Config Aux3 Config Aux4 Config Backspin Timer Parameter Mgt (4)	Overload Overload Class Service Factor Motor FLC Overload Reset Overload A Lvl Parameter Mgt (4)	Jam Jam F Lvl Jam F Dly Jam A Lvl Jam A Dly Parameter Mgt (4)	Comm Masks Logic Mask Parameter Mgt (4)	Language Language Parameter Mgt (4)	Linear List All parameters Parameter Mgt (4)
	Dual Ramp (Option 2 Input = Dual Ramp) Starting Mode 2 Ramp Time 2 Initial Torque 2 Cur Limit Lvl 2 Kickstart Time 2 Kickstart Lvl 2 Parameter Mgt (4)	Underload Underload F Lvl Underload F Dly Underload A Lvl Underload A Dly Parameter Mgt (4)	Stall Stall Dly Parameter Mgt (4)	DataLinks Data In A1 Data In A2 Data In B1 Data In B2 Data In C1 Data In C2 Data In D1 Data In D2 Data Out A1 Data Out A2 Data Out B1 Data Out B2 Data Out C1 Data Out C2 Data Out D1 Data Out D2 Parameter Mgt (4)	Motor Data MotorFLC Motor ID Parameter Mgt (4)	
	Preset SS (Option 2 Input = Preset SS) Slow Speed Sel Slow Speed Dir Slow Accel Cur Slow Running Cur Parameter Mgt (4)	Undervoltage Undervolt F Lvl Undervolt F Dly Undervolt A Lvl Undervolt A Dly Parameter Mgt (4)	Ground Fault Gnd Flt Enable Gnd Flt Lvl Gnd Flt Dly Gnd Flt Inh Time Gnd Flt A Enable Gnd Flt A Lvl Gnd Flt A Dly Parameter Mgt (4)			
	(Option 2 Input = Accu-Stop) Slow Speed Sel Slow Accel Cur Slow Running Cur Braking Current Stopping Current Parameter Mgt (4)	Overvoltage Overvolt F Lvl Overvolt F Dly Overvolt A Lvl Overvolt A Dly Parameter Mgt (4)	PTC PTC Enable Parameter Mgt (4)			
		Unbalance Unbalance F Lvl Unbalance F Dly Unbalance A Lvl Unbalance A Dly Parameter Mgt (4)	Phase Reversal Phase Reversal Parameter Mgt (4)			
			Restart Starts Per Hour Restart Attempts Restart Dly Parameter Mgt (4)			

Note	Information
1	Depending upon the option that is selected, some parameters may not appear in product display..
2	Steps back one level.
3	For further information about parameters, see KnowledgeBase Article SMC Flex Soft Starter Parameters
4	For further information on parameter management, see page 81 ..
5	See Table 16 for all SMC Flex parameters that are available by the Linear List.

Table 16 - Parameter Linear List

Parameter No.	Description	Parameter No.	Description	Parameter No.	Description	Parameter No.	Description
1	Volts Phase A-B	35	Braking Current	67	Jam F Lvl	101	Data Out C2
2	Volts Phase B-C	36	Braking Time	68	Jam F Dly	102	Data Out D1
3	Volts Phase C-A	37	Load Type	69	Jam A Lvl	103	Data Out D2
4	Current Phase A	38	High Eff Brake	70	Jam A Dly	104	Motor ID
5	Current Phase B	39	Slow Speed Sel	71	Stall Delay	105	CT Ratio
6	Current Phase C	40	Slow Speed Dir	72	Gnd Flt Enable	106	MV Ratio
7	Watt Meter	41	Slow Accel Cur	73	Gnd Flt Level	107	Aux1 Config
8	Kilowatt Hours	42	Slow Running Cur	74	Gnd Flt Delay	108	Aux3 Config
9	Elapsed Time	43	Stopping Current	75	Gnd Flt Inh time	109	Aux4 Config
10	Meter Reset	44	Overload Class	76	Gnd Flt A Enable	110	Aux2 Config
11	Power Factor	45	Service Factor	77	Gnd Flt A Level	111	Language
12	Mtr Therm Usage	46	Motor FLC	78	Gnd Flt A Delay	112	Timed Start
13	Motor Speed	47	Overload Reset	79	PTC Enable	113	I Shut Off Level
14	SMC Option	48	OL Shunt Time	80	Phase Reversal	114	UTS Level
15	Motor Connection	49	OL Trip Enable/ Disable	81	Start Per Hour	115	Parameter Mgmt
16	Line Voltage			82	Restart Attempts	116	Backspin Timer
17	Starting Mode	50	Overload A Lvl	83	Restart Delay	117	VShut Off Level
18	Ramp Time	51	Underload F Lvl	84	Line Fault Disable	118	OL Reset Level
19	Initial Torque	52	Underload F Dly	85	Emergency Run	119	Ambient Temp
20	Cur Limit Start	53	Underload A Lvl	86	Current Loss	120	Notch Position
21	Reserved	54	Underload A Dly	87	Logic Mask	121	Notch Maximum
22	Kickstart Time	55	Undervolt F Lvl	88	Data In A1	122	Start Delay
23	Kickstart Level	56	Undervolt F Dly	89	Data In A2	123	By-pass Delay
24	Option Input 2	57	Undervolt A Lvl	90	Data In B1	124	Fault 1
25	Starting Mode 2	58	Undervolt A Dly	91	Data In B2	125	Fault 2
26	Ramp Time 2	59	Overvolt F Lvl	92	Data In C1	126	Fault 3
27	Initial Torque 2	60	Overvolt F Dly	93	Data In C2	127	Fault 4
28	Cur Limit Level 2	61	Overvolt A Lvl	94	Data In D1	128	Fault 5
29	Reserved	62	Overvolt A Dly	95	Data In D2	129	Ramp Time E
30	Kickstart Time 2	63	Unbalance F Lvl	96	Data Out A1	130	Ramp Time 2E
31	Kickstart Level 2	64	Unbalance F Dly	97	Data Out A2	131	Stop Time E
32	Stop Mode	65	Unbalance A Lvl	98	Data Out B1	132	Option Input 1
33	Stop Time	66	Unbalance A Dly	99	Data Out B2	133	Stop Input
34	Pump Pedestal			100	Data Out C1	134	Elapsed Time 2

Password

The SMC Flex controller lets you limit access to the programming system through password protection. This feature is disabled with a factory-set default of 0. To modify the password, complete the in [Table 17](#). If you lose or forget the password, contact your local Rockwell Automation sales office or Allen-Bradley distributor.

Table 17 - Modify the SMC Flex Controller Password









Description	Action	Display						
—	—	<table border="1"> <tr><td>0.0</td><td>Amps</td></tr> <tr><td>0</td><td>Volt</td></tr> <tr><td>0</td><td>%MTU</td></tr> </table>	0.0	Amps	0	Volt	0	%MTU
0.0	Amps							
0	Volt							
0	%MTU							
1. Press the ESC key to go from the status display to the Main menu.		<table border="1"> <tr><td>Main Menu</td></tr> <tr><td>Preferences</td></tr> <tr><td>Diagnostics</td></tr> </table>	Main Menu	Preferences	Diagnostics			
Main Menu								
Preferences								
Diagnostics								
2. Scroll with the Up/Down keys until the Preferences option is highlighted.		<table border="1"> <tr><td>Main Menu</td></tr> <tr><td>Preferences</td></tr> <tr><td>Diagnostics</td></tr> </table>	Main Menu	Preferences	Diagnostics			
Main Menu								
Preferences								
Diagnostics								

Table 17 - Modify the SMC Flex Controller Password (Continued)

3. Press the Enter key to access the Preferences menu.		Preferences: Change Password User Dspy lines
4. Scroll with the Up/Down keys until the Change Password option is highlighted.		Preferences: Change Password User Dspy lines
5. Press the Enter key.		—
6. Press the Up/Down keys to enter the desired number. If you are modifying the password, make a note of it as displayed. Use the Sel key to highlight a single digit.		Prefs: Password New Code: 83 Verify: 83
7. Verification of the new password is required. Press the Enter key.		—
8. Press the Enter key after you have completed modifying the password. ⁽¹⁾		Preferences: Change Password User Dspy lines

(1) To complete the programming process, re-enter the Main Menu mode to log out. This prevents unauthorized access to the programming system.

Parameter Management

Before you begin programming, it's important to understand how the controller memory is:

- structured within the SMC Flex controller
- used on power-up and during normal operation

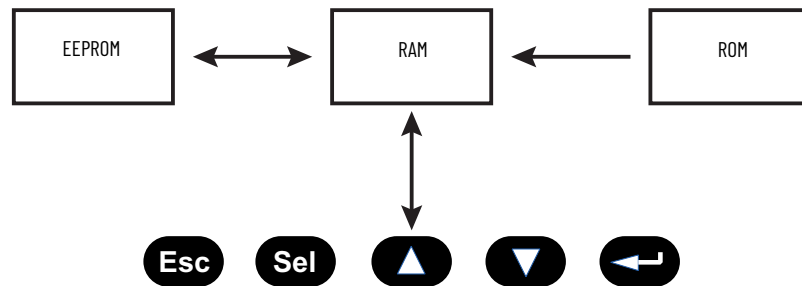
Figure 75 - Memory Block Diagram

Random Access Memory (RAM)

This is the work area of the controller after it is powered up. The SMC Flex controller uses an Auto Store feature when you program parameters. When you modify parameters in the program mode, the new values are stored immediately in RAM and then in EEPROM, once the enter key has been pressed. If control power is lost prior to the enter key being pressed, these values are lost. When the device first powers up, the values from the EEPROM area of memory are copied into RAM.

Read-only Memory (ROM)

The SMC Flex controller comes with factory default parameter values. These settings are stored in non-volatile ROM and are displayed the first time you enter the Program mode. You can restore defaults at any time by accessing the memory storage menu.

Table 18 - Restore Factory Defaults

Command	Description	Action	Display
Restore Defaults	After parameter values have been modified, factory default settings can still be re-initialized.		Memory Storage: Reset to Defaults

Electrically Erasable Programmable Read-only Memory (EEPROM)

The SMC Flex controller provides a non-volatile area for storing user-modified parameter values in the EEPROM.

Parameter Modification

All parameters are modified using the same method. [Table 19](#) lists the basic steps for modifying parameters.

Parameter values modified while the motor is operating are not valid until the next time that operation occurs. If the password is set, you cannot adjust parameters without logging in. Use the Sel key to highlight a single digit.

Table 19 - Modify Parameters

Description	Action	Display ⁽¹⁾						
–	–	<table border="1"> <tr><td>0.0</td><td>Amps</td></tr> <tr><td>0</td><td>Volt</td></tr> <tr><td>0</td><td>%MTU</td></tr> </table>	0.0	Amps	0	Volt	0	%MTU
0.0	Amps							
0	Volt							
0	%MTU							
1. Press the ESC key to go from the status display to the Main menu.		–						
2. Scroll with the Up/Down keys until the Parameter option is highlighted.		<table border="1"> <tr><td>Main Menu</td></tr> <tr><td>Parameter</td></tr> <tr><td>Memory Storage</td></tr> </table>	Main Menu	Parameter	Memory Storage			
Main Menu								
Parameter								
Memory Storage								
3. Press the Enter key to access the Parameter menu.		<table border="1"> <tr><td>F G P : File</td></tr> <tr><td>Monitoring</td></tr> <tr><td>Set Up</td></tr> </table>	F G P : File	Monitoring	Set Up			
F G P : File								
Monitoring								
Set Up								
4. Scroll with the Up/Down keys until the option you want to use (Monitoring, Motor Protection, etc.) is highlighted. For this example, Set Up will be used.		<table border="1"> <tr><td>F G P : File</td></tr> <tr><td>Set Up</td></tr> <tr><td>Motor Protection</td></tr> </table>	F G P : File	Set Up	Motor Protection			
F G P : File								
Set Up								
Motor Protection								
5. Press Enter to select the Set Up group.		–						
6. Scroll to Basic Set Up and press Enter. ⁽²⁾		<table border="1"> <tr><td>F G P : Group</td></tr> <tr><td>Basic Set Up</td></tr> </table>	F G P : Group	Basic Set Up				
F G P : Group								
Basic Set Up								
7. Scroll to the Starting Mode parameter by using the Up/Down keys, and press Enter.		<table border="1"> <tr><td>F G P : Parameter</td></tr> <tr><td>Starting Mode</td></tr> <tr><td>Ramp Time</td></tr> </table>	F G P : Parameter	Starting Mode	Ramp Time			
F G P : Parameter								
Starting Mode								
Ramp Time								
8. Press Enter to select the option. Scroll to the option of your choice by using the Up/Down keys. For this example, we will choose Current Limit.		<table border="1"> <tr><td>F G P : P# 17</td></tr> <tr><td>Starting Mode</td></tr> <tr><td>Current Lim</td></tr> </table>	F G P : P# 17	Starting Mode	Current Lim			
F G P : P# 17								
Starting Mode								
Current Lim								
9. Press the Enter key to accept the new setting.		–						
10. Scroll to the next parameter by using the Down key. Continue the process until all desired settings are entered.		<table border="1"> <tr><td>F G P : P# 18</td></tr> <tr><td>Ramp Time</td></tr> <tr><td>10 Secs</td></tr> </table>	F G P : P# 18	Ramp Time	10 Secs			
F G P : P# 18								
Ramp Time								
10 Secs								

(1) The display indicates that the second line is now active by highlighting the first character. If the LCD display does not provide a highlighted cursor, then the controller is in the Display mode.

(2) The SMC Option advises you if any control option (such as Pump Control) is resident. This parameter is factory set and you cannot modify it.

Soft Start

Use the parameters that are listed in [Table 20](#) to adjust the voltage ramp supplied to the motor.

Table 20 - Soft Start (Voltage Ramp) Parameters

Parameter No.	Parameter Name	Description	Value
17	Starting Mode	This must be programmed for Soft Start.	Soft Start
18	Ramp Time ⁽¹⁾	This programs the time period that the controller will ramp the output voltage up to full voltage from the Initial Torque level programmed.	0...30 s
19	Initial Torque	The initial reduced output voltage level for the voltage ramp to the motor is established and adjusted with this parameter.	0...90% locked rotor torque
22	Kickstart Time	A boost of current is provided to the motor for the programmed time period.	0.0...2.0 s
23	Kickstart Level	Adjusts the amount of current applied to the motor during the kickstart time.	0...90% locked rotor torque

(1) If the controller senses that the motor has reached full speed before it completes the Soft Start, it automatically switches to providing full voltage to the motor.

Current Limit Start

Use the parameters that are listed in [Table 21](#) apply a current limit start to the motor.

Table 21 - Current Limit Start Parameters

Parameter No.	Parameter Name	Description	Value
17	Starting Mode	This must be programmed for Current Limit.	Current Limit
18	Ramp Time ⁽¹⁾	This programs the time period that the controller will ramp the output voltage up to full voltage from the Initial Torque level programmed.	0...30 s
20	Current Limit Level	This parameter provides adjustability for the reduced output voltage level provided to the motor.	50...600% full load current
22	Kickstart Time	A boost of current is provided to the motor for the programmed time period.	0.0...2.0 s
23	Kickstart Level	Adjusts the amount of current applied to the motor during the kickstart time.	0...90% locked rotor torque

(1) If the controller senses that the motor has reached full speed before it completes the Current Limit Start, it automatically switches to providing full voltage to the motor.

Dual Ramp Start

The SMC Flex controller lets you select between two Start profiles. The parameters that are listed in [Table 22](#) are available in the Set Up menu. Ramp #1 parameters are in the "Basic Setup" menu. Ramp #2 parameters are in the "Dual Ramp" menu. Option Input 2 must be set to "Dual Ramp" to enable the second ramp parameters.

The Ramp #2 parameters will be used if Option Input 2 is active at the time of the start. To obtain Dual Ramp control, Ramp #1 is located in the Setup menu Basic section and Ramp #2 is located in the Option Input 2 (Dual Ramp).

Table 22 - Dual Ramp Start Parameters

Parameter No.	Parameter Name	Description	Value
24	Option Input 2 (Dual Ramp) ⁽¹⁾	"Option input 2" must be set to "Dual Ramp" to enable the dual ramp feature.	—
17	Start Mode ⁽²⁾	Selects the start mode for option #1.	—
18	Ramp Time	Programs the time period during which the controller will ramp the output voltage up to full voltage for the first Soft Start setup.	0...30 s
19	Initial Torque	Lets you adjust the initial torque level applied to the motor at the beginning of the start maneuver for the first Soft Start setup.	0...90% locked rotor torque
20	Current Limit	Lets you adjust the current level applied to the motor during the start maneuver.	50...600% FLC
25	Start Mode 2 ⁽²⁾	Selects the start mode for option #2.	—
26	Ramp Time 2	Programs the time period during which the controller will ramp the output voltage up to full voltage for the second Soft Start setup.	0...30 s
27	Initial Torque 2	Lets you adjust the initial torque level applied to the motor at the beginning of the start maneuver for the second Soft Start setup.	0...90% locked rotor torque
28	Current Limit 2	Lets you adjust the current level applied to the motor during the start maneuver for option #2.	50...600% FLC

(1) The Dual Ramp feature is available on the standard controller.

(2) You can program Kickstart for both start modes.

Full Voltage Start

You can program the SMC Flex controller to provide a full-voltage start (output voltage to the motor reaches full voltage within 1/4 second) with the parameters that are listed in [Table 23](#).

Table 23 - Full-voltage Start Parameters

Parameter No.	Parameter Name	Description	Value
17	Starting Mode	This must be programmed for Full Voltage.	Full Voltage

Linear Speed

The SMC Flex controller lets you control the motor speed during starting and stopping maneuvers. A tachometer input is required. See [page 10](#).

Table 24 - Linear Speed Acceleration and Deceleration Parameters

Parameter No.	Parameter Name	Description	Value
17	Starting Mode	This must be programmed for Linear Speed.	Linear Speed
18	Ramp Time	This programs the time period that the controller will ramp from 0 speed to full speed.	0...30 s
22	Kickstart Time	A boost of current is provided to the motor for the programmed time period.	0.0...2.0 s
23	Kickstart Level	Adjusts the amount of current applied to the motor during the kickstart time.	0...90% locked rotor torque

Programming Parameters

[Table 25](#) lists the option-specific parameters that correlate to each control option. These parameters are in addition to those already discussed in the Basic Set Up and Metering groups.

Table 25 - Option-specific Programming Parameters

Option	Parameter No.	Parameter Name	Description	Value
Standard				
Soft Stop	14	SMC Option	Identifies the type of control present and is not user programmable.	Standard
	33	Stop Time	Lets you set the time period for the soft stopping function.	0...120 s
Preset Slow Speed	14	SMC Option	Identifies the type of control present and is not user programmable.	Standard
	39	Slow Speed Select	Lets you program the slow speed that best fits the application.	Low: 7% - forward, 10% - reverse High: 15% - forward, 20% - reverse
	40	Slow Speed Direction	Programs the slow speed motor rotational direction.	Forward, Reverse
	41	Slow Accel Current	Lets you program the required current to accelerate the motor to slow speed operation.	0...450% FLA
	42	Slow Running Current	Lets you program the required current to operate the motor at the slow speed setting.	0...450% FLA
Pump Control				
Pump Control	14	SMC Option	Identifies the type of control present and is not user programmable.	Pump Control
	33	Stop Time	Lets you set the time period for the pump stopping function.	0...120 s
	17	Starting Mode	Lets you program the SMC Flex controller for the type of starting that best fits the application.	Pump Start, Soft Start, Current Limit Start
Braking Control				
SMB Smart Motor Braking	14	SMC Option	Identifies the type of control present and is not user programmable.	Braking Control
	35	Braking Current ⁽¹⁾	Lets you program the intensity of the braking current applied to the motor.	0...400% FLA
Accu-Stop	14	SMC Option	Identifies the type of control present and is not user programmable.	Braking Control
	39	Slow Speed Select	Lets you program the slow speed that best fits the application.	Low: 7% High: 15%
	41	Slow Accel Current	Lets you program the required current to accelerate the motor to slow speed operation.	0...450% FLA
	42	Slow Running Current	Lets you program the required current to operate the motor at the slow speed setting.	0...450% FLA
	35	Braking Current ⁽¹⁾	Lets you program the intensity of the braking current applied to the motor.	0...400% FLA
	43	Stopping Current ⁽¹⁾	Lets you program the intensity of the braking current applied to the motor from slow speed operation.	0...400% FLA
Slow Speed with Braking	14	SMC Option	Identifies the type of control present and is not user programmable.	Braking Control
	39	Slow Speed Select	Lets you program the slow speed that best fits the application.	Low: 7% High: 15%
	41	Slow Accel Current	Lets you program the required current to accelerate the motor to slow speed operation.	0...450% FLA
	42	Slow Running Current	Lets you program the required current to operate the motor at the slow speed setting.	0...450% FLA
	35	Braking Current ⁽¹⁾	Lets you program the intensity of the braking current applied to the motor.	0...400% FLA

(1) All braking/stopping current settings in the range of 1...100% provide 100% braking current to the motor.

Basic Setup

The Basic Setup programming group provides a limited parameter set, allowing quick startup with minimal adjustment. If you plan to implement some of the advanced features (such as Dual Ramp or Preset Slow Speed), select the Setup programming group. It provides the complete Basic Setup parameter set and the advanced set.

Table 26 - Basic Setup Parameters

Parameter No.	Parameter Name	Description	Value
14	SMC Option	Displays the type of controller. This is factory set and not adjustable.	Standard
15	Motor Connection	Displays the motor type to which the device is being connected.	Line or Delta
16	Line Voltage	Displays the system line voltage to which the unit is connected.	
17	Starting Mode	Lets you program the SMC Flex controller for the type of starting that best fits the application.	Soft Start, Current Limit, Full Voltage, Linear Speed
18	Ramp Time	Sets the time period during which the controller will ramp the output voltage.	0...30 s
19	Initial Torque ⁽¹⁾	Establishes and adjusts the initial reduced voltage output level for the voltage ramp.	0...90% of locked rotor torque
20	Current Limit Level ⁽²⁾	The current limit level that is applied for the Ramp Time selected.	50...600% FLA
22	Kickstart Time	A boost current is provided to the motor for the programmed time period.	0.0...2.0 s
23	Kickstart Level	Adjusts the amount of current applied to the motor during kickstart.	0...90% of locked rotor torque
133	Stop Input	Lets you select the operation of terminal 18, Stop Input.	Coast, Stop Option
132	Option Input 1	Lets you select the operation of terminal 16, Option Input #1.	Disable, Coast, Stop Option, Fault, Fault NC, Network
24	Option Input 2	Lets you select the operation of terminal 15, Option Input #2.	Disable, Slow Speed, Dual Ramp, Fault, Fault NC, Network, Clear Fault
32	Stop Mode	Lets you program the SMC Flex controller for the type of stopping that best fits the application.	Disable, Soft Stop, Linear Speed
33	Stop Time	Sets the time period during which the controller will ramp the voltage during a stopping maneuver.	0.0...120 s
44	Overload Class	Lets you select the Overload Trip Class.	Disable, 10, 15, 20, 30
45	Service Factor	Lets you program the service factor from the motor nameplate.	0.01...1.99
46	Motor FLC	Lets you program the FLC from the motor nameplate.	1.0...2200
47	OL Reset	Lets you select the type of overload reset.	Auto, Manual
107	Aux1 Config	Lets you configure the operation of the contacts that is located at terminals 19 and 20. Contact is provided as standard with the SMC Flex controller.	Normal, Up-to-speed, Fault, Alarm, Network Control, External Bypass: (N.O.)
110	Aux2 Config	Lets you configure the operation of the contacts that is located at terminals 29 and 30. Contact is provided as standard with the SMC Flex controller.	Normal, Up-to-speed, Fault, Alarm, Network Control, External Bypass: (N.O.)
108	Aux3 Config	Lets you configure the operation of the contacts that is located at terminals 31 and 32. Contact is provided as standard with the SMC Flex controller.	Normal, Up-to-speed, Fault, Alarm, Network Control, External Bypass: (N.O.)
109	Aux4 Config	Lets you configure the operation of the contacts that is located at terminals 33 and 34. Contact is provided as standard with the SMC Flex controller.	Normal, Up-to-speed, Fault, Alarm, Network Control, External Bypass: (N.O.)
115	Parameter Mgmt	Recall of factory default parameter values.	Ready, Load Default

(1) Starting Mode must be programmed to Soft Start to obtain access to the Initial Torque parameter.

(2) Starting Mode must be programmed to Current Limit to obtain access to the Current Limit Level parameter.

Motor Protection

While the Basic Setup group lets you get started with a minimum number of parameters to modify, the Motor Protection group allows full access to the SMC Flex controller parameter set. [Table 27](#) lists the additional setup parameters that are provided in this group.

The majority of parameters have a Fault and an Alarm setting.



ATTENTION: For overload protection, you must enter the data as it appears on the motor nameplate.

Table 27 - Motor Protection Parameters

Protection Type	Description	Setup Parameters			
		No.	Parameter Name	No.	Parameter Name
Overload	Lets you select the operation of the overload:	44	Overload Class,	48	OL Shunt Time
		45	Service Factor	49	OL Trip Enable/Disable
		46	Motor FLC	50	Overload A Lvl
		47	Overload Reset		
Underload ⁽¹⁾	Determines the trip level as a percentage of the motor's FLA, and the delay period.	51	Underload Fault Level	53	Underload Alarm Level
		52	Underload Fault Delay	54	Underload Alarm Delay
Undervoltage ⁽²⁾	Determines the trip level as a percentage of the line voltage and the delay period.	55	Undervoltage Fault Level	57	Undervoltage Alarm Level
		56	Undervoltage Fault Delay	58	Undervoltage Alarm Delay
Overvoltage ⁽²⁾	Determines the trip level as a percentage of line voltage and delay period.	59	Overvoltage Fault Level	61	Overvoltage Alarm Level
		60	Overvoltage Fault Delay	62	Overvoltage Alarm Delay
Unbalance ⁽²⁾	Lets you set the voltage unbalance trip level and delay period.	63	Unbalance Fault Level	65	Unbalance Alarm Level
		64	Unbalance Fault Delay	66	Unbalance Alarm Delay
Jam ⁽¹⁾	Determines the trip level as a percentage of motor full load current and delay period.	67	Jam Fault Level	69	Jam Alarm Level
		68	Jam Fault Delay	70	Jam Alarm Delay
Stall	Lets you set the stall delay time.	71	Stall Delay		
Ground Fault ⁽³⁾	Lets you enable the ground fault level in amps, delay time, and inhibit time.	72	Ground Fault Enable	76	Ground Fault Alarm Enable
		73	Ground Fault Level	77	Ground Fault Alarm Level
		74	Ground Fault Delay	78	Ground Fault Alarm Delay
		75	Ground Fault Inhibit Time		
Motor PTC ⁽⁴⁾	Lets you connect a PTC to the SMC and enable a fault when it becomes active.	79	PTC Enable		
Phase Reversal	Determines the proper orientation of line connections to the SMC. If Enabled and phases are out of sequence, a fault will be indicated.	80	Phase Reversal		
Restarts	Lets you determine the maximum number of restarts per hour the unit can experience, and delay time between consecutive starts.	81	Starts Per Hour	83	Restart Delay
		82	Restart Attempts		

(1) For Jam and Underload detection to function, the Motor FLC must be programmed in the Motor Protection group. See [Chapter 5](#).

(2) The delay time must be set to a value greater than zero when Undervoltage, Overvoltage, and Unbalance are enabled.

(3) See [page 21](#).

(4) See [page 22](#).

Table 28 - Example Settings

Protection Type	Parameter No.	Parameter Name	Setting Value	Trip Value
Undervoltage ⁽¹⁾	16	Line Voltage	480V	384V
	55	Undervoltage level	80%	
Overvoltage ⁽¹⁾	16	Line Voltage	240V	276V
	59	Overvoltage level	115%	
Jam ⁽²⁾⁽³⁾	46	Motor FLC	150 A	600 A
	67	Jam level	400%	
Underload ⁽²⁾	46	Motor FLC	90 A	54 A
	51	Underload level	60%	

(1) The average value of the three phase-to-phase voltages is utilized.

(2) The largest value of the three-phase currents is utilized.

(3) The SMC Flex controller self protects.









Metering

While the SMC Flex™ controller operates your motor, it also monitors several different parameters, providing a full-function metering^(a) package.

View Metering Data





To access the metering information, follow the procedure in [Table 29](#).

Table 29 - Access the Metering Information

Description	Action	Display						
—	—	<table border="1"> <tr><td>###</td><td>Amps</td></tr> <tr><td>###</td><td>Volt</td></tr> <tr><td>##</td><td>%MTU</td></tr> </table>	###	Amps	###	Volt	##	%MTU
###	Amps							
###	Volt							
##	%MTU							
1. Press any of the following keys to access the Main Menu.	   	<table border="1"> <tr><td>Main Menu</td></tr> <tr><td>Parameter</td></tr> <tr><td>Memory Storage</td></tr> </table>	Main Menu	Parameter	Memory Storage			
Main Menu								
Parameter								
Memory Storage								
2. Scroll with the Up/Down keys until the Parameter option is shown.	 	<table border="1"> <tr><td>Main Menu</td></tr> <tr><td>Parameter</td></tr> <tr><td>Memory Storage</td></tr> </table>	Main Menu	Parameter	Memory Storage			
Main Menu								
Parameter								
Memory Storage								
3. Press the Enter key to select the Parameter option.		—						
4. Scroll with the Up/Down keys until the Monitoring option is displayed.	 	<table border="1"> <tr><td>F G P :</td><td>File</td></tr> <tr><td>Monitoring</td></tr> <tr><td>Set Up</td></tr> </table>	F G P :	File	Monitoring	Set Up		
F G P :	File							
Monitoring								
Set Up								

(a) See [page 24](#) or [Figure 74](#) for details on the metering functions.

Table 29 - Access the Metering Information (Continued)

Description	Action	Display																																																																																																												
5. Press the Enter key to access the Monitoring group.		-																																																																																																												
6. Press the Enter key to access the Metering group.		<table border="1" style="width: 100%; border-collapse: collapse;"> <tr> <td style="width: 60%;">F G P :</td> <td style="width: 20%;">Group</td> <td style="width: 20%;"></td> </tr> <tr> <td>Metering</td> <td></td> <td></td> </tr> </table>	F G P :	Group		Metering																																																																																																								
F G P :	Group																																																																																																													
Metering																																																																																																														
7. Scroll through the Metering parameters with the Up/Down keys to access the desired information. Press the Enter key to view that parameter.	  	<table border="1" style="width: 100%; border-collapse: collapse;"> <tr> <td style="width: 60%;">F G P :</td> <td style="width: 20%;">P# 1</td> <td style="width: 20%;"></td> </tr> <tr> <td>Volts Phase A-B</td> <td></td> <td></td> </tr> <tr> <td>###</td> <td>Volt</td> <td></td> </tr> <tr> <td>F G P :</td> <td>P# 2</td> <td></td> </tr> <tr> <td>Volts Phase B-C</td> <td></td> <td></td> </tr> <tr> <td>###</td> <td>Volt</td> <td></td> </tr> <tr> <td>F G P :</td> <td>P# 3</td> <td></td> </tr> <tr> <td>Volts Phase C-A</td> <td></td> <td></td> </tr> <tr> <td>###</td> <td>Volt</td> <td></td> </tr> <tr> <td>F G P :</td> <td>P# 4</td> <td></td> </tr> <tr> <td>Current Phase A</td> <td></td> <td></td> </tr> <tr> <td>##.#</td> <td>Amps</td> <td></td> </tr> <tr> <td>F G P :</td> <td>P# 5</td> <td></td> </tr> <tr> <td>Current Phase B</td> <td></td> <td></td> </tr> <tr> <td>##.#</td> <td>Amps</td> <td></td> </tr> <tr> <td>F G P :</td> <td>P# 6</td> <td></td> </tr> <tr> <td>Current Phase C</td> <td></td> <td></td> </tr> <tr> <td>##.#</td> <td>Amps</td> <td></td> </tr> <tr> <td>F G P :</td> <td>P# 7</td> <td></td> </tr> <tr> <td>Watt Meter</td> <td></td> <td></td> </tr> <tr> <td>##.#</td> <td>KW</td> <td></td> </tr> <tr> <td>F G P :</td> <td>P# 8</td> <td></td> </tr> <tr> <td>Kilowatt Hours</td> <td></td> <td></td> </tr> <tr> <td>##.#</td> <td>KWH</td> <td></td> </tr> <tr> <td>F G P :</td> <td>P# 9</td> <td></td> </tr> <tr> <td>Elapsed Time</td> <td></td> <td></td> </tr> <tr> <td>##.#</td> <td>Hour</td> <td></td> </tr> <tr> <td>F G P :</td> <td>P# 10</td> <td></td> </tr> <tr> <td>Meter Reset</td> <td></td> <td></td> </tr> <tr> <td>No</td> <td></td> <td></td> </tr> <tr> <td>F G P :</td> <td>P# 11</td> <td></td> </tr> <tr> <td>Power Factor</td> <td></td> <td></td> </tr> <tr> <td>##.#</td> <td></td> <td></td> </tr> <tr> <td>F G P :</td> <td>P# 12</td> <td></td> </tr> <tr> <td>Mtr Therm Usage</td> <td></td> <td></td> </tr> <tr> <td>##</td> <td>%MTU</td> <td></td> </tr> </table>	F G P :	P# 1		Volts Phase A-B			###	Volt		F G P :	P# 2		Volts Phase B-C			###	Volt		F G P :	P# 3		Volts Phase C-A			###	Volt		F G P :	P# 4		Current Phase A			##.#	Amps		F G P :	P# 5		Current Phase B			##.#	Amps		F G P :	P# 6		Current Phase C			##.#	Amps		F G P :	P# 7		Watt Meter			##.#	KW		F G P :	P# 8		Kilowatt Hours			##.#	KWH		F G P :	P# 9		Elapsed Time			##.#	Hour		F G P :	P# 10		Meter Reset			No			F G P :	P# 11		Power Factor			##.#			F G P :	P# 12		Mtr Therm Usage			##	%MTU	
F G P :	P# 1																																																																																																													
Volts Phase A-B																																																																																																														
###	Volt																																																																																																													
F G P :	P# 2																																																																																																													
Volts Phase B-C																																																																																																														
###	Volt																																																																																																													
F G P :	P# 3																																																																																																													
Volts Phase C-A																																																																																																														
###	Volt																																																																																																													
F G P :	P# 4																																																																																																													
Current Phase A																																																																																																														
##.#	Amps																																																																																																													
F G P :	P# 5																																																																																																													
Current Phase B																																																																																																														
##.#	Amps																																																																																																													
F G P :	P# 6																																																																																																													
Current Phase C																																																																																																														
##.#	Amps																																																																																																													
F G P :	P# 7																																																																																																													
Watt Meter																																																																																																														
##.#	KW																																																																																																													
F G P :	P# 8																																																																																																													
Kilowatt Hours																																																																																																														
##.#	KWH																																																																																																													
F G P :	P# 9																																																																																																													
Elapsed Time																																																																																																														
##.#	Hour																																																																																																													
F G P :	P# 10																																																																																																													
Meter Reset																																																																																																														
No																																																																																																														
F G P :	P# 11																																																																																																													
Power Factor																																																																																																														
##.#																																																																																																														
F G P :	P# 12																																																																																																													
Mtr Therm Usage																																																																																																														
##	%MTU																																																																																																													

You can modify the metering values that are displayed on the SMC Flex controller to show your desired values by accessing Main Menu/Preferences.

Optional HIM Operation

The SMC Flex™ controller offers a variety of unique control options that provide enhanced motor starting and stopping capabilities. (See [Chapter 1](#) for brief descriptions of each option.)

Only one option can reside in a controller.

Human Interface Module

The control buttons available with the Bulletin 20-HIM LCD Human interface modules are compatible with the SMC-Flex controller's control options. [Table 30](#) through [Table 32](#) detail the functionality of each button.

IMPORTANT The logic mask port must be enabled prior to initiating control commands to the SMC Flex controller. See [page 94](#).

IMPORTANT You must wire the control terminals according to [Figure 44](#) or [Figure 55](#).

Table 30 - Button Functions for Standard Operation Modes







Option	Button	Operation
Soft Stop Current Limit Full Voltage Linear Speed		The green start button, when pressed, commences motor acceleration to full speed.
		The red stop button, when pressed, provides a coast stop, and/or resets a fault.
		The jog button, when pressed, initiates the programmed maneuver.
Preset Slow Speed		The green start button, when pressed, commences motor acceleration to full speed.
		The red stop button, when pressed, provides a coast stop and/or resets a fault.
		The jog button is not active for Preset Slow Speed. You cannot operate Slow Speed via the HIM.

Table 31 - Button Functions for Pump Control Mode



Option	Button	Operation
Pump Control		The green start button, when pressed, commences motor acceleration to full speed.
		The red stop button, when pressed, provides a coast stop, and/or resets a fault.
		The jog button, when pressed, initiates a pump stop maneuver.

Table 32 - Button Functions for Braking Control Modes









Option	Button	Operation
Smart Motor Braking		The green start button, when pressed, commences motor acceleration to full speed.
		The red stop button, when pressed, provides a coast stop, and/or resets a fault.
		The jog button, when pressed, initiates a brake stop.

Table 32 - Button Functions for Braking Control Modes (Continued)

Option	Button	Operation
Accu-Stop		The green start button, when pressed, commences motor acceleration to full speed.
		The red stop button, when pressed, will provide a coast stop, and/or reset a fault.
		With a “stopped” status, the jog button, when pressed, initiates slow speed motor operation. From an “at speed” condition, the jog button, when pressed, initiates braking to slow speed operation. The controller maintains slow speed operation as long as the jog button is pressed.
Slow Speed with Braking		The green start button, when pressed, commences motor acceleration to full speed.
		The red stop button, when pressed, provides a coast stop, and/or resets a fault.
		The jog button initiates a brake stop. You cannot operate Slow Speed via the HIM.



ATTENTION: The Bulletin 20-HIM LCD Human interface module’s stop push button is not intended to be used as an emergency stop. Refer to applicable standards for emergency stop requirements.

Communication

The SMC Flex™ controller provides advanced communication capabilities that let you control, configure and monitor the product through multiple devices and over multiple communication networks. The SMC Flex controller uses DPI as an internal method of communication bus; therefore, you can use all standard DPI communication devices that are used by other Rockwell Automation products (for example, PowerFlex® Drives) in the SMC Flex controller. SCANPort™ devices are not supported by the SMC Flex controller.

Standard DPI communication cards are available for various protocols, including EtherNet/IP™, DeviceNet, ControlNet, ModBus™, Remote I/O, and Profibus® DP. Other modules may be available in the future. For specific programming examples, configuration, or programming information, see the user manual for the communication module being used. [Table 33](#) shows a list of available modules.

Table 33 - Communication Card Selection by Protocol Type

Protocol Type	Cat. No.	User Manual
DeviceNet	20-COMM-D	20COMM-UM002
ControlNet	20-COMM-C	20COMM-UM003
Remote I/O	20-COMM-R	20COMM-UM004
Profibus®	20-COMM-P	20COMM-UM006
RS-485	20-COMM-S	20COMM-UM005
InterBus	20-COMM-I	20COMM-UM007
EtherNet/IP	20-COMM-E	20COMM-UM010
Dual Port EtherNet/IP	20-COMM-ER	20COMM-UM015
RS485 HVAC	20-COMM-H	20COMM-UM009
ControlNet (Fiber)	20-COMM-Q	20COMM-UM003
CANopen	20-COMM-K	20COMM-UM012
Modbus/TCP Adapter	20-COMM-M	20COMM-UM014

Communication Ports

The SMC Flex controller supports three DPI ports for communication. Ports 2 and 3 are supported through the DPI connection on the side of the device and are typically used to interface with a Human Interface Module (HIM). Port 2 is the default connection; port 3 is available by installing a splitter on port 2. Port 5 is supported by connecting one of the communication cards listed in [Table 33](#) to the internal DPI comm card connection.

Human Interface Module

You can program the SMC Flex controller with the built-in keypad and LCD display or with our optional Bulletin 20-HIM LCD human interface modules. You can install a maximum of two HIM modules. Parameters are organized in a three-level menu structure and divided into programming groups.

The human interface modules have two sections: a display panel and a control panel. The display panel duplicates the 3-line, 16-character backlit LCD display and programming keypad found on the front of the SMC Flex controller.





You must use a Bulletin 20-HIM Rev3.002 or later with the SMC Flex controller.

IMPORTANT Node addressing of the DPI communication card can be programmed via software or a hand-held DPI HIM. The on-board HIM cannot be used to address the communication card.

Keypad Descriptions

[Table 34](#) describes the keys that are on the front of the SMC Flex controller.

Table 34 - SMC Flex Controller Keypad

Menu Button	Name	Function
	Escape	Exit a menu, cancel a change to a parameter value, or acknowledge a fault/ alarm.
	Select	Select a digit, select a bit, or enter edit mode in a parameter screen. Will get to menu to change the language being displayed.
	Up/Down Arrows	Scroll through options increase/decrease a value, or toggle a bit.
	Enter	Enter a menu, enter edit mode in a parameter screen, or save a change to a parameter value.



For ease of programming values, after using the Enter key to edit, use the Sel key to jump to the digit that needs to be modified, then use the arrow keys to scroll through the digits.

If a human interface module is disconnected from the SMC Flex controller while the Logic Mask is set to 1, a “Coms Loss” fault occurs.

Extension cables are available up to a maximum of 10 m in total length.

The control panel of the 20-HIM module provides the operator interface to the controller. [Table 35](#) describes the buttons on the control panel.

Table 35 - 20-HIM Control Panel Buttons

Button Name	Description
	The green start button, when pressed, will begin motor operation. (Proper setup of the HIM port is required.)
	The red stop button, when pressed, will halt motor operation and/or reset a fault.
	The jog button is active only when a control option is present. Pressing the jog button will initiate the option maneuver (for example: Pump Stop).



ATTENTION: The Bulletin 20-HIM interface module’s stop push button is not intended to be used as an emergency stop. See the applicable standards for emergency stop requirements.



ATTENTION: The external HIM has a similar programming operation to the built-in programmer, but note that there are differences.

All other controls available with the various human interface modules are non-functional with the SMC Flex controller.

Connect the Human Interface Module to the Controller

[Figure 76](#) shows the connection of the SMC Flex controller to a human interface module. [Table 36](#) provides a description of each port.

IMPORTANT The SMC Flex controller only supports the use of DPI communication modules and DPI HIM LCD Modules. ScanPort devices are not supported by the SMC Flex controller.

See [Figure 44](#) for the control wiring diagram that enables start-stop control from a human interface module.

Figure 76 - SMC Flex Controller with Human Interface Module

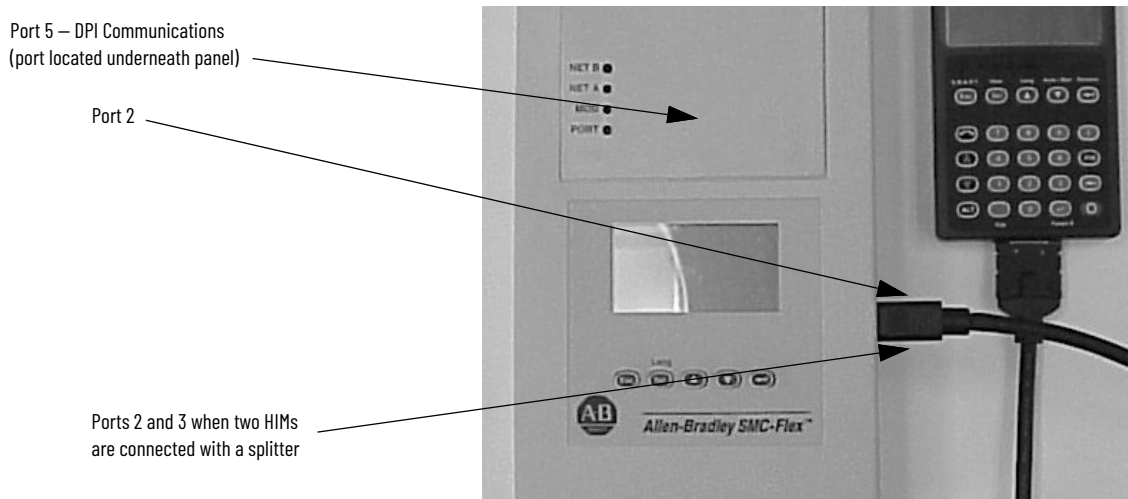

Table 36 - Description of Ports

Port #	Description
1	Unused – not available for use
2	First 20-HIM module or 20-COMM card connected to SMC Flex controller
3	Second 20-HIM connected to SMC Flex controller
5	DPI Communication Board port

Control Enable

The Logic Mask parameter (Parameter 87) lets you configure whether a communication device (HIM or network connection) can perform control commands such as starting. you can enable or disable each communication port as required.

When a given device is enabled through the logic mask, that device is allowed to execute control commands. Disconnecting any device with the logic mask enabled results in a communication fault unless the communication fault is disabled.

When a given device is disabled through the logic mask, that device cannot execute control commands, but can still be used for monitoring. A device that is disabled through the logic mask can be disconnected without causing a fault.

IMPORTANT Stop commands override all start commands and can be initiated from the hardwired inputs or any port regardless of the logic mask.

HIM and COMM Card Control Enable

To enable motor control from a connected human interface module or 20-COMM communication card, follow the procedure below with the connected human interface module's programming keys.

You can start and stop the SMC Flex controller with the control panels of the Bulletin 20-HIM LCD human interface modules. However, the factory default settings disable control commands other than Stop through the serial communication port.

To enable motor control from a connected human interface module or communication module, you must take the following programming steps:

1. Disconnect the HIM and allow to power down.
2. Reconnect the HIM. On Initializing screen, the bottom right corner of LCD shows Port X. Note this port number.

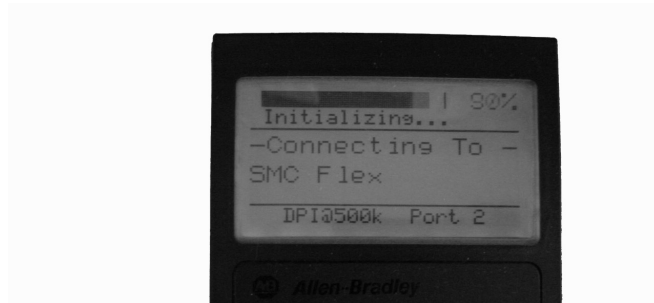

3. Go to Logic Mask, found as follows:
Main Menu: Parameter/Communications/Comm Mask/Logic Mask (Parameter 87)

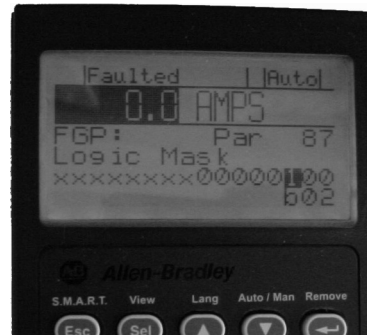

4. Set b0X equal to 1 (where X is the port number noted in [step 2](#)).

IMPORTANT You must set the Logic Mask to 0 before you disconnect a HIM from the SMC Flex controller. If you do not do this, the unit faults on a "Coms Loss"

If you are enabling control from the built-in SMC Flex controller programmer, set the Logic Mask as shown in [Table 37](#).

Table 37 - Logic Mask (Parameter 87) Requirements

Mask Code	Mask Code (Binary)	Description
0	0000 0000	No external DPI devices are enabled
4	0000 0100	Only the 20-HIM on port 2 is enabled
8	0000 1000	Reserved for the 20-HIM-A6 Handheld HIM that is connected to Port 3
12	0000 1100	Two 20-HIMs are enabled on ports 2 and 3
32	0010 0000	Only the DPI communication card on port 5 is enabled
36	0010 0100	20-HIM on port 2 and the DPI communication card on port 5 are enabled
44	0010 1100	20-HIMs on ports 2 and 3 and the DPI communication card on port 5 are enabled

Loss of Communication and Network Faults

The loss of communication fault will follow the functionality as defined in the DPI specification. There are separate faults for each device. Because three DPI ports are supported there will be three faults that can be generated.

DPI provides a separate network fault for each port. This fault can be generated directly by the peripheral and is separate from the Communications Loss fault (which is generated by the SMC Flex itself).

SMC Flex Controller-specific Information

You can use the SMC Flex controller with all LCD-applicable DPI interfaces. Regardless of the type of interface being used, you can use the information in this section to configure the rest of the system.

Default Input/Output Configuration

The default configuration for I/O is 4 bytes in and 4 bytes out (TX = 4 bytes, RX = 4 bytes). The total size may vary when used with a communication card. The default configuration is arranged according to the following table.

	Produced Data (Status)	Consumed Data (Control)
Word 0	Logic Status	Logic Command
Word 1	Feedback ⁽¹⁾	Reference ⁽²⁾

(1) The feedback word is always Current in Phase A (Parameter 4).

(2) The reference word is not used with the SMC Flex controller, however the space must be reserved.

IMPORTANT The total size produced or consumed may vary, depending on the communication card being used. For more information, refer to the User Manual for the communication card.

Variable Input/Output Configuration

The SMC Flex controller supports 16-bit DataLink™, which means that you can configure the device to return additional information. The I/O message size depends on how many DataLinks are enabled. The following table summarizes the I/O data sizes.

Table 38 - I/O Data Size

Tx Size [bytes]	Rx Size [bytes]	Logic Status/Command (16-bit)	Reference/Feedback (16-bit)	DataLinks			
				A	B	C	D
4 (8 for Ethernet options)	4	x	x				
8 (12 for Ethernet options)	8	x	x	x			
12 (16 for Ethernet options)	12	x	x	x	x		
16 (20 for Ethernet options)	16	x	x	x	x	x	
20 (24 for Ethernet options)	20	x	x	x	x	x	x

The increased transmission sizes for Ethernet (and ControlNet) option modules is due to a required 2-word /4-byte overhead. To configure DataLink, see [page 98](#).

Bit Identification

Table 39 and Table 40 Describe the bit identification for the SMC Flex Controller.

Table 39 - Bit Identification—Logic Status Word

Bit #																Status	Description
15	14	13	12	11	10	9	8	7	6	5	4	3	2	1	0		
															X	Enabled	1 – Control Power Applied 0 – No Control Power
														X		Running	1 – Power Applied to Motor 0 – Power not Applied to Motor
												X				Phasing	1 – ABC Phasing 0 – CBA Phasing
											X					Phasing Active	1 – 3-phase is valid 0 – No valid 3-phase detected
										X						Starting (Accel)	1 – Performing a Start Maneuver 0 – Not Performing a Start Maneuver
									X							Stopping (Decel)	1 – Performing a Stop Maneuver 0 – Not Performing a Stop Maneuver
								X								Alarm	1 – Alarm Present 0 – No Alarm Present
							X									Fault	1 – Fault Condition Exists 0 – No Fault Condition
						X										At Speed	1 – Full Voltage Applied 0 – Not Full Voltage Applied
					X											Start/Isolation	1 – Start/Isolation Contactor Enabled 0 – Start/Isolation Contactor Disabled
				X												Bypass	1 – External Bypass Contactor Enabled 0 – External Bypass Contactor Disabled
			X													Ready	1 – Ready 0 – Not Ready
		X														Option 1 Input	1 – Input Active 0 – Input Inactive
	X															Option 2 Input	1 – Input Active 0 – Input Inactive
–																–	Bits 14 and 15 – Not Used

Table 40 - Bit Identification—Logic Command Word (Control)

Bit #																Status	Description
15	14	13	12	11	10	9	8	7	6	5	4	3	2	1	0		
															X	Stop	1 – Stop/Inhibit 0 – No Action
														X		Start	1 – Start 0 – No Action
												X				Option #1 Input	1 – Stop Maneuver/Inhibit 0 – No Action
											X					Clear Faults	1 – Clear Faults 0 – No Action
										X						Option #2 Input	1 – Perform Option 2 function 0 – No Action
–																–	Bits 5...10 – Not Used
				X												Aux Enable	1 – Use Aux 1...Aux 4 0 – Ignore Aux 1...Aux 4
			X													Aux 1	1 – Aux 1 Active 0 – Aux 1 Inactive
		X														Aux 2	1 – Aux 2 Active 0 – Aux 2 Inactive
	X															Aux 3	1 – Aux 3 Active 0 – Aux 3 Inactive
X																Aux 4	1 – Aux 4 Active 0 – Aux 4 Inactive

Reference/Feedback

The SMC Flex controller does not offer the analog **Reference** feature. The analog **Feedback** feature is supported and will provide Parameter 1, Current in Phase A, automatically as the feedback word.

Parameter Information

A complete listing of the SMC Flex parameters is in the spreadsheet that is attached to this pdf. See [page 7](#).

Scale Factors for PLC Communication

The parameter values stored and produced by the SMC Flex controller through communication are unscaled numbers. When reading or writing values from a PLC image table, it is important to apply the proper scaling factor, which is based on the number of decimal places.

Read Example

Power Factor (Parameter 11)— The stored value is 85. Because this value has two decimal places, the value should be divided by 100. The correctly read value is 0.85.

Write Example

Motor FLC (Parameter 46)— The value that is to be written to the SMC Flex controller is 75 A. Because this value has one decimal place, the value should be multiplied by 10. The correctly written value is 750.

Display Text Unit Equivalents

Some parameters have text descriptions when you view them from a HIM or through a communication software program such as RSNetwork[™]. When receiving or sending information from a PLC, each text description has a numerical equivalent. [Table 41](#) shows an example of Overload Class (Parameter 44) and the appropriate relationship between the text descriptor and the equivalent value. This relationship is identical for other similar parameters.

Table 41 - Overload Class (Parameter 44) Text Equivalents

Text Descriptor	Numerical Equivalent
Disabled	0
Class 10	1
Class 15	2
Class 20	3
Class 30	4

Configuring DataLink

DataLink™ is supported in the SMC Flex controller. DataLink is a mechanism that most drives use to transfer data to and from the controller without using an explicit message. The SMC Flex controller supports a 16-bit DataLink, allowing you to configure the device to return up to four additional pieces of information without the need for an explicit message.

Criteria for Using DataLink

- Each set of DataLink parameters in an SMC Flex controller can be used by only one adapter. If more than one adapter is connected, multiple adapters must not try to use the same DataLink.
- Parameter settings in the SMC Flex controller determine the data passed through the DataLink mechanism.
- When DataLink is used to change a value in the SMC Flex controller, the value is not written to the Non-Volatile Storage (NVS). However, if the SMC Flex controller is powered down, the current value is written to NVS.

To configure DataLink, you must use Parameters 88...103 of the SMC Flex controller. For additional information about DataLink, see the communication interface's user manual.

IMPORTANT Node addressing of the DPI communication card can be programmed via software or a hand-held DPI HIM. You cannot use the on-board HIM to address the communication card.

Updating Firmware

Download firmware, associated files (such as AOP, EDS, and DTM), and access product release notes from the Product Compatibility and Download Center at rok.auto/pcdc.

Diagnostic Capabilities

This chapter describes the fault diagnostic capabilities of the SMC Flex™ controller. This section also describes the conditions that can cause various faults to occur.

Protection Programming

You can enable and adjust any of the protective features available with the SMC Flex controller by using the programming parameters provided. See [Chapter 4](#).

Fault Display

The SMC Flex controller is equipped with a built-in three-line, 16-character LCD. The LCD displays the unit has faulted on the first line, the fault number on the second line, and the fault code on the third line.

Fault Display

Faulted

Fault #1
Line Loss A

IMPORTANT The fault display remains active as long as control power is applied. If control power is cycled, the fault is cleared, the controller re-initializes, and the display shows a status of “Stopped.”

IMPORTANT You can press Esc to get to another programming/diagnostic list, but the SMC Flex controller remains in a faulted state.

IMPORTANT Resetting a fault does not correct the cause of the fault condition. You must take corrective action before you reset the fault.

Clear Fault

You can clear a fault using any of several methods:

- Program the SMC Flex controller for a Clear Fault, which you can find in Main Menu/Diagnostics/Faults.
- Hold Esc key on the control module keypad for 3 seconds. (Firmware version 6.001 or higher required)
- If you connect a human interface module to the controller, press the Stop button.

IMPORTANT A stop signal from HIM always stops the motor and clears the fault, regardless of Logic Mask.

- If a RESET push button is present, you can connect the N.O. push button auxiliary contact to Option Input #2 (terminal 15). Option Input #2 must be programmed for Clear Fault.
- Cycle control power to the SMC Flex controller.

IMPORTANT You cannot reset an overload fault until the Motor Thermal Usage, parameter 12, value is below 75%. See [page 17](#).

Fault Buffer

The SMC Flex controller stores in memory the five most recent faults. Display the fault buffer by selecting the View Faults Queue and scrolling through the fault buffer parameters. The information is stored as fault codes and fault descriptions.

The five most recent faults are also stored as the values of Fault 1 (Parameter 124) through Fault 5 (Parameter 128). Fault 1 is the current fault and Fault 5 is the oldest fault in memory.

Fault Codes

[Table 42](#) provides a complete cross-reference of the available fault codes and corresponding fault descriptions.

Table 42 - Fault Code Cross-reference

Fault	Code	Fault	Code
Line Loss A	1	Stall	25
Line Loss B	2	Phase Reversal	26
Line Loss C	3	Coms Loss P2	27
Shorted SCR A	4	Coms Loss P3	28
Shorted SCR B	5	Coms Loss P5	29
Shorted SCR C	6	Network P2	30
Open Gate A	7	Network P3	31
Open Gate B	8	Network P5	32
Open Gate C	9	Ground Fault	33
PTC Pwr Pole	10	Excess Starts	34
SCR Overtemp	11	Power Loss A	35
Motor PTC	12	Power Loss B	36
Open Bypass A	13	Power Loss C	37
Open Bypass B	14	Hall ID	38
Open Bypass C	15	NVS Error	39
No Load A	16	No Load	40
No Load B	17	Line Loss A	41 ⁽¹⁾
No Load C	18	Line Loss B	42 ⁽¹⁾
Line Unbalance	19	Line Loss C	43 ⁽¹⁾
Overvoltage	20	V24 Loss	45
Undervoltage	21	V Control Loss	46
Overload	22	Input 1	48
Underload	23	Input 2	49
Jam	24	System Faults	128...209

(1) See [Table 43](#) for definition.

Fault and Alarm Auxiliary Indication

You can program auxiliary contacts for Fault or Alarm, N.O., or N.C. indication. Parameter setup is in the Parameter/Motor Protection group when you modify parameters in Program Mode.

Fault Definitions

[Table 43](#) shows the fault definitions for the SMC Flex controller. The unit trips and stops after any of these faults occurs.

Table 43 – Fault Definitions

Fault	Description	
Line Loss F1, F2, F3	A line connection was lost	
Shorted SCR	Shorted SCR detected. Starting prohibited.	
Open Gate	The controller sensed an abnormal condition that causes faulty firing (such as an open SCR gate) during the start sequence.	The SMC Flex controller attempts to start the motor a total of three times before the controller shuts down.
Power Pole PTC and SCR Overtemperature	The power pole temperature in any phase rises above the predetermined level.	You can perform a reset after the temperature falls below this level.
Motor PTC	The motor PTC that is connected to terminals 23 and 24 PTC tripped.	PTC Parameter must be enabled.
Open Bypass	The SMC Flex controller does not sense a power pole bypass contact closure,	
No Load	A load connection has been lost.	
Line Unbalance ⁽¹⁾	The controller shuts down when the calculated voltage unbalance reaches the user-programmed trip percentages.	Voltage unbalance is detected by monitoring the three-phase supply voltages. The formula used to calculate the percentage voltage unbalance is as follows: $V_u = 100 (V_d / V_a)$ V_u : Percent voltage unbalance V_d : Maximum voltage deviation from the average voltage V_a : Average voltage
Overvoltage and Undervoltage Protection ⁽¹⁾	The calculated average is compared to the programmed trip level and trips when it is exceeded.	The SMC Flex controller continuously monitors the three supply phases. Overvoltage and undervoltage protection are user-defined as a percentage of the programmed line voltage. User-defined values can be adjusted for nuisance tripping.
Underload ⁽²⁾	The controller shuts down when the motor current drops below the trip level.	The trip level is a percentage of the motor's FLA rating.
Overload Protection ⁽³⁾	You can enable overload protection in the Motor Protection group by programming the: <ul style="list-style-type: none"> • Overload class • Overload reset • Motor FLC • Service factor 	
Phase Reversal	The incoming power to the controller is in any sequence other than ABC.	You can disable this pre-start protective feature.
Coms Loss	If a Bulletin 20-HIM LCD Human interface module is disconnected from the SMC Flex controller when control is enabled, a Comm Fault occurs. Other settings could also cause this fault..	The SMC Flex controller disables control through the DPI communication port as the factory default. To enable control, you must set the Logic Mask in the Communication programming group. See Table 37
Network	Network faults are faults generated on the network external to the SMC Flex controller, and are annunciated on the LCD display.	
Ground Fault	Ground fault was detected.	Based on feedback from the user-supplied current transformer (see page 21) detecting ground fault currents. You must program the ground fault level and ground fault time delay parameters for proper operation.
Excess Starts/Hour	The number of starts in a one-hour period exceeds the value that is programmed.	
Power Loss	An input power phase is not present. The controller's LCD display identifies the missing phase.	If all three phases are absent when a start command is issued, the LCD displays "Starting" without motor rotation.
Line Loss F41, F42, F43	The controller indicates a fault if the SCR conduction is discontinuous.	During expected SCR gate periods, the controller monitors the power pole voltage and current.

(1) Phase loss, overvoltage, and undervoltage protection are disabled during braking operation.

(2) Jam detection and underload protection are disabled during slow speed and braking operation.

(3) See [page 86](#) for more information.

Notes:

Troubleshooting

For safety of maintenance personnel and others who might be exposed to electrical hazards associated with maintenance activities, follow the local safety related work practices (for example, NFPA 70E, Part II in the United States). Maintenance personnel must be trained in the safety practices, procedures, and requirements that pertain to their respective job assignments.



SHOCK HAZARD: Hazardous voltage is present in the motor circuit even when the SMC Flex™ controller is off. To avoid shock hazard, disconnect main power before working on the controller, motor, and control devices (for example, Start-Stop push buttons). Procedures that require parts of the equipment to be energized during troubleshooting, testing, etc., must be performed by properly qualified personnel using appropriate local safety work practices and precautionary measures.



ATTENTION: Disconnect the controller from the motor before measuring insulation resistance (IR) of the motor windings. Voltages used for insulation resistance testing can cause SCR failure. Do not make any measurements on the controller with an IR tester (megger).

The flowchart in [Figure 77](#) aids in quick troubleshooting.



The time it takes for the motor to come up to speed may differ from the time programmed. This depends upon the motor and load characteristics.

Depending upon the application, the braking options (SMB and Slow Speed) may cause some vibration or noise during the stopping cycle. To minimize vibration or noise, lower the braking current adjustment. If this is a concern in your application, please consult your local Rockwell Automation sales office or Allen-Bradley distributor before you implement the braking options.

Figure 77 - Troubleshooting Flowchart

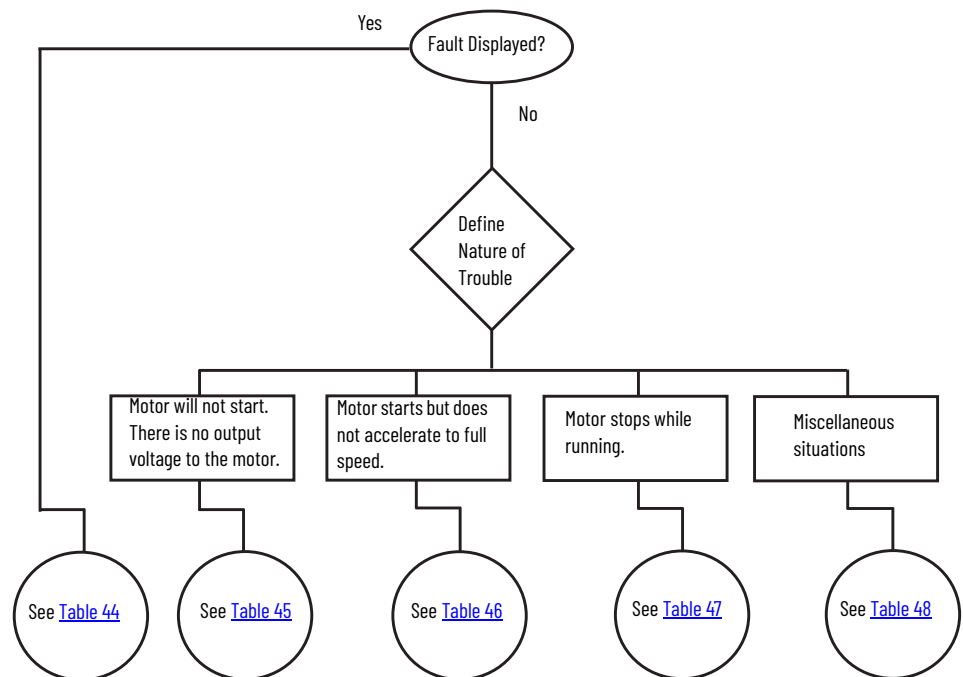

Table 44 - SMC Fault Display Explanation

Display	Fault Code	Possible Causes	Possible Solutions
Line Loss ⁽¹⁾ (with phase indication)	1, 2, 3	<ul style="list-style-type: none"> Missing supply phase Motor not connected properly 	<ul style="list-style-type: none"> Check for line and load loose connections Check for open line (for example, blown fuse) Check for open line lead(s) Verify power quality
Shorted SCR	4, 5, 6	<ul style="list-style-type: none"> Shorted Power Module 	<ul style="list-style-type: none"> Check for shorted SCR, replace power module if necessary
Open Gate (with phase indication)	7, 8, 9	<ul style="list-style-type: none"> Open gate circuitry Loose gate lead 	<ul style="list-style-type: none"> Perform resistance check; replace power module if necessary Check gate lead connections to the control module
PTC Power Pole SCR Overtemp	10, 11	<ul style="list-style-type: none"> Controller ventilation blocked Controller duty cycle exceeded Fan failure Ambient temperature limit exceeded Failed thermistor Failed power or control module 	<ul style="list-style-type: none"> Check for proper ventilation Check application duty cycle Check for fan operation. Replace fan if necessary. Wait for controller to cool or provide external cooling Replace power module or control module as needed
Motor PTC	12	<ul style="list-style-type: none"> Motor ventilation blocked Motor duty cycle exceeded PTC open or shorted 	<ul style="list-style-type: none"> Check for proper ventilation Check application duty cycle Wait for motor to cool or provide external cooling Check resistance of PTC
Open Bypass	13, 14, 15	<ul style="list-style-type: none"> Control voltage is low Inoperable power module bypass 	<ul style="list-style-type: none"> Check control voltage power supply Replace power module Check control module TB2...TB4 and TB5...TB7 for proper connection and secureness Check Aux 1, 2, 3, 4 configurations are not set to External Bypass
No Load	16, 17, 18, 40	<ul style="list-style-type: none"> Loss of load side power wiring 	<ul style="list-style-type: none"> Check all load side power connections and motor windings
Line Unbalance	19	<ul style="list-style-type: none"> Power line unbalance is greater than the user-programmed value The delay time is too short for the application 	<ul style="list-style-type: none"> Check power system and correct if necessary Extend the delay time to match the application requirements
Overvoltage	20	<ul style="list-style-type: none"> Power line grid voltage is greater than the programmed value Abnormal voltage regulation The parameter settings and/or delay time programmed are not suited for the application 	<ul style="list-style-type: none"> Check power system and correct if necessary, or change the programmed value Correct the user-programmed value
Undervoltage	21	<ul style="list-style-type: none"> Power line grid voltage is less than the programmed value Abnormal voltage regulation The parameter settings and or delay time programmed are not suited for the application 	<ul style="list-style-type: none"> Check power system and correct if necessary Modify the parameter and/or extend the delay time to match the application requirements.
Overload	22	<ul style="list-style-type: none"> Motor overloaded Overload parameters are not matched to the motor 	<ul style="list-style-type: none"> Check motor overload condition Check programmed values for overload class and motor FLC
Underload	23	<ul style="list-style-type: none"> Broken motor shaft Broken belts, toolbits, etc. Pump cavitation 	<ul style="list-style-type: none"> Repair or replace motor Check machine Check pump system
Jam	24	<ul style="list-style-type: none"> Motor current has exceeded the user programmed jam level. 	<ul style="list-style-type: none"> Correct source of jam Check programmed time value
Stall	25	<ul style="list-style-type: none"> Motor has not reached full speed by the end of the programmed ramp time 	<ul style="list-style-type: none"> Check pump system, machine drive components, and loading; repair or replace motor, if necessary. Check programmed settings
Phase Reversal	26	<ul style="list-style-type: none"> Incoming supply voltage is not in the expected ABC sequence 	<ul style="list-style-type: none"> Check power wiring and correct if necessary
Coms Loss	27, 28, 29	<ul style="list-style-type: none"> Communication disconnection at the serial port 	<ul style="list-style-type: none"> Check for a communication cable disconnection to the SMC Flex controller
Network	30, 31, 32	<ul style="list-style-type: none"> DPI network loss 	<ul style="list-style-type: none"> Reconnect for each DPI connected device
Ground Fault	33	<ul style="list-style-type: none"> Ground fault current level has exceeded programmed value 	<ul style="list-style-type: none"> Check power system and motor; correct if necessary Check programmed ground fault levels to match application requirements
Excess Starts/Hr.	34	<ul style="list-style-type: none"> Number of starts in a one hour period has exceeded the value programmed 	<ul style="list-style-type: none"> Wait an appropriate amount of time to restart Reduce the actual number of starts per hour or increase the programmed start time (if allowed by the application) and controller thermal limits Turn off the Starts/Hr. feature
Power Loss ⁽¹⁾ (with phase indication)	35, 36, 37	<ul style="list-style-type: none"> Missing supply phase (as indicated) 	<ul style="list-style-type: none"> Check for open line (blown line fuse)

Table 44 - SMC Fault Display Explanation (Continued)

Display	Fault Code	Possible Causes	Possible Solutions
Hall ID	38	<ul style="list-style-type: none"> Loose cables between the controller and power section Incorrect power module has been installed 	<ul style="list-style-type: none"> Remove the control module from the power section; verify connectors are firmly seated to the control module Check power module and replace if necessary
NVS Error	39	<ul style="list-style-type: none"> Controller memory corrupted 	<ul style="list-style-type: none"> Modify a parameter or load parameter defaults (preferred) and reload the customer-specific parameters. Replace control module if necessary
Line Loss	41, 42, 43	<ul style="list-style-type: none"> Line distortion High impedance connection 	<ul style="list-style-type: none"> Check supply voltage for capability to start/stop motor Check for loose connections on line side or motor side of power wires
V24 Recovery	F44	<ul style="list-style-type: none"> Control module internal 24V control power stays low after closing bypass contactor 	<ul style="list-style-type: none"> Check control power. Make sure it is within the operating parameters of the SMC Flex controller Check control power connections, including ground, to the control module Replace control module
V24 Loss	F45	<ul style="list-style-type: none"> Control module internal 24V supply out of normal range 	<ul style="list-style-type: none"> Same as F44
V Control	F46	<ul style="list-style-type: none"> Sense of control voltage in error 	<ul style="list-style-type: none"> Same as F44
Option Input 1, 2	F48, F49	<ul style="list-style-type: none"> Fault occurs based on the user configuration of the option input 	<ul style="list-style-type: none"> Review the option input fault configuration and clear the fault condition
Varies (control module system faults)	F128...F209	<ul style="list-style-type: none"> Control module wiring Control module defective 	<ul style="list-style-type: none"> Review the control module wiring. Ensure ground terminal is secure connected to system earth ground. Ensure an RC snubber is connected to all inductive loads in the control circuit (refer to input wiring) Replace the control module

(1) Prestart fault indication.

Table 45 - Motor Will Not Start – No Output Voltage to the Motor

Display	Possible Cause	Possible Solutions
Fault displayed	<ul style="list-style-type: none"> See fault description 	<ul style="list-style-type: none"> See Table 44 addressing fault conditions
Display is blank	<ul style="list-style-type: none"> Control voltage is absent Failed control module 	<ul style="list-style-type: none"> Check control wiring and correct if necessary Replace control module Cycle control power
Stopped 0.0 Amps	<ul style="list-style-type: none"> Pilot devices SMC Enable input is open at terminal 13 Input terminals are not wired correctly Start-Stop control has not been enabled for the human interface module Control voltage Failed control module 	<ul style="list-style-type: none"> Check wiring Follow the instructions on page 92 to enable control capability Check control voltage Replace control module
Starting	<ul style="list-style-type: none"> Two or three power phases are missing 	<ul style="list-style-type: none"> Check power system

Table 46 - Motor Rotates (but does not accelerate to full speed)

Display	Possible Cause	Possible Solutions
Fault displayed	<ul style="list-style-type: none"> See fault description 	<ul style="list-style-type: none"> See Table 44 addressing fault conditions
Starting	<ul style="list-style-type: none"> Mechanical problems Inadequate Current Limit setting Failed control module 	<ul style="list-style-type: none"> Check for binding or external loading and correct Check motor Adjust the Current Limit Level to a higher setting Replace control module

Table 47 - Motor Stops While Running

Display	Possible Cause	Possible Solutions
Fault displayed	<ul style="list-style-type: none"> See fault description 	<ul style="list-style-type: none"> See Table 44 addressing fault conditions
Display is blank	<ul style="list-style-type: none"> Control voltage is absent Failed control module 	<ul style="list-style-type: none"> Check control wiring and correct if necessary Replace control module
Stopped 0.0 Amps	<ul style="list-style-type: none"> Pilot devices Failed control module 	<ul style="list-style-type: none"> Check control wiring and correct if necessary Replace control module
Starting	<ul style="list-style-type: none"> Two or three power phases are missing Failed control module 	<ul style="list-style-type: none"> Check power system Replace control module

Table 48 - Miscellaneous Situations

Situation	Possible Cause	Possible Solutions
Motor current and voltage fluctuates with steady load	<ul style="list-style-type: none"> • Motor • Erratic Load 	<ul style="list-style-type: none"> • Verify type of motor as a standard squirrel cage induction motor • Check load conditions
Erratic operation	<ul style="list-style-type: none"> • Loose connections 	<ul style="list-style-type: none"> • Shut off all power to controller and check for loose connections
Accelerates too fast	<ul style="list-style-type: none"> • Starting time • Initial torque • Current limit setting • Kickstart 	<ul style="list-style-type: none"> • Increase starting time • Lower initial torque setting • Decrease current limit setting • Lower kickstart time or turn off • Confirm Motor FLC (Parameter 46) is set properly
Accelerates too slow	<ul style="list-style-type: none"> • Starting time • Initial torque • Current limit setting • Kickstart 	<ul style="list-style-type: none"> • Decrease starting time • Increase initial torque setting • Increase current limit setting • Increase kickstart time or turn off • Confirm Motor FLC (Parameter 46) is set properly
Fan does not operate	<ul style="list-style-type: none"> • Wiring • Failed fan(s) 	<ul style="list-style-type: none"> • Check wiring and correct if necessary • Replace fan module
Motor stops too quickly with Soft Stop option	<ul style="list-style-type: none"> • Time setting 	<ul style="list-style-type: none"> • Verify the programmed stopping time and correct if necessary
Motor stops too slowly with Soft Stop option	<ul style="list-style-type: none"> • Stopping time setting • Misapplication 	<ul style="list-style-type: none"> • Verify the programmed stopping time and correct if necessary • The Soft Stop option is intended to extend the stopping time for loads that stop suddenly when power is removed from the motor
Fluid surges with pumps still occur with the Soft Stop option	<ul style="list-style-type: none"> • Misapplication 	<ul style="list-style-type: none"> • Soft Stop ramps voltage down over a set period of time. In the case of pumps, the voltage may drop too rapidly to prevent surges. A closed loop system such as Pump Control would be more appropriately suited. • See publication 150-TD009
Motor overheats	<ul style="list-style-type: none"> • Duty cycle 	<ul style="list-style-type: none"> • Preset Slow Speed and Accu-Stop options: Extended operation at slow speeds reduces motor cooling efficiency. Consult motor manufacturer for motor limitations. • Smart Motor Braking option: Check duty cycle. Consult motor manufacturer for motor limitations.
Motor short circuit	<ul style="list-style-type: none"> • Winding fault 	<ul style="list-style-type: none"> • Identify fault and correct. • Check for shorted SCR; replace if necessary. • Ensure power terminals are secure.

Power Module Check

If you need to check a power module, use the procedure that follows.



ATTENTION: To avoid shock hazard, disconnect main power before working on the controller, motor, or control devices such as Start/Stop push buttons.



ATTENTION: Make sure that wires are properly marked and programmed parameter values are recorded.

Shorted SCR Test

Using an ohmmeter, measure the resistance between the line and load terminals of each phase on the controller. (L1-T1, L2-T2, & L3-T3)

The resistance should be greater than 5,000 Ω.

Check Line Load



WARNING: Only authorized and electrically qualified persons should perform this test.

WARNING: Measure the voltage drop across the SMC poles (L1...T1) with power applied and without a start command or connected motor.

Use a voltmeter to measure the voltage across the SMC for the following:

- L1...T1
- L2...T2
- L3...T3

To verify that the voltage is correct, refer to the following table.

Table 49 - Line Load Verification Values

Voltage	Correct Voltage on each Phase	Reading if Phase A is Short
480	277	0, 480, 480
600	347	0, 600, 600

Notes:

Renewal Parts

This appendix provides a list of renewal part catalog numbers for the SMC Flex™ controller.

Table 50 - Control Modules

Description		Controller Rating	Part No. ⁽¹⁾		
			For units rated 200...600V AC		For units rated 690V AC
			100...240V AC	24V AC/DC	100...240V AC
Control Modules	Standard	All	41391-454-01-S1FX	41391-454-02-S2FX	41391-454-05-S1FZ
	Pump	All	41391-454-01-B1FX	41391-454-02-B2FX	41391-454-05-B1FZ
	Braking	5...85 A	41391-454-01-D1AX	41391-454-02-D2AX	—
		108...251 A	41391-454-01-D1BX	41391-454-02-D2BX	41391-454-05-D1BZ
		317...480 A	41391-454-01-D1CX	41391-454-02-D2CX	41391-454-05-D1CZ
		625...780 A	41391-454-01-D1DX	—	41391-454-05-D1DX
970...1250 A	41391-454-01-D1EX	—	41391-454-05-D1EZ		

(1) One piece provided per part number.

Table 51 - Power Poles

Description	Controller Rating	Series	Part No. ⁽¹⁾		
			Line Voltage		
			200...480V	200...600V	230...690V
Power Pole Cat. No. includes: • SCRs • Bypass contactor • Base housing and plate	5 A	B	150-FPP5B ⁽²⁾	150-FPP5C ⁽²⁾	—
	25 A	B	150-FPP25B ⁽²⁾	150-FPP25C ⁽²⁾	—
	43 A	B	150-FPP43B ⁽²⁾	150-FPP43C ⁽²⁾	—
	60 A	B	150-FPP60B ⁽²⁾	150-FPP60C ⁽²⁾	—
	85 A	B	150-FPP85B ⁽²⁾	150-FPP85C ⁽²⁾	—
	108 A	B	150-FPP108B ⁽²⁾	150-FPP108C ⁽²⁾	150-FPP108Z ⁽²⁾
	135 A	B	150-FPP135B ⁽²⁾	150-FPP135C ⁽²⁾	150-FPP135Z ⁽²⁾
Power Pole Cat. No. includes: • SCRs • Bypass contactor	201 A	B	150-FPP201B ⁽³⁾	150-FPP201C ⁽³⁾	150-FPP201Z ⁽³⁾
	251 A	B	150-FPP251B ⁽³⁾	150-FPP251C ⁽³⁾	150-FPP251Z ⁽³⁾
	317 A	B	150-FPP317B ⁽³⁾	150-FPP317C ⁽³⁾	150-FPP317Z ⁽³⁾
	361 A	B	150-FPP361B ⁽³⁾	150-FPP361C ⁽³⁾	150-FPP361Z ⁽³⁾
	480 A	B	150-FPP480B ⁽³⁾	150-FPP480C ⁽³⁾	150-FPP480Z ⁽³⁾
Power Pole Cat. No. includes: • SCRs	625 A	B	150-FPP625B ⁽³⁾	150-FPP625C ⁽³⁾	150-FPP625Z ⁽³⁾
	780 A	B	150-FPP780B ⁽³⁾	150-FPP780C ⁽³⁾	150-FPP780Z ⁽³⁾
	970 A	B	150-FPP970B ⁽³⁾	150-FPP970C ⁽³⁾	150-FPP970Z ⁽³⁾
	1250 A	B	150-FPP1250B ⁽³⁾	150-FPP1250C ⁽³⁾	150-FPP1250Z ⁽³⁾

(1) One piece provided per part number.

(2) Three-phase power pole structure provided.

(3) One-phase power pole provided.

Table 52 - Other Renewal Parts

Description	Controller Rating	Controller Rating	Series	Part No. ⁽¹⁾
Heatsink Fans	All	5...85 A	B	41391-801-03
		108...135 A	B	41391-801-03
		201...251 A	B	41391-801-01
		317...480 A	B	41391-801-02
	110/120V AC Control Power	625...1250 A	B	41391-801-04
	230/240V AC Control Power	625...1250 A	B	41391-801-05
Base Plate		201...251 A	B	41391-803-01
		317...480 A	B	41391-803-02
Bypass Contactor ⁽²⁾	110/120V AC Control Power	625...780 A	B	100-D180ED11
		970...1250 A	B	100-D420ED11
	230/240V AC Control Power	625...780 A	B	100-D180EA11
		970...1250 A	B	100-D420EA11
SMC Flex Hall Effect Sensor Replacement Kits ⁽³⁾	All	625 A	A	150-FRH625
		780 A	A	150-FRH780
		970 A	A	150-FRH970
		1250 A	A	150-FRH1250

(1) One piece provided per part number.

(2) See publication [150-IN064](#).

(3) See publication [150-IN016](#).

Renewal Parts Cross Reference

This appendix provides a cross reference from the originally ordered Cat. No., the label on the internal control module, and the orderable Cat. No. of the replacement part.

Table 53 - Control Modules

Controller Type	Controller Rating	Line Voltage	Control Input Voltage	Orderable Renewal Part No.	Control Module Cat. No. on the Label ⁽¹⁾
Standard	All	200...600V	100...240V	41391-454-01-S1FX	150-FS1FX
			24V AC/DC	41391-454-02-S2FX	150-FS2FX
		690V	110/120V	41391-454-05-S1FZ	150-FS1FZ
			230/240V		
Pump	All	200...600V	100...240V	41391-454-01-B1FX	150-FB1FX
			24V AC/DC	41391-454-02-B2FX	150-FB2FX
		690V	110/120V	41391-454-05-B1FZ	150-FB1FZ
			230/240V		
Braking	5...85 A	200...600V	100...240V	41391-454-01-D1AX	150-FD1AX
			24V AC/DC	41391-454-02-D2AX	150-FD2AX
	108...251 A	200...600V	100...240V	41391-454-01-D1BX	150-FD1BX
			24V AC/DC	41391-454-02-D2BX	150-FD2BX
		690V	110/120V	41391-454-05-D1BZ	150-FD1BZ
			230/240V		
	317...480 A	200...600V	100...240V	41391-454-01-D1CX	150-FD1CX
			24V AC/DC	41391-454-02-D2CX	150-FD2CX
		690V	110/120V	41391-454-05-D1CZ	150-FD1CZ
			230/240V		
	625...780 A	200...600V	110/120V	41391-454-01-D1DX	150-FD1DX
			230/240V		
		690V	110/120V	41391-454-05-D1DZ	150-FD1DZ
			230/240V		
	970...1250 A	200...600V	110/120V	41391-454-01-D1EX	150-FD1EX
			230/240V		
690V		110/120V	41391-454-05-D1EZ	150-FD1EZ	
		230/240V			

(1) These are not orderable catalog numbers. They appear on the product label of the orderable part. If you need to order a control module see [Appendix A](#).

Table 54 - Standard Control Power Poles

Control Voltage	Line Voltage	Rated Current [A]	Originally Ordered Allen-Bradley Cat. No.	Series	Internal Control Module Label ⁽¹⁾	Orderable Power Pole Cat. No.	
100...240V	200...480V AC	5	150-F5NBD	B	150-FS1FX	150-FPP5B	
		25	150-F25NBD	B	150-FS1FX	150-FPP25B	
		43	150-F43NBD	B	150-FS1FX	150-FPP43B	
		60	150-F60NBD	B	150-FS1FX	150-FPP60B	
		85	150-F85NBD	B	150-FS1FX	150-FPP85B	
		108	150-F108NBD	B	150-FS1FX	150-FPP108B	
		135	150-F135NBD	B	150-FS1FX	150-FPP135B	
	200...600V AC	5	150-F5NCD	B	150-FS1FX	150-FPP5C	
		25	150-F25NCD	B	150-FS1FX	150-FPP25C	
		43	150-F43NCD	B	150-FS1FX	150-FPP43C	
		60	150-F60NCD	B	150-FS1FX	150-FPP60C	
		85	150-F85NCD	B	150-FS1FX	150-FPP85C	
		108	150-F108NCD	B	150-FS1FX	150-FPP108C	
		135	150-F135NCD	B	150-FS1FX	150-FPP135C	
	230...690V AC	108	150-F108NZD	B	150-FS1FZ	150-FPP108Z	
		135	150-F135NZD	B	150-FS1FZ	150-FPP135Z	
	24V AC/DC	200...480V AC	5	150-F5NBR	B	150-FS2FX	150-FPP5B
			25	150-F25NBR	B	150-FS2FX	150-FPP25B
43			150-F43NBR	B	150-FS2FX	150-FPP43B	
60			150-F60NBR	B	150-FS2FX	150-FPP60B	
85			150-F85NBR	B	150-FS2FX	150-FPP85B	
108			150-F108NBR	B	150-FS2FX	150-FPP108B	
135			150-F135NBR	B	150-FS2FX	150-FPP135B	
200...600V AC		5	150-F5NCR	B	150-FS2FX	150-FPP5C	
		25	150-F25NCR	B	150-FS2FX	150-FPP25C	
		43	150-F43NCR	B	150-FS2FX	150-FPP43C	
		60	150-F60NCR	B	150-FS2FX	150-FPP60C	
		85	150-F85NCR	B	150-FS2FX	150-FPP85C	
		108	150-F108NCR	B	150-FS2FX	150-FPP108C	
		135	150-F135NCR	B	150-FS2FX	150-FPP135C	

(1) These are not orderable catalog numbers. They appear on the product label of the orderable part. If you need to order a control module see [Appendix A](#).

Table 55 - Pump Control Power Poles

Control Voltage	Line Voltage	Rated Current [A]	Originally Ordered Allen-Bradley Cat. No.	Series	Internal Control Module Label ⁽¹⁾	Orderable Power Pole Cat. No.	
100...240V	200...480V AC	5	150-F5NBDB	B	150-FB1FX	150-FPP5B	
		25	150-F25NBDB	B	150-FB1FX	150-FPP25B	
		43	150-F43NBDB	B	150-FB1FX	150-FPP43B	
		60	150-F60NBDB	B	150-FB1FX	150-FPP60B	
		85	150-F85NBDB	B	150-FB1FX	150-FPP85B	
		108	150-F108NBDB	B	150-FB1FX	150-FPP108B	
		135	150-F135NBDB	B	150-FB1FX	150-FPP135B	
	200...600V AC	5	150-F5NCDB	B	150-FB1FX	150-FPP5C	
		25	150-F25NCDB	B	150-FB1FX	150-FPP25C	
		43	150-F43NCDB	B	150-FB1FX	150-FPP43C	
		60	150-F60NCDB	B	150-FB1FX	150-FPP60C	
		85	150-F85NCDB	B	150-FB1FX	150-FPP85C	
		108	150-F108NCDB	B	150-FB1FX	150-FPP108C	
		135	150-F135NCDB	B	150-FB1FX	150-FPP135C	
	230...690V AC	108	150-F108NZDB	B	150-FB1FZ	150-FPP108Z	
		135	150-F135NZDB	B	150-FB1FZ	150-FPP135Z	
	24V AC/DC	200...480V AC	5	150-F5NBRB	B	150-FB2FX	150-FPP5B
			25	150-F25NBRB	B	150-FB2FX	150-FPP25B
43			150-F43NBRB	B	150-FB2FX	150-FPP43B	
60			150-F60NBRB	B	150-FB2FX	150-FPP60B	
85			150-F85NBRB	B	150-FB2FX	150-FPP85B	
108			150-F108NBRB	B	150-FB2FX	150-FPP108B	
135			150-F135NBRB	B	150-FB2FX	150-FPP135B	
200...600V AC		5	150-F5NCRB	B	150-FB2FX	150-FPP5C	
		25	150-F25NCRB	B	150-FB2FX	150-FPP25C	
		43	150-F43NCRB	B	150-FB2FX	150-FPP43C	
		60	150-F60NCRB	B	150-FB2FX	150-FPP60C	
		85	150-F85NCRB	B	150-FB2FX	150-FPP85C	
		108	150-F108NCRB	B	150-FB2FX	150-FPP108C	
		135	150-F135NCRB	B	150-FB2FX	150-FPP135C	

(1) These are not orderable catalog numbers. They appear on the product label of the orderable part. If you need to order a control module see [Appendix A](#).

Table 56 - Braking Control Power Poles

Control Voltage	Line Voltage	Rated Current [A]	Originally Ordered Allen-Bradley Cat. No.	Series	Internal Control Module Label ⁽¹⁾	Orderable Power Pole Cat. No.	
100...240V	200...480V AC	5	150-F5NBDD	B	150-FD1AX	150-FPP5B	
		25	150-F25NBDD	B	150-FD1AX	150-FPP25B	
		43	150-F43NBDD	B	150-FD1AX	150-FPP43B	
		60	150-F60NBDD	B	150-FD1AX	150-FPP60B	
		85	150-F85NBDD	B	150-FD1AX	150-FPP85B	
		108	150-F108NBDD	B	150-FD1BX	150-FPP108B	
		135	150-F135NBDD	B	150-FD1BX	150-FPP135B	
	200...600V AC	5	150-F5NCDD	B	150-FD1AX	150-FPP5C	
		25	150-F25NCDD	B	150-FD1AX	150-FPP25C	
		43	150-F43NCDD	B	150-FD1AX	150-FPP43C	
		60	150-F60NCDD	B	150-FD1AX	150-FPP60C	
		85	150-F85NCDD	B	150-FD1AX	150-FPP85C	
		108	150-F108NCDD	B	150-FD1BX	150-FPP108C	
		135	150-F135NCDD	B	150-FD1BX	150-FPP135C	
	230...690V AC	108	150-F108NZDD	B	150-FD1BZ	150-FPP108Z	
		135	150-F135NZDD	B	150-FD1BZ	150-FPP135Z	
	24V AC/DC	200...480V AC	5	150-F5NBRD	B	150-FD2AX	150-FPP5B
			25	150-F25NBRD	B	150-FD2AX	150-FPP25B
43			150-F43NBRD	B	150-FD2AX	150-FPP43B	
60			150-F60NBRD	B	150-FD2AX	150-FPP60B	
85			150-F85NBRD	B	150-FD2AX	150-FPP85B	
108			150-F108NBRD	B	150-FD2BX	150-FPP108B	
135			150-F135NBRD	B	150-FD2BX	150-FPP135B	
200...600V AC		5	150-F5NCRD	B	150-FD2AX	150-FPP5C	
		25	150-F25NCRD	B	150-FD2AX	150-FPP25C	
		43	150-F43NCRD	B	150-FD2AX	150-FPP43C	
		60	150-F60NCRD	B	150-FD2AX	150-FPP60C	
		85	150-F85NCRD	B	150-FD2AX	150-FPP85C	
		108	150-F108NCRD	B	150-FD2BX	150-FPP108C	
		135	150-F135NCRD	B	150-FD2BX	150-FPP135C	

(1) These are not orderable catalog numbers. They appear on the product label of the orderable part. If you need to order a control module see [Appendix A](#).

Notes:

Rockwell Automation Support

Use these resources to access support information.

Technical Support Center	Find help with how-to videos, FAQs, chat, user forums, Knowledgebase, and product notification updates.	rok.auto/support
Local Technical Support Phone Numbers	Locate the telephone number for your country.	rok.auto/phonesupport
Technical Documentation Center	Quickly access and download technical specifications, installation instructions, and user manuals.	rok.auto/techdocs
Literature Library	Find installation instructions, manuals, brochures, and technical data publications.	rok.auto/literature
Product Compatibility and Download Center (PCDC)	Download firmware, associated files (such as AOP, EDS, and DTM), and access product release notes.	rok.auto/pcdc

Documentation Feedback

Your comments help us serve your documentation needs better. If you have any suggestions on how to improve our content, complete the form at rok.auto/docfeedback.

Waste Electrical and Electronic Equipment (WEEE)







At the end of life, this equipment should be collected separately from any unsorted municipal waste.

Rockwell Automation maintains current product environmental compliance information on its website at rok.auto/pec.

Allen-Bradley, expanding human possibility, Logix, PowerFlex, Rockwell Automation, Rockwell Software, SCANport, SMC, and SMC Flex are trademarks of Rockwell Automation, Inc. DeviceNet and EtherNet/IP are trademarks of ODVA, Inc. Trademarks not belonging to Rockwell Automation are property of their respective companies.

Rockwell Otomasyon Ticaret A.Ş. Kar Plaza İş Merkezi E Blok Kat:6 34752, İçerenköy, İstanbul, Tel: +90 (216) 5698400 EEE Yönetmeliğine Uygundur

Connect with us.    

rockwellautomation.com ————— expanding **human possibility**[®]

AMERICAS: Rockwell Automation, 1201 South Second Street, Milwaukee, WI 53204-2496 USA, Tel: (1) 414.382.2000

EUROPE/MIDDLE EAST/AFRICA: Rockwell Automation NV, Pegasus Park, De Kleetlaan 12a, 1831 Diegem, Belgium, Tel: (32) 2663 0600

ASIA PACIFIC: Rockwell Automation SEA Pte Ltd, 2 Corporation Road, #04-05, Main Lobby, Corporation Place, Singapore 618494, Tel: (65) 6510 6608

UNITED KINGDOM: Rockwell Automation Ltd., Pitfield, Kiln Farm, Milton Keynes, MK11 3DR, United Kingdom, Tel: (44)(1908) 838-800

Publication 150-UM008J-EN-P - April 2025

150-UM008I-EN-P - October 2020

Copyright © 2025 Rockwell Automation, Inc. All rights reserved. Printed in the U.S.A.