

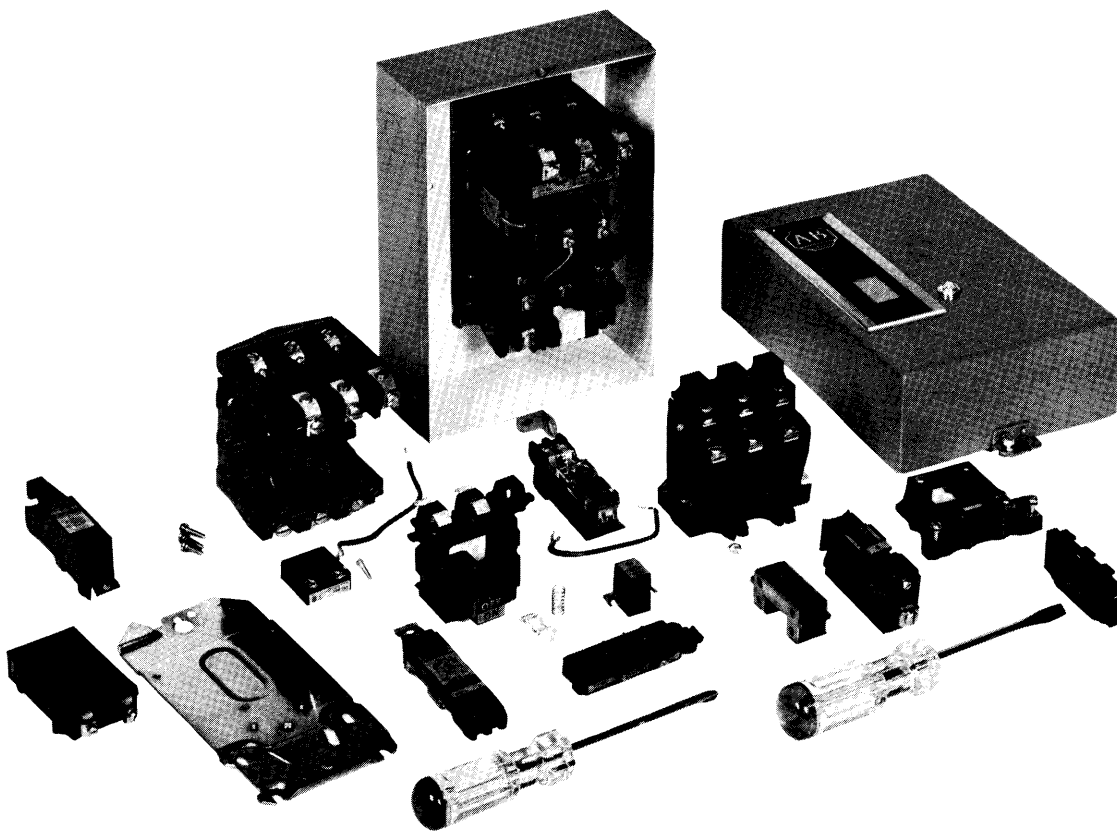

# **THE BULLETIN 509 ASSEMBLY GUIDE - Features and Benefits**

---



Allen-Bradley quality is more than a slogan. It is the sum of attention to detail at every phase of a product's design, manufacture, and delivery.

Our objective is to provide products in the best possible condition with designed-in reliability.

This Features and Benefits Assembly Guide has been prepared to assist you in understanding the value and application of each key part of the 509 starter.

## TABLE OF CONTENTS

Mounting Plate .....	3
Stationary Contact Block and Base Assembly .....	4
Movable Contact Support and Armature Assembly .....	5
Operating Coil and Yoke .....	6
Coil Cover .....	7
Arc Hood Front Cover .....	8
Overload Relays .....	9
Type "W" Heater Element .....	10
Auxiliary Contact Block (Interlock) .....	11
Control Wiring .....	12
Auxiliary Contact Block (Extra) .....	13
Control Circuit Fuse Holder .....	14
Power Pole Adder with Load Balancer .....	15
Surge Suppressor .....	16
Auxiliary Contact (N.O.) for Overload Relay .....	17
Top Wiring Kit .....	18
Enclosure .....	19

## Mounting Plate

### Features

- Heavy gauge steel
- Zinc-Chromate finish
- 3 mounting slots

### Benefits

- Absorbs mounting and operating stress to extend life of starter
- Resists corrosion, improves life
- Convenience (ease of mounting)

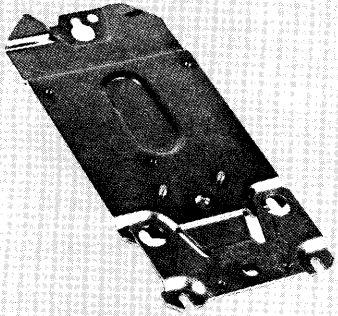

### Assembly Tips

No assembly required. Starter parts are assembled to the baseplate.

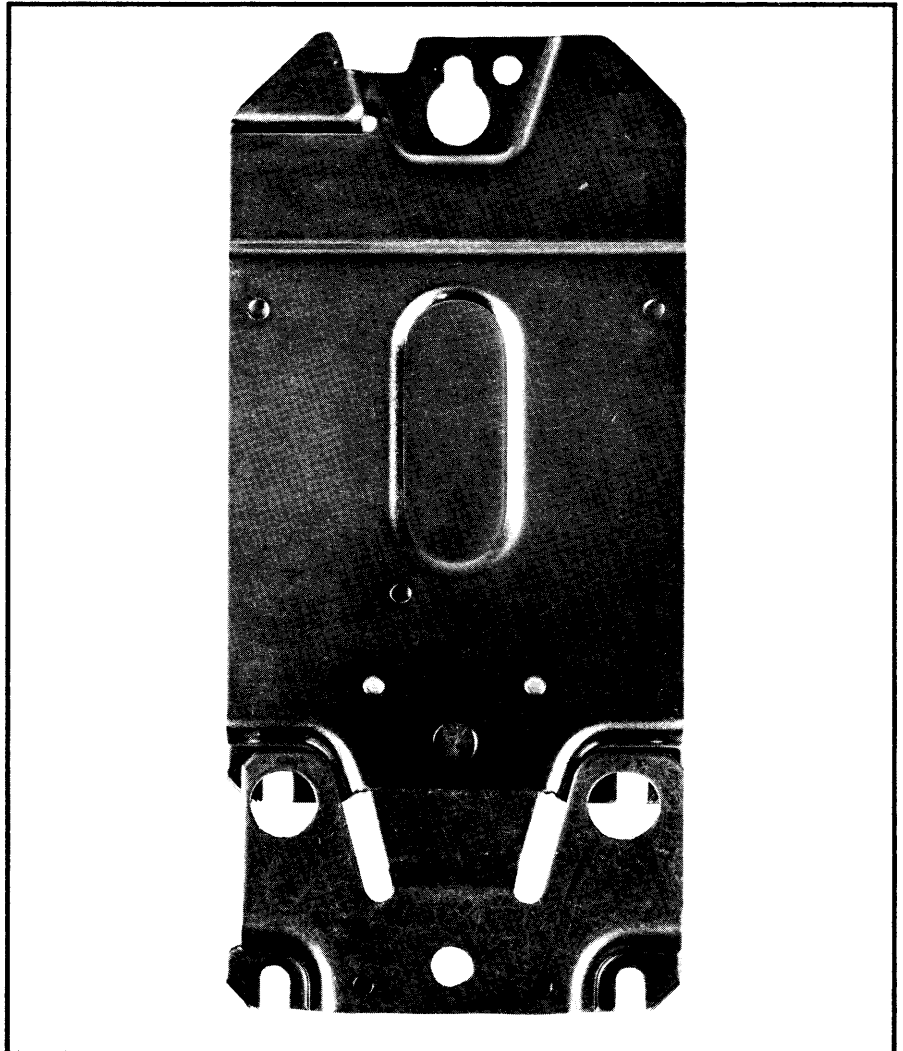

## Stationary Contact Block and Base Assembly

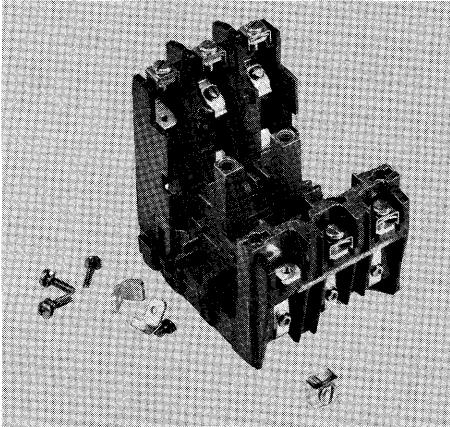

### Features

- Molded fiber reinforced polyester arc hood
- Molded fiber reinforced polyester base
- Cover screw sockets
- Steel reinforced
- Four molded pockets
- Up-front terminals
- Retractable wire clamps
- Molding around wire clamps

### Benefits

- Resists arc tracking
- Non-carbonizing, improved electrical life
- Wear resistant
- Designed for durability
- Extra mechanical strength
- Anti-pullout anchor for coil cover screws, ease of reassembly
- Ease of field mounting for auxiliary contacts
- Added flexibility
- Easier wiring
- Save time and materials
- Keeps clamps from twisting/turning
- Ease of installation

### Assembly Tips

Align the base with the three screw holes on the mounting plate. Fasten firmly with three (3) phillips head screws.

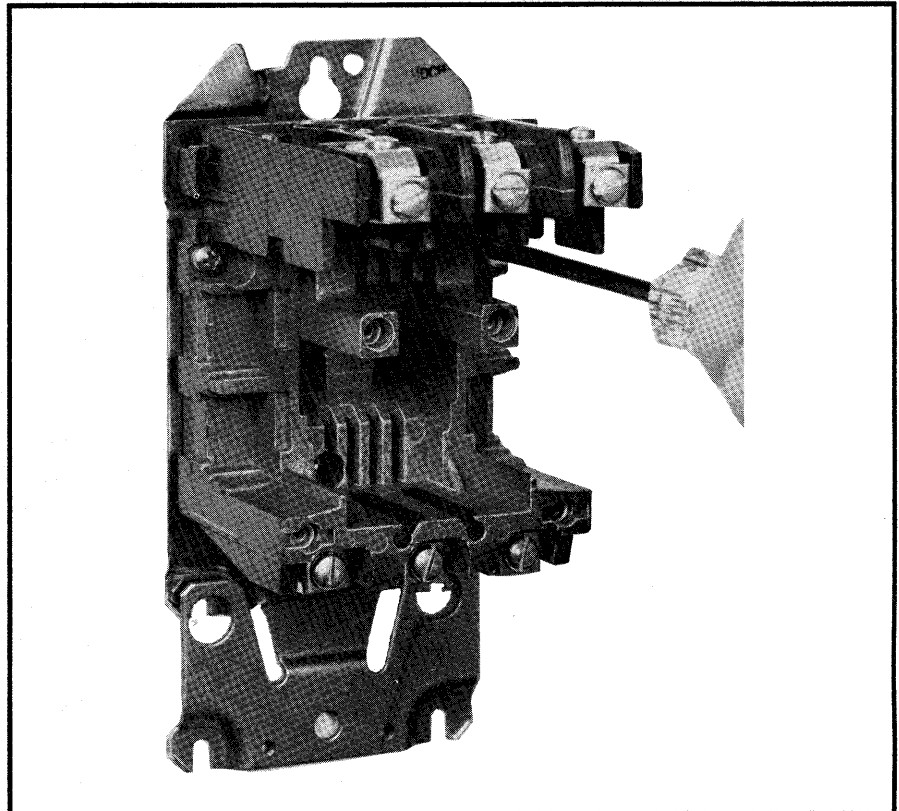

## Movable Contact Support and Armature Assembly

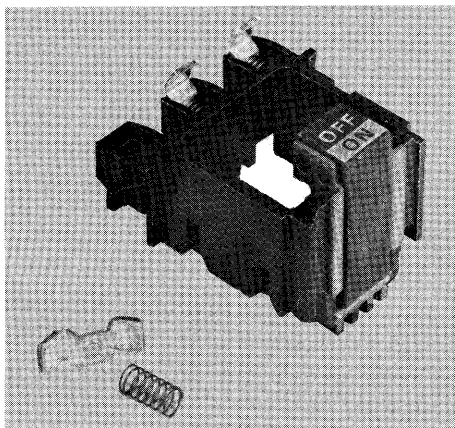

### Features

- Silver alloy  
Double break contacts
- Angled contacts
- Unique guiding design
- Contacts replaceable  
without removing power wiring.  
(Both stationary and movable  
contacts)
- Vertical lift/gravity  
Dropout

### Benefits

- Weld resistant
- Low contact erosion
- Long life and improved  
reliability
- Minimal movement
- Reduced contact wear and  
improved life
- Improved alignment leading to  
longer mechanical life
- Quicker, easier maintenance
- Less downtime
- Exceptional reliability
- Not dependent on springs, pivot  
points or linkages
- Longer mechanical life
- Less downtime

### Assembly Tips

No assembly required. Operating coil and yoke are assembled into this part, with instructions on that sheet.

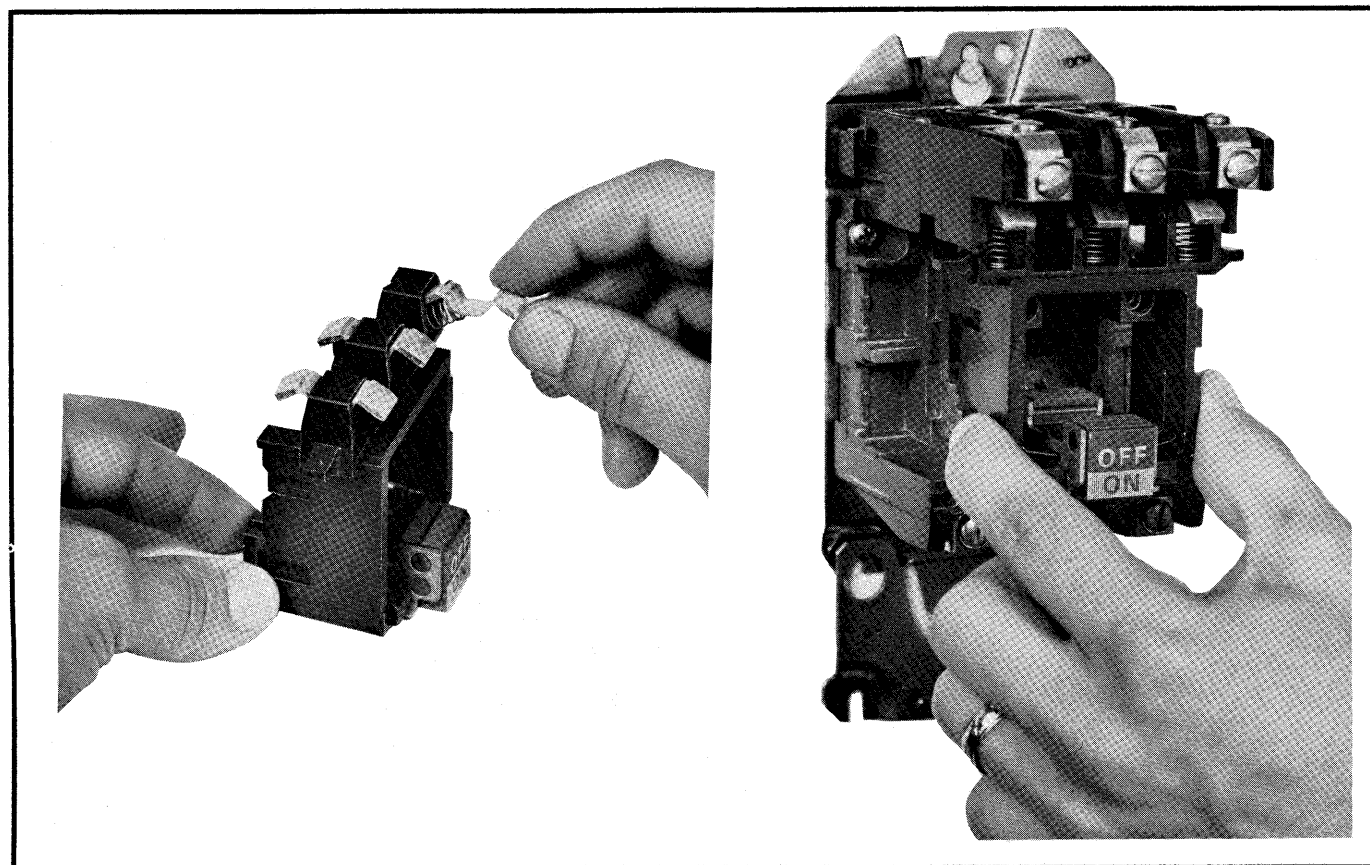

## Operating Coil and Yoke

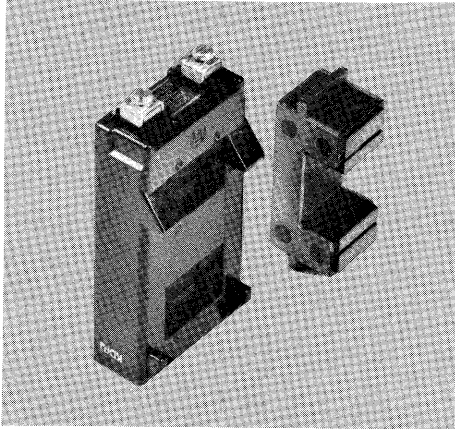

### Features

- Magnet  
Each lamination is phosphate coated, assembled and epoxy impregnated
- Short stroke
- Cushion mounting
- Permanent air gap
- Coil/magnet assemble only one way
- Hot pressure-molded coil
- Exclusive thermal cutout in coil
- Coil is color coded.  
Voltage, frequency & catalog number printed on front.

### Benefits

- Corrosion resistant, extends life, reduces maintenance cost
- Reduced impact
- Longer life
- Extended life
- Assures proper seating
- Guards against buzzing/chattering, improves reliability and ease of maintenance
- Protects windings against mechanical damage, moisture, harmful environments
- Less downtime
- Reduce downtime and maintenance costs. No damage to starter in the event of coil failure.
- Ease of identification

## Assembly Tips

Fit magnet into the two slots on top of the coil. Slide assembled coil and magnet into the movable contact support and armature assembly, directly over the on-off indicator. Slide this entire assembly into the stationary contact block and base assembly.

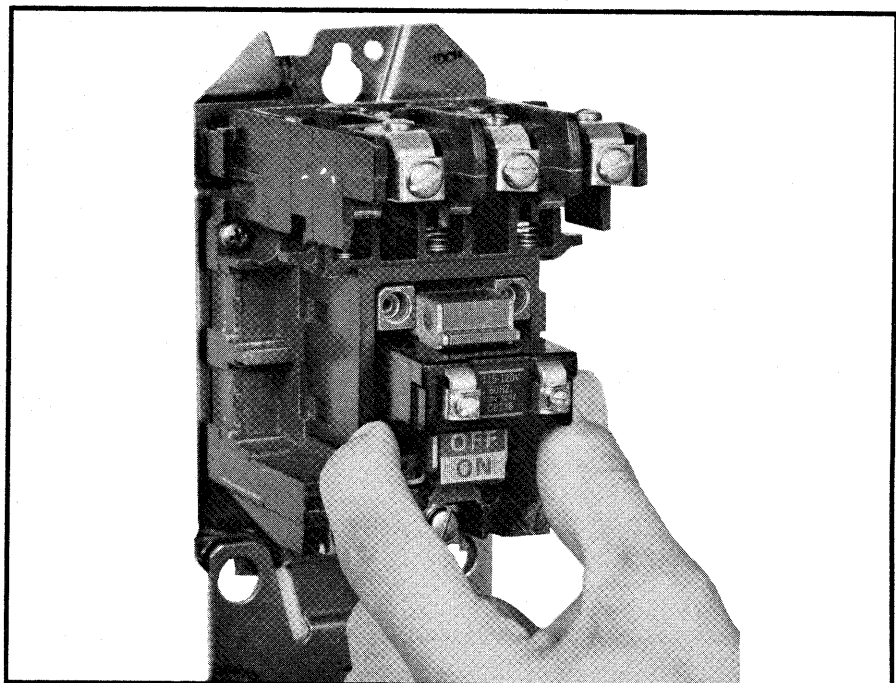

## Coil Cover

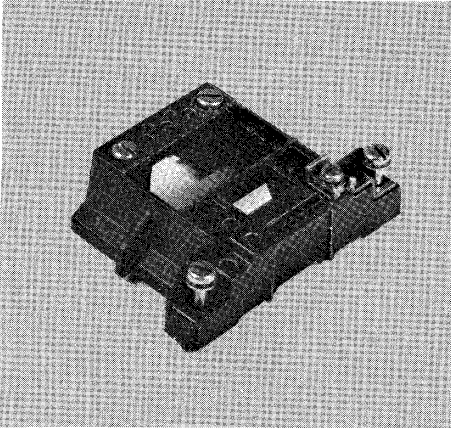

### Features

- Phenolic cover
- Four captive screws

### Benefits

- Durability and reliability for long life
- Convenience, reduced maintenance and low inspection costs, safety

## Assembly Tips

Place directly over the coil. Make sure ON-OFF indicator is visible through the smaller opening. Tighten four captive screws.

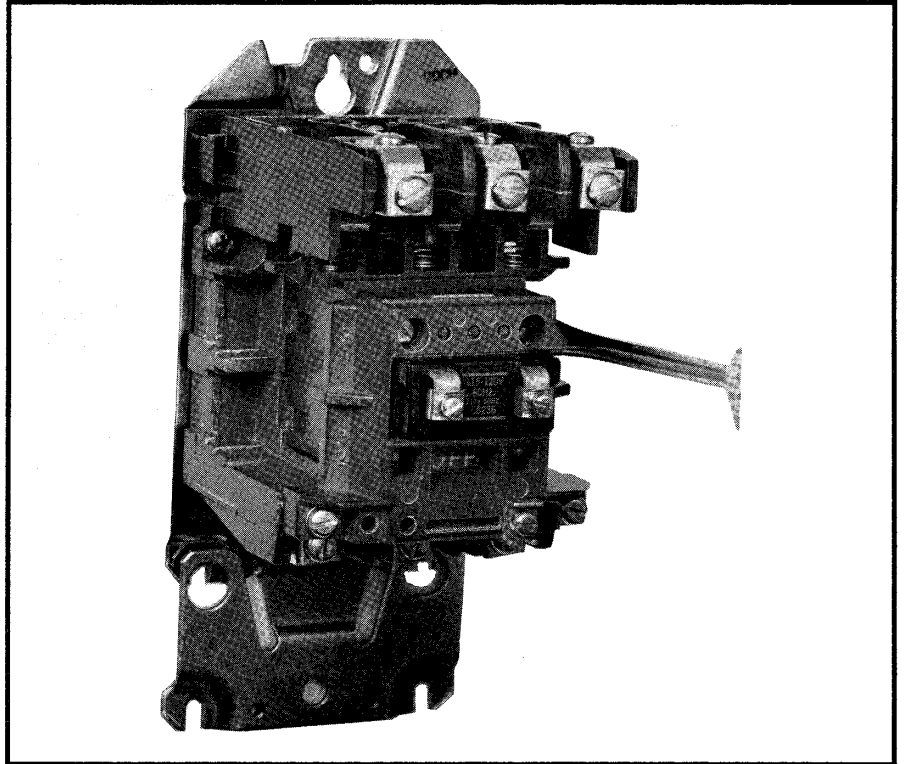

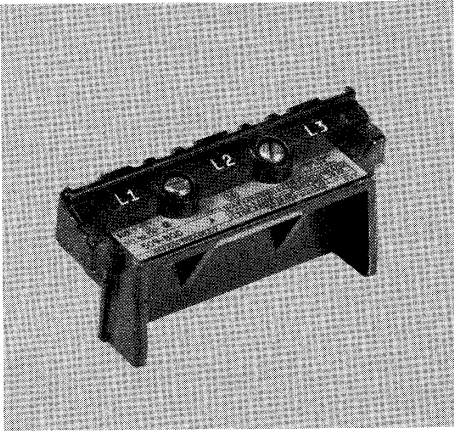
**Arc Hood Front Cover****Features**

- Molded fiber reinforced polyester
- Two captive screws
- Starter nameplate

**Benefits**

- Rugged, durable
- Convenience
- Provides maximum application ratings and device identification for easy maintenance

**Assembly Tips**

Mounts onto the base by sliding directly into the area above the coil cover. Tighten both captive screws.

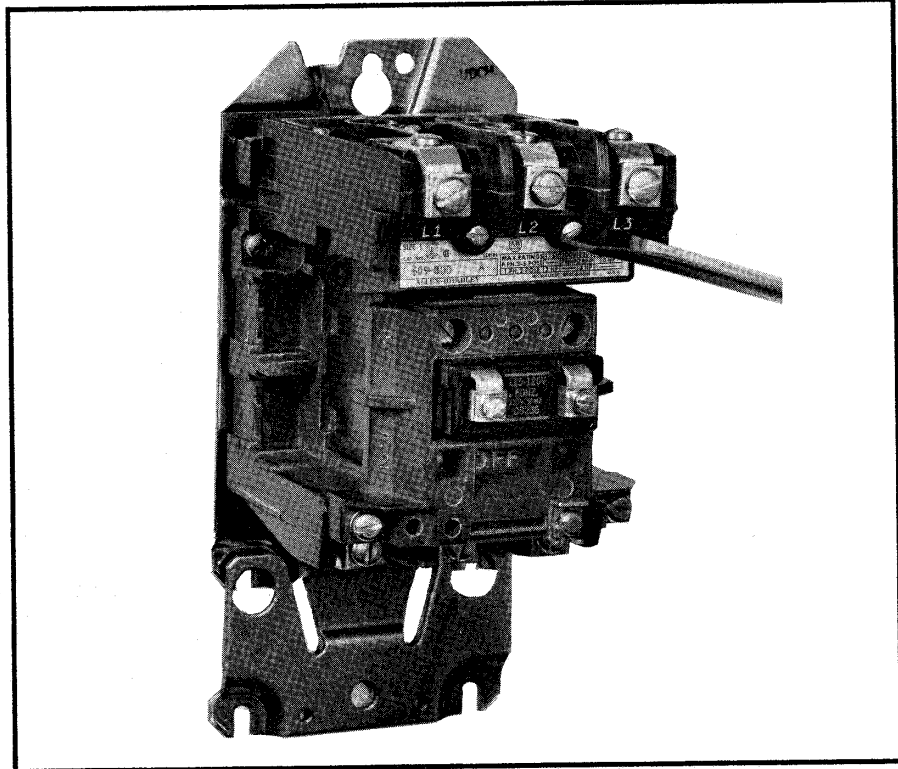

## Overload Relay

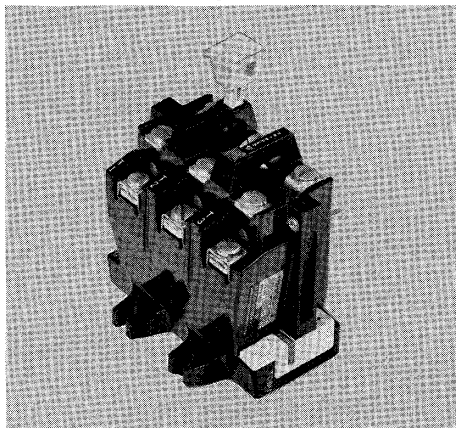

### Features

- Direct bus connection between starter mounted relay and load side of contactor
- Not convertible from manual to automatic reset
- Optical (reflecting) trip indicator
- Large light grey reset button with non-stop surface
- Shock and vibration resistant
- Trip-free operation with manual reset

### Benefits

- Improved reliability
- Space saving, narrower panel space than side mounted type
- Improved safety
- No **unexpected** automatic restarts, meets NEC requirements
- Easy to see
- Quick troubleshooting
- Less downtime
- Visibility
- Improved safety
- Improved reliability
- Less downtime
- Starter operation cannot be interrupted by pushing reset button, safer

## Assembly Tips

Loosen, but do not remove the three terminal screws at the bottom of the block and base assembly. Add the overload relay, being sure that the bus connects properly to the terminals on the contact block assembly. Secure the bottom of the overload relay to the mounting plate with the two mounting screws. Tighten securely. Now tighten the three terminal screws securely.

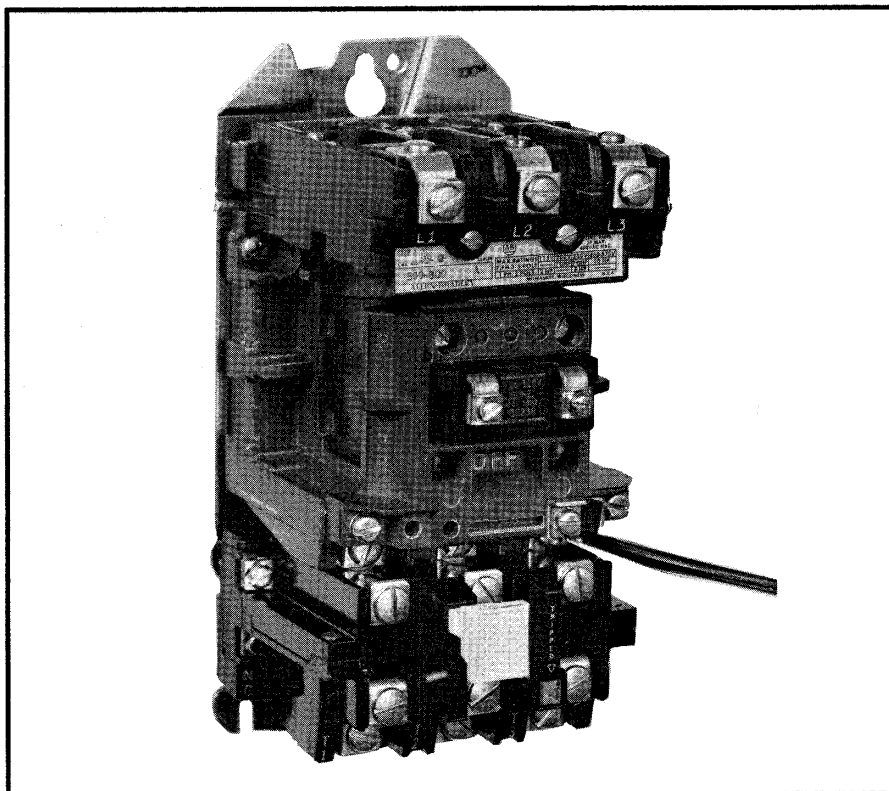

## Type "W" Heater Element

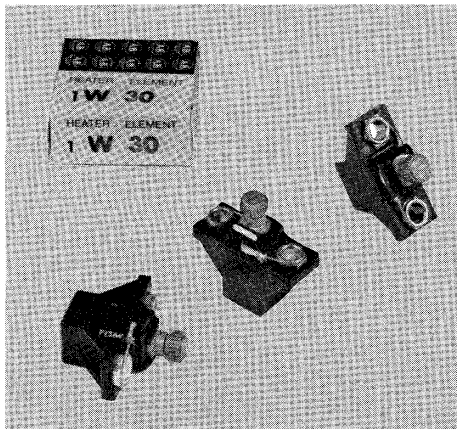

### Features

- Reduced sensitivity to ambient temperature  
Quicker tripping
- Eutectic (melting) alloy construction
- May be used in 709, Series K starters

### Benefits

- Minimized nuisance tripping and unnecessary downtime
- Better motor protection
- Less downtime
- Less repair/replacement cost
- More consistent, prompt accuracy in response to overloads
- Better protection and safer
- Reduces heater element stock, allows for standardization on Type W
- Reduced warehouse costs

### Assembly Tips

Remove the three pairs of screws on the front of the overload relay. Install the three heater elements. Reinstall and tighten screws securely.

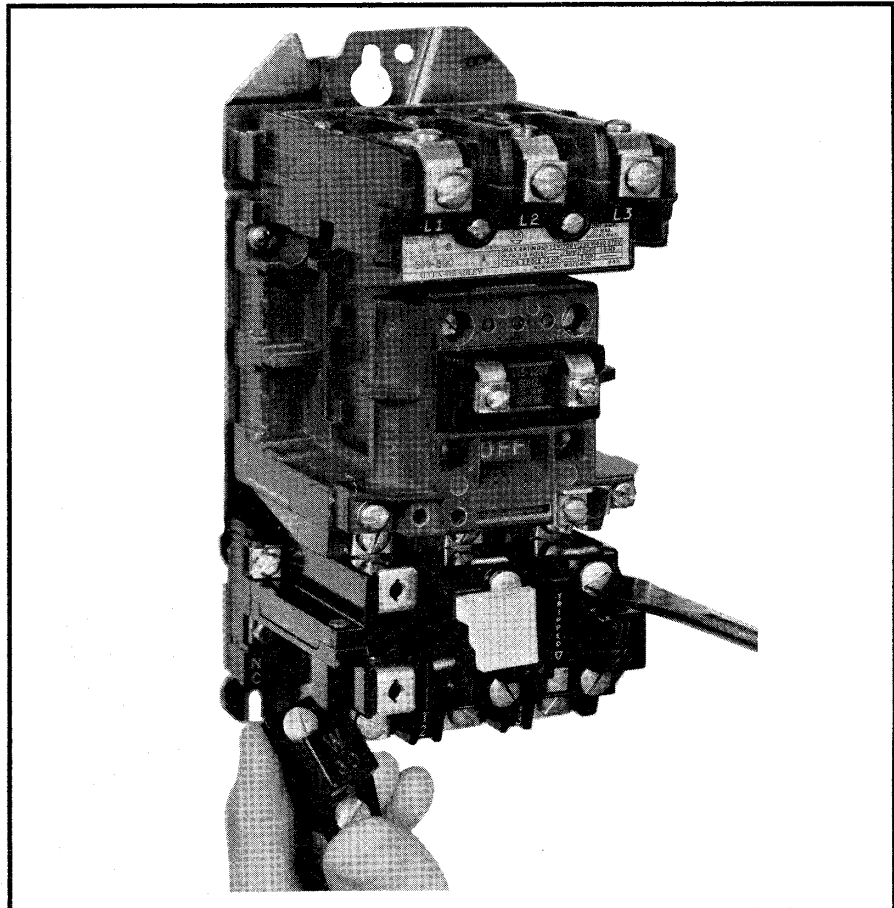

## Auxiliary Contact Block (Interlock)

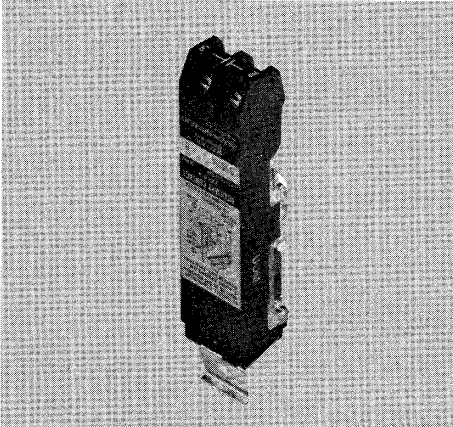

### Features

- Wire clamps
- No screws/snap in mounting
- Bifurcated contacts
- Room for up to eight auxiliary contacts (interlock and extra) possible including hold-in contact

### Benefits

- Convenient
- Eliminate need for lugging of control wires
- Low cost wiring and maintenance
- Fast, convenient
- Increased reliability
- Application flexibility and lower installation cost, lower warehousing costs
- Greater control flexibility
- Easy installation

### Assembly Tips

Push the movable contact support and armature assembly down into the "OFF" position. Align arrows molded on back side of auxiliary contact block. Locate molded tabs on the same side as the arrows. Hook tabs under coil cover at position marked "P1". Push in at the bottom until it snaps in.

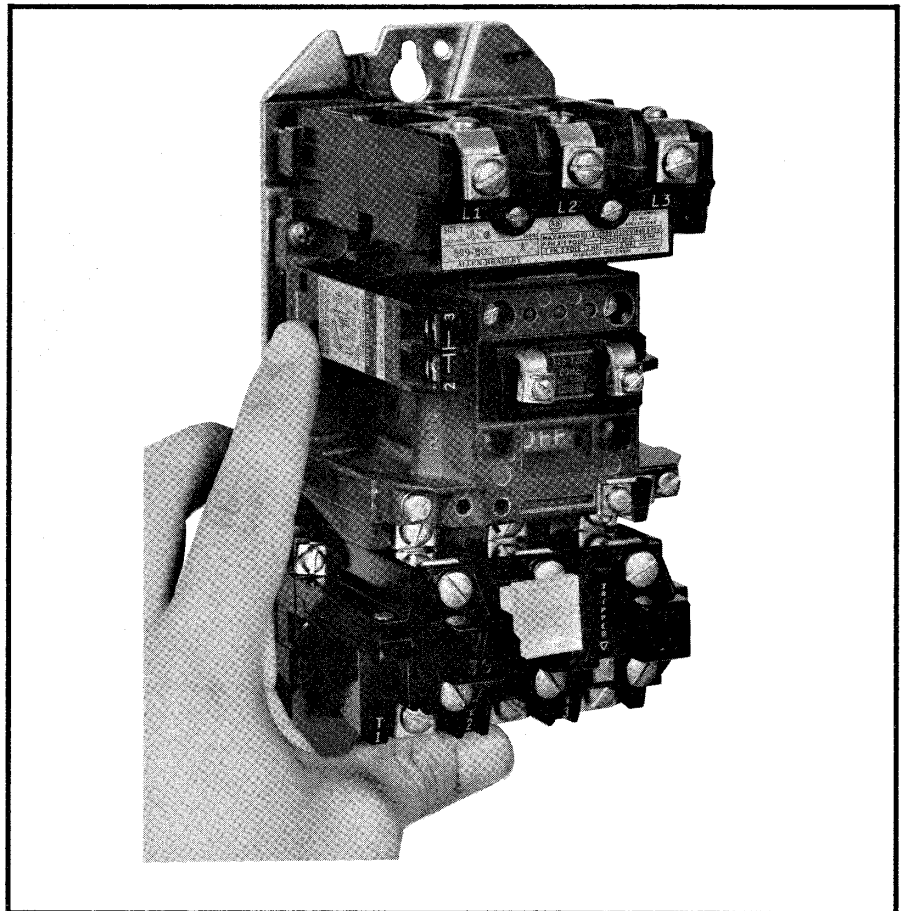

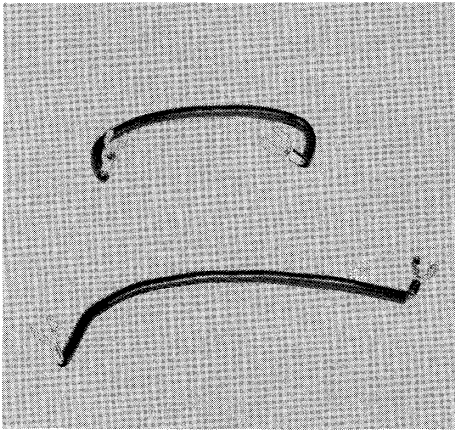
**Control Wiring****Features**

- Fork-ring type lugs
- Stranded Conductors

**Benefits**

- Wire lug may be removed by loosening, but not removing, the screws
- Wire lug will not fall out when screws are loosened
- Flexibility
- Reliability

**Assembly Tips**

Connect shorter wire from right hand terminal of coil to #3 on auxiliary contact. Connect longer wire from left hand terminal of coil to upper terminal on overload relay.

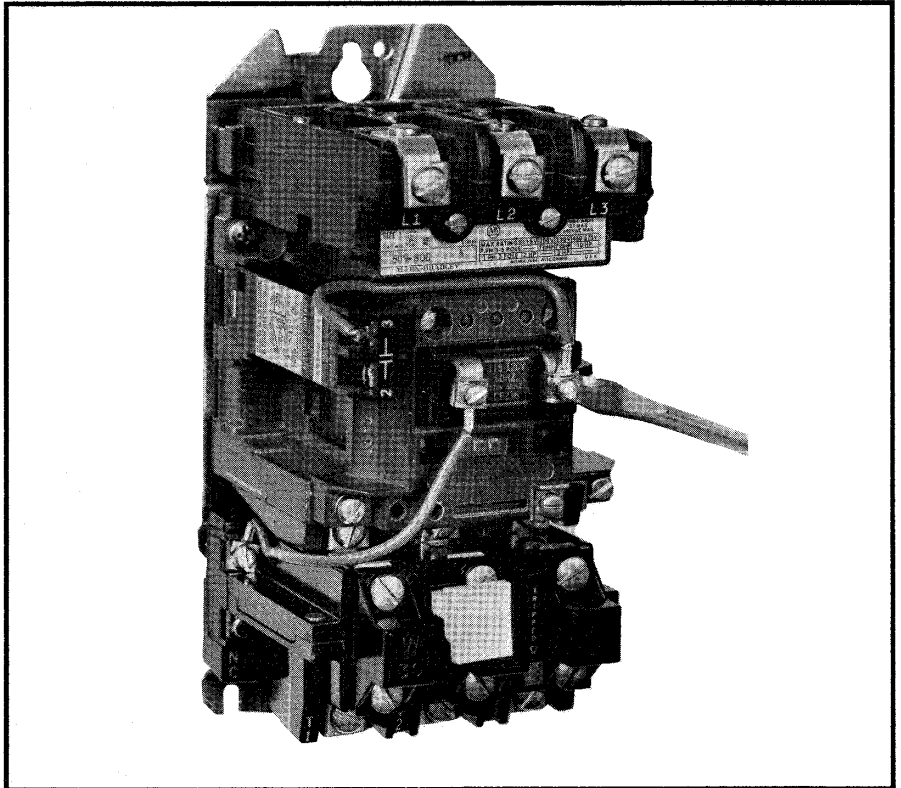

## Auxiliary Contact Block (Extra)

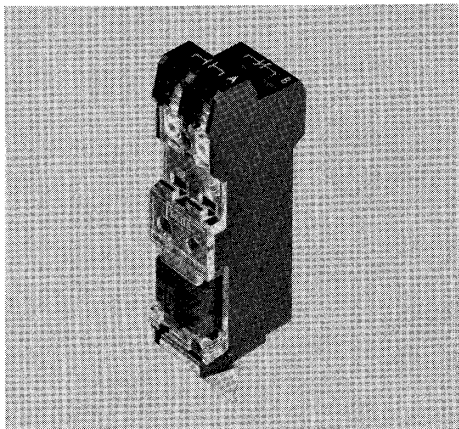

### Features

- No screws/snap-in mounting
- Bifurcated contacts
- Room for up to eight auxiliary contacts (interlock and extra) possible including hold-in contact

### Benefits

- Convenient
- Eliminate need for lugging of control wires, lower installation costs
- Fast, convenient, lower costs from vibration
- Increased reliability
- Lower installation cost
- Greater control flexibility
- Easy installation

### Assembly Tips

Push the movable contact support and armature assembly down into the "OFF" position. Align arrows molded on back side of auxiliary contact block. Locate molded tabs on the same side as the arrows. Hook tabs under coil cover at any open position (P2, P3 or P4). Push in at the bottom until it snaps in.

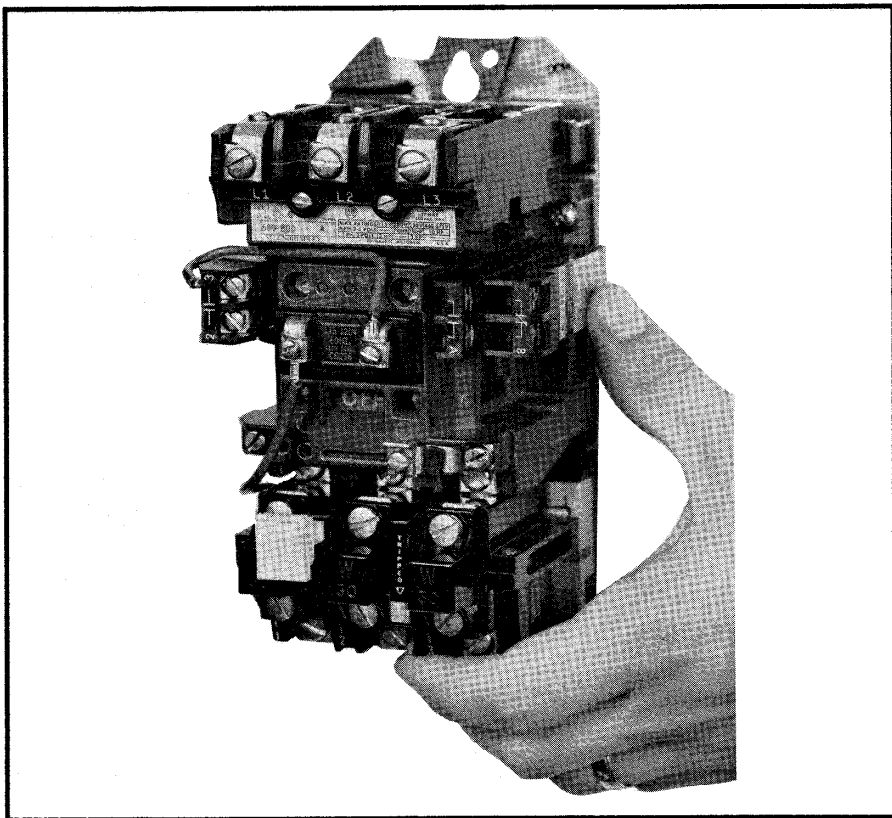

## Control Circuit Fuse Holder

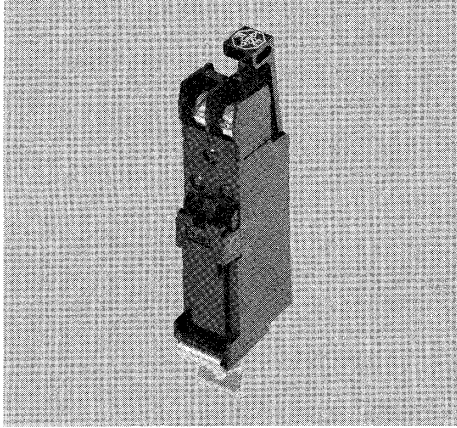

### Features

- Snap-in mounting
- Alternate panel mounting possible

### Benefits

- Easy, time saving
- Added flexibility
- Easy way to provide control circuit protection

### Assembly Tips

Fuseholder mounts in auxiliary pocket on controller. First insert spring clip into slot in fuseholder. Hook tabs under coil cover and push bottom of fuseholder into controller base until the spring clip snaps in place.

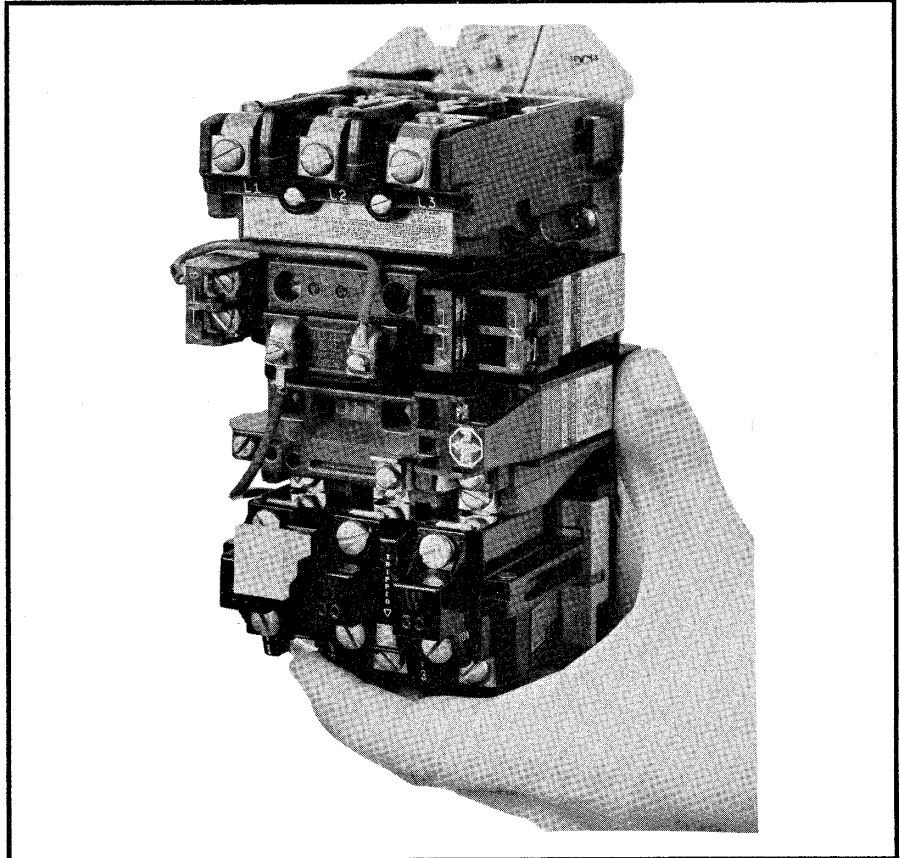

## Power Pole Adder With Load Balancer

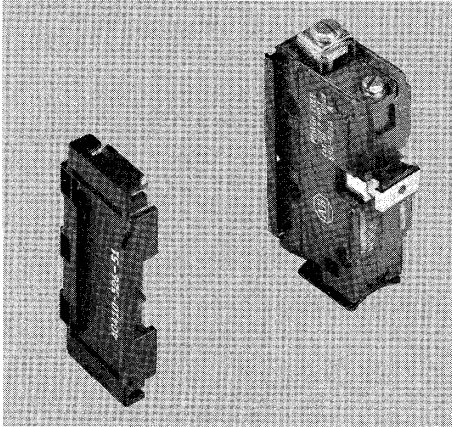

### Features

- Field addable
- One or two may be added
- Load balancer

### Benefits

- Convenience
- Flexibility
- Versatility
- Evens load on armature extending mechanical life

### Assembly Tips

#### Power Pole

Remove arc hood front cover. Movable contact support of the contactor must be in the down (off) position.

Hold the adder pole front forward (with lugs facing front) along the side of the arc hood.

Fit the sharp edge of the top of the adder pole into the groove along the top of the arc hood. Now push the adder pole back as far as possible and snap it in at the bottom. Be sure that the projection on the movable contact support mates with the corresponding slot in the power pole adder.

#### Load Balancer

To be installed opposite the power pole adder – on the other side of the arc hood. Hook the three projections at the top on the groove in the arc hood. Now push the load balancer back as far as possible and snap it in at the bottom.

**Note:** No Load Balancer needed when two power pole adders are installed.

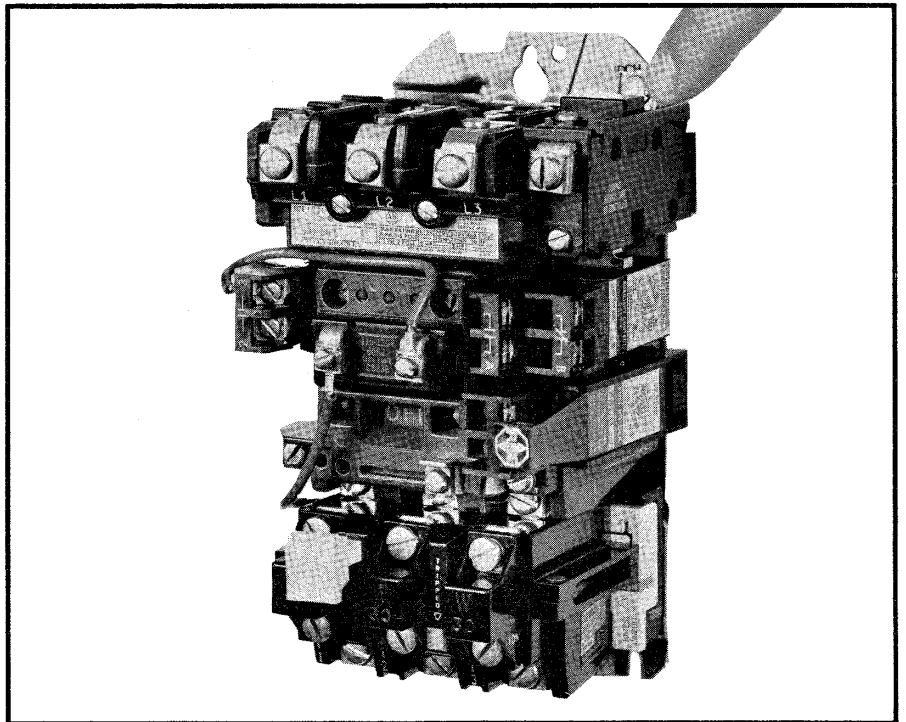

## Surge Suppressor

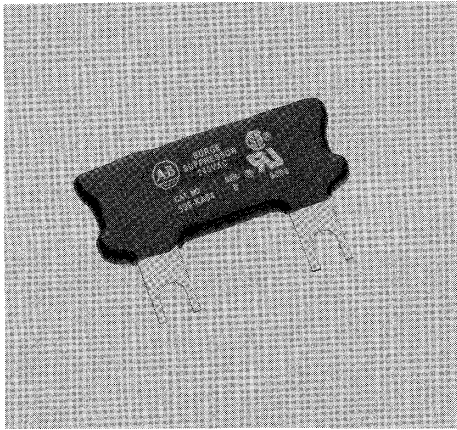

### Features

- Field addable
- Mounts directly on coil terminals

### Benefits

- Convenient
- Space saving
- Easy installation
- Provides protection for solid state logic

### Assembly Tips

Loosen coil terminal clamps. Slide surge suppressor onto coil terminals from top of switch. Place coil circuit conductors between surge suppressor terminals and coil terminal clamps. Tighten coil terminal clamps.

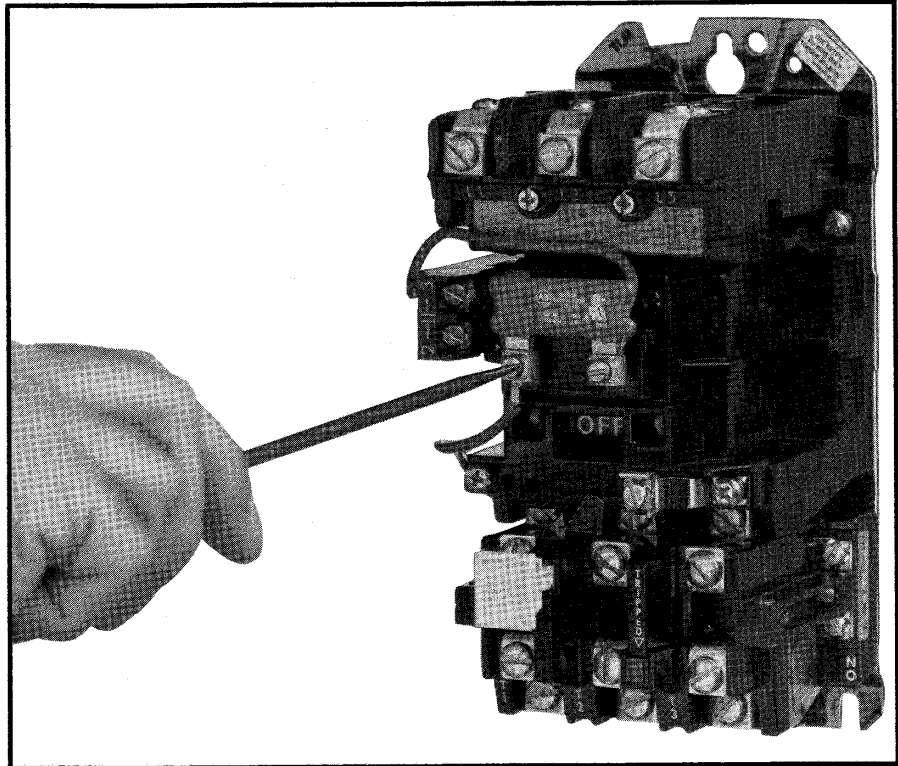

**Auxiliary Contact (N.O.)  
For Overload Relay**

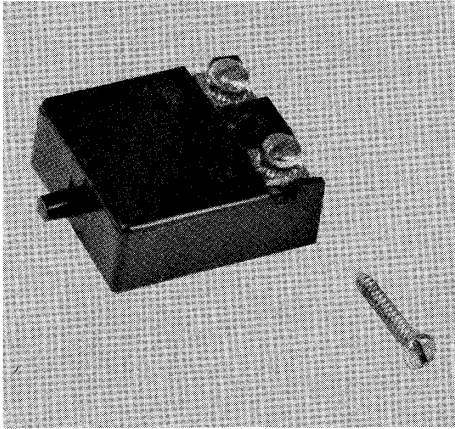

**Features**

- Field addable

**Benefits**

- Convenient, application flexibility saves time and reduces cost

**Assembly Tips**

Insert screwdriver into slot in circuit tester, depress retainer arm and slide circuit tester out to the right. Slide contact assembly into the overcurrent relay with catalog numbers facing out. Screws should be pointing towards the front of the assembly. Secure the block using the mounting screw in hold provided.

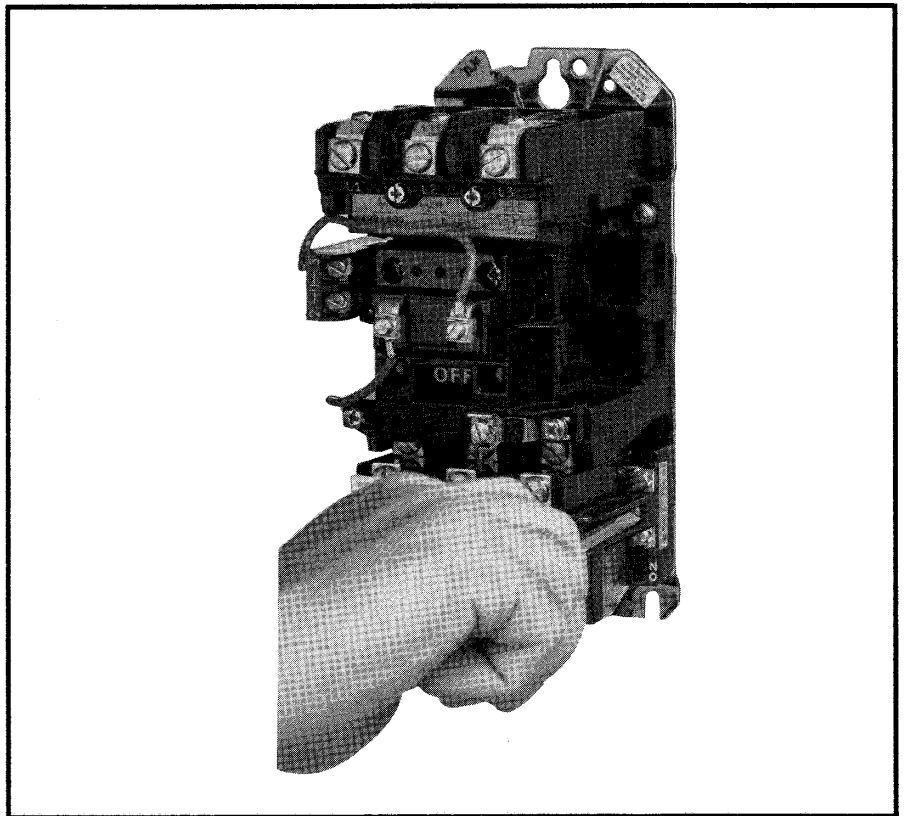

## Top Wiring Kit

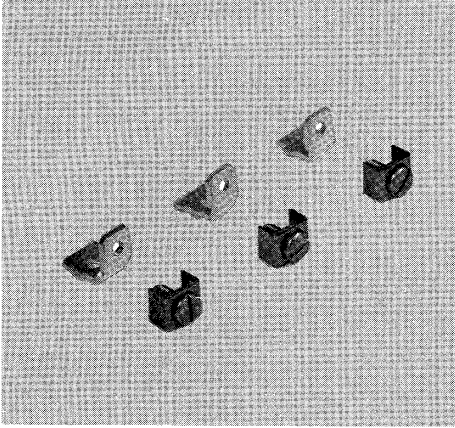

### Features

- Can be added to any through-wired contactor or starter

### Benefits

- Application versatility
- Allows for easy addition of power factor correction capacitors without resizing of heater elements
- Allows for control of second motor with addition of block overload relay

### Assembly Tips

Remove the screws from the rear stationary terminals. Place the wiring terminal in its location so that the wiring terminal lays flat. Inset the screw through the wiring terminal and fasten securely.

**Important:** Size 3 and 4 terminals are designed to be mounted at a slight angle.

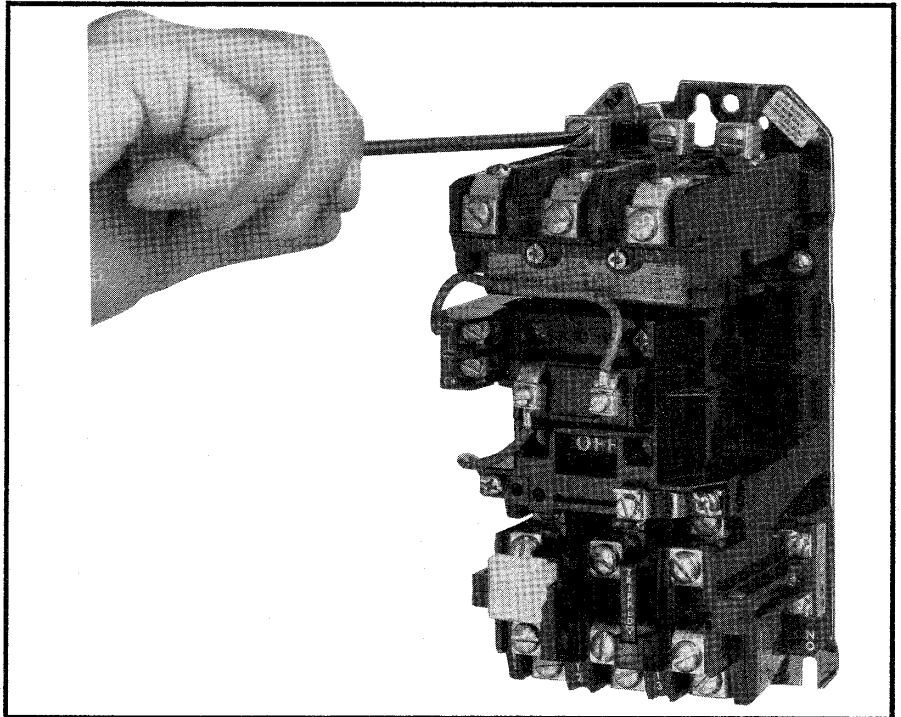

## Enclosure

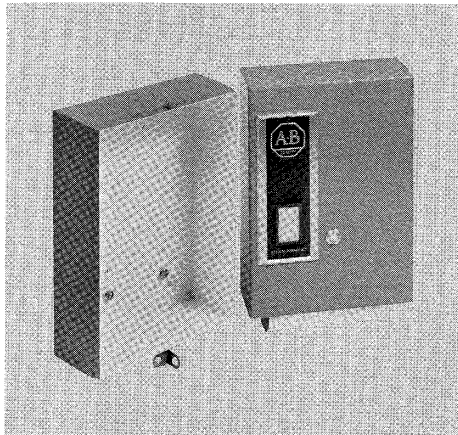

### Features

- Electro-deposition painting process
- Cleaning
- Phosphating
- Primer
- Baked enamel
- Shallow enclosure base
- All unpainted parts plated
- Three-point mounting
- Ample wiring room
- 1/4 turn faster
- Padlock provision
- All knockouts removed by the factory and replaced
- Picture frame
- Knockout

### Benefits

- Corrosion resistant
- Longer life
- Better value
- Neat appearance
- Higher visibility
- Eases installation
- Reduces installation costs
- Eases wiring
- Better value
- Convenient
- Corrosion resistant, greater reliability
- Convenience
- Time and cost saving
- Convenience
- Time saving
- Convenient, secure
- Added safety, security
- Easy, low cost installation field removal
- Convenient for mounting selector switches or push buttons

### Assembly Tips

Loosely mount two screws on lower inside panel. Hang starter on these screws, use mounting slots on bottom of base plate. Align holes and insert top screw. Tighten all three.

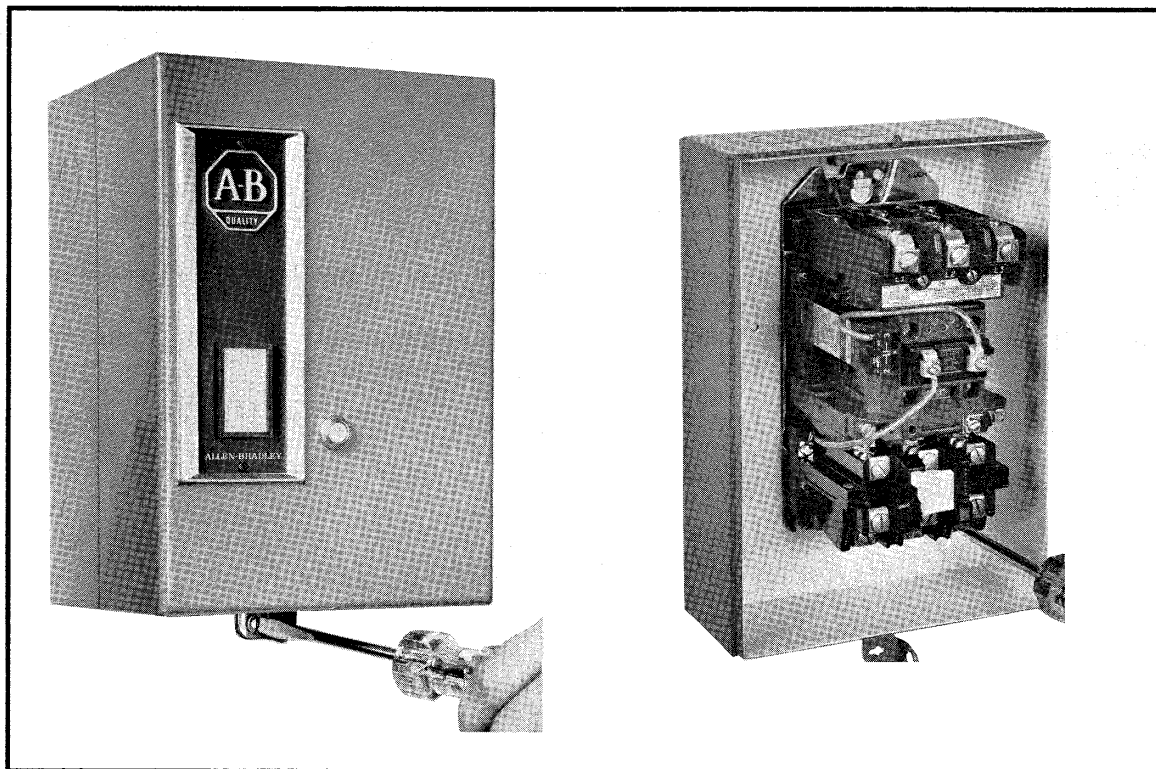



**ALLEN-BRADLEY**  
A ROCKWELL INTERNATIONAL COMPANY

With offices in major cities worldwide.

---

**WORLD HEADQUARTERS**  
1201 South Second Street  
Milwaukee, WI 53204 USA  
Tel: (414)382-2000  
Telex: 43 11 016  
FAX: (414)382-4444

**EUROPE/MIDDLE EAST/  
AFRICA HEADQUARTERS**  
Allen-Bradley Europe B.V.  
Amsterdamseweg 15  
1422 AC Uithoorn  
The Netherlands  
Tel: (31)2975/43500  
Telex: (544) 18042  
FAX: (31)2975/60222

**ASIA/PACIFIC HEADQUARTERS**  
Allen-Bradley (Hong Kong) Limited  
2901 Great Eagle Center  
23 Harbour Road  
G.P.O. Box 9797  
Wanchai, Hong Kong  
Tel: (852)/573-9391  
Telex: (780) 64347  
FAX: (852)/834-5162

**CANADA HEADQUARTERS**  
Allen-Bradley Canada Limited  
135 Dundas Street  
Cambridge, Ontario N1R 5X1  
Canada  
Tel: (519)623-1810  
Telex: (069) 59317  
FAX: (519)623-8930

**LATIN AMERICA  
HEADQUARTERS**  
1201 South Second Street  
Milwaukee, WI 53204 USA  
Tel: (414)382-2000  
Telex: 43 11 016  
FAX: (414)382-2400