

# 1769 Compact I/O Modules Specifications

## Catalog Numbers

Digital I/O Modules	1769-IA8I, 1769-IA8IK, 1769-IA16, 1769-IA16K, 1769-IM12, 1769-OA8, 1769-OA16, 1769-OA16K, 1769-IG16, 1769-IQ16, 1769-IQ16K, 1769-IQ16F, 1769-IQ32, 1769-IQ32K, 1769-IQ32T, 1769-IQ6XOW4, 1769-OB8, 1769-OB8K, 1769-OB16, 1769-OB16K, 1769-OB16P, 1769-OB32, 1769-OB32K, 1769-OB32T, 1769-OG16, 1769-OV16, 1769-OV32T
Contact I/O Modules	1769-OW8, 1769-OW8I, 1769-OW8IK, 1769-OW16, 1769-OW16K
Analog I/O Modules	1769-IF4, 1F4K, 1769-IF4I, 1769-IF4XOF2, 1769-IF4XOF2K, 1769-IF4FXOF2F, 1769-IF8, 1769-IF8K, 1769-IF16C, 1769-IF16V, 1769-IR6, 1769-IT6, 1769-OF2, 1769-OF2K, 1769-OF4, 1769-OF4K, 1769-OF4CI, 1769-OF4VI, 1769-OF8C, 1769-OF8V
Specialty Modules	1769-ARM, 1769-ASCII, 1769-BOOLEAN, 1769-HSC, 1769-SM2
Accessories	1769-ECL, 1769-ECLK, 1769-ECR, 1769-ECRK, 1769-ECL, 1769-ECLK, 1769-ECR, 1769-ECRK, 1769-CLL1, 1769-CRR1, 1769-CRL1, 1769-CLL3, 1769-CRR3, 1769-CRL3

Topic	Page
Summary of Changes	2
I/O Module Overview	2
Environmental Specifications	2
Certifications	3
Place Compact I/O Modules	4
Digital I/O Modules	5
Contact I/O Modules	25
Analog I/O Modules	29
Specialty I/O Modules	53
Compact I/O Mounting Dimensions	61
Compact I/O Accessories	61
Wiring Systems	64
Additional Resources	65

The 1769 Compact I/O™ modules can be used in these applications:

- With a 1769 CompactLogix™ controller
- For expansion I/O in a MicroLogix™ 1500 controller assembly
- In an assembly with a 1769-ADN DeviceNet® adapter
- In an assembly with a 1769-AENTR Ethernet adapter

Unless connected to a MicroLogix 1500 base, each bank of I/O modules must include its own power supply.

Install the I/O modules on a panel with two mounting screws or on a DIN rail. The modules mechanically lock together with a tongue-and-groove design and have an integrated communication bus that is connected from module to module by a movable bus connector.

## Summary of Changes

This publication contains the following new or updated information. This list includes substantive updates only and is not intended to reflect all changes.

Topic	Page
Added modules: 1769-IA16K, 1769-IA81K, 1769-IF4K, 1769-IF4XOF2K, 1769-IF8K, 1769-IQ16K, 1769-IQ32K, 1769-OA16K, 1769-OB16K, 1769-OB32K, 1769-OB8K, 1769-OF2K, 1769-OF4K, 1769-OW16K, 1769-OW81K, 1769-SM2	Throughout
Updated certifications	3

## I/O Module Overview

Each I/O module includes a built-in removable terminal block with fingersafe cover for connections to I/O sensors and actuators. The terminal block is behind a door at the front of the module. I/O wiring can be routed from beneath the module to the I/O terminals.

- Once the modules are locked together, the system becomes a rugged assembly.
- Upper and lower tongue-and-groove slots guide the module during installation and attach the module to the system.
- Removable terminal blocks help ease the wiring task.
- Self-lifting, field-wire pressure plates cut installation time.
- The patented bus connector with the lock function enables consistent and system communication.
- A color bar is provided on the front of the module.
- Digital and field circuits are optically isolated.

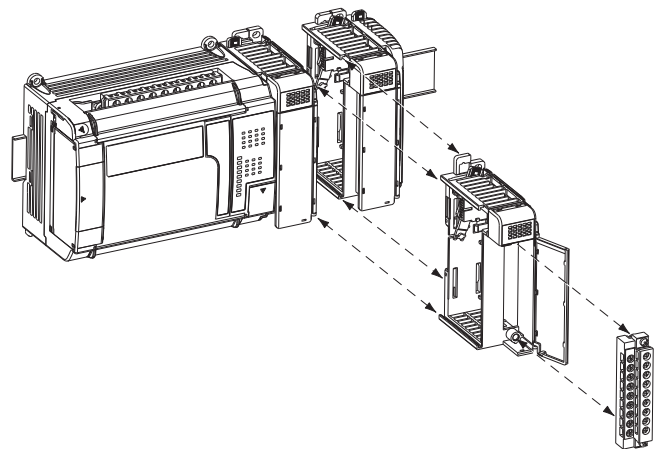

## Environmental Specifications<sup>(1)</sup>

Attribute	1769-IA81, 1769-IA81K, 1769-IA16, 1769-IA16K, 1769-IF4, 1769-IF4K, 1769-IF4XOF2, 1769-IF4XOF2K, 1769-IM12, 1769-IQ16, 1769-IQ16K, 1769-IQ16F, 1769-IQ32, 1769-IQ32K, 1769-IQ6XOW4, 1769-IR6, 1769-IT6, 1769-OA8, 1769-OA16, 1769-OA16K, 1769-OB8, 1769-OB8K, 1769-OB16, 1769-OB16K, 1769-OB16P, 1769-OB32, 1769-OB32K, 1769-OV16, 1769-OW8, 1769-OW81, 1769-OW81K, 1769-OW16, 1769-OW16K, 1769-ARM, 1756-HSC	1769-IG16, 1769-IF4FXOF2F, 1769-IF4I, 1769-IF8, 1769-IF8K, 1769-IF16C, 1769-IF16V, 1769-IQ32T, 1769-OB32T, 1769-OG16, 1769-OV32T, 1769-OF2, 1769-OF2K, 1769-OF4, 1769-OF4K, 1769-OF4CI, 1769-OF4VI, 1769-OF8C, 1769-OF8V, 1769-ASCII, 1769-BOOLEAN
Temperature, operating IEC 60068-2-1 (Test Ad, Operating Cold), IEC 60068-2-2 (Test Bd, Operating Dry Heat), IEC 60068-2-14 (Test Nb, Operating Thermal Shock)	0...60 °C (32...140 °F)	
Temperature, nonoperating IEC 60068-2-1 (Test Allen-Bradley®, Unpackaged Nonoperating Cold), IEC 60068-2-2 (Test Bb, Unpackaged Nonoperating Dry Heat), IEC 60068-2-14 (Test Na, Unpackaged Nonoperating Thermal Shock)	-40...+85 °C (-40...+185 °F)	
Relative humidity IEC 60068-2-30 (Test Db, Unpackaged Nonoperating Damp Heat)	5...95% noncondensing	
Vibration IEC 60068-2-6 (Test Fc, Operating)	Operating: 5 g @ 10...500 Hz Relay operating: 2 g	5 g @ 10...500 Hz
Shock, operating IEC 60068-2-27 (Test Ea, Unpackaged Shock)	Panel mount 30 g DIN rail mount 20 g	
Shock, relay operating IEC 60068-2-27 (Test Ea, Unpackaged Shock)	Panel mount 7.5 g DIN rail mount 5 g	—
Shock, nonoperating IEC 60068-2-27 (Test Ea, Unpackaged Shock)	Panel mount 40 g DIN rail mount 30 g	

(1) Environmental Specifications for the 1769-SM2 module are found on page 60.

# Certifications

## Certifications - 1769 Compact I/O Digital and Contact Modules

Certification <sup>(1)</sup>	1769-IA8I, 1769-IA8IK, 1769-IA16, 1769-IA16K, 1769-OA8, 1769-OA16, 1769-OA16K, 1769-OW8, 1769-OW8I, 1769-OW8IK, 1769-OW16, 1769-OW16K	1769-IM12, 1769-IQ6XOW4	1769-IG16, 1769-IQ16, 1769-IQ16K, 1769-IQ16F, 1769-IQ32, 1769-IQ32K, 1769-IQ32T, 1769-OB8, 1769-OB8K, 1769-OB16, 1769-OB16K, 1769-OB16P, 1769-OB32, 1769-OB32K, 1769-OB32T, 1769-OG16, 1769-OV16, 1769-OV32T
c-UL-us	UL Listed for Class I, Division 2 Group A,B,C,D Hazardous Locations, certified for U.S. and Canada. See UL File E334470.		
UKCA and CE	UK Statutory Instrument 2016 No. 1101 and European Union 2014/35/EU LVD Directive, compliant with: EN 61131-2; Programmable Controllers (pertinent LVD sections only)  UK Statutory Instrument 2016 No. 1091 and European Union 2014/30/EU EMC Directive, compliant with: EN 61000-6-2; Industrial Immunity EN 61000-6-4; Industrial Emissions  UK Statutory Instrument 2012 No. 3032 and European Union 2011/65/EU RoHS Directive, compliant with: EN IEC 63000; Technical Documentation		UK Statutory Instrument 2016 No. 1091 and European Union 2014/30/EU EMC Directive, compliant with: EN 61000-6-2; Industrial Immunity EN 61000-6-4; Industrial Emissions  UK Statutory Instrument 2012 No. 3032 and European Union 2011/65/EU RoHS, compliant with: EN IEC 63000; Technical Documentation
RCM	Australian Radiocommunications Act, compliant with: EN 61000-6-4; Industrial Emissions		
KC	Korean Registration of Broadcasting and Communications Equipment, compliant with: Article 58-2 of Radio Waves Act, Clause 3		
Morocco	Arrêté ministériel n° 6404-15 du 1er muharram 1437 Arrêté ministériel n° 6404-15 du 29 ramadan 1436		

(1) When marked. See the Product Certification link at [rok.auto/certifications](http://rok.auto/certifications) for Declarations of Conformity, Certificates, and other certification details.

## Certifications - 1769 Compact I/O Analog Modules

Certification <sup>(1)</sup>	1769-IF4, 1769-IF4K, 1769-IF4XOF2, 1769-IF4XOF2K, 1769-IF4FXOF2F, 1769-IF8, 1769-IF8K, 1769-OF2, 1769-OF2K	1769-IF4I, 1769-IT6, 1769-OF4CI, 1769-OF4VI, 1769-OF8C, 1769-OF8V	1769-IF16C, 1769-IF16V	1769-IR6	1769-OF4, 1769-OF4K
c-UL-us	UL Listed for Class I, Division 2 Group A,B,C,D Hazardous Locations, certified for U.S. and Canada. See UL File E334470.	UL Listed Industrial Control Equipment, certified for US and Canada. See UL File E65584. UL Listed for Class I, Division 2 Group A,B,C,D Hazardous Locations, certified for U.S. and Canada. See UL File E194810.	UL Listed Industrial Control Equipment, certified for US and Canada. See UL File E10314. UL Listed for Class I, Division 2 Group A,B,C,D Hazardous Locations, certified for U.S. and Canada. See UL File E10314.	UL Listed for Class I, Division 2 Group A,B,C,D Hazardous Locations, certified for U.S. and Canada. See UL File E194810.	UL Listed Industrial Control Equipment, certified for US and Canada. See UL File E322657. UL Listed for Class I, Division 2 Group A,B,C,D Hazardous Locations, certified for U.S. and Canada. See UL File E334470.
UKCA and CE	UK Statutory Instrument 2016 No. 1091 and European Union 2014/30/EU EMC Directive, compliant with: EN 61000-6-2; Industrial Immunity EN 61000-6-4; Industrial Emissions  UK Statutory Instrument 2012 No. 3032 and European Union 2011/65/EU RoHS, compliant with: EN IEC 63000; Technical documentation				
RCM	Australian Radiocommunications Act, compliant with: EN 61000-6-4; Industrial Emissions				
KC	Korean Registration of Broadcasting and Communications Equipment, compliant with: Article 58-2 of Radio Waves Act, Clause 3				
Morocco	Arrêté ministériel n° 6404-15 du 1er muharram 1437 Arrêté ministériel n° 6404-15 du 29 ramadan 1436				

(1) When marked. See the Product Certification link at [rok.auto/certifications](http://rok.auto/certifications) for Declarations of Conformity, Certificates, and other certification details.

## Certifications - Specialty Modules

Certification <sup>(1)</sup>	1769-ARM, 1769-ASCII, 1769-BOOLEAN	1769-HSC	1769-SM2 <sup>(2)(3)</sup>
c-UL-us	UL Listed for Class I, Division 2 Group A,B,C,D Hazardous Locations, certified for U.S. and Canada. See UL File E334470.	UL Listed Industrial Control Equipment, certified for US and Canada. See UL File E322657. UL Listed for Class I, Division 2 Group A,B,C,D Hazardous Locations, certified for U.S. and Canada. See UL File E334470.	UL Listed Industrial Control Equipment, certified for US and Canada. See UL File E59272.
UKCA and CE	UK Statutory Instrument 2016 No. 1091 and European Union 2014/30/EU EMC Directive, compliant with: EN 61000-6-2; Industrial Immunity EN 61000-6-4; Industrial Emissions  UK Statutory Instrument 2012 No. 3032 and European Union 2011/65/EU RoHS, compliant with: EN IEC 63000; Technical documentation		
RCM	Australian Radiocommunications Act, compliant with: EN 61000-6-4; Industrial Emissions		
KC	Korean Registration of Broadcasting and Communications Equipment, compliant with: Article 58-2 of Radio Waves Act, Clause 3		
Morocco	Arrêté ministériel n° 6404-15 du 1er muharram 1437 Arrêté ministériel n° 6404-15 du 29 ramadan 1436		

(1) When marked. See the Product Certification link at [rok.auto/certifications](http://rok.auto/certifications) for Declarations of Conformity, Certificates, and other certification details.

(2) In a domestic environment, this product can cause radio interference in which case supplementary mitigation measures can be required.

(3) To remain CE, a ferrite core (Fair-Rite part number 2643102002) must be added to DSI communication cables longer than 10 m (33 ft.), and the core must be attached within 305 mm (12 in.) of the 1769-SM2 module.

## Place Compact I/O Modules

You can DIN rail or panel mount the controller and I/O modules. The number of local I/O modules that are supported depends on the controller.

Controller	Supports	Location	Considerations
1769-L24ER-QB1B 1769-L24ER-QBFC1B 1769-L27ERM-QBFC1B	4 local modules	Right side of the controller	The additional modules are connected directly to the controller. There are no additional banks of local I/O.
1769-L30ER 1769-L30ERM 1769-L30ER-NSE	8 local modules	1 separate bank	Standard 1769 power supplies power the additional banks and connect to the main rack by using standard 1769 expansion cables.
1769-L33ER 1769-L33ERM	16 local modules	2 separate banks	
1769-L36ERM	30 local modules	3 separate banks	
1769-L23E-QB1B 1769-L23E-QBFC1B 1769-L23-QBFC1B	2 local modules, V17 and earlier	Right side of the packaged controller	The additional modules are connected directly to the packaged controller. There are no additional banks of local I/O.
1769-L23E-QB1B	3 local modules, v18 and later		
1769-L35CR 1769-L35E	30 local modules	3 separate banks	Standard 1769 power supplies power the additional banks and connect to the main rack by using standard 1769 expansion cables.
1769-L32C 1769-L32E 1769-L31	16 local modules	3 separate banks	
1768-L43	16 local modules	3 separate banks	
1768-L45	30 local modules	3 separate banks	As many as eight 1769 local modules can be attached to the 1768 backplane. The remaining modules can be in one or two additional I/O banks. Standard 1769 power supplies power the additional banks and connect to the main rack by using standard 1769 expansion cables.

Each 1769 Compact I/O module has a distance rating. In 1769 systems, the distance rating is the number of modules between the specific module and the 1769 power supply. In a 1768 system, the distance rating is the number of modules between the specific I/O module and the 1768 controller.

## Digital I/O Modules

Choose digital I/O modules when you need these features.

Type	Description
Input	<p>An input module responds to an input signal in this manner:</p> <ul style="list-style-type: none"> <li>• Input filtering limits the effect of voltage transients that contact bounce and/or electrical noise cause. If not filtered, voltage transients could produce false data. All input modules use input filtering.</li> <li>• Optical isolation shields logic circuits from possible damage due to electrical transients.</li> <li>• Logic circuits process the signal.</li> <li>• An input indicator turns on or off, which indicates the status of the corresponding input device.</li> </ul>
Output	<p>An output module controls the output signal in this manner:</p> <ul style="list-style-type: none"> <li>• Logic circuits determine the output status.</li> <li>• An output indicator displays the status of the output signal.</li> <li>• Optical isolation separates module logic and bus circuits from field power.</li> <li>• The output driver turns the corresponding output on or off.</li> </ul>

Most output modules have built-in surge suppression to reduce the effects of high-voltage transients. Use an additional suppression device if an output is being used to control inductive devices, such as relays, motor starters, solenoids, or motors.

Additional suppression is especially important if your inductive device is in series with or parallel to hard contacts, such as push buttons or selector switches. Add a suppression device directly across the coil of an inductive device. The suppression device reduces the effects of voltage transients that are caused by interrupting the current to that device and to prolong the life of the switch contacts.

These digital modules are available.

I/O Type	Cat. No.	Description	Page
AC digital input	1769-IA81, 1769-IA81K	Compact individually isolated 120V AC input module	6
	1769-IA16, 1769-IA16K	Compact 120V AC input module	7
	1769-IM12	Compact 240V AC input module	8
AC digital output	1769-OA8	Compact 100/240V AC solid-state output module	9
	1769-OA16, 1769-OA16K	Compact 120/240V AC solid-state output module	10
DC digital input	1769-I616	Compact TTL input module	11
	1769-IQ16, 1769-IQ16K	Compact 24V DC sink/source input module	12
	1769-IQ16F	Compact 24V DC sink/source, high-speed input module	13
	1769-IQ32, 1769-IQ32K	Compact 24V DC sink/source input module	14
	1769-IQ32T	Compact 24V DC sink/source, terminated input module	15
	1769-IQ6XOW4	Compact combination 24V DC sink/source input and AC/DC relay output module	16
DC digital output	1769-OB8, 1769-OB8K	Compact solid-state 24V DC source, high-current output module	17
	1769-OB16, 1769-OB16K	Compact solid-state 24V DC source output module	18
	1769-OB16P	Compact solid-state 24V DC source, protected output module	19
	1769-OB32, 1769-OB32K	Compact solid-state 24V DC source output module	20
	1769-OB32T	Compact solid-state 24V DC source, terminated output module	21
	1769-OG16	Compact TTL output module	22
	1769-OV16	Compact solid-state 24V DC sink output module	23
	1769-OV32T	Compact solid-state 24V DC sink, terminated output module	24

## 1769-IA8I, 1769-IA8IK

### Compact individually isolated 120V AC input module

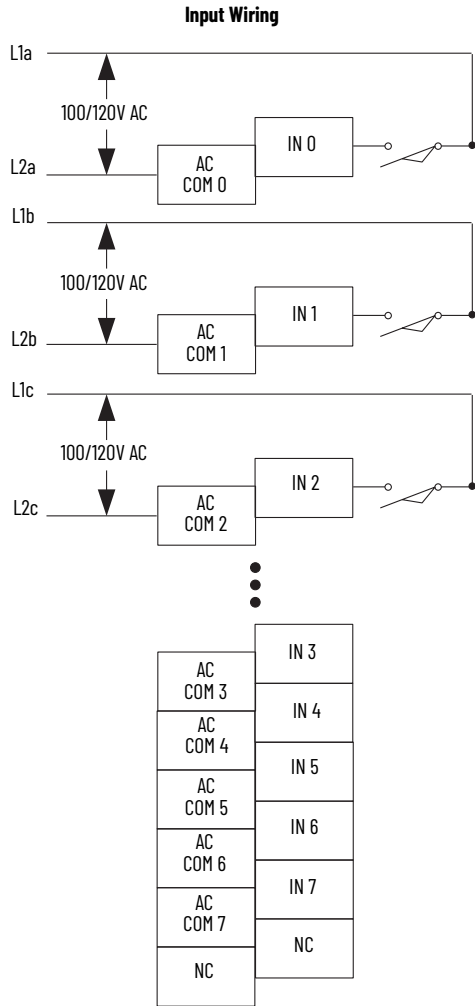

### Technical Specifications - 1769-IA8I, 1769-IA8IK

Attribute	1769-IA8I, 1769-IA8IK
Inputs	8 individually isolated
Voltage category	100/120V AC
Operating voltage range	79...132V AC 47...63 Hz
Input delay, on	20 ms
Input delay, off	20 ms
Current draw @ 5.1V	90 mA
Heat dissipation, max	1.81 W
Off-state voltage, max	20V AC
Off-state current, max	2.5 mA
On-state voltage, min	79V AC
On-state current, min	5 mA @ 74V AC
On-state current, max	12 mA @ 120V AC
Inrush current, max <sup>(1)</sup>	250 mA
Input impedance, max	12 kW @ 50 Hz 10 kW @ 60 Hz
Isolation voltage	Verified by one of these dielectric tests: 1517V AC for 1 s or 2145V DC for 1 s, input point to bus and group to group 132V AC working voltage (IEC Class II reinforced insulation)
Weight, approx	270 g (0.60 lb)
Dimensions (HxWxD), approx	118 x 35 x 87 mm (4.65 x 1.38 x 3.43 in.) Height with mounting tabs 138 mm (5.43 in.)
Slot width	1
Module location	DIN rail or panel mount
Power supply	1769-PA2, 1769-PB2, 1769-PA4, 1769-PB4
Power supply distance rating	8 modules
Terminal screw torque	0.68 N•m (6 lb•in)
Retaining screw torque	0.46 N•m (4.1 lb•in)
Wire size	(22...14 AWG) solid (22...16 AWG) stranded
Wire type	Cu-90 °C (194 °F)
IEC input compatibility	Type 1+
Replacement terminal block	1769-RTBN18 (1 per kit)
Replacement door label	1769-RL1 (2 per kit)
Replacement door	1769-RD (2 per kit)
Vendor ID code	1
Product type code	7
Product code	81
Enclosure type rating	None (open-style)

(1) A current limiting resistor can be used to limit inrush current; however, the operating characteristics of the AC input circuit are affected. If a 6.8 kW (2.5 W minimum) resistor is placed in series with the input, the inrush current is reduced to 35 mA. In this configuration, the minimum on-state voltage increases to 92V AC. Before adding the resistor in a hazardous environment, be sure to consider the operating temperature of the resistor and the temperature limits of the environment. The operating temperature of the resistor must remain below the temperature limit of the environment.

For **Environmental Specifications**, see [page 2](#).

For **Certifications**, see [page 3](#).

## 1769-IA16, 1769-IA16K

## Compact 120V AC input module

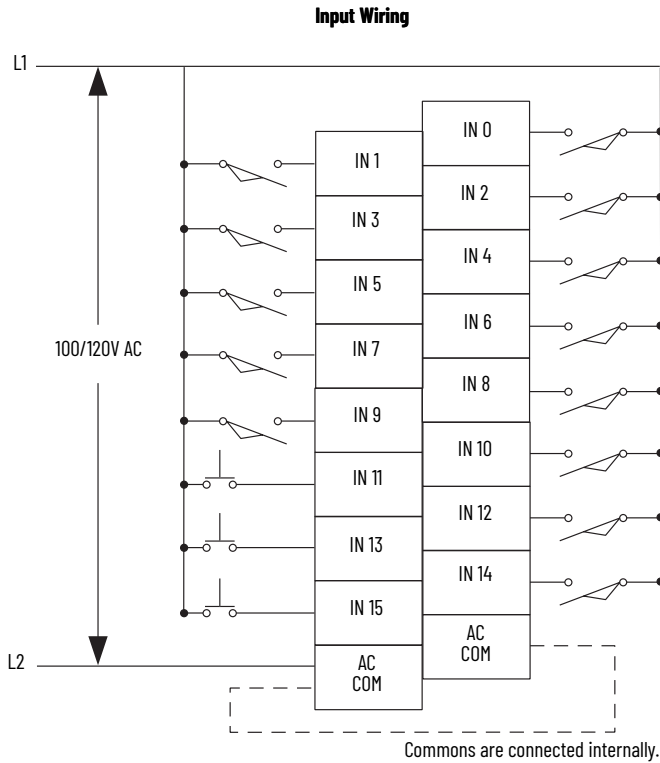

## Technical Specifications - 1769-IA16, 1769-IA16K

Attribute	1769-IA16, 1769-IA16K
Inputs	16 (16 points/group, internally connected commons)
Voltage category	100/120V AC
Operating voltage range	79...132V AC 47...63 Hz
Input delay, on	20 ms
Input delay, off	20 ms
Current draw @ 5.1V	115 mA
Heat dissipation, max	3.30 W
Off-state voltage, max	20V AC
Off-state current, max	2.5 mA
On-state voltage, min	79V AC
On-state current, min	5 mA @ 74V AC
On-state current, max	12 mA @ 120V AC
Inrush current, max <sup>(1)</sup>	250 mA
Input impedance, max	12 kW @ 50 Hz 10 kW @ 60 Hz
Isolation voltage	Verified by one of these dielectric tests: 1517V AC for 1 s or 2145V DC for 1 s, input point to bus 132V AC working voltage (IEC Class II reinforced insulation)
Weight, approx	280 g (0.61 lb)
Dimensions (HxWxD), approx	118 x 35 x 87 mm (4.65 x 1.38 x 3.43 in.) Height with mounting tabs 138 mm (5.43 in.)
Slot width	1
Module location	DIN rail or panel mount
Power supply	1769-PA2, 1769-PB2, 1769-PA4, 1769-PB4
Power supply distance rating	8 modules
Terminal screw torque	0.68 N•m (6 lb•in)
Retaining screw torque	0.46 N•m (4.1 lb•in)
Wire size	(22...14 AWG) solid (22...16 AWG) stranded
Wire type	Cu-90 °C (194 °F)
IEC input compatibility	Type 1+
Replacement terminal block	1769-RTBN18 (1 per kit)
Replacement door label	1769-RL1 (2 per kit)
Replacement door	1769-RD (2 per kit)
Vendor ID code	1
Product type code	7
Product code	82
Enclosure type rating	None (open-style)

(1) A current limiting resistor can be used to limit inrush current; however, the operating characteristics of the AC input circuit are affected. If a 6.8 kW (2.5 W minimum) resistor is placed in series with the input, the inrush current is reduced to 35 mA. In this configuration, the minimum on-state voltage increases to 92V AC. Before adding the resistor in a hazardous environment, be sure to consider the operating temperature of the resistor and the temperature limits of the environment. The operating temperature of the resistor must remain below the temperature limit of the environment.

For **Environmental Specifications**, see [page 2](#).

For **Certifications**, see [page 3](#).

# 1769-IM12

## Compact 240V AC input module

Input Wiring

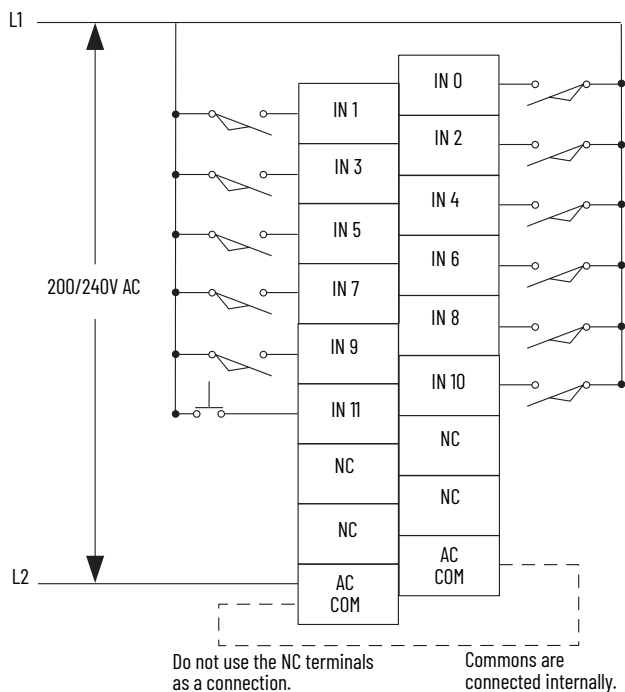

## Technical Specifications - 1769-IM12

Attribute	1769-IM12
Inputs	12 (12 points/group, internally connected commons)
Voltage category	200/240V AC
Operating voltage range	159...265V AC 47...63 Hz
Input delay, on	20 ms
Input delay, off	20 ms
Current draw @ 5.1V	100 mA
Heat dissipation, max	3.65 W
Off-state voltage, max	40V AC
Off-state current, max	2.5 mA
On-state voltage, min	159V AC
On-state current, min	5 mA @ 74V AC
On-state current, max	12 mA @ 120V AC
Inrush current, max <sup>(1)</sup>	250 mA
Input impedance, max	27 kW @ 50 Hz 23 kW @ 60 Hz
Isolation voltage	Verified by one of these dielectric tests: 1836V AC for 1 s or 2596V DC for 1 s, input point to bus 132V AC working voltage (IEC Class II reinforced insulation)
Weight, approx	300 g (0.61 lb)
Dimensions (HxWxD), approx	118 x 35 x 87 mm (4.65 x 1.38 x 3.43 in.) Height with mounting tabs 138 mm (5.43 in.)
Slot width	1
Module location	DIN rail or panel mount
Power supply	1769-PA2, 1769-PB2, 1769-PA4, 1769-PB4
Power supply distance rating	8 modules
Terminal screw torque	0.68 N•m (6 lb•in)
Retaining screw torque	0.46 N•m (4.1 lb•in)
Wire size	(22...14 AWG) solid (22...16 AWG) stranded
Wire type	Cu-90 °C (194 °F)
IEC input compatibility	Type 1+
Replacement terminal block	1769-RTBN18 (1 per kit)
Replacement door label	1769-RL1 (2 per kit)
Replacement door	1769-RD (2 per kit)
Vendor ID code	1
Product type code	7
Product code	83
Enclosure type rating	None (open-style)

(1) A current limiting resistor can be used to limit inrush current; however, the operating characteristics of the AC input circuit are affected. If a 6.8 kW (2.5 W minimum) resistor is placed in series with the input, the inrush current is reduced to 35 mA. In this configuration, the minimum on-state voltage increases to 92V AC. Before adding the resistor in a hazardous environment, be sure to consider the operating temperature of the resistor and the temperature limits of the environment. The operating temperature of the resistor must remain below the temperature limit of the environment.

For **Environmental Specifications**, see [page 2](#).

For **Certifications**, see [page 3](#).

# 1769-OA8

## Compact 100/240V AC solid-state output module

Simplified Output Circuit Diagram

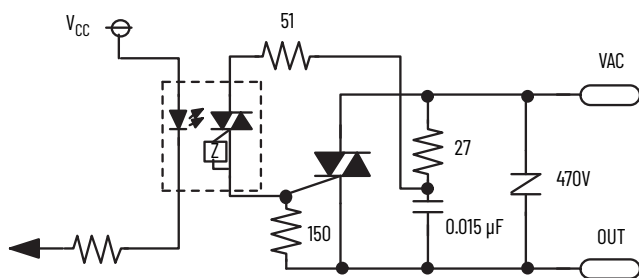

Output Wiring

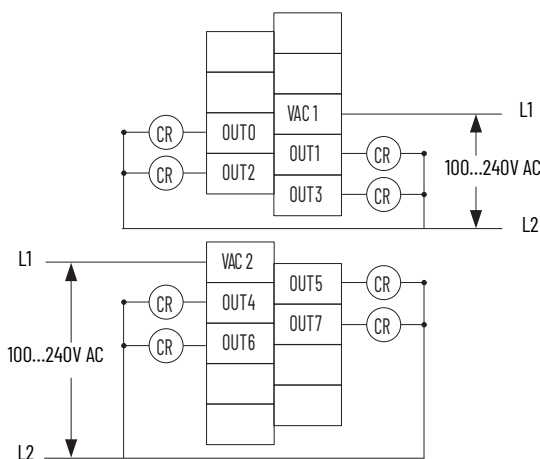

### Technical Specifications - 1769-OA8

Attribute	1769-OA8
Outputs	8 (4 points/group)
Voltage category	100/240V AC
Operating voltage range	85...265V AC 47...63 Hz
Output delay, on <sup>(1)</sup>	1/2 cycle
Output delay, off <sup>(1)</sup>	1/2 cycle
Current draw @ 5.1V	145 mA
Heat dissipation, max	2.12 W
Off-state leakage current, max <sup>(2)</sup>	2.0 mA @ 132V AC 2.5 mA @ 265V AC
On-state current, max	10 mA
On-state voltage drop, max	1.5V peak @ 2 A
Current per point, max	0.25 A @ 60 °C 0.5 A @ 30 °C
Current per module, max	2 A @ 60 °C 4 A @ 30 °C
Surge current <sup>(3)</sup>	10 A for 25 ms, repeatable every 2 s
Isolation voltage	Verified by one of these dielectric tests: 1836V AC for 1 s or 2596V DC for 1 s, group to group 265V AC working voltage (basic insulation) 150V AC working voltage (IEC Class II reinforced insulation)
Weight, approx	280 g (0.61 lb)

### Technical Specifications - 1769-OA8

Attribute	1769-OA8
Dimensions (HxWxD), approx	118 x 35 x 87 mm (4.65 x 1.38 x 3.43 in.) Height with mounting tabs 138 mm (5.43 in.)
Slot width	1
Module location	DIN rail or panel mount
Power supply	1769-PA2, 1769-PB2, 1769-PA4, 1769-PB4
Power supply distance rating	8 modules
Terminal screw torque	0.68 N·m (6 lb·in)
Retaining screw torque	0.46 N·m (4.1 lb·in)
Wire size	(22...14 AWG) solid (22...16 AWG) stranded
Wire type	Cu-90 °C (194 °F)
Replacement terminal block	1769-RTBN10 (1 per kit)
Replacement door label	1769-RL1 (2 per kit)
Replacement door	1769-RD (2 per kit)
Vendor ID code	1
Product type code	7
Product code	84
Enclosure type rating	None (open style)

- (1) Triac outputs turn on and off at AC line zero cross.
- (2) To limit the effects of leakage current through solid-state outputs, a loading resistor can be connected in parallel with your load. For 120V AC operation, use a 15 kW, 2 W resistor. For 240V AC operation, use a 5 kW, 5 W resistor.
- (3) If you connect surge suppressors across your external load, you extend the life of the triac outputs.

### Temperature Derating - 1769-OA8

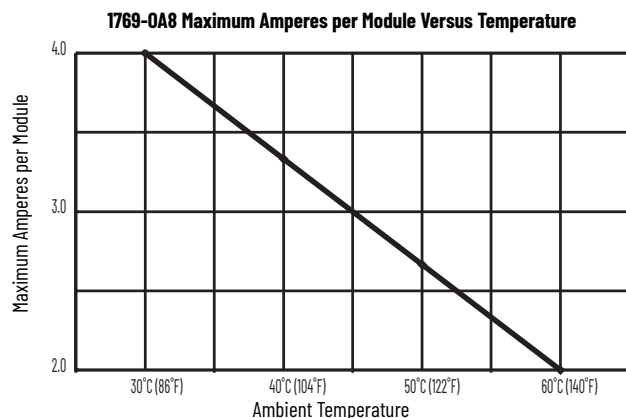
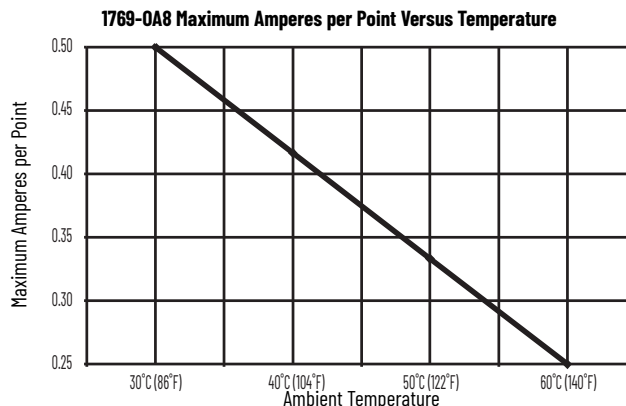

For Environmental Specifications, see [page 2](#).

For Certifications, see [page 3](#).

## 1769-0A16, 1769-0A16K

### Compact 120/240V AC solid-state output module

Simplified Output Circuit Diagram

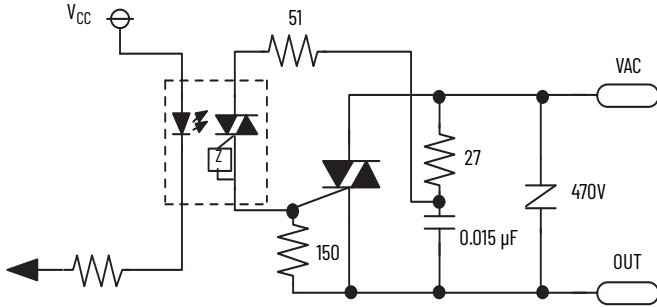

Output Wiring

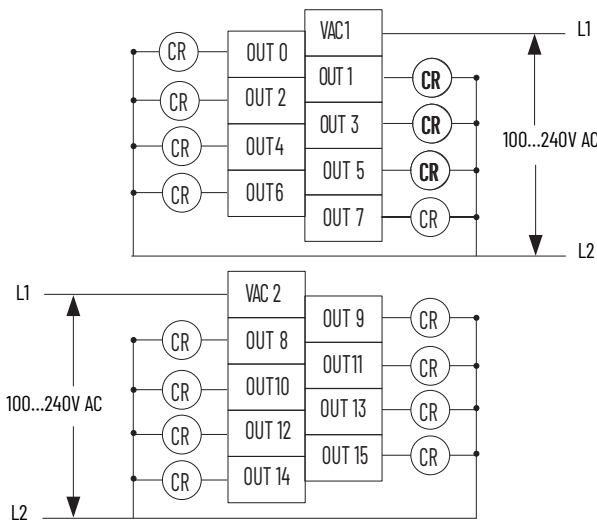

### Technical Specifications - 1769-0A16, 1769-0A16K

Attribute	1769-0A16
Outputs	16 (8 points/group)
Voltage category	100/240V AC
Operating voltage range	85...265V AC 47...63 Hz
Output delay, on <sup>(1)</sup>	1/2 cycle
Output delay, off <sup>(1)</sup>	1/2 cycle
Current draw @ 5.1V	225 mA
Heat dissipation, max	4.9 W
Off-state leakage current, max <sup>(2)</sup>	2.0 mA @ 132V AC 2.5 mA @ 265V AC
On-state current, max	10 mA
On-state voltage drop, max	1.5V peak @ 2 A
Current per point, max	0.25 A @ 60 °C 0.5 A @ 30 °C
Current per module, max	2 A @ 60 °C 4 A @ 30 °C
Surge current <sup>(3)</sup>	5 A for 25 ms, repeatable every 2 s
Isolation voltage	Verified by one of these dielectric tests: 1836V AC for 1 s or 2596V DC for 1 s, output point to bus <ul style="list-style-type: none"> <li>• 265V AC working voltage (IEC Class II reinforced, basic insulation)</li> <li>• 150V AC working voltage (IEC Class II reinforced, basic insulation)</li> </ul>

### Technical Specifications - 1769-0A16, 1769-0A16K

Attribute	1769-0A16
Weight, approx	280 g (0.61 lb)
Dimensions (HxWxD), approx	118 x 35 x 87 mm (4.65 x 1.38 x 3.43 in.) Height with mounting tabs 138 mm (5.43 in.)
Slot width	1.5
Module location	DIN rail or panel mount
Power supply	1769-PA2, 1769-PB2, 1769-PA4, 1769-PB4
Power supply distance rating	8 modules
Terminal screw torque	0.68 N•m (6 lb•in)
Retaining screw torque	0.46 N•m (4.1 lb•in)
Wire size	(22...14 AWG) solid (22...16 AWG) stranded
Wire type	Cu-90 °C (194 °F)
Replacement terminal block	1769-RTBN18 (1 per kit)
Replacement door	Not available
Vendor ID code	1
Product type code	7
Product code	93
Enclosure type rating	None (open style)

- (1) Triac outputs turn on and off at AC line zero cross.
- (2) To limit the effects of leakage current through solid-state outputs, a loading resistor can be connected in parallel with your load. For 120V AC operation, use a 15 kW, 2 W resistor. For 240V AC operation, use a 5 kW, 5 W resistor.
- (3) If you connect surge suppressors across your external load, you extend the life of the triac outputs.

### Temperature Derating - - 1769-0A16, 1769-0A16K

1769-0A16 Maximum Amperes per Point Versus Temperature

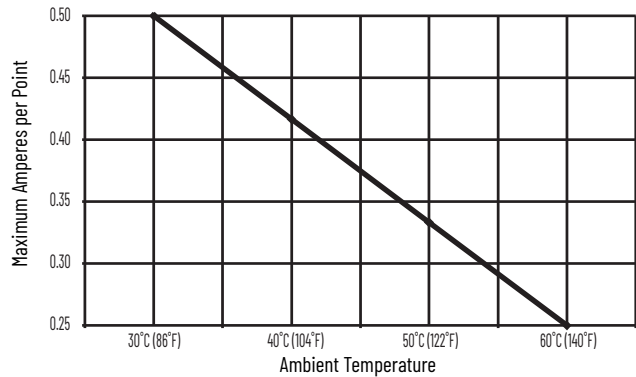

1769-0A16 Maximum Amperes per Module Versus Temperature

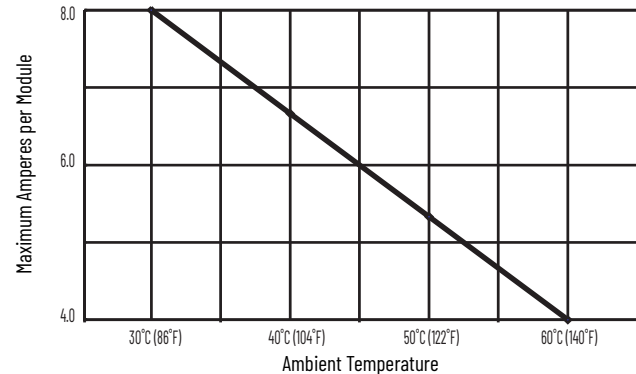

For Environmental Specifications, see [page 2](#).

For Certifications, see [page 3](#).

## 1769-IG16

### Compact TTL input module

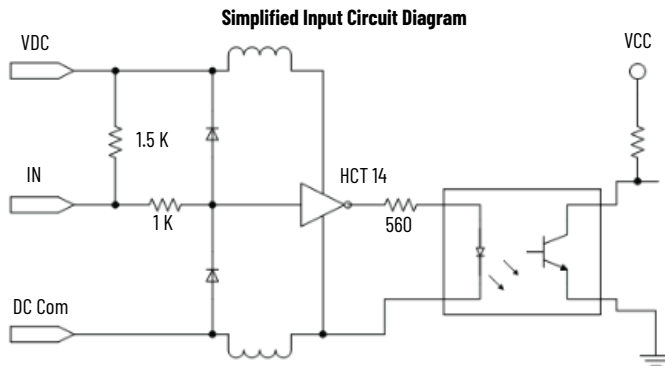

- Use Belden 8761, or equivalent, shielded wire.
- Do not connect more than two wires to any single terminal.
- Do not exceed 10 m (30 ft) for the DC power cable and I/O cables.
- The capacitors that are shown in the diagram must be 0.01  $\mu$ F and rated for 2000V min.
- User power supply must be rated Class 2 with a 5V DC range of 4.5...5.5V DC.

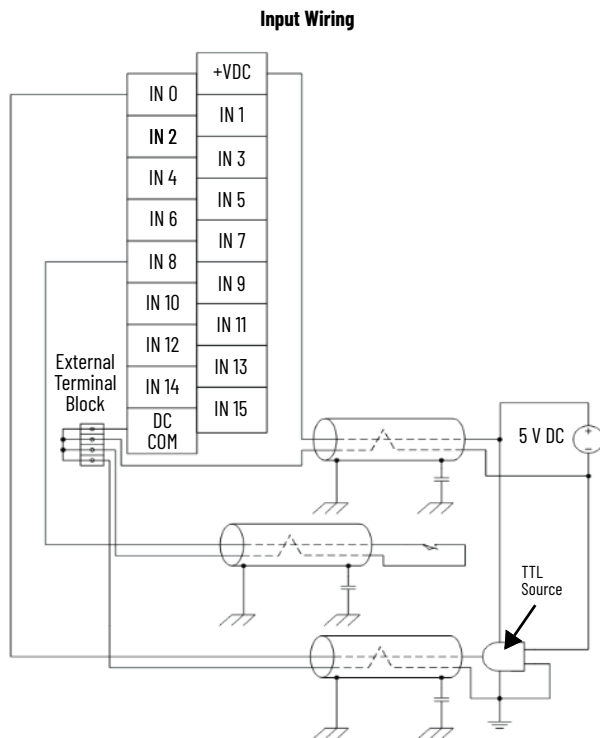

### Low to True Format - 1769-IG16

- -0.2...0.8V = Input on-state is guaranteed
- 0.8...2.0V = Input state is not guaranteed
- 2.0...5.5V = Input off-state is guaranteed

### Technical Specifications - 1769-IG16

Attribute	1769-IG16
Inputs	16
Voltage category	5V DC TTL source (Low=True) <sup>(1)</sup>
Operating voltage range	4.5...5.5V DC 50 mV peak-to-peak ripple max
Input delay, on	20 ms
Digital filter, off to on	0 s, 100 ms, 500 ms, 1 ms, 2 ms, 4 ms, 8 ms
Digital filter, on to off	0 s, 100 ms, 500 ms, 1 ms, 2 ms, 4 ms, 8 ms
Current draw @ 5.1V	120 mA
Heat dissipation, max	1.6 W
Off-state voltage, typical	2.0...5.5V DC
Off-state current, max	4.1 mA
On-state voltage, typical	-0.2...0.8V DC
On-state current, nom	3.7 mA @ 5V DC
Isolation voltage	Verified by one of these dielectric tests: 1200V AC for 2 s or 1697V DC for 2 s, input point to bus 75V DC working voltage (IEC Class II reinforced insulation)
Weight, approx	250 g (0.55 lb)
Dimensions (HxWxD), approx	118 x 35 x 87 mm (4.65 x 1.38 x 3.43 in.) Height with mounting tabs 138 mm (5.43 in.)
Slot width	1
Module location	DIN rail or panel mount
Power supply	1769-PA2, 1769-PB2, 1769-PA4, 1769-PB4
Power supply distance rating	8 modules
Terminal screw torque	0.68 N•m (6 lb•in)
Retaining screw torque	0.46 N•m (4.1 lb•in)
Wire size	(22...14 AWG) solid (22...16 AWG) stranded
Wire type	Cu-90 °C (194 °F)
IEC input compatibility	No
Vendor ID code	1
Product type code	7
Product code	77
Input words	1
Output words	0
Configuration words	4
Enclosure type rating	None (open-style)

(1) TTL inputs are inverted (-0.2...0.8 = low voltage = True = On.) Use a NOT instruction in your program to convert to traditional True = High logic.

For **Environmental Specifications**, see [page 2](#).

For **Certifications**, see [page 3](#).

## 1769-IQ16, 1769-IQ16K

### Compact 24V DC sink/source input module

Simplified Input Circuit Diagram

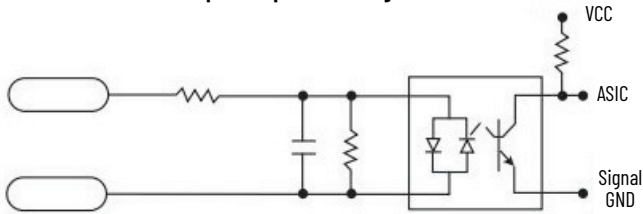

Input Wiring

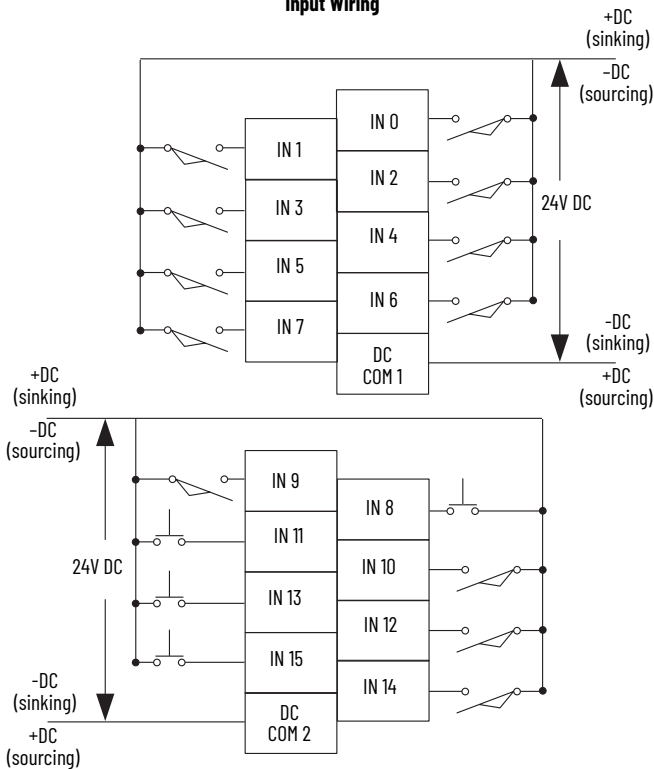

### Technical Specifications - 1769-IQ16, 1769-IQ16K

Attribute	1769-IQ16, 1769-IQ16K
Inputs	16 (8 points/group)
Voltage category	24V DC sink/source
Operating voltage range	10...30V DC @ 30 °C (86 °F) 10...26.4V DC @ 60 °C (140 °F)
Input delay, on	8 ms
Input delay, off	8 ms
Current draw @ 5.1V	115 mA
Heat dissipation, max	3.55 W
Off-state voltage, max	5V DC
Off-state current, max	1.5 mA
On-state voltage, min	10V DC
On-state current, min	2 mA
Inrush current, max	250 mA
Input impedance, nom	3 kW
Isolation voltage	Verified by one of these dielectric tests: 1200V AC for 1 s or 1697V DC for 1 s, input point to bus and group to group 75V DC working voltage (IEC Class II reinforced insulation)
Weight, approx	270 g (0.60 lb)
Dimensions (HxWxD), approx	118 x 35 x 87 mm (4.65 x 1.38 x 3.43 in.) Height with mounting tabs 138 mm (5.43 in.)
Slot width	1
Module location	DIN rail or panel mount
Power supply	1769-PA2, 1769-PB2, 1769-PA4, 1769-PB4
Power supply distance rating	8 modules
Terminal screw torque	0.68 N•m (6 lb•in)
Retaining screw torque	0.46 N•m (4.1 lb•in)
Wire size	(22...14 AWG) solid (22...16 AWG) stranded
Wire type	Cu-90 °C (194 °F)
IEC input compatibility	Type 1+
Replacement terminal block	1769-RTBN18 (1 per kit)
Replacement door label	1769-RL1 (2 per kit)
Replacement door	1769-RD (2 per kit)
Vendor ID code	1
Product type code	7
Product code	67
Enclosure type rating	None (open-style)

For **Environmental Specifications**, see [page 2](#).

For **Certifications**, see [page 3](#).

## 1769-IQ16F

## Compact 24V DC sink/source, high-speed input module

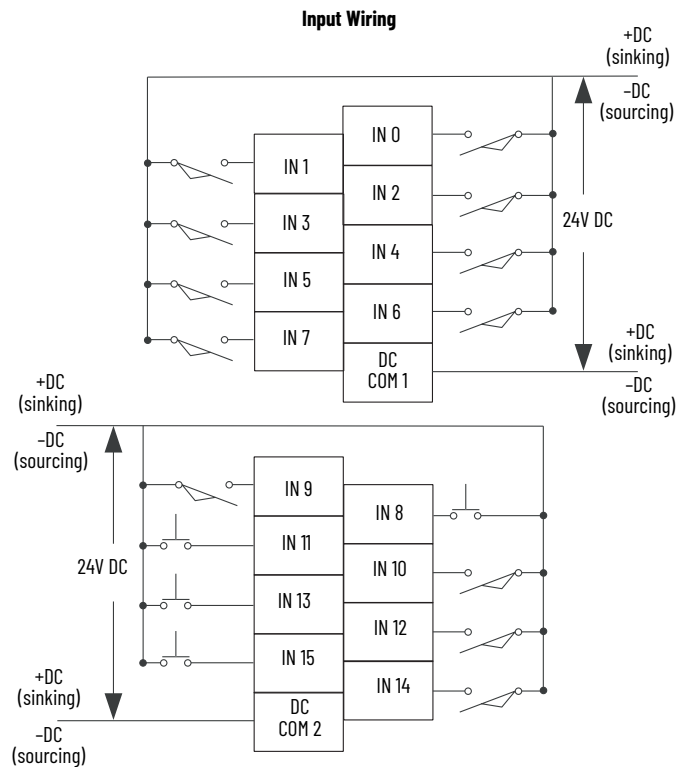

## Technical Specifications - 1769-IQ16F

Attribute	1769-IQ16F
Inputs	16 (8 points/group)
Voltage category	24V DC sink/source
Operating voltage range	10...30V DC @ 30 °C (86 °F) 10...26.4V DC @ 60 °C (140 °F)
Digital filter, off to on	0 s, 100 ms, 500 ms, 1 ms, 2 ms
Digital filter, on to off	0 s, 100 ms, 500 ms, 1 ms, 2 ms
Input delay, off to on	100 ms, typical 300 ms, max
Input delay, on to off	250 ms, typical 1 ms, max
Current draw @ 5.1V	110 mA
Heat dissipation, max	3.55 W
Off-state voltage, max	5V DC
Off-state current, max	1.5 mA
On-state voltage, min	10V DC
On-state current, min	2 mA
Inrush current, max	250 mA
Input impedance, nom	3 kW
Isolation voltage	Verified by one of these dielectric tests: 1200V AC for 1 s or 1697V DC for 1 s, input point to bus and group to group 75V DC working voltage (IEC Class II reinforced insulation)
Weight, approx	270 g (0.60 lb)
Dimensions (HxWxD), approx	118 x 35 x 87 mm (4.65 x 1.38 x 3.43 in.) Height with mounting tabs 138 mm (5.43 in.)
Slot width	1
Module location	DIN rail or panel mount
Power supply	1769-PA2, 1769-PB2, 1769-PA4, 1769-PB4
Power supply distance rating	8 modules
Terminal screw torque	0.68 N•m (6 lb•in)
Retaining screw torque	0.46 N•m (4.1 lb•in)
Wire size	(22...14 AWG) solid (22...16 AWG) stranded
Wire type	Cu-90 °C (194 °F)
IEC input compatibility	Type 1+
Replacement terminal block	1769-RTBN18 (1 per kit)
Replacement door label	1769-RL1 (2 per kit)
Replacement door	1769-RD (2 per kit)
Vendor ID code	1
Product type code	7
Product code	69
Enclosure type rating	None (open-style)

For **Environmental Specifications**, see [page 2](#).

For **Certifications**, see [page 3](#).

## 1769-IQ32, 1769-IQ32K

### Compact 24V DC sink/source input module

Input wiring

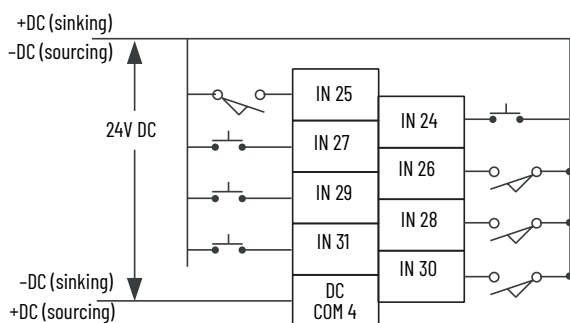
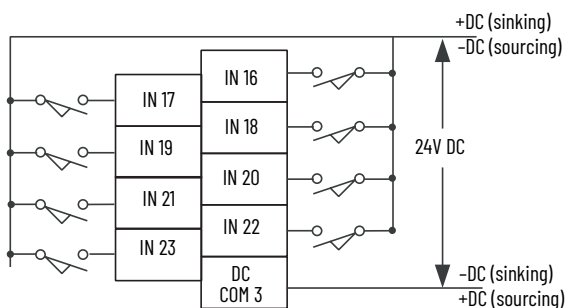
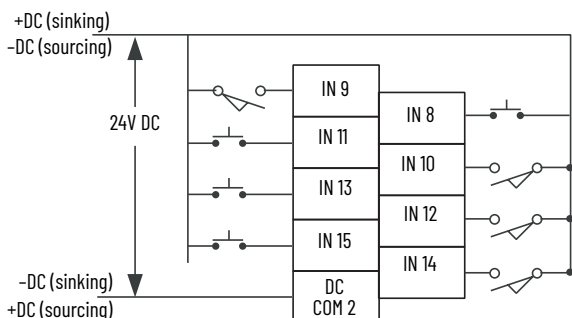
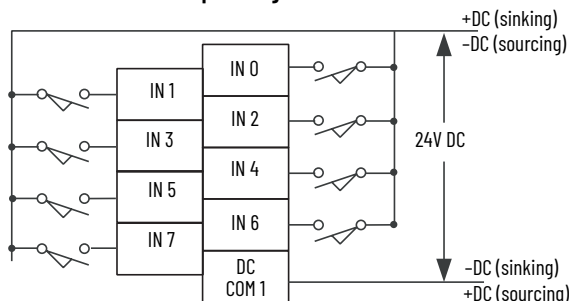

### Technical Specifications - 1769-IQ32, 1769-IQ32K

Attribute	1769-IQ32, 1769-IQ32K
Inputs	32 (8 points/group)
Voltage category	24V DC sink/source
Operating voltage range	10...30V DC @ 30 °C (86 °F) 10...26.4V DC @ 60 °C (140 °F)
Input delay, on	8 ms
Input delay, off	8 ms
Current draw @ 5.1V	170 mA
Heat dissipation, max	4.6 W
Off-state voltage, max	5V DC
Off-state current, max	1.5 mA
On-state voltage, min	10V DC
On-state current, min	2 mA
Inrush current, max	250 mA
Input impedance, nominal	5.2 kW @ 24V DC 6.1 kW @ 30V DC
Isolation voltage	Verified by one of these dielectric tests: 1200V AC for 1 s or 1697V DC for 1 s, input point to bus and group to group 75V DC working voltage (IEC Class II reinforced insulation)
Weight, approx	440 g (0.97 lb)
Dimensions (HxWxD), approx	118 x 52.5 x 87 mm (4.65 x 2.07 x 3.43 in.) Height with mounting tabs 138 mm (5.43 in.)
Slot width	1.5
Module location	DIN rail or panel mount
Power supply	1769-PA2, 1769-PB2, 1769-PA4, 1769-PB4
Power supply distance rating	8 modules
Terminal screw torque	0.68 N•m (6 lb•in)
Retaining screw torque	0.46 N•m (4.1 lb•in)
Wire size	(22...14 AWG) solid (22...16 AWG) stranded
Wire type	Cu-90 °C (194 °F)
IEC input compatibility	Type 1+
Replacement terminal block	1769-RTBN18 (1 per kit)
Replacement door	Not available
Vendor ID code	1
Product type code	7
Product code	68
Enclosure type rating	None (open-style)

For Environmental Specifications, see [page 2](#).

For Certifications, see [page 3](#).

## 1769-IQ32T

## Compact 24V DC sink/source, terminated input module

Input Wiring

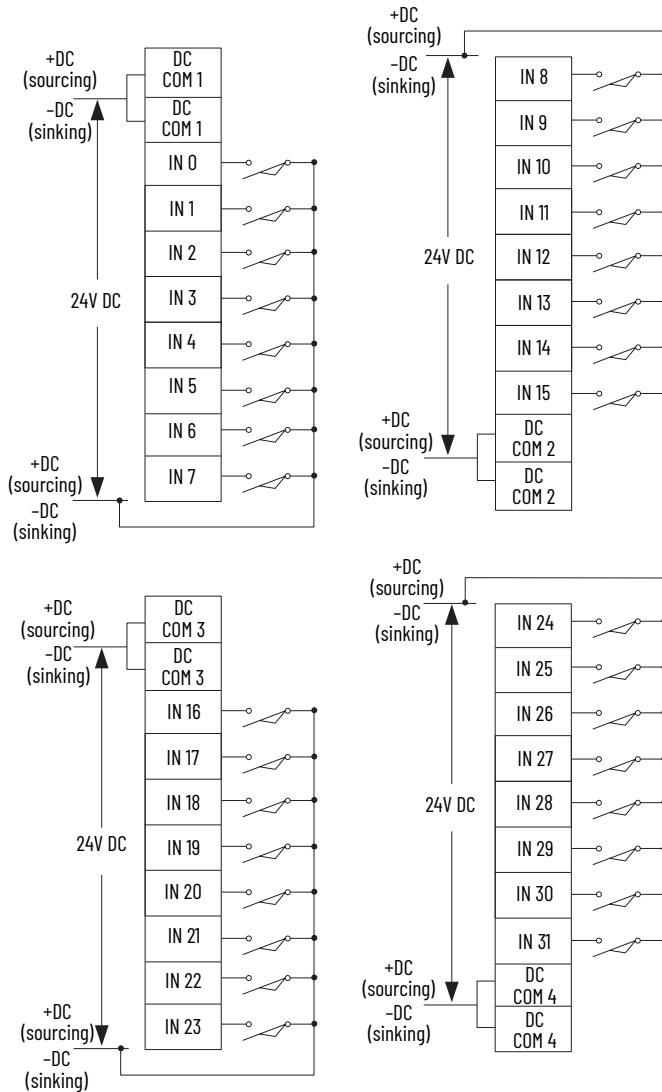

## Technical Specifications - 1769-IQ32T

Attribute	1769-IQ32T
Inputs	32 terminated (8 points/group)
Voltage category	24V DC sink/source
Operating voltage range	20.4...26.4V DC @ 60 °C (140 °F)
Digital filter, off to on	0 s, 100 ms, 500 ms, 1 ms, 2 ms, 4 ms, 8 ms
Digital filter, on to off	0 s, 100 ms, 500 ms, 1 ms, 2 ms, 4 ms, 8 ms
Input delay, off to on	0.1 ms, typical 0.42 ms, max
Input delay, on to off	0.25 ms, typical 1.0 ms, max
Current draw @ 5.1V	170 mA
Heat dissipation, max	4.77 W
Off-state voltage, max	11V DC
Off-state current, max	1.7 mA
On-state voltage, min	19V DC
On-state current, min	2 mA
Inrush current, max	5 mA
Input impedance, nom	5.6 kW
Isolation voltage	Verified by one of these dielectric tests: 1200V AC for 1 s or 1697V DC for 1 s, input point to bus and group to group 75V DC working voltage (IEC Class II reinforced insulation)
Weight, approx	280 g (0.61 lb)
Dimensions (HxWxD), approx	118 x 35 x 87 mm (4.65 x 1.38 x 3.43 in.) Height with mounting tabs 138 mm (5.43 in.)
Slot width	1
Module location	DIN rail or panel mount
Power supply	1769-PA2, 1769-PB2, 1769-PA4, 1769-PB4
Power supply distance rating	8 modules
Terminal screw torque	0.68 N•m (6 lb•in)
Retaining screw torque	0.46 N•m (4.1 lb•in)
Wire size	(22...14 AWG) solid (22...16 AWG) stranded
Wire type	Cu-90 °C (194 °F)
IEC input compatibility	Type 1+
Replacement connector	1746-N3 (1 connector, 40 terminals)
Vendor ID code	1
Product type code	7
Product code	76
Enclosure type rating	None (open-style)

For **Environmental Specifications**, see [page 2](#).

For **Certifications**, see [page 3](#).

# 1769-IQ6XOW4

Compact combination 24V DC sink/source input and AC/DC relay output module

Simplified Input Circuit Diagram

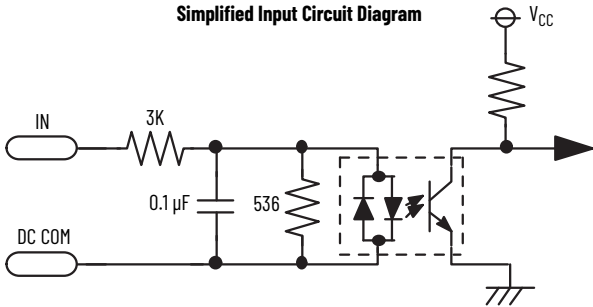

Simplified Output Circuit Diagram

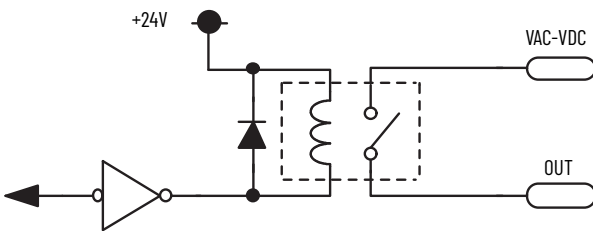

Input and Output Wiring

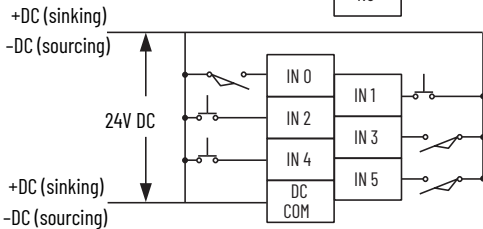
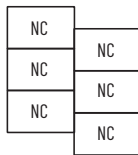
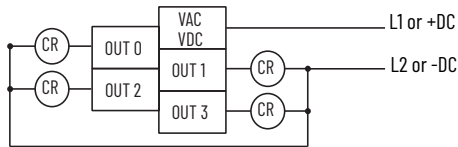

## Technical Specifications - 1769-IQ6XOW4

Attribute	1769-IQ6XOW4
Current draw @ 5.1V	105 mA
Current draw @ 24V	50 mA
Heat dissipation, max	2.75 W
Off-state voltage, max	11V DC
Isolation voltage	Verified by one of these dielectric tests: 1200V AC for 1 s or 1697V DC for 1 s, input group to bus, output group to bus, and input group to output group 75V DC working voltage (IEC Class II reinforced insulation)
Weight, approx	280 g (0.61 lb)
Dimensions (HxWxD), approx	118 x 35 x 87 mm (4.65 x 1.38 x 3.43 in.) Height with mounting tabs 138 mm (5.43 in.)
Slot width	1
Module location	DIN rail or panel mount
Power supply	1769-PA2, 1769-PB2, 1769-PA4, 1769-PB4

## Technical Specifications - 1769-IQ6XOW4

Attribute	1769-IQ6XOW4
Power supply distance rating	8 modules
Terminal screw torque	0.68 N·m (6 lb·in)
Retaining screw torque	0.46 N·m (4.1 lb·in)
Wire size	(22...14 AWG) solid, (22...16 AWG) stranded
Wire type	Cu-90 °C (194 °F)
IEC input compatibility	Type 1+
Replacement terminal block	1769-RTBN18 (1 per kit)
Replacement door label	1769-RL1 (2 per kit)
Replacement door	1769-RD (2 per kit)
Vendor ID code	1
Product type code	7
Product code	66
Enclosure type rating	None (open-style)

## Input Specifications - 1769-IQ6XOW4

Attribute	1769-IQ6XOW4
Inputs	6
Voltage category	24V DC sink/source
Operating voltage range	10...30V DC @ 30 °C (86 °F), 10...26.4V DC @ 60 °C (140 °F)
Delay, on	8 ms
Delay, off	8 ms
Off-state voltage, max	5V DC
Off-state current, max	1.5 mA
On-state voltage, min	10V DC
On-state current, min	2.0 mA
Inrush current, max	250 mA
Input impedance, nom	3 kW
IEC input compatibility	Type 3

## Output Specifications - 1769-IQ6XOW4

Attribute	1769-IQ6XOW4
Outputs	4
Voltage category	AC/DC normally open relay contacts
Operating voltage range	5...265V AC, 5...125V DC
Delay, on	10 ms
Delay, off	10 ms
Off-state leakage, max	0 mA
On-state current, min	10 mA @ 5V DC
Current per point, max	2.5 A
Current per module, max	8 A

## Relay Contact Ratings - 1769-IQ6XOW4

Volts, Max	Continuous Amps per Point, Max	Amperes <sup>(1)</sup>		Voltamperes		NEMA ICS 2-125
		Make	Break	Make	Break	
240V AC	2.5 A	7.5 A	0.75 A	1800VA	180VA	C300
120V AC		15 A	1.5 A			
125V DC	1.0 A	0.22 A <sup>(2)</sup>		28VA		R150
24V DC	2.0 A	1.2 A <sup>(2)</sup>		28VA		—

- If you connect surge suppressors across your external inductive load, you extend the life of the relay contacts.
- For DC voltage applications, you can determine the make/break ampere rating for relay contacts by dividing 28VA by the applied DC voltage. For example, 28 VA/48V DC = 0.58 A. For DC voltage applications less than 48V, the make/break ratings for relay contacts cannot exceed 2 A.

For Environmental Specifications, see [page 2](#).

For Certifications, see [page 3](#).

# 1769-0B8, 1769-0B8K

## Compact solid-state 24V DC source, high-current output module

Simplified Output Circuit Diagram

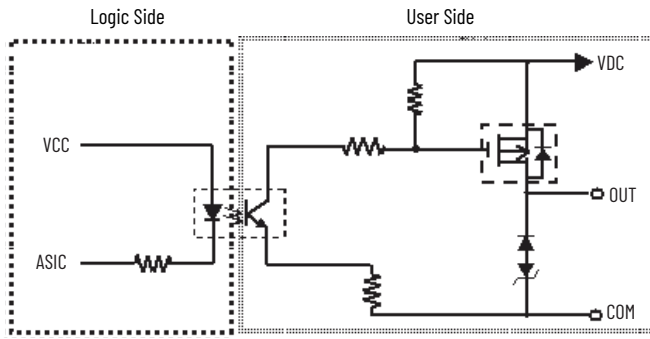

Output Wiring

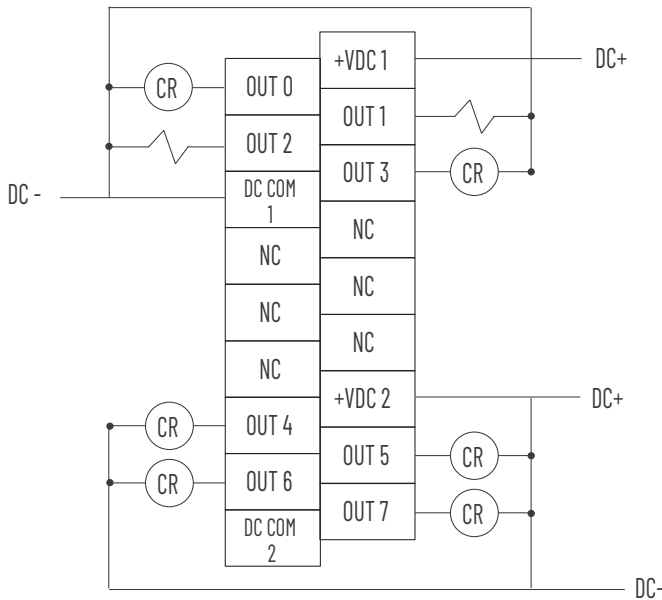

## Technical Specifications - 1769-0B8, 1769-0B8K

Attribute	1769-0B8, 1769-0B8K
Outputs	8 (4 points/group)
Voltage category	24V DC source
Operating voltage range	20.4...26.4V DC
Output delay, on	0.1 ms
Output delay, off	1.0 ms @ 60 °C max load 2 A, min V in 20.4V 1.5 ms @ 60 °C max load 1 mA, min V in 20.4V
Current draw @ 5.1V	145 mA
Heat dissipation, max	2.20 W
Off-state leakage current, max <sup>(1)</sup>	1.0 mA @ 26.4V DC
On-state current, min	1.0 mA
On-state voltage drop, max	1.0V DC @ 2 A
Current per point, max	2.0 A @ 60 °C (140 °F)
Current per module, max	8.0 A @ 60 °C (140 °F)
Surge current <sup>(2)</sup>	4 A for 10 ms, repeatable every 2 s
Isolation voltage	Verified by one of these dielectric tests: 1200V AC for 1 s or 1697V DC for 1 s, output point to bus, and group to group 75V DC working voltage (IEC Class II reinforced insulation)
Weight, approx	280 g (0.61 lb)
Dimensions (HxWxD), approx	118 x 35 x 87 mm (4.65 x 1.38 x 3.43 in.) Height with mounting tabs 138 mm (5.43 in.)
Slot width	1
Module location	DIN rail or panel mount
Power supply	1769-PA2, 1769-PB2, 1769-PA4, 1769-PB4
Power supply distance rating	8 modules
Terminal screw torque	0.68 N•m (6 lb•in)
Retaining screw torque	0.46 N•m (4.1 lb•in)
Wire size	(22...14 AWG) solid (22...16 AWG) stranded
Wire type	Cu-90 °C (194 °F)
Replacement terminal block	1769-RTBN18 (1 per kit)
Replacement door label	1769-RL1 (2 per kit)
Replacement door	1769-RD (2 per kit)
Vendor ID code	1
Product type code	7
Product code	70
Enclosure type rating	None (open style)

(1) To limit the effects of leakage current through solid-state outputs, a loading resistor can be connected in parallel with your load. Use a 5.6 kW, 1/2 W resistor for transistor outputs, 24V DC operation.

(2) Use a 1N4004 diode reverse-wired across the load for transistor outputs switching 24V DC inductive loads.

For **Environmental Specifications**, see [page 2](#).

For **Certifications**, see [page 3](#).

## 1769-OB16, 1769-OB16K

### Compact solid-state 24V DC source output module

Simplified Output Circuit Diagram

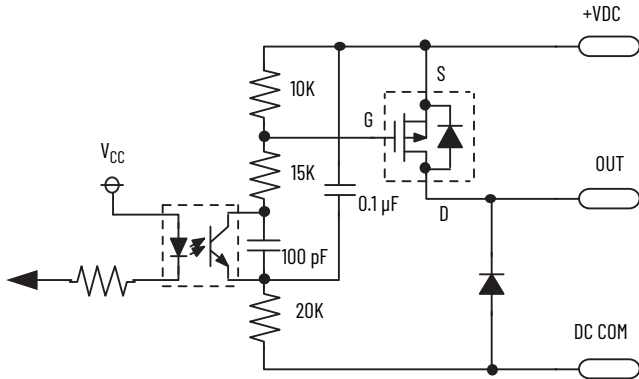

Output Wiring

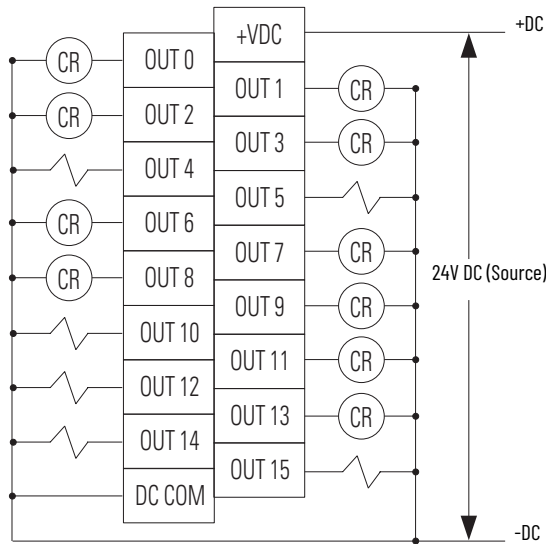

### Technical Specifications - 1769-OB16, 1769-OB16K

Attribute	1769-OB16, 1769-OB16K
Outputs	16 (16 points/group)
Voltage category	24V DC source
Operating voltage range	20.4...26.4V DC
Output delay, on	0.1 ms
Output delay, off	1.0 ms
Current draw @ 5.1V	200 mA
Heat dissipation, max	2.11 W
Off-state leakage current, max <sup>(1)</sup>	1.0 mA @ 26.4V DC
On-state current, min	1.0 mA
On-state voltage drop, max	1.0V DC @ 1A
Current per point, max	0.5 A @ 60 °C (140 °F) 1.0 A @ 30 °C (86 °F)
Current per module, max	4.0 A @ 60 °C (140 °F) 8.0 A @ 30 °C (86 °F)
Surge current <sup>(2)</sup>	2.0 A for 10 ms, repeatable every 2 s
Isolation voltage	Verified by one of these dielectric tests: 1200V AC for 1 s or 1697V DC for 1 s, output point to bus 75V DC working voltage (IEC Class II reinforced insulation)

### Technical Specifications - 1769-OB16, 1769-OB16K

Attribute	1769-OB16, 1769-OB16K
Weight, approx	280 g (0.61 lb)
Dimensions (HxWxD), approx	118 x 35 x 87 mm (4.65 x 1.38 x 3.43 in.) Height with mounting tabs 138 mm (5.43 in.)
Slot width	1
Module location	DIN rail or panel mount
Power supply	1769-PA2, 1769-PB2, 1769-PA4, 1769-PB4
Power supply distance rating	8 modules
Terminal screw torque	0.68 N·m (6 lb·in)
Retaining screw torque	0.46 N·m (4.1 lb·in)
Wire size	(22...14 AWG) solid (22...16 AWG) stranded
Wire type	Cu-90 °C (194 °F)
Replacement terminal block	1769-RTBN18 (1 per kit)
Replacement door label	1769-RL1 (2 per kit)
Replacement door	1769-RD (2 per kit)
Vendor ID code	1
Product type code	7
Product code	71
Enclosure type rating	None (open style)

- (1) To limit the effects of leakage current through solid-state outputs, a loading resistor can be connected in parallel with your load. Use a 5.6 kW, 1/2 W resistor for transistor outputs, 24V DC operation.
- (2) Use a 1N4004 diode reverse-wired across the load for transistor outputs switching 24V DC inductive loads.

### Temperature Derating - 1769-OB16, 1769-OB16K

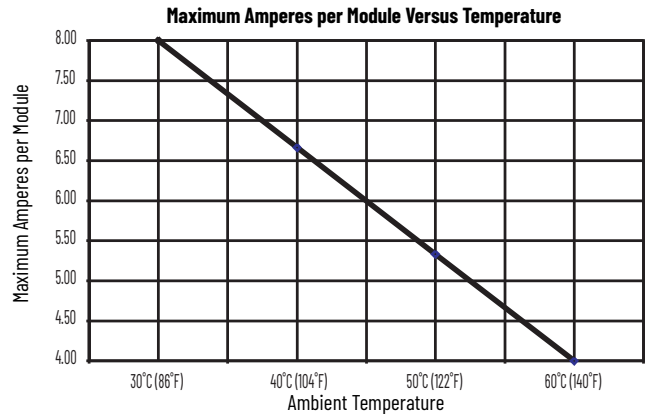
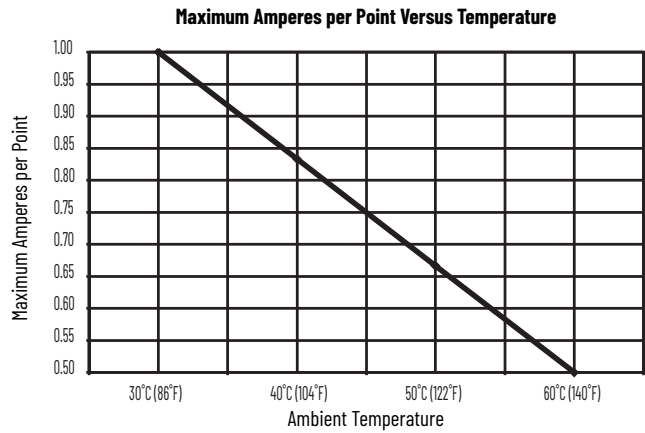

For Environmental Specifications, see [page 2](#).

For Certifications, see [page 3](#).

# 1769-OB16P

## Compact solid-state 24V DC source, protected output module

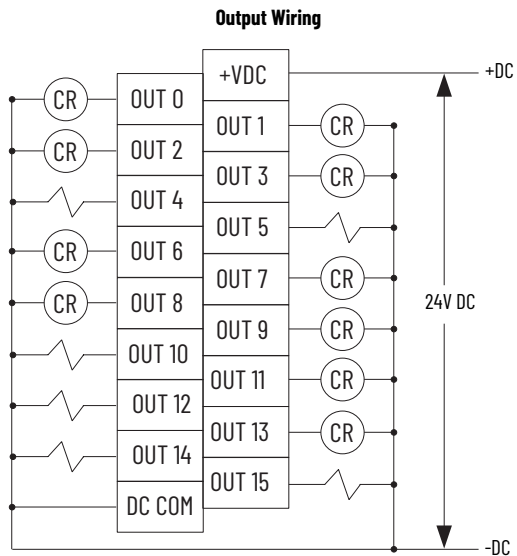
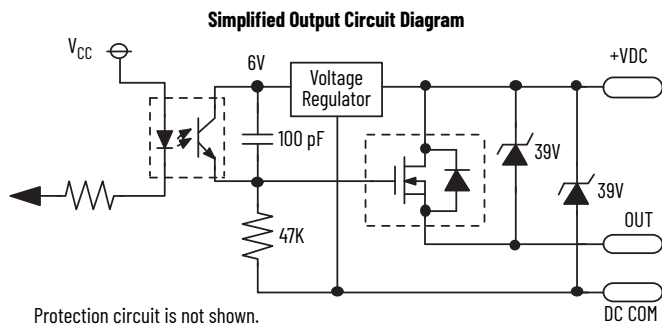

## Technical Specifications - 1769-OB16P

Attribute	1769-OB16P
Outputs	16 (16 points/group)
Voltage category	24V DC source
Operating voltage range	20.4...26.4V DC
Output delay, on	1.0 ms
Output delay, off	2.0 ms
Current draw @ 5.1V	160 mA
Heat dissipation, max	2.69 W
Off-state leakage current, max <sup>(1)</sup>	1.0 mA @ 26.4V DC
On-state current, min	1.0 mA
On-state voltage drop, max	0.5V DC
Current per point, max	0.5 A @ 60 °C (140 °F) 1.0 A @ 30 °C (86 °F)
Current per module, max	4.0 A @ 60 °C (140 °F) 8.0 A @ 30 °C (86 °F)
Surge current <sup>(2)</sup>	2.0 A for 10 ms, repeatable every 1 s
Isolation voltage	Verified by one of these dielectric tests: 1200V AC for 1 s or 1697V DC for 1 s, output point to bus 75V DC working voltage (IEC Class II reinforced insulation)
Weight, approx	255 g (0.56 lb)
Dimensions (HxWxD), approx	118 x 35 x 87 mm (4.65 x 1.38 x 3.43 in.) Height with mounting tabs 138 mm (5.43 in.)
Slot width	1

## Technical Specifications - 1769-OB16P

Attribute	1769-OB16P
Module location	DIN rail or panel mount
Power supply	1769-PA2, 1769-PB2, 1769-PA4, 1769-PB4
Power supply distance rating	8 modules
Terminal screw torque	0.68 N•m (6 lb•in)
Retaining screw torque	0.46 N•m (4.1 lb•in)
Wire size	(22...14 AWG) solid (22...16 AWG) stranded
Wire type	Cu-90 °C (194 °F)
Replacement terminal block	1769-RTBN18 (1 per kit)
Replacement door label	1769-RL1 (2 per kit)
Replacement door	1769-RD (2 per kit)
Vendor ID code	1
Product type code	7
Product code	91
Enclosure type rating	None (open style)

- To limit the effects of leakage current through solid-state outputs, a loading resistor can be connected in parallel with your load. Use a 5.6 kW, 1/2 W resistor for transistor outputs, 24V DC operation.
- Use a 1N4004 diode reverse-wired across the load for transistor outputs switching 24V DC inductive loads.

## Temperature Derating - 1769-OB16P

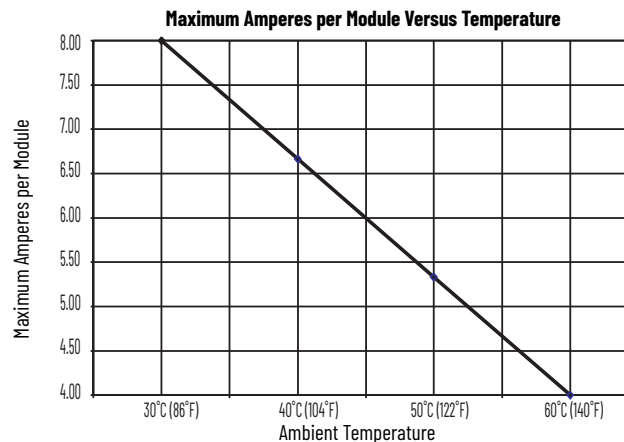
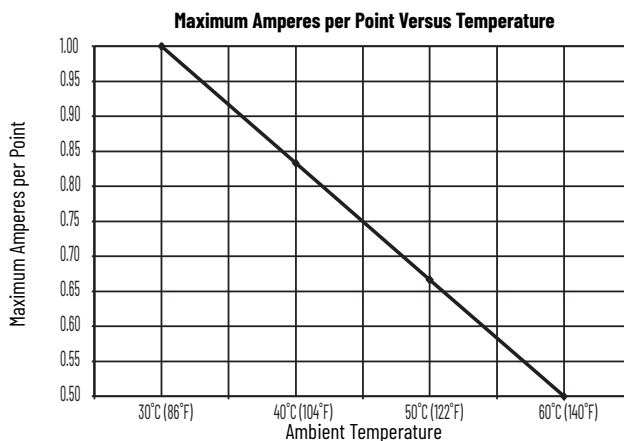

For Environmental Specifications, see [page 2](#).

For Certifications, see [page 3](#).

## 1769-OB32, 1769-OB32K

### Compact solid-state 24V DC source output module

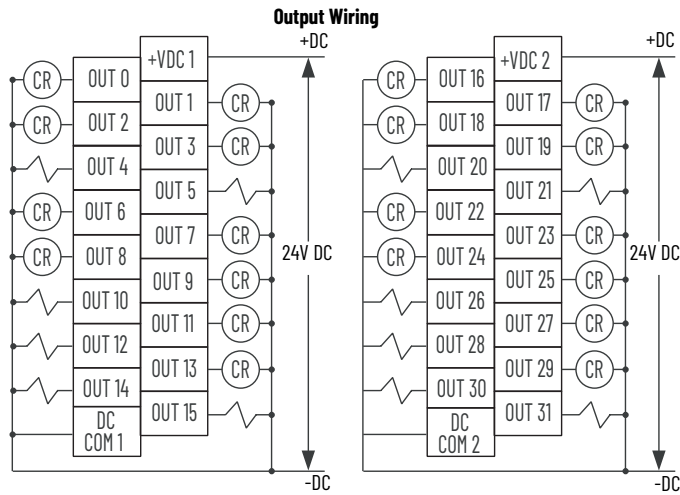

Simplified Output Circuit Diagram

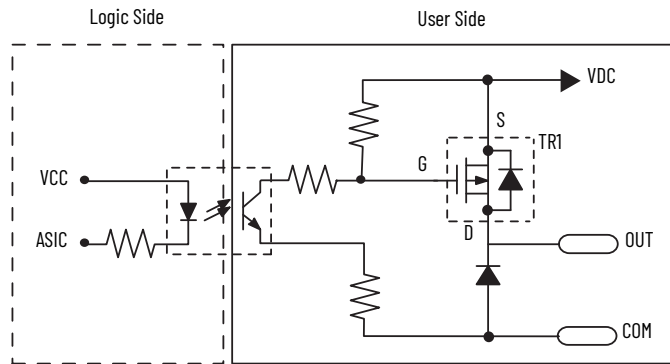

### Technical Specifications - 1769-OB32, 1769-OB32K

Attribute	1769-OB32
Outputs	32 (16 points/group)
Voltage category	24V DC source
Operating voltage range	20.4...26.4V DC
Output delay, on	0.1 ms
Output delay, off	1.0 ms
Current draw @ 5.1V	300 mA
Heat dissipation, max	4.5 W
Off-state leakage current, max <sup>(1)</sup>	1.0 mA @ 26.4V DC
On-state current, min	1.0 mA
On-state voltage drop, max	1.0V DC @ 1 A
Current per point, max	0.5 A @ 60 °C (140 °F) 1.0 A @ 30 °C (86 °F)
Current per module, max	4.0 A @ 60 °C (140 °F) 8.0 A @ 30 °C (86 °F)
Surge current <sup>(2)</sup>	2.0 A for 10 ms, repeatable every 2 s
Isolation voltage	Verified by one of these dielectric tests: 1200V AC for 1 s or 1697V DC for 1 s, output point to bus 75V DC working voltage (IEC Class II reinforced insulation)
Weight, approx	450 g (0.992 lb)

### Technical Specifications - 1769-OB32, 1769-OB32K

Attribute	1769-OB32
Dimensions (HxWxD), approx	118 x 52.5 x 87 mm (4.65 x 2.07 x 3.43 in.) Height with mounting tabs 138 mm (5.43 in.)
Slot width	1.5
Module location	DIN rail or panel mount
Power supply	1769-PA2, 1769-PB2, 1769-PA4, 1769-PB4
Power supply distance rating	6 modules
Terminal screw torque	0.68 N·m (6 lb·in)
Retaining screw torque	0.46 N·m (4.1 lb·in)
Wire size	(22...14 AWG) solid (22...16 AWG) stranded
Wire type	Cu-90 °C (194 °F)
Replacement terminal block	1769-RTBN18 (1 per kit)
Replacement door	Not available
Vendor ID code	1
Product type code	7
Product code	73
Enclosure type rating	None (open style)

- To limit the effects of leakage current through solid-state outputs, a loading resistor can be connected in parallel with your load. Use a 5.6 kW, 1/2 W resistor for transistor outputs, 24V DC operation.
- Use a 1N4004 diode reverse-wired across the load for transistor outputs switching 24V DC inductive loads.

### Temperature Derating - 1769-OB32, 1769-OB32K

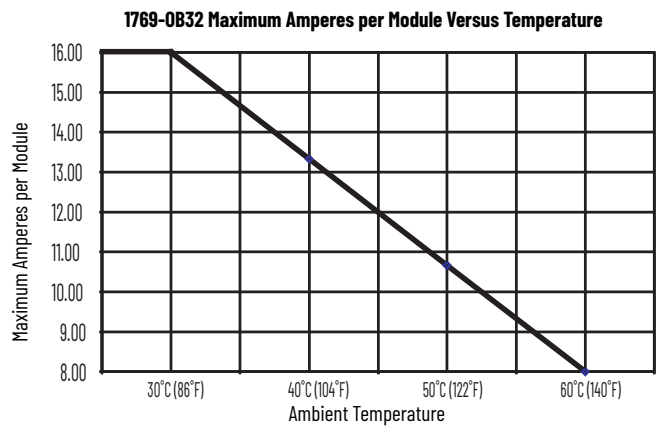
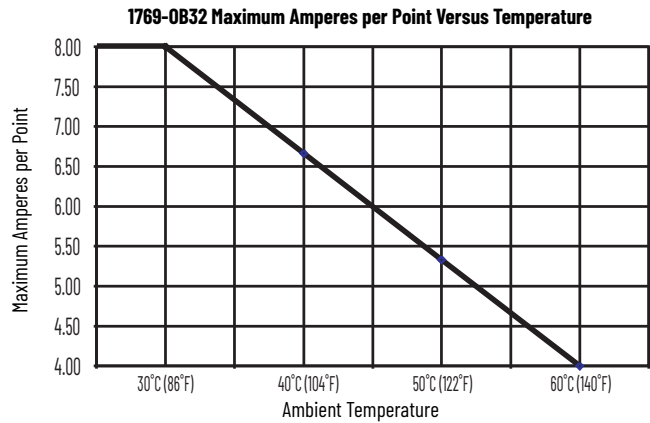

For Environmental Specifications, see [page 2](#).

For Certifications, see [page 3](#).

# 1769-OB32T

## Compact solid-state 24V DC source, terminated output module

Simplified Output Circuit Diagram

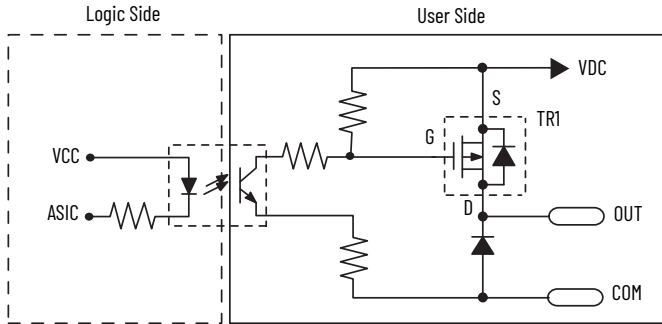

Output Wiring

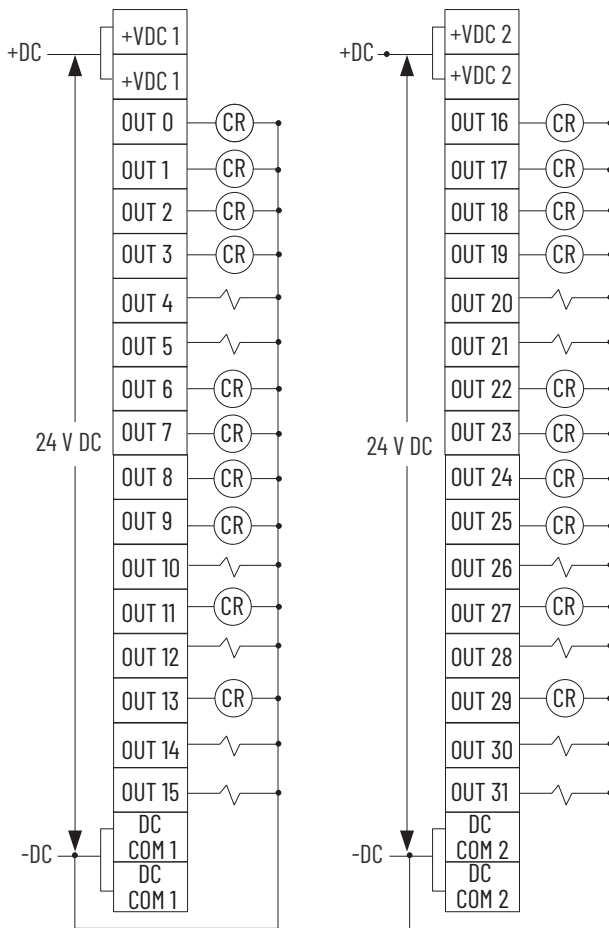

## Technical Specifications - 1769-OB32T

Attribute	1769-OB32T
Outputs	32 terminated (16 points/group)
Voltage category	24V DC source
Operating voltage range	10.2...26.4V DC
Output delay, on	0.5 ms
Output delay, off	4.0 ms
Current draw @ 5.1V	220 mA
Heat dissipation, max	4.76 W
Off-state leakage current, max <sup>(1)</sup>	0.1 mA @ 26.4V DC
On-state current, min	1.0 mA
On-state voltage drop, max	0.3V DC @ 0.5 A
Current per point, max	0.5 A
Current per module, max	4.0 A
Surge current <sup>(2)</sup>	2.0 A for 10 ms, repeatable every 2 s
Isolation voltage	Verified by one of these dielectric tests: 1200V AC for 2 s or 1697V DC for 2 s, output point to bus 75V DC working voltage (IEC Class II reinforced insulation)
Weight, approx	230 g (0.51 lb)
Dimensions (HxWxD), approx	118 x 35 x 87 mm (4.65 x 1.38 x 3.43 in.) Height with mounting tabs 138 mm (5.43 in.)
Slot width	1
Module location	DIN rail or panel mount
Power supply	1769-PA2, 1769-PB2, 1769-PA4, 1769-PB4
Power supply distance rating	8 modules
Terminal screw torque	0.68 N•m (6 lb•in)
Retaining screw torque	0.46 N•m (4.1 lb•in)
Wire size	(22...14 AWG) solid (22...16 AWG) stranded
Wire type	Cu-90 °C (194 °F)
Replacement connector	1746-N3 (1 connector, 40 terminals)
Vendor ID code	1
Product type code	7
Product code	79
Enclosure type rating	None (open style)

- (1) To limit the effects of leakage current through solid-state outputs, a loading resistor can be connected in parallel with your load. Use a 5.6 kW, 1/2 W resistor for transistor outputs; 24V DC operation.
- (2) Use a 1N4004 diode reverse-wired across the load for transistor outputs switching 24V DC inductive loads.

For Environmental Specifications, see [page 2](#).

For Certifications, see [page 3](#).

# 1769-0G16

## Compact TTL output module

Simplified Output Circuit Diagram

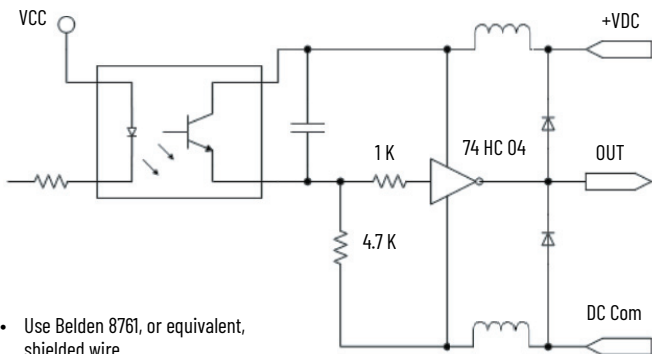

- Use Belden 8761, or equivalent, shielded wire.
- Do not connect more than two wires to any single terminal.
- Do not exceed 10 m (30 ft) with the DC power cable and I/O cables.
- The capacitors that are shown in the diagram must be 0.01 µF and rated for 2000V min.
- User power supply must be rated Class 2 with a 5V DC range of 4.5...5.5V DC.

Output Wiring

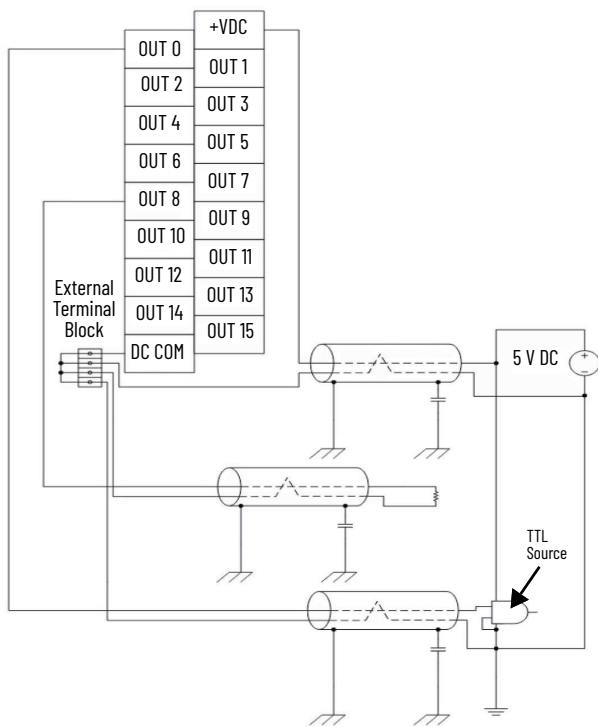

### Low to True Format - 1769-0G16

- 0...0.4V DC = Output on-state is guaranteed
- 0.4...4.5V DC = Output state is not guaranteed
- 4.5...5.5V DC = Output off-state is guaranteed

### Technical Specifications - 1769-0G16

Attribute	1769-0G16
Outputs	16
Voltage category	5V DC TTL (Low=True) <sup>(1)</sup>
Operating voltage range	4.5...5.5V DC 50 mV peak-to-peak ripple max
Output delay, off to on	0.25 ms
Output delay, on to off	0.50 ms
Current draw @ 5.1V	200 mA
Heat dissipation, max	1.2 W
Off-state voltage, typical	4.5...5.5V DC
On-state voltage	0...0.4V DC
Load current, min	0.15 mA
Current per point, max	24 mA
Isolation voltage	Verified by one of these dielectric tests: 1200V AC for 2 s or 1697V DC for 2 s, output point to bus 75V DC working voltage (IEC Class II reinforced insulation)
Weight, approx	250 g (0.55 lb)
Dimensions (HxWxD), approx	118 x 35 x 87 mm (4.65 x 1.38 x 3.43 in.) Height with mounting tabs 138 mm (5.43 in.)
Slot width	1
Module location	DIN rail or panel mount
Power supply	1769-PA2, 1769-PB2, 1769-PA4, 1769-PB4
Power supply distance rating	8 modules
Terminal screw torque	0.68 N•m (6 lb•in)
Retaining screw torque	0.46 N•m (4.1 lb•in)
Wire size	(22...14 AWG) solid (22...16 AWG) stranded
Wire type	Cu-90 °C (194 °F)
Vendor ID code	1
Product type code	7
Product code	78
Input words	1
Output words	1
Configuration words	5
Enclosure type rating	None (open-style)

(1) TTL inputs are inverted (-0.2...0.8 = low voltage = True = On.) Use a NOT instruction in your program to convert to traditional True = High logic.

For Environmental Specifications, see [page 2](#).

For Certifications, see [page 3](#).

# 1769-OV16

## Compact solid-state 24V DC sink output module

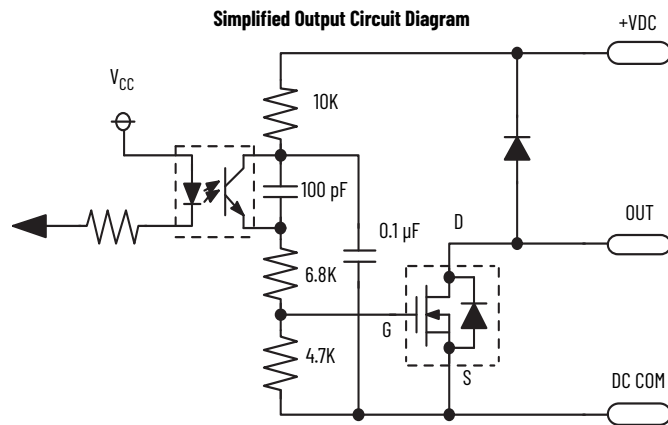

Output Wiring

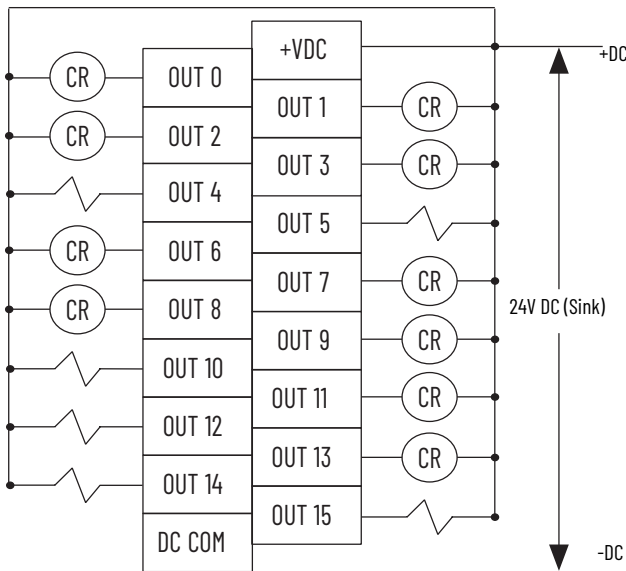

## Technical Specifications - 1769-OV16

Attribute	1769-OV16
Outputs	16 (16 points/group)
Voltage category	24V DC sink
Operating voltage range	20.4...26.4V DC
Output delay, on	0.1 ms
Output delay, off	1.0 ms
Current draw @ 5.1V	200 mA
Heat dissipation, max	2.06 W
Off-state leakage current, max <sup>(1)</sup>	1.0 mA @ 26.4V DC
On-state current, min	1.0 mA
On-state voltage drop, max	1.0V DC @ 1 A
Current per point, max	0.5 A @ 60 °C (140 °F) 1.0 A @ 30 °C (86 °F)
Current per module, max	4.0 A @ 60 °C (140 °F) 8.0 A @ 30 °C (86 °F)
Surge current <sup>(2)</sup>	2.0 A for 10 ms, repeatable every 2 s

## Technical Specifications - 1769-OV16

Attribute	1769-OV16
Isolation voltage	Verified by one of these dielectric tests: 1200V AC for 1 s or 1697V DC for 1 s, output point to bus 75V DC working voltage (IEC Class II reinforced insulation)
Weight, approx	280 g (0.61 lb)
Dimensions (HxWxD), approx	118 x 35 x 87 mm (4.65 x 1.38 x 3.43 in.) Height with mounting tabs 138 mm (5.43 in.)
Slot width	1
Module location	DIN rail or panel mount
Power supply	1769-PA2, 1769-PB2, 1769-PA4, 1769-PB4
Power supply distance rating	8 modules
Terminal screw torque	0.68 N•m (6 lb•in)
Retaining screw torque	0.46 N•m (4.1 lb•in)
Wire size	(22...14 AWG) solid (22...16 AWG) stranded
Wire type	Cu-90 °C (194 °F)
Replacement terminal block	1769-RTBN18 (1 per kit)
Replacement door label	1769-RL1 (2 per kit)
Replacement door	1769-RD (2 per kit)
Vendor ID code	1
Product type code	7
Product code	72
Enclosure type rating	None (open style)

- To limit the effects of leakage current through solid-state outputs, connect a loading resistor parallel with your load. Use a 5.6 kW, 1/2 W resistor for transistor outputs, 24V DC operation.
- Use a 1N4004 diode reverse-wired across the load for transistor outputs switching 24V DC inductive loads.

## Temperature Derating - 1769-OV16

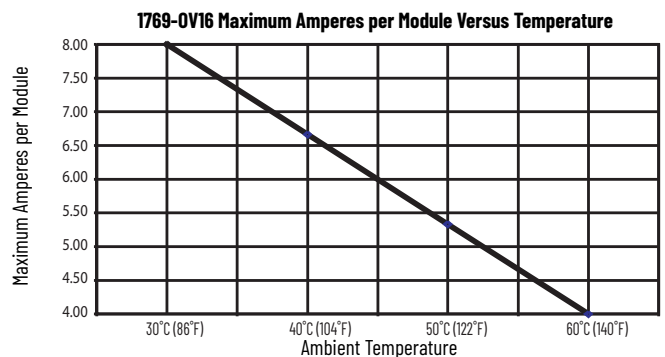
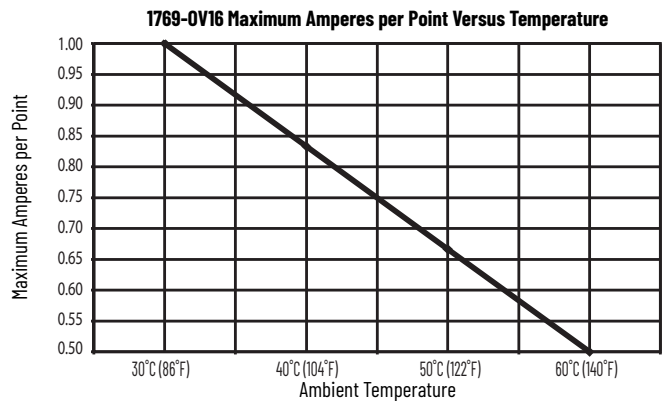

For Environmental Specifications, see [page 2](#).

For Certifications, see [page 3](#).

# 1769-OV32T

## Compact solid-state 24V DC sink, terminated output module

Simplified Output Circuit Diagram

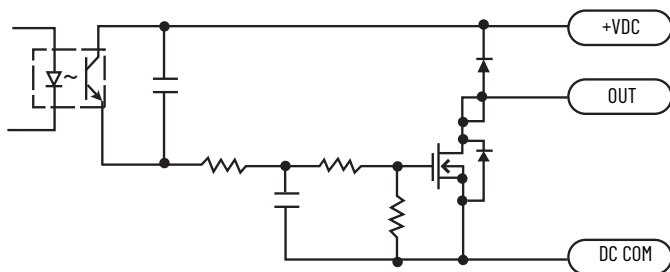

Output Wiring

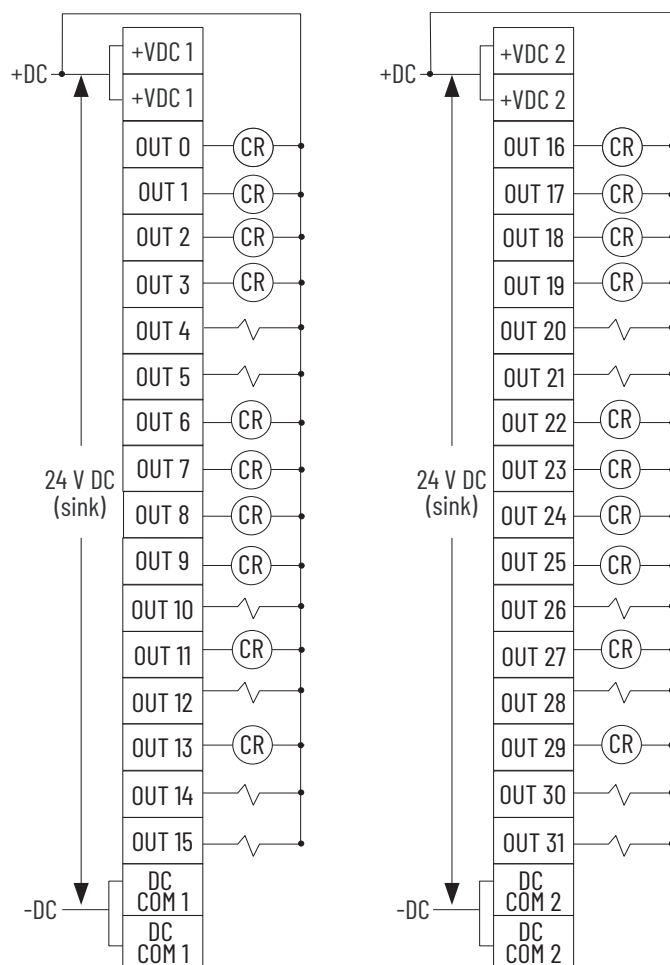

## Technical Specifications - 1769-OV32T

Attribute	1769-OV32T
Outputs	32 terminated (16 points/group)
Voltage category	24V DC sink
Operating voltage range	10.2...26.4V DC
Output delay, on	< 16V, 1.5 ms >= 16V, 1.0 ms
Output delay, off	4.0 ms
Bus current draw	5V DC, 0.220 A 24V DC, 0 A
Heat dissipation, max	4.5 W
Off-state leakage current, max <sup>(1)</sup>	1.0 mA @ 26.4V DC
On-state current, min	1.0 mA
On-state voltage drop, max	0.3V DC @ 0.5 A
Current per point, max	0.5 A
Current per module, max	4.0 A
Surge current <sup>(2)</sup>	2.0 A for 10 ms, repeatable every 2 s
Isolation voltage	Verified by one of these dielectric tests: 1200V AC for 1 s or 1697V DC for 1 s, output point to bus 75V DC working voltage (IEC Class II reinforced insulation)
Weight, approx	450 g (0.992 lb)
Dimensions (HxWxD), approx	118 x 35 x 87 mm (4.65 x 1.38 x 3.43 in.) Height with mounting tabs 138 mm (5.43 in.)
Slot width	1
Module location	DIN rail or panel mount
Power supply	1769-PA2, 1769-PB2, 1769-PA4, 1769-PB4
Power supply distance rating	8 modules
Terminal screw torque	0.68 N•m (6 lb•in)
Retaining screw torque	0.46 N•m (4.1 lb•in)
Wire size	(22...14 AWG) solid (22...16 AWG) stranded
Wire type	Cu-90 °C (194 °F)
Replacement connector	1746-N3 (1 connector, 40 terminals)
Vendor ID code	1
Product type code	7
Product code	75
Enclosure type rating	None (open style)

- (1) To limit the effects of leakage current through solid-state outputs, a loading resistor can be connected in parallel with your load. Use a 5.6 kW, 1/2 W resistor for transistor outputs, 24V DC operation.
- (2) Use a 1N4004 diode reverse-wired across the load for transistor outputs switching 24V DC inductive loads.

For Environmental Specifications, see [page 2](#).

For Certifications, see [page 3](#).

## Contact I/O Modules

These contact modules are available.

<b>I/O Type</b>	<b>Cat. No.</b>	<b>Description</b>	<b>Page</b>
Contact	1769-OW8	Compact AC/DC relay contact module	26
	1769-OW8I, 1769-OW8IK	Compact AC/DC individually isolated, relay contact module	27
	1769-OW16, 1769-OW16K	Compact AC/DC relay contact module	28

# 1769-OW8

## Compact AC/DC relay contact module

Simplified Output Circuit Diagram

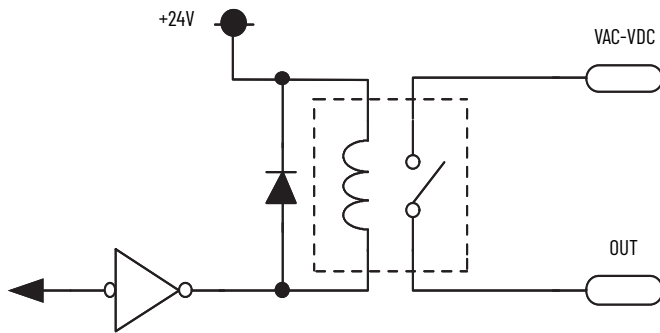

Output Wiring

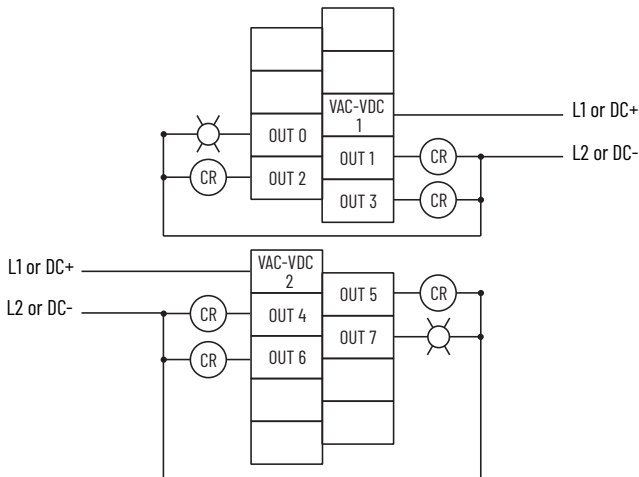

### Technical Specifications - 1769-OW8

Attribute	1769-OW8
Outputs	8 normally open (4 points/group)
Operating voltage range	5...265V AC 5...125V DC
Delay, on	10 ms
Delay, off	10 ms
Current draw @ 5.1V	125 mA
Current draw @ 24V	100 mA
Heat dissipation, max	2.83 W
Off-state leakage, max	0 mA
On-state current, min	10 mA @ 5V DC
Current per point, max	2.5 A
Current per module, max	16 A

### Technical Specifications - 1769-OW8

Attribute	1769-OW8
Isolation voltage	Verified by one of these dielectric tests: 1836V AC for 1 s or 2596V DC for 1 s, output point to bus and group to group 265V AC working voltage (IEC Class II reinforced insulation)
Weight, approx	280 g (0.61 lb)
Dimensions (HxWxD), approx	118 x 35 x 87 mm (4.65 x 1.38 x 3.43 in.) Height with mounting tabs 138 mm (5.43 in.)
Slot width	1
Module location	DIN rail or panel mount
Power supply	1769-PA2, 1769-PB2, 1769-PA4, 1769-PB4
Power supply distance rating	8 modules
Terminal screw torque	0.68 N•m (6 lb•in)
Retaining screw torque	0.46 N•m (4.1 lb•in)
Wire size	(22...14 AWG) solid (22...16 AWG) stranded
Wire type	Cu-90 °C (194 °F)
Replacement terminal block	1769-RTBN10 (1 per kit)
Replacement door label	1769-RL1 (2 per kit)
Replacement door	1769-RD (2 per kit)
Vendor ID code	1
Product type code	7
Product code	86
Enclosure type rating	None (open style)

### Relay Contact Ratings - 1769-OW8

Volts, Max	Continuous Amps per Point, Max	Amperes <sup>(1)</sup>		Voltamperes		NEMA ICS 2-125
		Make	Break	Make	Break	
240V AC	2.5 A	7.5 A	0.75 A	1800VA	180VA	C300
120V AC		15 A	1.5 A			
125V DC	1.0 A	0.22 A <sup>(2)</sup>		28VA		R150
24V DC	2.0 A	1.2 A <sup>(2)</sup>		28VA		—

- (1) If you connect surge suppressors across your external inductive load, you extend the life of the relay contacts.
- (2) For DC voltage applications, you can determine the make/break ampere rating for relay contacts by dividing 28VA by the applied DC voltage. For example, 28VA/48V DC = 0.58 A. For DC voltage applications less than 48V, the make/break ratings for relay contacts cannot exceed 2 A.

For Environmental Specifications, see [page 2](#).

For Certifications, see [page 3](#).

# 1769-OW8I, 1769-OW8IK

## Compact AC/DC individually isolated, relay contact module

Simplified Output Circuit Diagram

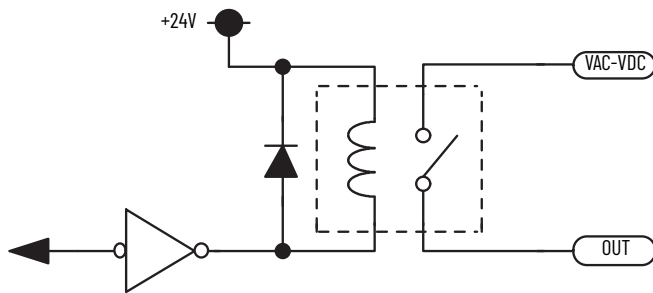

Output Wiring

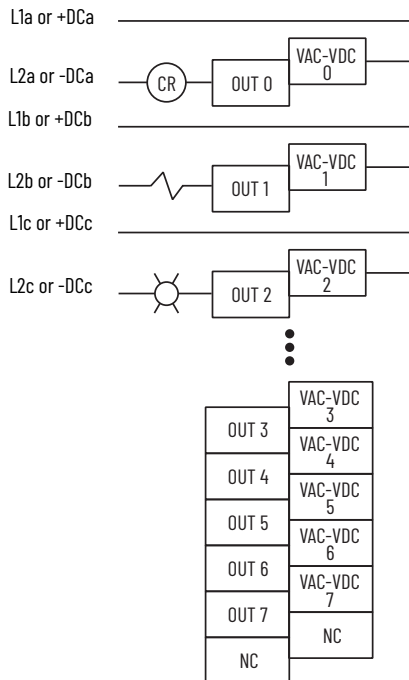

### Technical Specifications - 1769-OW8I, 1769-OW8IK

Attribute	1769-OW8I, 1769-OW8IK
Outputs	8 normally open, individually isolated (4 points/group)
Operating voltage range	5...265V AC 5...125V DC
Delay, on	10 ms
Delay, off	10 ms
Current draw @ 5.1V	125 mA
Current draw @ 24V	100 mA

### Technical Specifications - 1769-OW8I, 1769-OW8IK

Attribute	1769-OW8I, 1769-OW8IK
Heat dissipation, max	2.83 W
Off-state leakage, max	0 mA
On-state current, min	10 mA @ 5V DC
Current per point, max	2.5 A
Current per module, max	16 A
Isolation voltage	Verified by one of these dielectric tests: 1836V AC for 1 s or 2596V DC for 1 s, output point to bus 265V AC working voltage (IEC Class II reinforced insulation) Verified by one of these dielectric tests: 1836V AC for 1 s or 2596V DC for 1 s, group to group 265V AC working voltage (basic insulation) 150V AC working voltage (IEC Class II reinforced insulation)
Weight, approx	290 g (0.64 lb)
Dimensions (HxWxD), Approx	118 x 35 x 87 mm (4.65 x 1.38 x 3.43 in.) Height with mounting tabs 138 mm (5.43 in.)
Slot width	1
Module location	DIN rail or panel mount
Power supply	1769-PA2, 1769-PB2, 1769-PA4, 1769-PB4
Power supply distance rating	8 modules
Terminal screw torque	0.68 N•m (6 lb•in)
Retaining screw torque	0.46 N•m (4.1 lb•in)
Wire size	(22...14 AWG) solid (22...16 AWG) stranded
Wire type	Cu-90 °C (194 °F)
Replacement terminal block	1769-RTBN18 (1 per kit)
Replacement door label	1769-RL1 (2 per kit)
Replacement door	1769-RD (2 per kit)
Vendor ID code	1
Product type code	7
Product code	87
Enclosure type rating	None (open style)

### Relay Contact Ratings - 1769-OW8I, 1769-OW8IK

Volts, Max	Continuous Amps per Point, Max	Amperes <sup>(1)</sup>		Voltamperes		NEMA ICS 2-125
		Make	Break	Make	Break	
240V AC	2.5 A	7.5 A	0.75 A	1800VA	180VA	C300
120V AC		15 A	1.5 A			
125V DC	1.0 A	0.22 A <sup>(2)</sup>		28VA		R150
24V DC	2.0 A	1.2 A <sup>(2)</sup>		28VA		—

- (1) If you connect surge suppressors across your external inductive load, you extend the life of the relay contacts.
- (2) For DC voltage applications, you can determine the make/break ampere rating for relay contacts by dividing 28VA by the applied DC voltage. For example, 28VA/48V DC = 0.58 A. For DC voltage applications less than 48V, the make/break ratings for relay contacts cannot exceed 2 A.

For **Environmental Specifications**, see [page 2](#).

For **Certifications**, see [page 3](#).

# 1769-0W16, 1769-0W16K

## Compact AC/DC relay contact module

Simplified Output Circuit Diagram

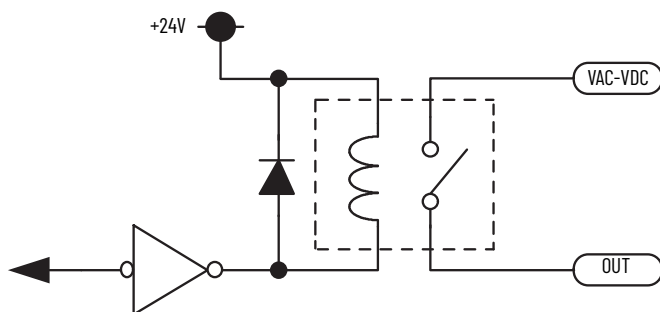

Output Wiring

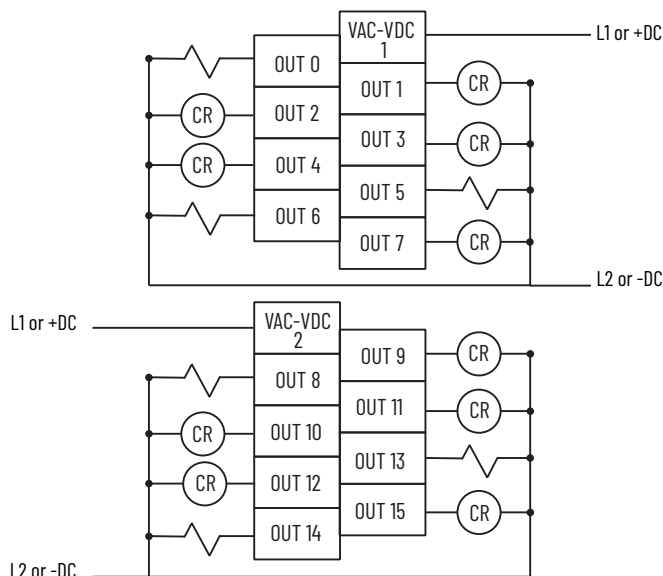

### Technical Specifications - 1769-0W16, 1769-0W16K

Attribute	1769-0W16, 1769-0W16K
Heat dissipation, max	4.75 W
Off-state leakage, max	0 mA
On-state current, min	10 mA @ 5V DC
Current per point, max	2.5 A
Current per module, max	20 A
Isolation voltage	Verified by one of these dielectric tests: 1836V AC for 1 s or 2596V DC for 1 s, output point to bus 265V AC working voltage (IEC Class II reinforced insulation) Verified by one of these dielectric tests: 1836V AC for 1 s or 2596V DC for 1 s, group to group 265V AC working voltage (basic insulation) 150V AC working voltage (IEC Class II reinforced insulation)
Weight, approx	450 g (0.99 lb)
Dimensions (HxWxD), approx	118 x 52.5 x 87 mm (4.65 x 2.07 x 3.43 in.) Height with mounting tabs 138 mm (5.43 in.)
Slot width	1.5
Module location	DIN rail or panel mount
Power supply	1769-PA2, 1769-PB2, 1769-PA4, 1769-PB4
Power supply distance rating	8 modules
Terminal screw torque	0.68 N•m (6 lb•in)
Retaining screw torque	0.46 N•m (4.1 lb•in)
Wire size	(22...14 AWG) solid (22...16 AWG) stranded
Wire type	Cu-90 °C (194 °F)
Replacement terminal block	1769-RTBN18 (1 per kit)
Replacement door label	1769-RL1 (2 per kit)
Replacement door	1769-RD (2 per kit)
Vendor ID code	1
Product type code	7
Product code	85
Enclosure type rating	None (open style)

### Technical Specifications - 1769-0W16, 1769-0W16K

Attribute	1769-0W16, 1769-0W16K
Outputs	16 normally open (8 points/group)
Operating voltage range	5...265V AC 5...125V DC
Delay, on	10 ms
Delay, off	10 ms
Current draw @ 5.1V	205 mA
Current draw @ 24V	180 mA

### Relay Contact Ratings - 1769-0W16, 1769-0W16K

Volts, Max	Continuous Amps per Point, Max	Amperes <sup>(1)</sup>		Voltamperes		NEMA ICS 2-125
		Make	Break	Make	Break	
240V AC	2.5 A	7.5 A	0.75 A	1800VA	180VA	C300
120V AC		15 A	1.5 A			
125V DC	1.0 A	0.22 A <sup>(2)</sup>		28VA		R150
24V DC	2.0 A	1.2 A <sup>(2)</sup>		28VA		—

- (1) If you connect surge suppressors across your external inductive load, you extend the life of the relay contacts.
- (2) For DC voltage applications, you can determine the make/break ampere rating for relay contacts by dividing 28VA by the applied DC voltage. For example, 28VA/48V DC = 0.58 A. For DC voltage applications less than 48V, the make/break ratings for relay contacts cannot exceed 2 A.

For Environmental Specifications, see [page 2](#).

For Certifications, see [page 3](#).

## Analog I/O Modules

Choose analog, thermocouple, or RTD modules for these features:

- Individually configurable channels
- Ability to enable and disable channels individually
- Onboard scaling
- Auto calibration of inputs
- Online configuration
- Selectable input filters
- Overage and underrange detection and indication
- Selectable response to a broken input sensor
- Selectable power source
- Input modules offer both single-ended or differential inputs
- Ability to direct output device operation during an abnormal condition
- High accuracy ratings

The data can be configured on board each module as:

- Engineering units in volts or milliamps.
- Scaled-for-PID.
- Percent of range.
- Raw/Proportional Data for maximum resolution.

These analog I/O modules are available.

I/O Type	Cat. No.	Description	Page
Analog input	1769-IF4, IF4K	Compact voltage/current analog input module	30
	1769-IF4I	Compact voltage/current analog, individually isolated input module	32
	1769-IF4XOF2, 1769-IF4XOF2K	Compact combination input/output analog module	34
	1769-IF4FXOF2F	Compact combination fast input/output analog module	36
	1769-IF8, 1769-IF8K	Compact voltage/current analog input module	38
	1769-IF16C	Compact current analog input module	40
	1769-IF16V	Compact voltage analog input module	41
	1769-IR6	Compact RTD/resistance input module	42
	1769-IT6	Compact Thermocouple/mV input module	45
Analog output	1769-OF2, 1769-OF2K	Compact voltage/current output analog module	47
	1769-OF4, 1769-OF4K	Compact voltage/current output analog module	48
	1769-OF4CI	Compact current output, individually isolated analog module	49
	1769-OF4VI	Compact voltage output, individually isolated analog module	50
	1769-OF8C	Compact current output analog module	51
	1769-OF8V	Compact voltage output analog module	52

# 1769-IF4, 1769-IF4K

## Compact voltage/current analog input module

### Differential Input Wiring

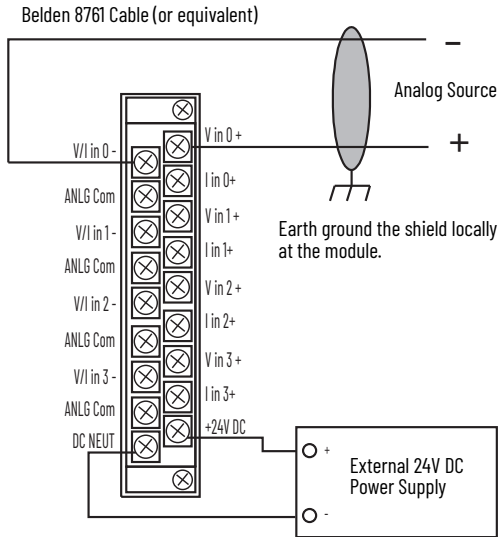

The external power supply must be rated Class 2, with a 24V DC range of 20.4...26.4V DC and 60 mA minimum. Series B and later modules support this option.

### Single-ended Sensor/Transmitter Input Wiring

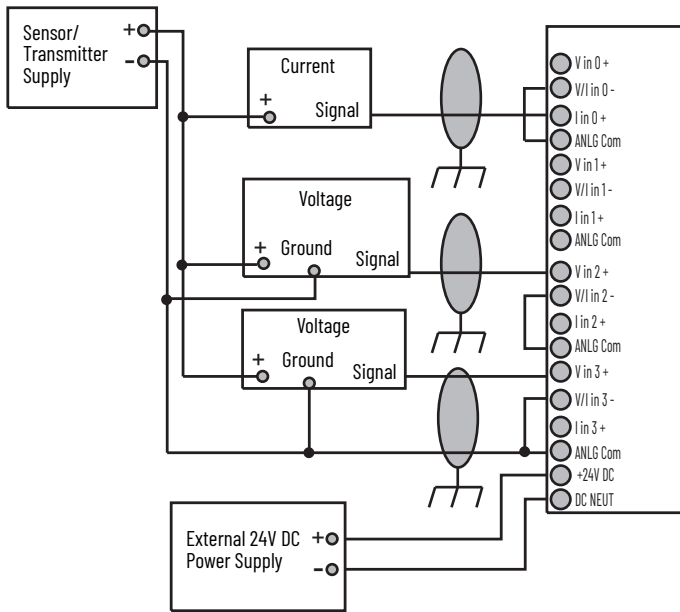

### Mixed Transmitter Input Wiring

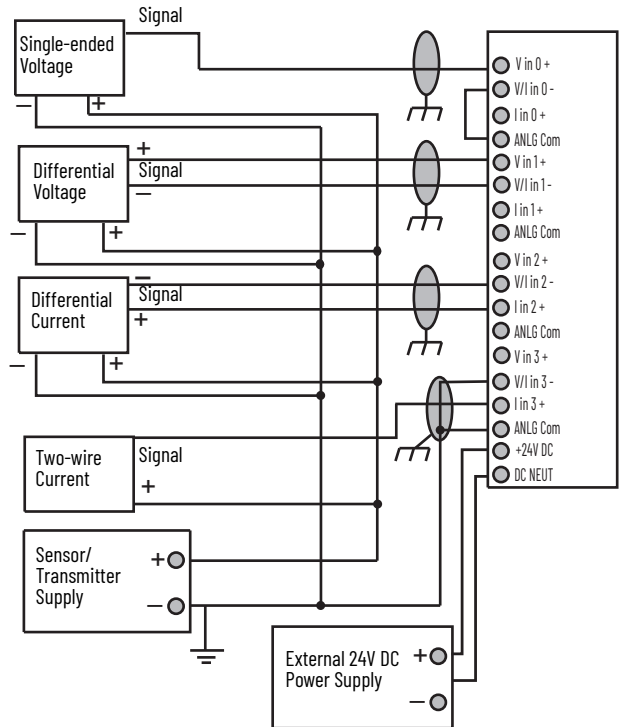

## Technical Specifications – 1769-IF4, 1769-IF4K

Attribute	1769-IF4, 1769-IF4K
Inputs	4 differential or single-ended
Input range	±10V 0...10V 0...5V 1...5V 0...20 mA 4...20 mA
Full-scale range <sup>(1)</sup>	±10.5V -0.5...10.5V -0.5...5.25V 0.5...5.25V, 0...21 mA 3.2...21 mA
Current draw @ 5.1V	120 mA
Current draw @ 24V	60 mA
Heat dissipation, max	2.52 W
Converter type	Delta Sigma
Resolution <sup>(2)</sup>	14 bits (unipolar) 14 bits plus sign (bipolar)
Rated working voltage <sup>(3)</sup>	30V AC/30V DC
Common mode voltage range <sup>(4)</sup>	±10V DC max per channel
Common mode rejection	> 60 dB @ 50 Hz and 60 Hz with the 50 Hz or 60 Hz filter selected, respectively
Normal mode rejection ratio	-50 dB @ 50 Hz and 60 Hz and 60 Hz with the 50 Hz or 60 Hz or 60 Hz filter selected, respectively
Input impedance	Voltage: 220 kΩ Current: 250 Ω
Accuracy <sup>(5)</sup>	Voltage: ±0.2% full-scale @ 25 °C (77 °F) Current: ±0.35% full-scale @ 25 °C (77 °F)
Accuracy drift with temperature	Voltage: ±0.003% per °C Current: ±0.0045% per °C
Nonlinearity	±0.03%
Repeatability <sup>(6)</sup>	±0.03%
Module error	Voltage: ±0.3% Current: ±0.5%
Overload at input terminals, max <sup>(7)</sup>	Voltage: ±30V DC continuous, 0.1 mA Current: ±32 mA continuous, ±7.6V DC
Isolation voltage	500V AC or 710V DC for 1 minute (qualification test), group to bus 30V AC/30V DC working voltage (IEC Class II reinforced insulation)
Weight, approx	300 g (0.65 lb)
Dimensions (HxWxD), approx	118 x 35 x 87 mm (4.65 x 1.38 x 3.43 in.) Height with mounting tabs 138 mm (5.43 in.)
Slot width	1
Module location	DIN rail or panel mount
Power supply	1769-PA2, 1769-PB2, 1769-PA4, 1769-PB4
Optional 24V DC Class 2 power supply voltage range <sup>(8)</sup>	20.4...26.4V DC
Power supply distance rating	8 modules

## Technical Specifications – 1769-IF4, 1769-IF4K

Attribute	1769-IF4, 1769-IF4K
Terminal screw torque	0.68 N•m (6 lb•in)
Retaining screw torque	0.46 N•m (4.1 lb•in)
Wire size	(22...14 AWG) solid (22...16 AWG) stranded
Wire type	Cu-90 °C (194 °F)
Replacement terminal block	1769-RTBN18 (1 per kit)
Replacement door label	1769-RL2 series B (2 per kit)
Replacement door	1769-RD (2 per kit)
Vendor ID code	1
Product type code	10
Product code	35
Enclosure type rating	None (open-style)

- (1) The over- or underrange flag comes on when the normal operating range (over/under) is exceeded. The module continues to convert the analog input up to the maximum full-scale range. The flag automatically resets when within the normal operating range.
- (2) Resolution is dependent upon your filter selection. The maximum resolution is achieved with either the 50 Hz or 60 Hz filter selected.
- (3) Rated working voltage is the maximum continuous voltage that can be applied at the input terminal, including the input signal and the value that floats above ground potential. For example, a 10V DC input signal and 20V DC potential above ground at the input terminals.
- (4) For proper operation, both the plus and minus input terminals must be within ±10V DC of analog common.
- (5) Includes offset, gain, nonlinearity, and repeatability error terms.
- (6) Repeatability is the ability of the input module to register the same reading in successive measurements for the same input signal.
- (7) Damage can occur to the input circuit if this value is exceeded.
- (8) If the optional 24V DC Class 2 power supply is used, the 24V DC current draw from the bus is 0 mA.

## Response Speed – 1769-IF4, 1769-IF4K

Filter Frequency	Cutoff Frequency	Step Response	Channel Update
50 Hz	13.1 Hz	60 ms	22 ms
60 Hz	15.7 Hz	50 ms	19 ms
250 Hz	65.5 Hz	12 ms	6 ms
500 Hz	131 Hz	6 ms	4 ms

For Environmental Specifications, see [page 2](#).

For Certifications, see [page 3](#).

# 1769-IF4I

## Compact voltage/current analog, individually isolated input module

**Differential Input Wiring**

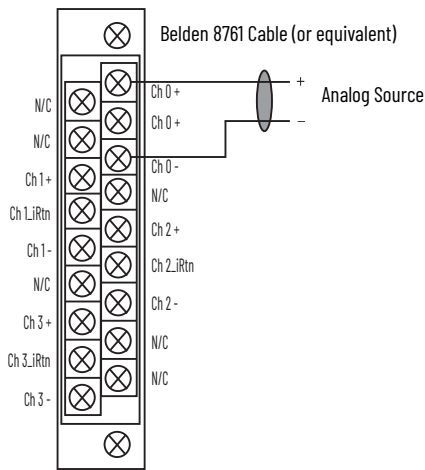

**Single-ended Sensor/Transmitter Input Wiring**

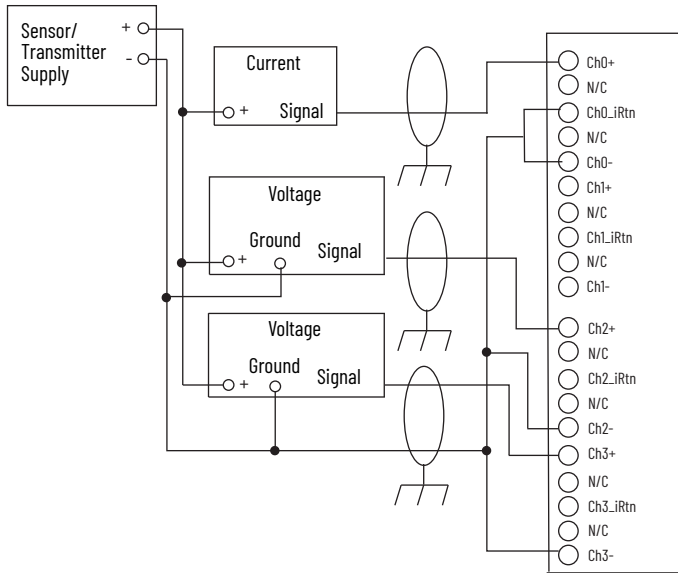

**Mixed Transmitter Input Wiring**

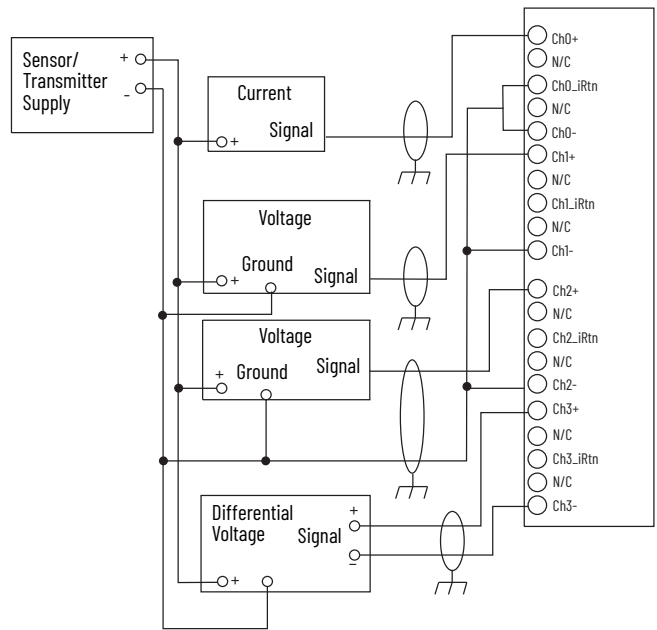

## Technical Specifications – 1769-IF4I

Attribute	1769-IF4I
Inputs	4 isolated differential
Input range	±10V 0...10V 0...5V 1...5V 0...20 mA 4...20 mA
Full-scale range <sup>(1)</sup>	±10.5V -0.5...10.5V -0.5...5.25V 0.5...5.25V 0...21 mA 3.2...21 mA
Bus current draw	5V DC, 140 mA 24V DC, 110 mA
Heat dissipation, max	3.0 W
Converter type	Delta Sigma
Resolution <sup>(2)</sup>	16 bits (unipolar), 15 bits plus sign (bipolar)
Rated working voltage <sup>(3)</sup>	30V AC/30V DC
Common mode voltage range <sup>(4)</sup>	±10V DC max per channel
Common mode rejection	> 60 dB @ 50 Hz and 60 Hz with the 10 Hz filter selected
Normal mode rejection ratio	-50 dB @ 50 Hz and 60 Hz with the 10 Hz filter selected
Input impedance	Voltage: 1 MΩ Current: 249 Ω
Accuracy <sup>(5)</sup>	Voltage: ±0.2% full-scale @ 25 °C (77 °F) Current: ±0.35% full-scale @ 25 °C (77 °F)
Accuracy drift with temperature	Voltage: ±0.003% per °C, Current: ±0.0045% per °C
Nonlinearity	±0.03%
Repeatability <sup>(6)</sup>	±0.03%
Module error	Voltage: ±0.3% Current: ±0.5%
Overload at input terminals, max <sup>(7)</sup>	Voltage: ±24V DC continuous, 0.1 mA Current: ±28 mA continuous, ±7.6V DC
Isolation voltage	500V AC or 710V DC for 1 minute (qualification test), group to bus 30V AC/30V DC working voltage (IEC Class II reinforced insulation) 500V AC or 710V DC for 1 minute or 250V continuous (optical and magnetic), channel to rack and channel to channel
Weight, approx	300 g (0.65 lb)
Dimensions (HxWxD), approx	118 x 35 x 87 mm (4.65 x 1.38 x 3.43 in.) Height with mounting tabs 138 mm (5.43 in.)
Slot width	1
Module location	DIN rail or panel mount
Power supply	1769-PA2, 1769-PB2, 1769-PA4, 1769-PB4
Power supply distance rating	8 modules

## Technical Specifications – 1769-IF4I

Attribute	1769-IF4I
Terminal screw torque	0.68 N•m (6 lb•in)
Retaining screw torque	0.46 N•m (4.1 lb•in)
Wire size	(22...14 AWG) solid (22...16 AWG) stranded
Wire type	Cu-90 °C (194 °F)
Replacement terminal block	1769-RTBN18 (1 per kit)
Replacement door label	1769-RL2 series B (2 per kit)
Replacement door	1769-RD (2 per kit)
Vendor ID code	1
Product type code	10
Product code	44
Enclosure type rating	None (open-style)

- (1) The over- or underrange flag comes on when the normal operating range (over/under) is exceeded. The module continues to convert the analog input up to the maximum full-scale range. The flag automatically resets when within the normal operating range.
- (2) Resolution is dependent upon your filter selection. The maximum resolution is achieved with either the 50 Hz or 60 Hz filter selected.
- (3) Rated working voltage is the maximum continuous voltage that can be applied at the input terminal, including the input signal and the value that floats above ground potential. For example, a 10V DC input signal and 20V DC potential above ground at the input terminal.
- (4) For proper operation, both the plus and minus input terminals must be within ±10V DC of analog common.
- (5) Includes offset, gain, nonlinearity, and repeatability error terms.
- (6) Repeatability is the ability of the input module to register the same reading in successive measurements for the same input signal.
- (7) Damage can occur to the input circuit if this value is exceeded.

## Response Speed - 1769-IF4I

Filter Frequency	Channel Update
28.5 Hz	108 ms
50 Hz	62 ms
60 Hz	52 ms
300 Hz	12 ms
360 Hz	10 ms

For **Environmental Specifications**, see [page 2](#).

For **Certifications**, see [page 3](#).

# 1769-IF4XOF2, 1769-IF4XOF2K

## Compact combination input/output analog module

**Analog Output Wiring**

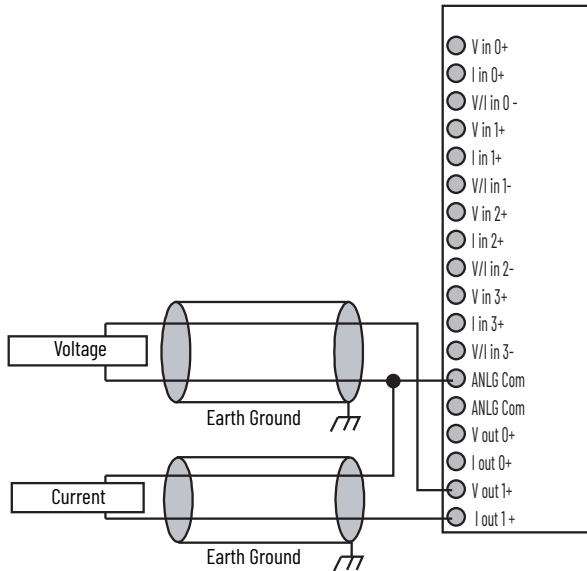

**Differential Input Wiring**

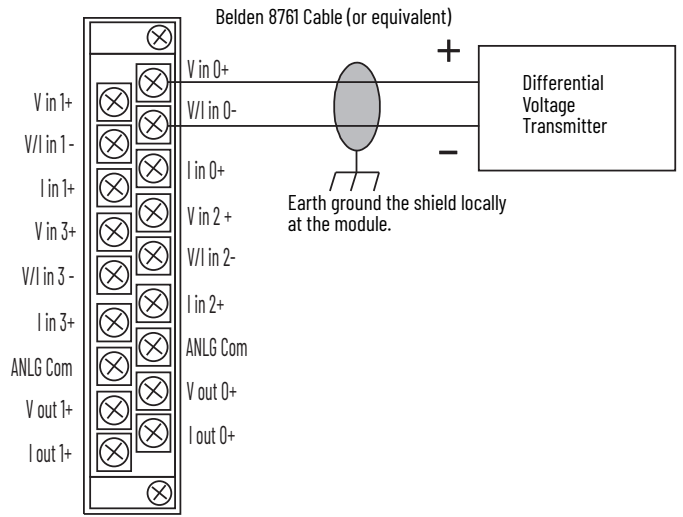

**Single-ended Sensor/Transmitter Input Wiring**

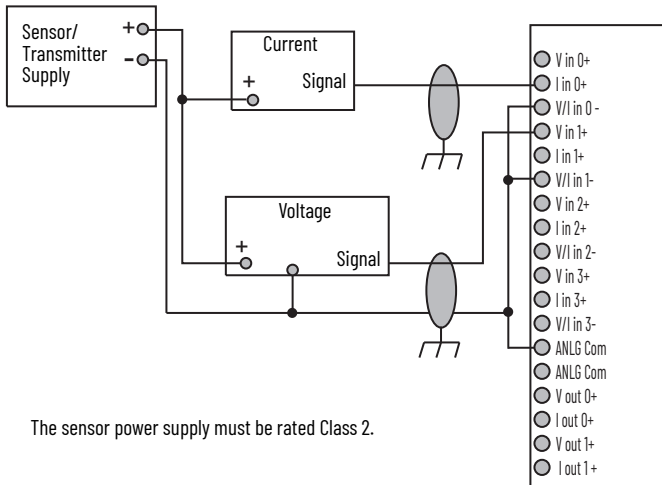

The sensor power supply must be rated Class 2.

**Mixed Transmitter Input Wiring**

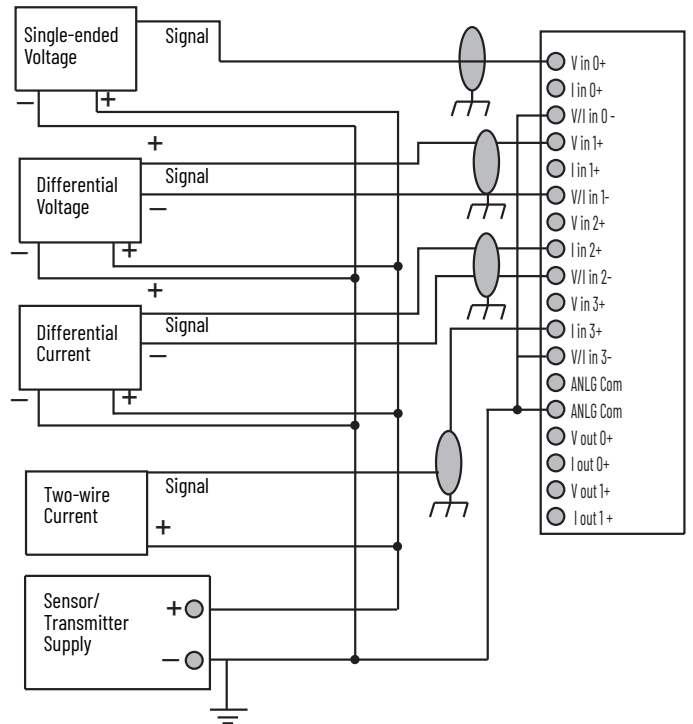

**Technical Specifications - 1769-IF4XOF2, 1769-IF4XOF2K**

Attribute	1769-IF4XOF2, 1769-IF4XOF2K
Current draw @ 5.1V	120 mA
Current draw @ 24V	160 mA
Heat dissipation, max	3.03 W
Weight, approx	290 g (0.64 lb)
Dimensions (HxWxD), approx	118 x 35 x 87 mm (4.65 x 1.38 x 3.43 in.) Height with mounting tabs 138 mm (5.43 in.)
Slot width	1
Module location	DIN rail or panel mount
Power supply	1769-PA2, 1769-PB2, 1769-PA4, 1769-PB4
Power supply distance rating	8 modules
Terminal screw torque	0.68 N•m (6 lb•in)
Retaining screw torque	0.46 N•m (4.1 lb•in)
Wire size	(22...14 AWG) solid (22...16 AWG) stranded
Wire type	Cu-90 °C (194 °F)
Replacement terminal block	1769-RTBN18 (1 per kit)
Replacement door label	1769-RL2 series B (2 per kit)
Replacement door	1769-RD (2 per kit)
Vendor ID code	1
Product type code	10
Product code	33
Enclosure type rating	None (open-style)

**Input Specifications - 1769-IF4XOF2, 1769-IF4XOF2K**

Attribute	1769-IF4XOF2, 1769-IF4XOF2K
Inputs	4 differential or single-ended
Input range	0...10V 0...20 mA
Full-scale range <sup>(1)</sup>	0...10.5V 0...21 mA
Converter type	Successive approximation
Resolution <sup>(2)</sup>	8 bits plus sign
Response speed per channel	5 ms
Rated working voltage <sup>(3)</sup>	30V AC/30V DC
Common mode voltage range <sup>(4)</sup>	10V DC max per channel
Common mode rejection	> 60 dB @ 50 Hz and 60 Hz with the 10 Hz filter selected
Input impedance	Current: 150 Ω Voltage: 150 kΩ
Accuracy <sup>(5)</sup>	Current: ±0.6% full-scale @ 25 °C (77 °F) Voltage: ±0.7% full-scale @ 25 °C (77 °F)
Overall accuracy	Current: ±0.8% full-scale @ 0...60 °C (32...140 °F) Voltage: ±0.9% full-scale @ 0...60 °C (32...140 °F)
Accuracy drift with temperature	Current: ±0.006% per °C Voltage: ±0.006% per °C
Nonlinearity	±0.4%
Repeatability <sup>(6)</sup>	±0.4%
Overload at input terminals, max <sup>(7)</sup>	Current: ±32 mA continuous, ±5V DC Voltage: ±20V DC continuous, 0.1 mA
Isolation voltage	500V AC or 710V DC for 1 minute (qualification test), group to bus 30V AC/30V DC working voltage (IEC Class II reinforced insulation)

- (1) The over- or underrange flag comes on when the normal operating range (over/under) is exceeded. The module continues to convert the analog input up to the maximum full-scale range. The flag automatically resets when within the normal operating range.
- (2) Resolution is dependent upon your filter selection. The maximum resolution is achieved with either the 50 Hz or 60 Hz filter selected.
- (3) Rated working voltage is the maximum continuous voltage that can be applied at the input terminal, including the input signal and the value that floats above ground potential. For example, a 10V DC input signal and 20V DC potential above ground at the input terminal.

- (4) For proper operation, both the plus and minus input terminals must be within ±10V DC of analog common.
- (5) Includes offset, gain, nonlinearity, and repeatability error terms.
- (6) Repeatability is the ability of the input module to register the same reading in successive measurements for the same input signal.
- (7) Damage can occur to the input circuit if this value is exceeded.

**Output Specifications - 1769-IF4XOF2, 1769-IF4XOF2K**

Attribute	1769-IF4XOF2, 1769-IF4XOF2K
Outputs	2 single-ended
Output range	0...10V 0...20 mA
Full-scale range <sup>(1)</sup>	0...10.5V 0...21 mA
Converter type	Resistor string
Resolution	8 bits plus sign
Response speed per channel	0.3 ms for rated resistance and rated inductance 3.0 ms for rated capacitance
Current load on voltage output, max	10 mA
Resistive load on current output	0...300 Ω (includes wire resistance)
Load range on voltage output	> 1 kΩ
Inductive load, max	Current: 0.1 mH Voltage: 1 μF
Accuracy <sup>(2)</sup>	Current: ±0.5% full-scale @ 25 °C (77 °F) Voltage: ±0.5% full-scale @ 25 °C (77 °F)
Overall accuracy	Current: ±1.0% full-scale @ 0...60 °C (32...140 °F) Voltage: ±0.6% full-scale @ 0...60 °C (32...140 °F)
Accuracy drift with temperature	Current: ±0.01% per °C Voltage: ±0.01% per °C
Output ripple <sup>(3)</sup>	±0.05% @ 0...50 kHz
Nonlinearity	±0.4%
Repeatability <sup>(4)</sup>	±0.05%
Output impedance	10 kΩ
Open and short-circuit protection	Yes
Short-circuit, max	40 mA
Open circuit, max	15V
Output response at system power-up and power down	+2.0...-1.0V DC spike for < 6 ms
Isolation voltage	500V AC or 710V DC for 1 min (qualification test), output group to bus 30V AC/30V DC working voltage (IEC Class II reinforced insulation)

- (1) The over- or underrange flag comes on when the normal operating range (over/under) is exceeded. The module continues to convert the analog input up to the maximum full-scale range. The flag automatically resets when within the normal operating range.
- (2) Includes offset, gain, nonlinearity, and repeatability error terms.
- (3) Output ripple is the amount that a fixed output varies with time, which assumes a constant load and temperature.
- (4) Repeatability is the ability of the input module to register the same reading in successive measurements for the same input signal.

**Response Speed - 1769-IF4XOF2, 1769-IF4XOF2K**

Fixed Filter Frequency	Filter Cutoff Frequency	Step Response % Complete	Step Response Time
2.7 kHz	2.7 kHz	63%	59 μs
2.7 kHz	2.7 kHz	90%	136 μs (nom)

For Environmental Specifications, see [page 2](#).

For Certifications, see [page 3](#).

# 1769-IF4FXOF2F

## Compact combination fast input/output analog module

**Simplified Input Circuit Diagram**

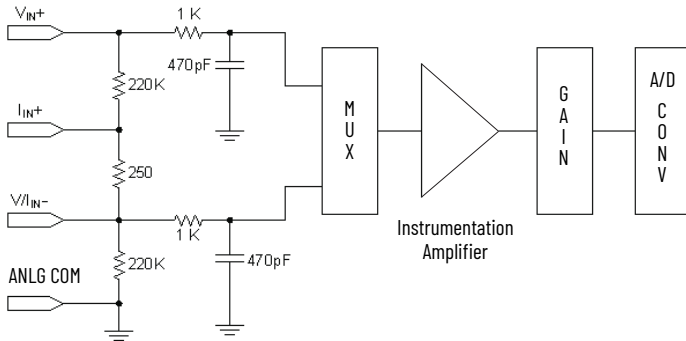

**Simplified Output Circuit Diagram**

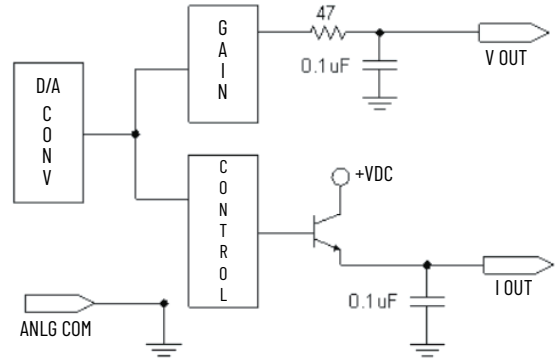

**Single-ended Sensor/Transmitter Input Wiring**

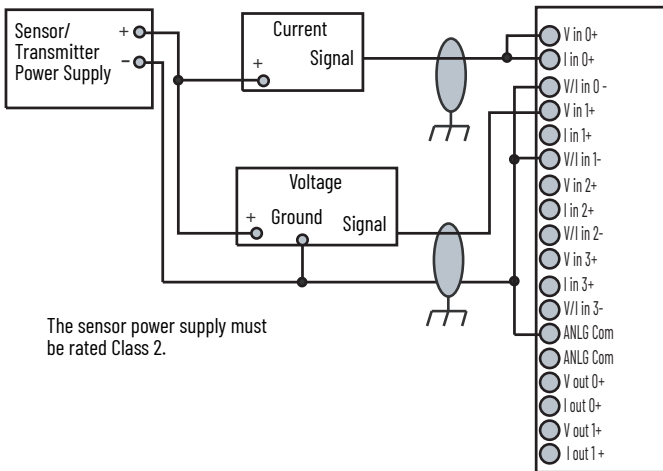

**Differential Input Wiring**

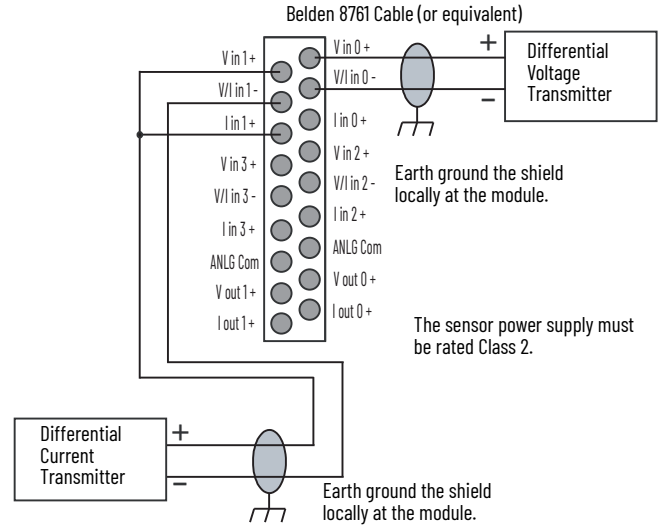

**Mixed Transmitter Input Wiring**

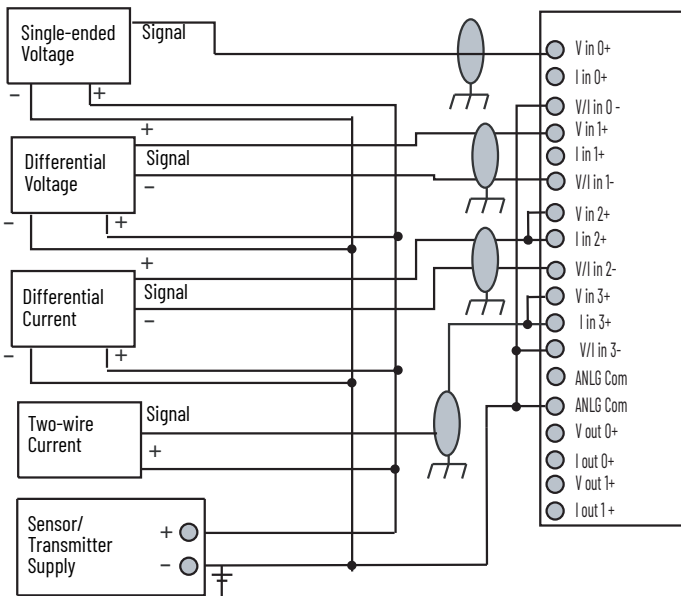

**Analog Output Wiring**

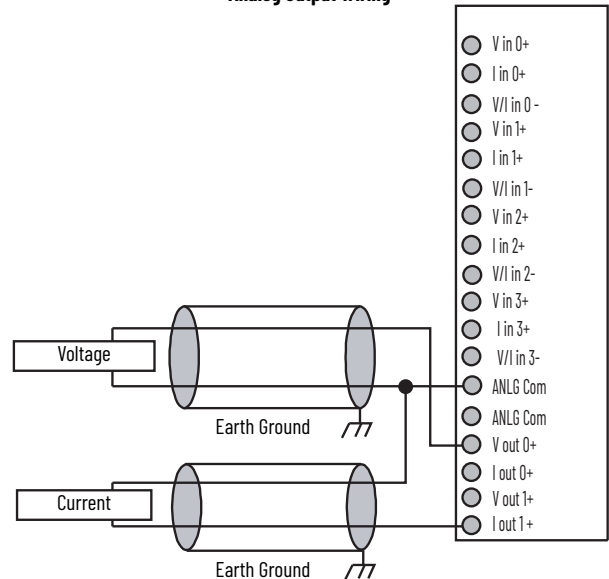

## Technical Specifications – 1769-IF4FXOF2F

Attribute	1769-IF4FXOF2F
Current draw @ 5.1V	220 mA
Current draw @ 24V	120 mA
Heat dissipation, max	3.39 W
Weight, approx	290 g (0.64 lb)
Dimensions (HxWxD), approx	118 x 35 x 87 mm (4.65 x 1.38 x 3.43 in.) Height with mounting tabs 138 mm (5.43 in.)
Slot width	1
Module location	DIN rail or panel mount
Power supply	1769-PA, 2 1769-PB2, 1769-PA4, 1769-PB4
Power supply distance rating	8 modules
Terminal screw torque	0.68 N•m (6 lb•in)
Retaining screw torque	0.46 N•m (4.1 lb•in)
Wire size	(22...14 AWG) solid (22...16 AWG) stranded
Wire type	Cu-90 °C (194 °F)
Replacement terminal block	1769-RTBN18 (1 per kit)
Replacement door label	1769-RL2 series B (2 per kit)
Replacement door	1769-RD (2 per kit)
Vendor ID code	1
Product type code	10
Product code	43
Input words	10
Output words	4
Configuration words	42
Enclosure type rating	None (open-style)

## 1769-IF4FXOF2F Input Specifications

Attribute	1769-IF4FXOF2F
Inputs	4 differential or single-ended
Input range	±10V, 0...10V, 0...5V, 1...5V, 0...20 mA, 4...20 mA
Full-scale range <sup>(1)</sup>	±10.5V, -0.5...10.5V, -0.5...5.25V, 0.5...5.25V, 0...21 mA, 3.2...21 mA
Converter type	Successive approximation
Resolution <sup>(2)</sup>	14 bits (unipolar), 14 bits plus sign (bipolar)
Rated working voltage <sup>(3)</sup>	30V AC/30V DC
Common mode voltage range <sup>(4)</sup>	±10V DC max per channel
Common mode rejection	> 70 dB @ 50 Hz and 60 Hz with the 10 Hz filter selected
Input impedance	Current: 250 Ω, Voltage: 220 kΩ
Accuracy <sup>(5)</sup>	Current: ±0.2% full-scale @ 25 °C (77 °F) Voltage: ±0.15% full-scale @ 25 °C (77 °F)
Accuracy drift with temperature	Current: ±0.0045% per °C Voltage: ±0.003% per °C
Nonlinearity	±0.03%
Repeatability <sup>(6)</sup>	±0.03%
Module error	Current: ±0.3%, Voltage: ±0.2%
Overload at input terminals, max <sup>(7)</sup>	Current: ±32 mA continuous, ±7.6V DC Voltage: ±30V DC continuous, 0.1 mA
Isolation voltage	500V AC or 710V DC for 1 minute (qualification test), group to bus, 30V AC/30V DC working voltage (IEC Class II reinforced insulation)

- (1) The over- or underrange flag comes on when the normal operating range (over/under) is exceeded. The module continues to convert the analog input up to the maximum full-scale range. The flag automatically resets when within the normal operating range.
- (2) Resolution is dependent upon your filter selection. The maximum resolution is achieved with either the 50 Hz or 60 Hz filter selected.
- (3) Rated working voltage is the maximum continuous voltage that can be applied at the input terminal, including the input signal and the value that floats above ground potential. For example, a 10V DC input signal and 20V DC potential above ground at the input terminal.
- (4) For proper operation, both the plus and minus input terminals must be within ±10V DC of analog common.

- (5) Includes offset, gain, nonlinearity, and repeatability error terms.
- (6) Repeatability is the ability of the input module to register the same reading in successive measurements for the same input signal.
- (7) Damage can occur to the input circuit if this value is exceeded.

## 1769-IF4FXOF2F Output Specifications

Attribute	1769-IF4FXOF2F
Outputs	2 single-ended
Output range	±10V, 0...10V, 0...5V, 1...5V, 0...20 mA, 4...20 mA
Full-scale range <sup>(1)</sup>	±10.5V, -0.5...10.5V, -0.5...5.25V, 0.5...5.25V, 0...21 mA, 3.2...21 mA
Resolution	13 bits (unipolar), 13 bits plus sign (bipolar)
Conversion rate (all channels), max	1 ms
Step response to 63% <sup>(2)</sup>	2.0 ms
Current load on voltage output, max	10 mA
Resistive load	Current: 0...500 Ω (includes wire resistance) Voltage: 1 kΩ or greater
Inductive load, max	Current: 0.1 mA, Voltage: 1 μF
Field calibration	None required
Accuracy <sup>(3)</sup>	±0.2% full-scale @ 25 °C (77 °F)
Accuracy drift with temperature	Current: ±0.0058% per °C Voltage: ±0.0086% per °C
Output ripple <sup>(4)</sup>	±0.05% @ 0...50 kHz
Nonlinearity	±0.05%
Repeatability <sup>(5)</sup>	±0.05%
Module error	Current: ±0.4%, Voltage: ±0.3%
Open and short-circuit protection	Yes
Short-circuit protection, max	50 mA
Output overvoltage protection	Yes
Rated working voltage <sup>(6)</sup>	30V AC/30V DC
Isolation voltage	500V AC or 710V DC for 1 min (qualification test), output group to bus 30V AC/30V DC working voltage (IEC Class II reinforced insulation)

- (1) The over- or underrange flag comes on when the normal operating range (over/under) is exceeded. The module continues to convert the analog input up to the maximum full-scale range. The flag automatically resets when within the normal operating range.
- (2) Step response is the time between when the D/A converter was instructed to go from minimum to full range until the device is at 63% of full range.
- (3) Includes offset, gain, nonlinearity, and repeatability error terms.
- (4) Output ripple is the amount that a fixed output varies with time, which assumes a constant load and temperature.
- (5) Repeatability is the ability of the input module to register the same reading in successive measurements for the same input signal.
- (6) Rated working voltage is the maximum continuous voltage that can be applied at the input terminal, including the input signal and the value that floats above ground potential. For example, a 10V DC input signal and 20V DC potential above ground at the input terminal.

## Response Speed – 1769-IF4FXOF2F

Filter Frequency	Channel Step Response
5 Hz	802 ms
10 Hz	401 ms
50 Hz	81 ms
60 Hz	65 ms
100 Hz	42 ms
250 Hz	17 ms
500 Hz	10 ms
1000 Hz	5 ms

For Environmental Specifications, see [page 2](#).

For Certifications, see [page 3](#).

# 1769-IF8, 1769-IF8K

## Compact voltage/current analog input module

### Differential Input Wiring

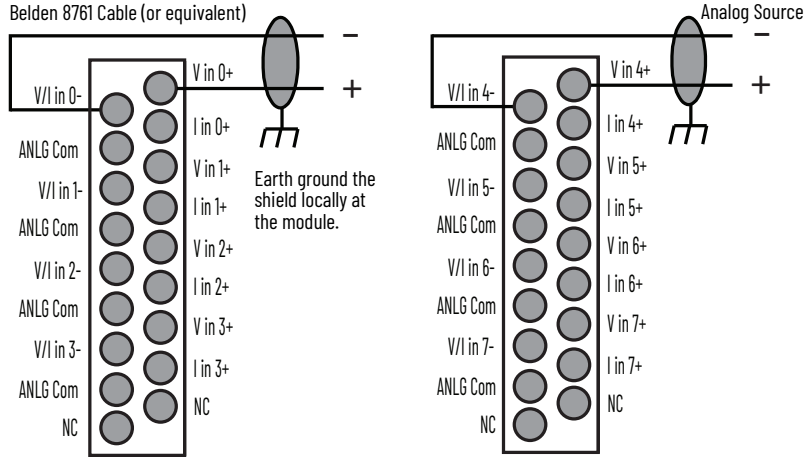

### Single-ended Sensor/Transmitter Input Wiring

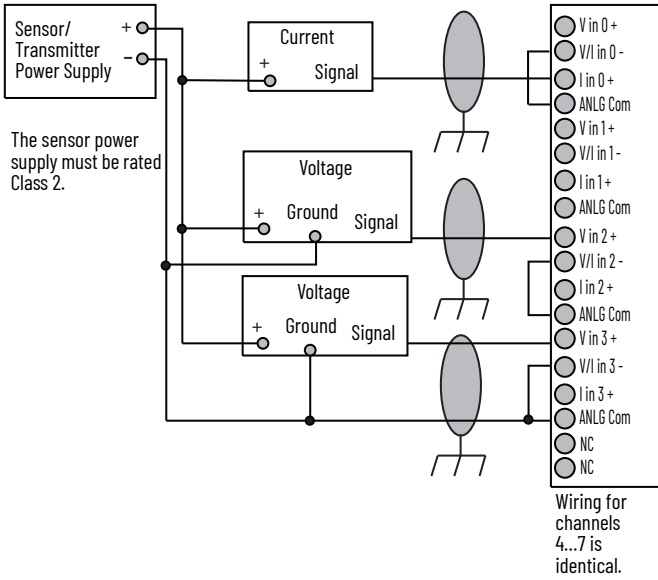

### Mixed Transmitter Wiring

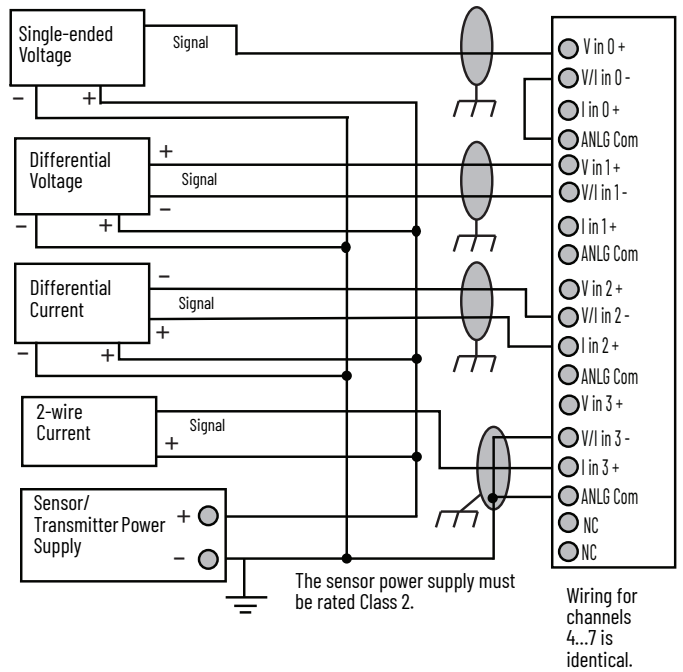

## Technical Specifications – 1769-IF8, 1769-IF8K

Attribute	1769-IF8, 1769-IF8K
Inputs	8 differential or single-ended
Input range	±10V 0...10V 0...5V 1...5V 0...20 mA 4...20 mA
Full-scale range <sup>(1)</sup>	±10.5V -0.5...10.5V -0.5...5.25V 0.5...5.25V 0...21 mA 3.2...21 mA
Current draw @ 5.1V	120 mA
Current draw @ 24V	70 mA
Converter type	Delta Sigma
Heat dissipation, max	3.24 W
Resolution <sup>(2)</sup>	16 bits (unipolar), 15 bits plus sign (bipolar)
Rated working voltage <sup>(3)</sup>	30V AC/30V DC
Common mode voltage range <sup>(4)</sup>	±10V DC max per channel
Common mode rejection	> 60 dB @ 50 Hz and 60 Hz with the 10 Hz filter selected
Normal mode rejection ratio	-50 dB @ 50 Hz and 60 Hz with the 10 Hz filter selected
Input impedance	Voltage: 220 kΩ, Current: 250 Ω
Accuracy <sup>(5)</sup>	Voltage: ±0.2% full-scale @ 25 °C (77 °F) Current: ±0.35% full-scale @ 25 °C (77 °F)
Accuracy drift with temperature	Voltage: ±0.003% per °C Current: ±0.0045% per °C
Nonlinearity	±0.03%
Repeatability <sup>(6)</sup>	±0.03%
Module error	Voltage: ±0.3% Current: ±0.5%
Overload at input terminals, max <sup>(7)</sup>	Voltage: ±30V DC continuous, 0.1 mA Current: ±32 mA continuous, ±7.6V DC
Isolation voltage	500V AC or 710V DC for 1 minute (qualification test), group to bus 30V AC/30V DC working voltage (IEC Class II reinforced insulation)
Weight, approx	450 g (0.99 lb)
Dimensions (HxWxD), Approx	118 x 52.5 x 87 mm (4.65 x 2.07 x 3.43 in.) Height with mounting tabs 138 mm (5.43 in.)
Slot width	1.5
Module location	DIN rail or panel mount
Power supply	1769-PA2, 1769-PB2, 1769-PA4, 1769-PB4
Power supply distance rating	8 modules

## Technical Specifications – 1769-IF8, 1769-IF8K

Attribute	1769-IF8, 1769-IF8K
Terminal screw torque	0.68 N•m (6 lb•in)
Retaining screw torque	0.46 N•m (4.1 lb•in)
Wire size	(22...14 AWG) solid (22...16 AWG) stranded
Wire type	Cu-90 °C (194 °F)
Replacement terminal block	1769-RTBN18 (1 per kit)
Replacement door	Not available
Vendor ID code	1
Product type code	10
Product code	38
Enclosure type rating	None (open-style)

- (1) The over- or underrange flag turns on when the normal operating range (over/under) is exceeded. The module continues to convert the analog input up to the maximum full-scale range. The flag automatically resets when within the normal operating range.
- (2) Resolution is dependent upon your filter selection. The maximum resolution is achieved with either the 50 Hz or 60 Hz filter selected.
- (3) Rated working voltage is the maximum continuous voltage that can be applied at the input terminal, including the input signal and the value that floats above ground potential. For example, a 10V DC input signal and 20V DC potential above ground at the input terminal.
- (4) For proper operation, both the plus and minus input terminals must be within ±10V DC of analog common.
- (5) Includes offset, gain, nonlinearity, and repeatability error terms.
- (6) Repeatability is the ability of the input module to register the same reading in successive measurements for the same input signal.
- (7) Damage can occur to the input circuit if this value is exceeded.

## Response Speed – 1769-IF8, 1769-IF8K

Filter Frequency	Update Time Per Channel	Update Time Per Module
10 Hz	100 ms	400 ms
50 Hz	30 ms	120 ms
60 Hz	30 ms	120 ms
250 Hz	9 ms	36 ms
500 Hz	6 ms	24 ms

For **Environmental Specifications**, see [page 2](#).

For **Certifications**, see [page 3](#).

# 1769-IF16C

## Compact current analog input module

Simplified Input Circuit Diagram

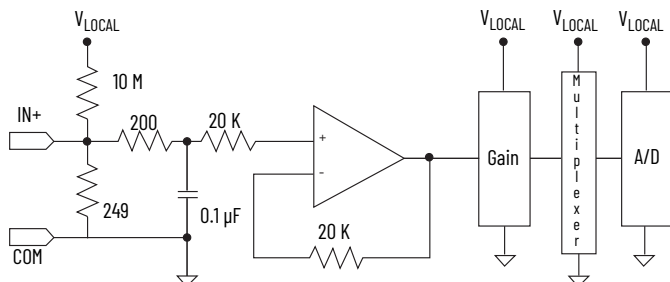

Sensor/Transmitter Input Wiring

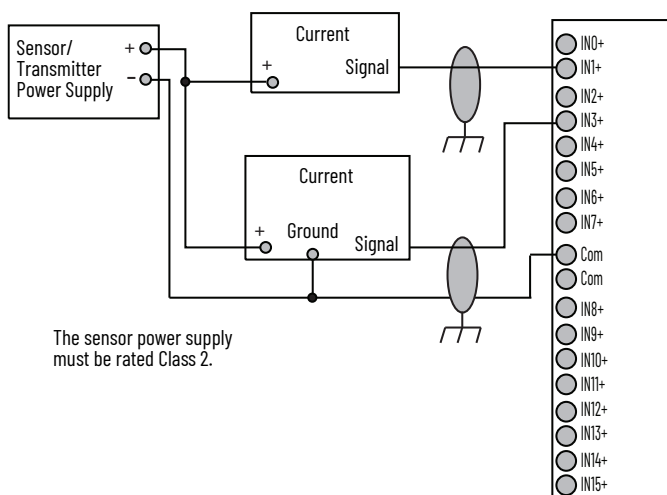

## Technical Specifications - 1769-IF16C

Attribute	1769-IF16C
Inputs	16 single-ended
Input range	0...20 mA 4...20 mA
Full-scale range <sup>(1)</sup>	0...21 mA 3.2...21 mA
Current draw @ 5.1V	190 mA
Current draw @ 24V	70 mA
Heat dissipation, max	4.0 W
Converter type	Sigma Delta
Resolution <sup>(2)</sup>	16 bits (unipolar), 15 bits plus sign (bipolar)
Rated working voltage <sup>(3)</sup>	30V AC/30V DC
Common mode voltage range <sup>(4)</sup>	±10V DC max per channel
Common mode rejection	> 60 dB @ 50 Hz and 60 Hz with the 16 Hz filter selected
Input impedance	249 Ω
Accuracy <sup>(5)</sup>	±0.5% full-scale @ 25 °C (77 °F)
Accuracy drift with temperature	±0.0045% per °C
Nonlinearity	±0.03%
Repeatability <sup>(6)</sup>	±0.03%
Module error	1.25%

## Technical Specifications - 1769-IF16C

Attribute	1769-IF16C
Overload at input terminals, max <sup>(7)</sup>	±28 mA continuous, ±7.6V DC
Isolation voltage	500V AC or 710V DC for 1 minute (qualification test), group to bus 30V AC/30V DC working voltage (IEC Class II reinforced insulation)
Weight, approx	281 g (0.62 lb)
Dimensions (HxWxD), approx	118 x 35 x 87 mm (4.65 x 1.38 x 3.43 in.) Height with mounting tabs 138 mm (5.43 in.)
Slot width	1
Module location	DIN rail or panel mount
Power supply	1769-PA2, 1769-PB2, 1769-PA4, 1769-PB4
Power supply distance rating	8 modules
Terminal screw torque	0.68 N•m (6 lb•in)
Retaining screw torque	0.46 N•m (4.1 lb•in)
Wire size	(22...14 AWG) solid (22...16 AWG) stranded
Wire type	Cu-90 °C (194 °F)
Replacement terminal block	1769-RTBN18 (1 per kit)
Replacement door label	1769-RL2 series B (2 per kit)
Replacement door	1769-RD (2 per kit)
Vendor ID code	1
Product type code	10
Product code	47
Input words	22
Output words	2
Configuration words	98
Enclosure type rating	None (open-style)

- (1) The over- or underrange flag comes on when the normal operating range (over/under) is exceeded. The module continues to convert the analog input up to the maximum full-scale range. The flag automatically resets when within the normal operating range.
- (2) Resolution is dependent upon your filter selection. The maximum resolution is achieved with either the 50 Hz or 60 Hz filter selected.
- (3) Rated working voltage is the maximum continuous voltage that can be applied at the input terminal, including the input signal and the value that floats above ground potential. For example, a 10V DC input signal and 20V DC potential above ground at the input terminal.
- (4) For proper operation, both the plus and minus input terminals must be within ±10V DC of analog common.
- (5) Includes offset, gain, nonlinearity, and repeatability error terms.
- (6) Repeatability is the ability of the input module to register the same reading in successive measurements for the same input signal.
- (7) Damage can occur to the input circuit if this value is exceeded.

## Response Speed - 1769-IF16C

Filter Frequency	Step Response	Update per Input Point	Update per Module
16 Hz	1550 ms	200 ms	1600 ms
50 Hz	500 ms	70 ms	560 ms
60 Hz	420 ms	60 ms	480 ms
315 Hz	90 ms	15 ms	120 ms
1365 Hz	35 ms	5 ms	40 ms

For Environmental Specifications, see [page 2](#).

For Certifications, see [page 3](#).

# 1769-IF16V

## Compact voltage analog input module

Simplified Input Circuit Diagram

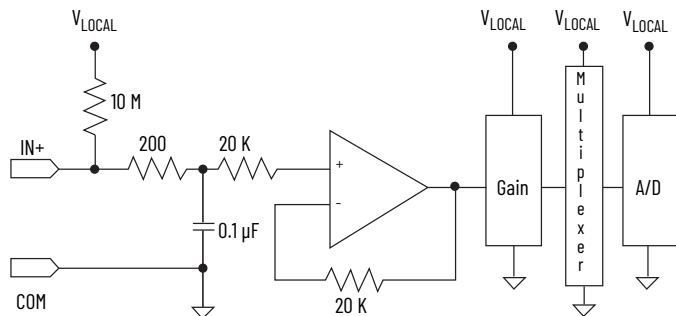

Sensor/Transmitter Input Wiring

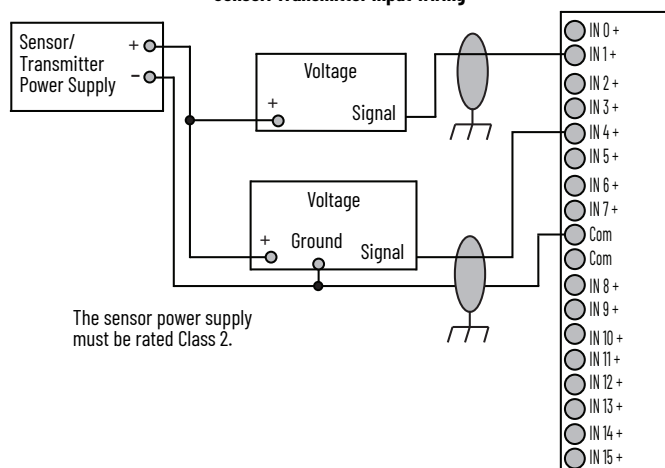

### Technical Specifications - 1769-IF16V

Attribute	1769-IF16V
Inputs	16 single-ended
Input range	±10V 0...10V 0...5V 1...5V
Full-scale range <sup>(1)</sup>	±10.5V -0.5...10.5V -0.5...5.25V 0.5...5.25V
Current draw @ 5.1V	190 mA
Current draw @ 24V	70 mA
Heat dissipation, max	2.4 W
Converter type	Sigma Delta
Resolution <sup>(2)</sup>	16 bits (unipolar), 15 bits plus sign (bipolar)
Rated working voltage <sup>(3)</sup>	30V AC/30V DC
Common mode voltage range <sup>(4)</sup>	±10V DC max per channel
Common mode rejection	> 60 dB @ 50 Hz and 60 Hz with the 16 Hz filter selected
Input impedance	> 1 MΩ
Accuracy <sup>(5)</sup>	±0.35% full-scale @ 25 °C (77 °F)
Accuracy drift with temperature	±0.03% per °C
Nonlinearity	±0.03%
Repeatability <sup>(6)</sup>	±0.06%
Module error	1.0%

### Technical Specifications - 1769-IF16V

Attribute	1769-IF16V
Overload at input terminals, max <sup>(7)</sup>	±30 mA continuous, ±7.6V DC
Isolation voltage	500V AC or 710V DC for 1 minute (qualification test), group to bus 30V AC/30V DC working voltage (IEC Class II reinforced insulation)
Weight, approx	281 g (0.62 lb)
Dimensions (HxWxD), approx	118 x 35 x 87 mm (4.65 x 1.38 x 3.43 in.) Height with mounting tabs 138 mm (5.43 in.)
Slot width	1
Module location	DIN rail or panel mount
Power supply	1769-PA2, 1769-PB2, 1769-PA4, 1769-PB4
Power supply distance rating	8 modules
Terminal screw torque	0.68 N·m (6 lb·in)
Retaining screw torque	0.46 N·m (4.1 lb·in)
Wire size	(22...14 AWG) solid (22...16 AWG) stranded
Wire type	Cu-90 °C (194 °F)
Replacement terminal block	1769-RTBN18 (1 per kit)
Replacement door label	1769-RL2 series B (2 per kit)
Replacement door	1769-RD (2 per kit)
Vendor ID code	1
Product type code	10
Product code	46
Input words	22
Output words	2
Configuration words	98
Enclosure type rating	None (open-style)

- The over- or underrange flag comes on when the normal operating range (over/under) is exceeded. The module continues to convert the analog input up to the maximum full-scale range. The flag automatically resets when within the normal operating range.
- Resolution is dependent upon your filter selection. The maximum resolution is achieved with either the 50 Hz or 60 Hz filter selected.
- Rated working voltage is the maximum continuous voltage that can be applied at the input terminal, including the input signal and the value that floats above ground potential. For example, a 10V DC input signal and 20V DC potential above ground at the input terminal.
- For proper operation, both the plus and minus input terminals must be within ±10V DC of analog common.
- Includes offset, gain, nonlinearity, and repeatability error terms.
- Repeatability is the ability of the input module to register the same reading in successive measurements for the same input signal.
- Damage can occur to the input circuit if this value is exceeded.

### Response Speed - 1769-IF16V

Filter Frequency	Step Response	Update per Input Point	Update per Module
16 Hz	1550 ms	200 ms	1600 ms
50 Hz	500 ms	70 ms	560 ms
60 Hz	420 ms	60 ms	480 ms
315 Hz	90 ms	15 ms	120 ms
1365 Hz	35 ms	5 ms	40 ms

For Environmental Specifications, see [page 2](#).

For Certifications, see [page 3](#).

# 1769-IR6

## Compact RTD/resistance input module

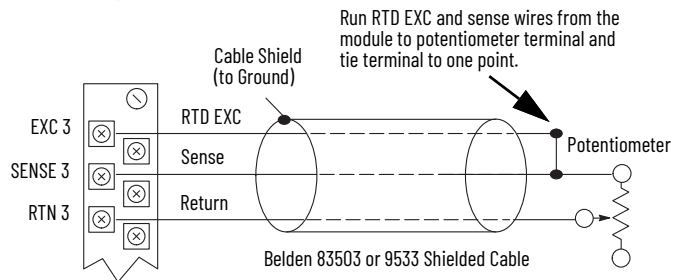
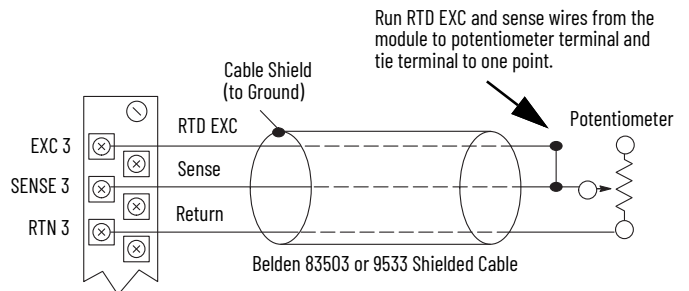
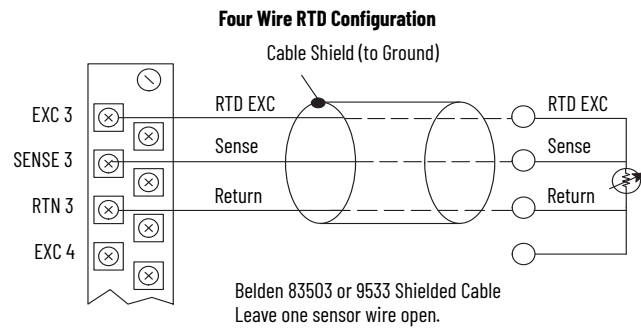
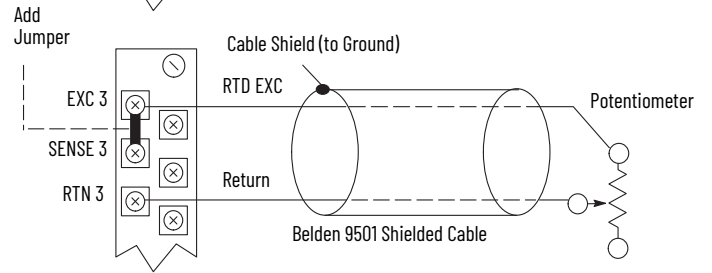
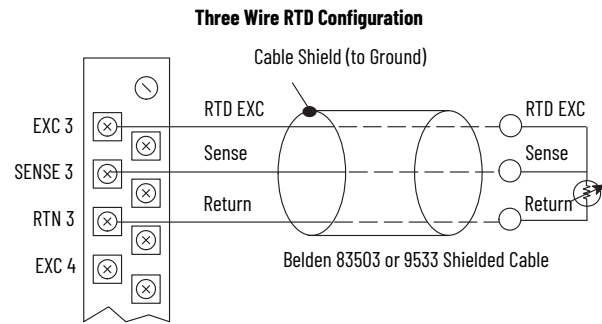
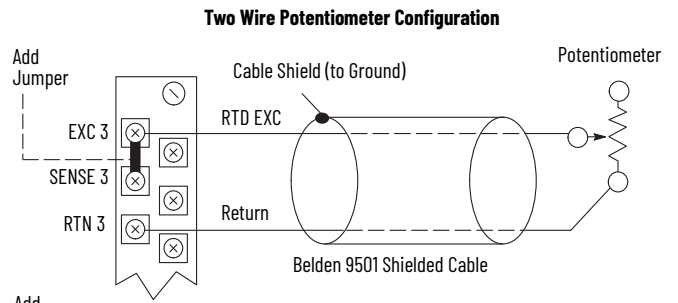
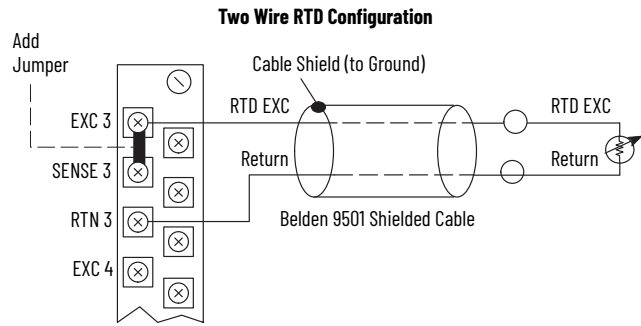

### Resistance Device Compatibility - 1769-IR6

Resistance Device Type	Resistance Range (0.5 mA Excitation)	Resistance Range (1.0 mA Excitation)
150 Ω	0...150 Ω	0...150 Ω
500 Ω	0...500 Ω	0...500 Ω
1000 Ω	0...1000 Ω	0...1000 Ω
3000 Ω	0...3000 Ω	N/A

## Data Formats for RTD Temperature Ranges for 0.5 mA and 1.0 mA Excitation Current

RTD Input Type	Engineering Units x1		Engineering Units x10		Scaled-for-PID	Proportional Counts
	0.1 °C	0.1 °F	1.0 °C	1.0 °F		
100 Ω Platinum 385	-2000...+8500	-3280...+15620	-200...+850	-328...+1562	0...16383	-32768...+32767
200 Ω Platinum 385	-2000...+8500	-3280...+15620	-200...+850	-328...+1562	0...16383	-32768...+32767
500 Ω Platinum 385	-2000...+8500	-3280...+15620	-200...+850	-328...+1562	0...16383	-32768...+32767
1000 Ω Platinum 385	-2000...+8500	-3280...+15620	-200...+850	-328...+1562	0...16383	-32768...+32767
100 Ω Platinum 3916	-2000...+6300	-3280...+11660	-200...+630	-328...+1166	0...16383	-32768...+32767
200 Ω Platinum 3916	-2000...+6300	-3280...+11660	-200...+630	328...1166	0...16383	-32768...+32767
500 Ω Platinum 3916	-2000...+6300	-3280...+11660	-200...+630	328...1166	0...16383	-32768...+32767
1000 Ω Platinum 3916	-2000...+6300	-3280...+11660	-200...+630	328...1166	0...16383	-32768...+32767
10 Ω Copper 426	-1000...+2600	-1480...+5000	100...260	-148...+500	0...16383	-32768...+32767
120 Ω Nickel 618	-1000...+2600	-1480...+5000	-100...+260	-148...+500	0...16383	-32768...+32767
120 Ω Nickel 672	-800...+2600	-1120...+5000	-80...+260	-112...+500	0...16383	-32768...+32767
604 Ω Nickel Iron 518	-1000...+2600	-3280...+1560	-100...+200	-328...+156	0...16383	-32768...+32767

## Temperature Range - 1769-IR6

RTD Type <sup>(1)</sup>		Temperature Range Using 0.5 mA Excitation	Temperature Range Using 1.0 mA Excitation
Platinum 385	100 Ω	-200...+850 °C (-328...+1562 °F)	-200...+850 °C (-328...+1562 °F)
	200 Ω	-200...+850 °C (-328...+1562 °F)	-200...+850 °C (-328...+1562 °F)
	500 Ω	-200...+850 °C (-328...+1562 °F)	-200...+850 °C (-328...+1562 °F)
	1000 Ω	-200...+850 °C (-328...+1562 °F)	N/A
Platinum 3916	100 Ω	-200C...630 °C (-328...+1166 °F)	-200...+630 °C (-328...+1166 °F)
	200 Ω	-200C...630 °C (-328...+1166 °F)	-200...+630 °C (-328...+1166 °F)
	500 Ω	-200C...630 °C (-328...+1166 °F)	-200...+630 °C (-328...+1166 °F)
	1000 Ω	-200C...630 °C (-328...+1166 °F)	N/A
Copper 426	10 Ω	N/A	-100...+260 °C (-148...+500 °F)
Nickel 618 <sup>(2)</sup>	120 Ω	-100...+260 °C (-148...+500 °F)	-100...+260 °C (-148...+500 °F)
Nickel 672	120 Ω	-80...+260 °C (-112...+500 °F)	-80...+260 °C (-112...+500 °F)
Nickel-Iron 518	604 Ω	-200...+180 °C (-328...+338 °F)	-100...+200 °C (-148...+392 °F)

(1) Digits following the RTD type represent the temperature coefficient of resistance (a) which is defined as the resistance change per Ω per °C. For instance, Platinum 385 refers to a Platinum RTD with a = 0.00385 Ω/Ω -°C, or simply 0.00385/°C.

(2) Actual value at 0 °C is 100 Ω per DIN standard.

## RTD Accuracy and Temperature Drift - 1769-IR6

RTD Type		Scaled Accuracy Max 25 °C (77 °F) with Calibration	Scaled Accuracy Max 0...60 °C (32...140 °F) with Calibration	Temperature Drift Max from 25 °C (77 °F) without Calibration
Copper 426	10 Ω	±0.6 °C (1.08 °F)	±1.1 °C (1.98 °F)	±0.032 °C/°C (0.032 °F/°F)
Nickel 618	120 Ω	±0.2 °C (±0.36 °F)	±0.4 °C (±0.72 °F)	±0.012 °C/°C (±0.012 °F/°F)
Nickel 672	120 Ω	±0.2 °C (±0.36 °F)	±0.4 °C (±0.72 °F)	±0.012 °C/°C (±0.012 °F/°F)
Nickel-Iron 518	604 Ω	±0.3 °C (±0.54 °F)	±0.5 °C (±0.9 °F)	±0.015 °C/°C (±0.015 °F/°F)
Platinum 385	100 Ω	±0.5 °C (±0.9 °F)	±0.9 °C (±1.62 °F)	±0.026 °C/°C (±0.026 °F/°F)
	200 Ω	±0.5 °C (±0.9 °F)	±0.9 °C (±1.62 °F)	±0.026 °C/°C (±0.026 °F/°F)
	500 Ω	±0.5 °C (±0.9 °F)	±0.9 °C (±1.62 °F)	±0.026 °C/°C (±0.026 °F/°F)
	1000 Ω	±0.5 °C (±0.9 °F)	±0.9 °C (±1.62 °F)	±0.026 °C/°C (±0.026 °F/°F)
Platinum 3916	100 Ω	±0.4 °C (±0.72 °F)	±0.8 °C (±1.44 °F)	±0.023 °C/°C (±0.023 °F/°F)
	200 Ω	±0.4 °C (±0.72 °F)	±0.8 °C (±1.44 °F)	±0.023 °C/°C (±0.023 °F/°F)
	500 Ω	±0.4 °C (±0.72 °F)	±0.8 °C (±1.44 °F)	±0.023 °C/°C (±0.023 °F/°F)
	1000 Ω	±0.4 °C (±0.72 °F)	±0.8 °C (±1.44 °F)	±0.023 °C/°C (±0.023 °F/°F)

RTD Standards - 1769-IR6

RTD Type	$\alpha$ <sup>(1)</sup>	IEC-751 1983, Amend. 2 1995	DIN 43760 1987	SAMA <sup>(2)</sup> Standard RC21-4- 1966	Japanese Industrial Standard JIS C1604-1989	Japanese Industrial Standard JIS C1604-1997	Minco (3)
100 $\Omega$ Pt	0.00385	X	X			X	
200 $\Omega$ Pt	0.00385	X	X			X	
500 $\Omega$ Pt	0.00385	X	X			X	
1000 $\Omega$ Pt	0.00385	X	X			X	
100 $\Omega$ Pt	0.03916				X		
200 $\Omega$ Pt	0.03916				X		
500 $\Omega$ Pt	0.03916				X		
1000 $\Omega$ Pt	0.03916				X		
10 $\Omega$ Cu <sup>(4)</sup>	0.00426			X			
120 $\Omega$ Ni <sup>(5)</sup>	0.00618		X				
120 $\Omega$ Ni	0.00372						X
604 $\Omega$ NiFe	0.00518						X

- (1)  $\alpha$  is the temperature coefficient of resistance, which is defined as the resistance change per ohm per °C.
- (2) Scientific Apparatus Makers Association
- (3) Minco Type "NA" (Nickel) and Minco Type "FA" (Nickel-Iron)
- (4) Actual value at 0 °C (32 °F) is 9.04  $\Omega$  per SAMA standard RC21-4-1966.
- (5) Actual value at 0 °C (32 °F) is 100  $\Omega$  per SAMA standard RC21-4-1966.

Technical Specifications - 1769-IR6

Attribute	1769-IR6
Inputs	6 RTD inputs
Input range	0...150 $\Omega$ 0...500 $\Omega$ 0...1000 $\Omega$ 0...3000 $\Omega$
Resolution	Input filter and configuration dependent
Sensors supported	100, 200, 500, 1000 $\Omega$ Platinum 385 100, 200, 500, 1000 $\Omega$ Platinum 3916 120 $\Omega$ Nickel 672 120 $\Omega$ Nickel 618 10 $\Omega$ Nickel-iron 518
Current draw @ 5.1V	100 mA
Current draw @ 24V	35 mA
Heat dissipation, max	1.5 W
Converter type	Sigma Delta
Common mode voltage range	$\pm$ 10V DC max
Common mode rejection	110 dB @ 50 Hz with the 10 Hz or 50 Hz filter selected 110 dB @ 60 Hz with the 10 Hz or 60 Hz filter selected
Normal mode rejection ratio	70 dB @ 50 Hz with the 10 Hz or 50 Hz filter selected 70 dB @ 60 Hz with the 10 Hz or 60 Hz filter selected
Cable impedance, max	25 $\Omega$
Input impedance	> 10 M $\Omega$
Accuracy @ 25 °C (77 °F) <sup>(1)</sup> (50/60 Hz filter)	$\pm$ 0.5 °C (0.9 °F) for Pt 385 $\pm$ 0.4 °C (0.72 °F) for Pt 3916 $\pm$ 0.3 °C (0.54 °F) for Ni $\pm$ 0.3 °C (0.54 °F) for NiFe $\pm$ 0.8 °C (1.44 °F) for Cu $\pm$ 0.15 $\Omega$ for 150 $\Omega$ range $\pm$ 0.5 $\Omega$ for 500 $\Omega$ range $\pm$ 1.0 $\Omega$ for 1000 $\Omega$ range $\pm$ 1.5 $\Omega$ for 3000 $\Omega$ range
Accuracy @ 0...60 °C (32...140 °F) <sup>(1)</sup> (50/60 Hz filter)	$\pm$ 0.9 °C (1.62 °F) for Pt 385 $\pm$ 0.8 °C (1.44 °F) for Pt 3916 $\pm$ 0.5 °C (0.9 °F) for Ni $\pm$ 0.5 °C (0.9 °F) for NiFe $\pm$ 1.1 °C (1.98 °F) for Cu $\pm$ 0.25 $\Omega$ for 150 $\Omega$ range $\pm$ 0.8 $\Omega$ for 500 $\Omega$ range $\pm$ 1.5 $\Omega$ for 1000 $\Omega$ range $\pm$ 2.5 $\Omega$ for 3000 $\Omega$ range

Technical Specifications - 1769-IR6

Attribute	1769-IR6
Accuracy drift @ 0...60 °C (32...140 °F) <sup>(1)</sup>	$\pm$ 0.026 °C/°C (0.026 °F/°F) for Pt 385 $\pm$ 0.023 °C/°C (0.023 °F/°F) for Pt 3916 $\pm$ 0.012 °C/°C (0.012 °F/°F) for Ni $\pm$ 0.015 °C/°C (0.015 °F/°F) for NiFe $\pm$ 0.032 °C/°C (0.032 °F/°F) for Cu $\pm$ 0.007 $\Omega$ /°C ( $\pm$ 0.013W/°F) for 150 $\Omega$ $\pm$ 0.023 $\Omega$ /°C ( $\pm$ 0.041W/°F) for 500 $\Omega$ $\pm$ 0.043 $\Omega$ /°C ( $\pm$ 0.077W/°F) for 1000 $\Omega$ $\pm$ 0.072 $\Omega$ /°C ( $\pm$ 0.130W/°F) for 3000 $\Omega$
Nonlinearity	$\pm$ 0.05%
Repeatability <sup>(2)</sup> (50/60 Hz filter)	$\pm$ 0.01 °C (0.018 °F) for Ni and NiFe $\pm$ 0.2 °C (0.36 °F) for other RTD inputs $\pm$ 0.04 $\Omega$ for 150 $\Omega$ resistances $\pm$ 0.2 $\Omega$ for other resistances
Open circuit detection time <sup>(3)</sup>	6 ms...303 s
Isolation voltage	720V DC for 1 minute, optical and magnetic (qualification), channel to bus 30V AC/30V DC working voltage (IEC Class II reinforced insulation)
Weight, approx	276 g (0.61 lb)
Dimensions (HxWxD), approx	118 x 35 x 87 mm (4.65 x 1.38 x 3.43 in.) Height with mounting tabs 138 mm (5.43 in.)
Slot width	1
Module location	DIN rail or panel mount
Power supply	1769-PA2, 1769-PB2, 1769-PA4, 1769-PB4
Power supply distance rating	8 modules
Terminal screw torque	0.68 N•m (6 lb•in)
Retaining screw torque	0.46 N•m (4.1 lb•in)
Recommended cable	2-wire configuration: Belden 9501 or equivalent 3-wire configuration: Belden 9533 or equivalent 4-wire configuration: Belden 83503 or equivalent
Wire size	(22...14 AWG) solid (22...16 AWG) stranded
Wire type	Cu-90 °C (194 °F)
IEC input compatibility	Type 1+
Replacement terminal block	1769-RTBN18 (1 per kit)
Replacement door label	1769-RL2 series B (2 per kit)
Replacement door	1769-RD (2 per kit)
Vendor ID code	1
Product type code	10
Product code	37
Enclosure type rating	None (open-style)

- (1) Accuracy is dependent upon the Analog/Digital converter output rate selection, excitation current selection, data format, and input noise.
- (2) Repeatability is the ability of the input module to register the same reading in successive measurements for the same input signal.
- (3) Open-circuit detection time is equal to channel update time.

For Environmental Specifications, see [page 2](#).

For Certifications, see [page 3](#).

# 1769-IT6

## Compact Thermocouple/mV input module

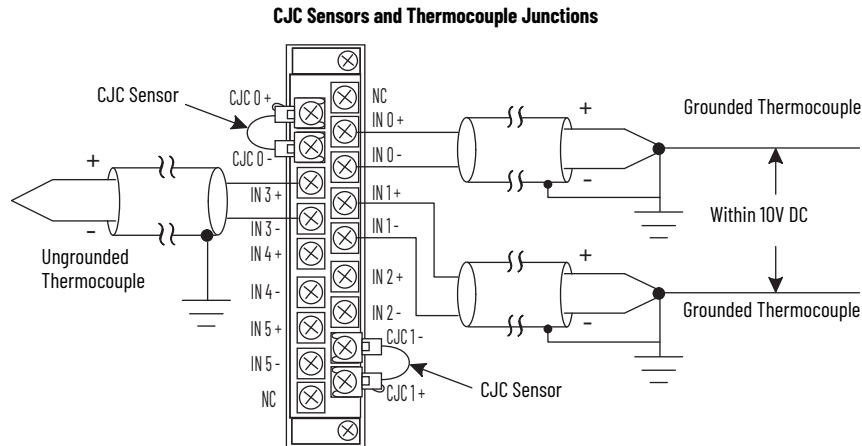

### Input Specifications - 1769-IT6

Input Type	Range	Engineering Units x1		Engineering Units x10		Scaled-for-PID	Raw/Proportional Data	Percent Range
		0.1 °C	0.1 °F	1.0 °C	1.0 °F			
Thermocouple Type J	-210...+1200 °C (-346...+2192 °F)	-2100...+12000	-3460...+21920	-210...+1200	-346...+2192	0...16383	-32767...+32767	0...10000
Thermocouple Type K	-270...+1370 °C (-454...+2498 °F)	-2700...+13700	-4540...+24980	-270...+1370	-454...+2498			
Thermocouple Type T	-270...+400 °C (-454...+752 °F)	-2700...+4000	-4540...+7520	-270...+400	-454...+752			
Thermocouple Type E	-270...+1000 °C (-454...+1832 °F)	-2700...+10000	-4540...+18320	-270...+1000	-454...+1832			
Thermocouple Type R	0...1768 °C (32...3214 °F)	0...17680	320...32140	0...1768	32...3214			
Thermocouple Type S	0...1768 °C (32...3214 °F)	0...17680	320...32140	0...1768	32...3214			
Thermocouple Type B	300...1820 °C (572...3308 °F)	3000...18200	5720...32767 <sup>(1)</sup>	300...1820	572...3308			
Thermocouple Type N	-210...+1300 °C (-346...+2372 °F)	-2100...+13000	-3460...+23720	-210...+1300	-346...+2372			
Thermocouple Type C	0...2315 °C (+32...+ 4199 °F)	0...23150	320...32767 <sup>(1)</sup>	0...2315	32...4199			
Millivolt Input Type ±50 mV	-50...+50 mV	-5000...+5000 <sup>(2)</sup>		-500...+500 <sup>(2)</sup>				
Millivolt Input Type ±100 mV	-100...+100 mV	-10000...+10000 <sup>(2)</sup>		-1000...+1000 <sup>(2)</sup>				

(1) Type B and C thermocouples cannot be represented in engineering units x1(°F) above 3276.7 °F; therefore, it is treated as an overrange error.  
 (2) When millivolts are selected, the temperature setting is ignored. Analog input date is the same for °C or °F selection.

### Input Accuracy - 1769-IT6

Input Type <sup>(1)</sup>	With Autocalibration Enabled		Without Autocalibration
	Accuracy <sup>(2)(3)</sup> for 10 Hz, 50 Hz, and 60 Hz Filters (Max)		Temperature Drift (Max) <sup>(2)(4)</sup>
	@ 25 °C (77 °F) Ambient	@ 0...60 °C (32...140 °F) Ambient	@ 0...60 °C (32...140 °F) Ambient
Thermocouple J (-210...+1200 °C [-346...+2192 °F])	±0.6 °C [±1.1 °F]	±0.9 °C [±1.7 °F]	±0.0218 °C/°C [±0.0218 °F/°F]
Thermocouple N (-200...+1300 °C [-328...+2372 °F])	±1 °C [±1.8 °F]	±1.5 °C [±2.7 °F]	±0.0367 °C/°C [±0.0367 °F/°F]
Thermocouple N (-210...-200 °C [-346...-328 °F])	±1.2 °C [±2.2 °F]	±1.8 °C [±3.3 °F]	±0.0424 °C/°C [±0.0424 °F/°F]
Thermocouple T (-230...+400 °C [-382...+752 °F])	±1 °C [±1.8 °F]	±1.5 °C [±2.7 °F]	±0.0349 °C/°C [±0.0349 °F/°F]
Thermocouple T (-270...-230 °C [-454...-382 °F])	±5.4 °C [±9.8 °F]	±7.0 °C [±12.6 °F]	±0.3500 °C/°C [±0.3500 °F/°F]
Thermocouple K (-230...+1370 °C [-382...+2498 °F])	±1 °C [±1.8 °F]	±1.5 °C [±2.7 °F]	±0.4995 °C/°C [±0.4995 °F/°F]
Thermocouple K (-270...-225 °C [-454...-373 °F])	±7.5 °C [±13.5 °F]	±10 °C [±18 °F]	±0.0378 °C/°C [±0.0378 °F/°F]
Thermocouple E (-210...+1000 °C [-346...+1832 °F])	±0.5 °C [±0.9 °F]	±0.8 °C [±1.5 °F]	±0.0199 °C/°C [±0.0199 °F/°F]
Thermocouple E (-270...-210 °C [-454...-346 °F])	±4.2 °C [±7.6 °F]	±6.3 °C [±11.4 °F]	±0.2698 °C/°C [±0.2698 °F/°F]
Thermocouple R	±1.7 °C [±3.1 °F]	±2.6 °C [±4.7 °F]	±0.0613 °C/°C [±0.0613 °F/°F]
Thermocouple S	±1.7 °C [±3.1 °F]	±2.6 °C [±4.7 °F]	±0.0600 °C/°C [±0.0600 °F/°F]
Thermocouple C	±1.8 °C [±3.3 °F]	±3.5 °C [±6.3 °F]	±0.0899 °C/°C [±0.0899 °F/°F]
Thermocouple B	±3.0 °C [±5.4 °F]	±4.5 °C [±8.1 °F]	±0.1009 °C/°C [±0.1009 °F/°F]
±50 mV	±15 µV	±25 µV	±0.44 µV/°C [±0.80 µV/°F]
±100 mV	±20 µV	±30 µV	±0.69 µV/°C [±1.25 µV/°F]

(1) The module uses the National Institute of Standards and Technology (NIST) ITS-90 standard for thermocouple linearization.  
 (2) Accuracy and temperature drift information excludes the effects of errors or drift in the cold junction compensation circuit.  
 (3) Accuracy is dependent upon the analog/digital converter output rate selection, data format, and input noise.  
 (4) Temperature drift with autocalibration is slightly better than without autocalibration.

## Repeatability at 25 °C (77 °F) - 1769-IT6

Input Type	Repeatability for 10 Hz Filter <sup>(1) (2)</sup>
Thermocouple J	±0.1 °C [±0.18 °F]
Thermocouple N (-110...+1300 °C [-166...+2372 °F])	±0.1 °C [±0.18 °F]
Thermocouple N (-210...-110 °C [-346...-166 °F])	±0.25 °C [±0.45 °F]
Thermocouple T (-170...+400 °C [-274...+752 °F])	±0.1 °C [±0.18 °F]
Thermocouple T (-270...-170 °C [-454...-274 °F])	±1.5 °C [±2.7 °F]
Thermocouple K (-270...+1370 °C [-454...+2498 °F])	±0.1 °C [±0.18 °F]
Thermocouple (-270...-170 °C [-454...-274 °F])	±2.0 °C [±3.6 °F]
Thermocouple E (-220...+1000 °C [-364...+1832 °F])	±0.1 °C [±0.18 °F]
Thermocouple E (-270...-220 °C [-454...-364 °F])	±1.0 °C [±1.8 °F]
Thermocouple S	±0.4 °C [±0.72 °F]
Thermocouple R	±0.4 °C [±0.72 °F]
Thermocouple C	±0.7 °C [±1.26 °F]
Thermocouple B	±0.2 °C [±0.36 °F]
±50 mV	±6 µV
±100 mV	±6 µV

- (1) Repeatability is the ability of the input module to register the same reading in successive measurements for the same input signal.
- (2) Repeatability at any other temperature in the 0...60 °C (32...140 °F) range is the same as long as the temperature is stable.

**IMPORTANT** To reduce the effects of electrical noise, install the 1769-IT6 module at least two slots away from the AC power supplies.

## Technical Specifications - 1769-IT6

Attribute	1769-IT6
Inputs	6 RTD inputs 2 CJC sensors
Input range	0...150 Ω 0...500 Ω 0...1000 Ω 0...3000 Ω
Resolution	Input filter and configuration dependent
Thermocouples	B, E, J, K, R, S, T, N, C
Bus current draw	5V DC, 140 mA 24V DC, 30 mA
Heat dissipation, max	1.5 W
Converter type	Sigma Delta
Response speed per channel	3...300 ms, depending on input filter and configuration
Rated working voltage <sup>(1)</sup>	30V AC/30V DC
Common mode voltage range <sup>(2)</sup>	±10V DC max
Common mode rejection	115 dB @ 50 Hz with 10 Hz or 50 Hz filter 115 dB @ 60 Hz with 10 Hz or 60 Hz filter
Normal mode rejection ratio	85 dB @ 50 Hz with the 10 Hz or 50 Hz filter selected 85 dB @ 60 Hz with the 10 Hz or 60 Hz filter selected

## Technical Specifications - 1769-IT6

Attribute	1769-IT6
Cable impedance, max	25 Ω
Input impedance	> 10 MΩ
CJC assembly accuracy	±1.0 °C (±1.8 °F)
Nonlinearity (in percent full-scale)	±0.03%
Open-circuit detection time	7 ms...2.1 s <sup>(3)</sup>
Overload at input terminals, max	±35V DC continuous <sup>(4)</sup>
Isolation voltage	720V DC for 1 min (qualification test) 30V AC/30V DC working voltage, group to bus
Weight, approx	276 g (0.61 lb)
Dimensions (HxWxD), approx	118 x 35 x 87 mm (4.65 x 1.38 x 3.43 in.) Height with mounting tabs 138 mm (5.43 in.)
Slot width	1
Module location	DIN rail or panel mount
Power supply	1769-PA2, 1769-PB2, 1769-PA4, 1769-PB4
Power supply distance rating	8 modules
Terminal screw torque	0.68 N·m (6 lb·in)
Retaining screw torque	0.46 N·m (4.1 lb·in)
Recommended cable	2-wire configuration: Belden 9501 or equivalent 3-wire configuration: Belden 9533 or equivalent 4-wire configuration: Belden 83503 or equivalent
Wire size	(22...14 AWG) solid (22...16 AWG) stranded
Wire type	Cu-90 °C (194 °F)
IEC input compatibility	Type 1+
Replacement terminal block	1769-RTB18 (1 per kit)
Replacement door label	1769-RL2 series B (2 per kit)
Replacement door	1769-RD (2 per kit)
Vendor ID code	1
Product type code	10
Product code	36
Enclosure type rating	None (open-style)

- (1) Rated working voltage is the maximum continuous voltage that can be applied at the input terminal, including the input signal and the value that floats above ground potential. For example, a 30V DC input signal and 20V DC potential above ground at the input terminal.
- (2) For proper operation, both the plus and minus input terminals must be within ±10V DC of analog common.
- (3) Open-circuit detection time is equal to the module scan time, which is based on the number of enabled channels, and the filter frequency of each channel.
- (4) Maximum current input is limited due to input impedance.

For **Environmental Specifications**, see [page 2](#).

For **Certifications**, see [page 3](#).

## 1769-OF2, 1769-OF2K

### Compact voltage/current output analog module

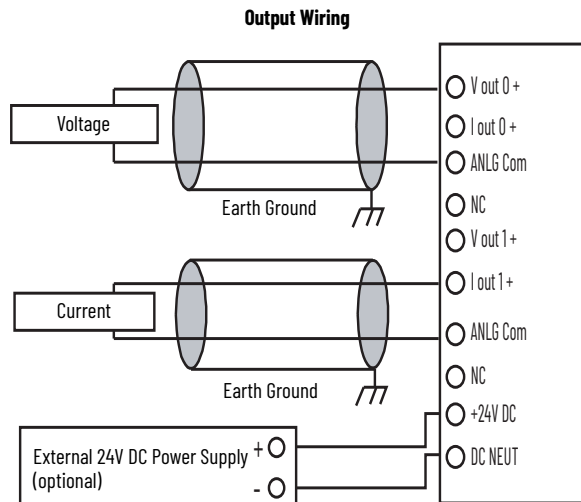

The external power supply must be rated Class 2, with a 24V DC range of 20.4...26.4V DC and 60 mA minimum. Series B and later modules support this option.

### Technical Specifications - 1769-OF2, 1769-OF2K

Attribute	1769-OF2, 1769-OF2K
Outputs	2 single-ended
Output range	±10V 0...10V 0...5V 1...5V 0...20 mA 4...20 mA
Full-scale range <sup>(1)</sup>	±10.5V -0.5...10.5V -0.5...5.25V 0.5...5.25V 0...21 mA 3.2...21 mA
Resolution	14 bits (unipolar) 14 bits plus sign (bipolar) ±10V DC: sign + 14 bits, 0.64 mV 0...10V DC: sign + 13 bits, 0.64 mV 0...5V DC: sign + 14 bits, 0.64 mV 1...5V DC: sign + 14 bits, 1.28 µA 0...20 mA: sign + 13 bits, 0.64 mV 4...20 mA: sign + 14 bits, 1.28 µA
Current draw @ 5.1V	120 mA
Current draw @ 24V	120 mA
Converter type	Delta Sigma
Heat dissipation, max	2.63 W
Conversion rate (all channels), max	2.5 ms
Step response to 63% <sup>(2)</sup>	2.9 ms
Current load on voltage output, max	10 mA
Resistive load on current output	0...500 Ω (includes wire resistance)
Load range on voltage output	> 1 kΩ @ 10V DC
Inductive load (current outputs), max	0.1 mH
Capacitive load (voltage outputs), max	1 µF
Field calibration	None required

### Technical Specifications - 1769-OF2, 1769-OF2K

Attribute	1769-OF2, 1769-OF2K
Accuracy <sup>(3)</sup>	Voltage: ±0.5% full-scale @ 25 °C (77 °F) Current: ±0.35% full-scale @ 25 °C (77 °F)
Accuracy drift with temperature	Voltage: ±0.0086% per °C Current: ±0.0058% per °C
Output ripple <sup>(4)</sup>	±0.05% @ 0...50 kHz
Nonlinearity	±0.05%
Repeatability <sup>(5)</sup>	±0.05%
Module error	Voltage: ±0.8% Current: ±0.55%
Offset error	±0.05%
Output impedance	15 Ω
Open and short-circuit protection	Yes
Short-circuit protection, max	21 mA
Output overvoltage protection	Yes
Time to detect open wire condition (current mode)	10 ms, typical 13.5 ms, max
Output response at system power-up and power down	±5V DC spike for < 5 ms
Rated working voltage <sup>(6)</sup>	30V AC/30V DC
Isolation voltage	500V AC or 710V DC for 1 min (qualification test), output group to bus 30V AC/30V DC working voltage (IEC Class II reinforced insulation)
Weight, approx	300 g (0.65 lb)
Dimensions (HxWxD), approx	118 x 35 x 87 mm (4.65 x 1.38 x 3.43 in.) Height with mounting tabs 138 mm (5.43 in.)
Slot width	1
Module location	DIN rail or panel mount
Power supply	1769-PA2, 1769-PB2, 1769-PA4, 1769-PB4
Optional 24V DC Class 2 power supply voltage range <sup>(7)</sup>	20.4...26.4V DC
Power supply distance rating	8 modules
Terminal screw torque	0.68 N•m (6 lb•in)
Retaining screw torque	0.46 N•m (4.1 lb•in)
Wire size	(22...14 AWG) solid (22...16 AWG) stranded
Wire type	Cu-90 °C (194 °F)
Replacement terminal block	1769-RTBN18 (1 per kit)
Replacement door label	1769-RL2 (2 per kit)
Replacement door	1769-RD (2 per kit)
Vendor ID code	1
Product type code	10
Product code	32
Enclosure type rating	None (open style)

- (1) The over- or underrange flag comes on when the normal operating range (over/under) is exceeded. The module continues to convert the analog input up to the maximum full-scale range. The flag automatically resets when within the normal operating range.
- (2) Step response is the time between when the D/A converter was instructed to go from minimum to full range until the device is at 63% of full range.
- (3) Includes offset, gain, nonlinearity, and repeatability error terms.
- (4) Output ripple is the amount that a fixed output varies with time, which assumes a constant load and temperature.
- (5) Repeatability is the ability of the input module to register the same reading in successive measurements for the same input signal.
- (6) Rated working voltage is the maximum continuous voltage that can be applied at the input terminal, including the input signal and the value that floats above ground potential. For example, a 10V DC input signal and 20V DC potential above ground at the input terminal.
- (7) If the optional 24V DC Class 2 power supply is used, the 24V DC current draw from the bus is 0 mA.

For Environmental Specifications, see [page 2](#).

For Certifications, see [page 3](#).

# 1769-OF4

## Compact voltage/current output analog module

Simplified Schematic

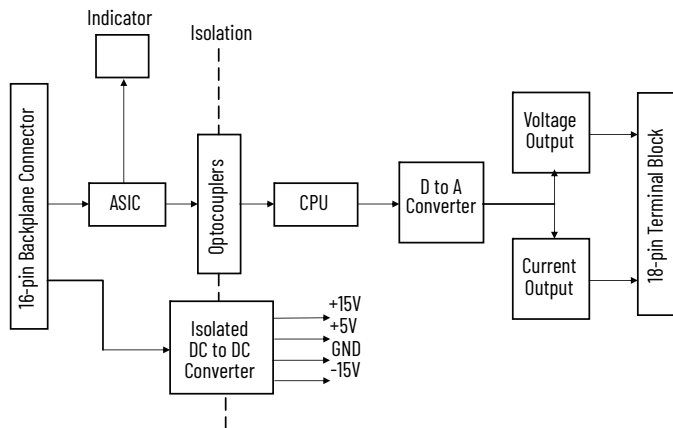

Output Wiring

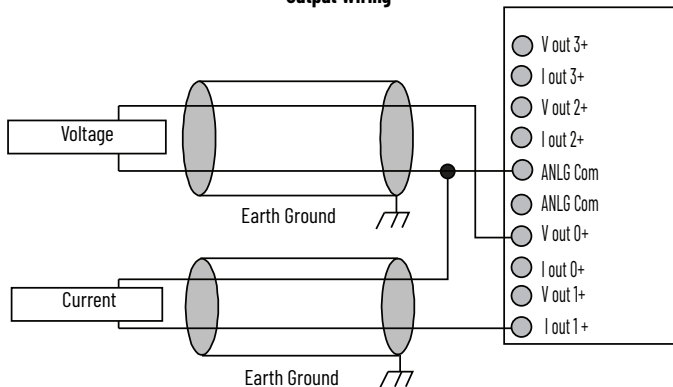

## Technical Specifications - 1769-OF4, 1769-OF4K

Attribute	1769-OF4, 1769-OF4K
Outputs	4 single-ended
Output range	±10V 0...10V 0...5V 1...5V 0...20 mA 4...20 mA
Full-scale range <sup>(1)</sup>	±10.5V -0.5...10.5V -0.5...5.25V 0.5...5.25V 0...21 mA 3.2...21 mA
Resolution	15 bits plus sign unipolar and bipolar
Current draw @ 5.1V	120 mA
Current draw @ 24V	170 mA
Heat dissipation, max	2.86 W
Conversion rate (all channels), max	Interrupts not enabled: 2.5 ms Interrupts enabled: 3.8 ms
Step response to 63% <sup>(2)</sup>	2.9 ms
Resistive load	Current: 0...600 Ω (includes wire resistance) Voltage: 1 KΩ or greater

## Technical Specifications - 1769-OF4, 1769-OF4K

Attribute	1769-OF4, 1769-OF4K
Inductive load, max	0.1 mH (current load) 1.0 μF (voltage load)
Field calibration	None required
Accuracy <sup>(3)</sup>	0.5% full-scale at 25 °C (77 °F)
Accuracy drift with temperature	±0.0086% of full-scale per °C
Output ripple <sup>(4)</sup>	±0.05% @ 0...50 kHz
Nonlinearity	±0.05%
Repeatability <sup>(5)</sup>	±0.05%
Module error 0...60 °C (32...140 °F)	+/-0.8% of full-scale
Output impedance	Voltage output: < 1 Ω Current output: > 1 MΩ
Open and short-circuit protection	Yes
Short-circuit protection, max	40 mA
Output overvoltage protection	Yes
Output response at system power-up and power down	2.5...-1.0V DC spike for < 15 ms
Rated working voltage <sup>(6)</sup>	30V AC/30V DC
Isolation voltage	510V AC or 720V DC for 1 minute (qualification test), output group to bus 30V AC/30V DC working voltage (IEC Class II reinforced insulation)
Weight, approx	280 g (0.61 lb)
Dimensions (HxWxD), approx	118 x 35 x 87 mm (4.65 x 1.38 x 3.43 in.) Height with mounting tabs 138 mm (5.43 in.)
Slot width	1
Module location	DIN rail or panel mount
Power supply	1769-PA2, 1769-PB2, 1769-PA4, 1769-PB4
Power supply distance rating	8 modules
Terminal screw torque	0.68 N•m (6 lb•in)
Retaining screw torque	0.46 N•m (4.1 lb•in)
Wire size	(22...14 AWG) solid (22...16 AWG) stranded
Wire type	Cu-90 °C (194 °F)
Replacement terminal block	1769-RTBN18 (1 per kit)
Replacement door label	1769-RL2 (2 per kit)
Replacement door	1769-RD (2 per kit)
Vendor ID code	1
Product type code	10
Product code	48
Input words	5
Output words	5
Configuration words	32
Enclosure type rating	None (open style)

- (1) The over- or underrange flag comes on when the normal operating range (over/under) is exceeded. The module continues to convert the analog input up to the maximum full-scale range. The flag automatically resets when within the normal operating range.
- (2) Step response is the time between when the D/A converter was instructed to go from minimum to full range until the device is at 63% of full range.
- (3) Includes offset, gain, drift, nonlinearity, and repeatability error terms.
- (4) Output ripple is the amount that a fixed output varies with time, which assumes a constant load and temperature.
- (5) Repeatability is the ability of the output module to reproduce output readings when the same controller value is applied to it consecutively, under the same conditions and in the same direction.
- (6) Rated working voltage is the maximum continuous voltage that can be applied at the input terminal, including the input signal and the value that floats above ground potential. For example, a 10V DC input signal and 20V DC potential above ground at the input terminal.

For Environmental Specifications, see [page 2](#).

For Certifications, see [page 3](#).

# 1769-OF4CI

## Compact current output, individually isolated analog module

Output Wiring

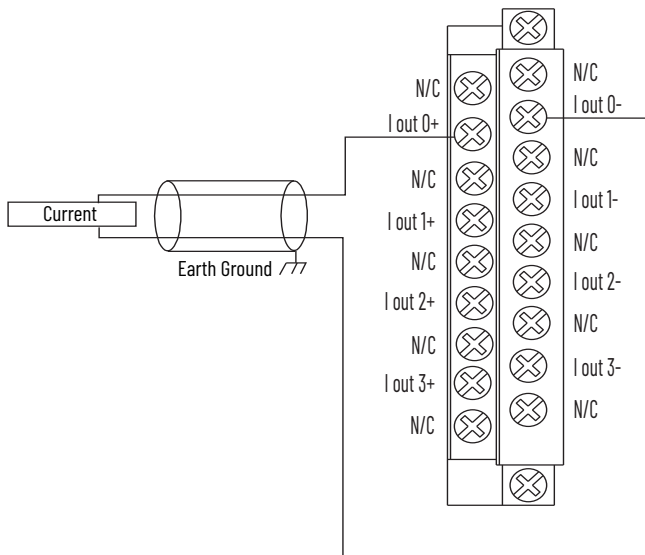

## Technical Specifications - 1769-OF4CI

Attribute	1769-OF4CI
Outputs	4 differential, individually isolated
Output range	0...20 mA 4...20 mA
Full-scale range <sup>(1)</sup>	0...21 mA 3.2...21 mA
Resolution	16 bits (unipolar) 0...20 mA: 15.91 bits, 0.323 $\mu$ A/bit 4...20 mA: 15.59 bits, 0.323 $\mu$ A/bit
Bus current draw	5V DC, 145 mA 24V DC, 120 mA
Heat dissipation, max	2.68 W
Conversion rate (all channels), max	110 ms
Limited voltage/current <sup>(2)</sup>	< 2.9 ms
Resistive load on current output	0...500 $\Omega$ (includes wire resistance)
Inductive load (current outputs), max	0.1 mH
Field calibration	None required
Accuracy <sup>(3)</sup>	$\pm 0.35\%$ full-scale @ 25 $^{\circ}$ C (77 $^{\circ}$ F)
Accuracy drift with temperature	$\pm 0.0058\%$ FS per $^{\circ}$ C
Output ripple <sup>(4)</sup>	$\pm 0.05\%$ @ 0...50 kHz
Nonlinearity	$\pm 0.05\%$
Repeatability <sup>(5)</sup>	$\pm 0.05\%$
Module error	$\pm 0.55\%$
Output impedance	>1 M $\Omega$
Open and short-circuit protection	Yes
Short-circuit protection, max	21 mA

## Technical Specifications - 1769-OF4CI

Attribute	1769-OF4CI
Output overvoltage protection	Yes
Output response at system power-up and power down	No current glitch
Rated working voltage <sup>(6)</sup>	30V AC/30V DC
Isolation voltage	500V AC or 710V DC for 1 min (qualification test), output group to bus 30V AC/30V DC working voltage (IEC Class II reinforced insulation)
Weight, approx	270 g (0.60 lb)
Dimensions (HxWxD), approx	118 x 35 x 87 mm (4.65 x 1.38 x 3.43 in.) Height with mounting tabs 138 mm (5.43 in.)
Slot width	1
Module location	DIN rail or panel mount
Power supply	1769-PA2, 1769-PB2, 1769-PA4, 1769-PB4
Power supply distance rating	8 modules
Terminal screw torque	0.68 N•m (6 lb•in)
Retaining screw torque	0.46 N•m (4.1 lb•in)
Wire size	(22...14 AWG) solid (22...16 AWG) stranded
Wire type	Cu-90 $^{\circ}$ C (194 $^{\circ}$ F)
Recommended cable	Belden 8761 (shielded)
Replacement terminal block	1769-RTBN18 (1 per kit)
Replacement door label	1769-RL2 (2 per kit)
Replacement door	1769-RD (2 per kit)
Vendor ID code	1
Product type code	10
Product code	45
Input words	6
Output words	5
Configuration words	32
Enclosure type rating	None (open style)

- (1) The over- or underrange flag comes on when the normal operating range (over/under) is exceeded. The module continues to convert the analog input up to the maximum full-scale range. The flag automatically resets when within the normal operating range.
- (2) Step response is the time between when the D/A converter was instructed to go from minimum to full range until the device is at 63% of full range.
- (3) Includes offset, gain, nonlinearity, and repeatability error terms.
- (4) Output ripple is the amount that a fixed output varies with time, which assumes a constant load and temperature.
- (5) Repeatability is the ability of the input module to register the same reading in successive measurements for the same input signal.
- (6) Rated working voltage is the maximum continuous voltage that can be applied at the input terminal, including the input signal and the value that floats above ground potential. For example, a 10V DC input signal and 20V DC potential above ground at the input terminal.

For **Environmental Specifications**, see [page 2](#).

For **Certifications**, see [page 3](#).

# 1769-OF4VI

## Compact voltage output, individually isolated analog module

Output Wiring

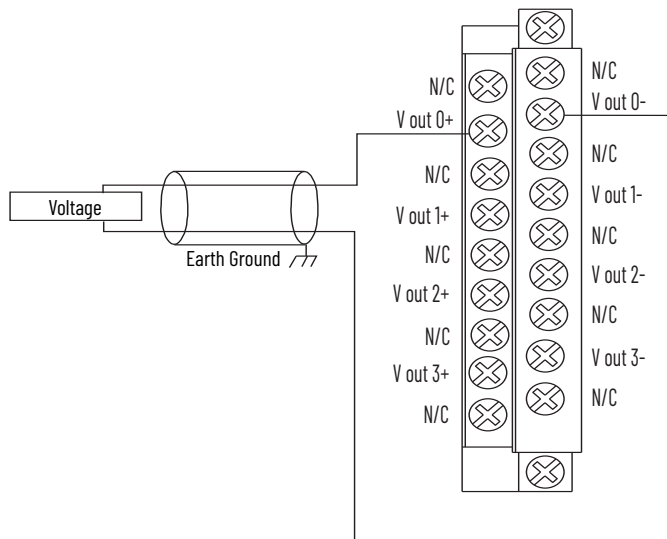

### Technical Specifications - 1769-OF4VI

Attribute	1769-OF4VI
Outputs	4 differential, individually isolated
Output range <sup>(1)</sup>	±10V DC 0...10V DC 0...5V DC 1...5V DC
Full-scale range	±10.5V DC -0.5...10.5V DC -0.5...5.25V DC 0.5...5.25V DC
Resolution	15 bits plus sign (bipolar) ±10V DC: 15.89 bits, 330 µV/bit 0...10V DC: 14.89 bits, 330 µV/bit 0...5V DC: 13.89 bits, 330 µV/bit 1...5V DC: 13.57 bits, 330 µV/bit
Bus current draw	5V DC, 145 mA 24V DC, 120 mA
Heat dissipation, max	2.0 W (all points-10 V into 2 k - worst case calculated)
Conversion rate (all channels), max	120 ms
Limited voltage/current <sup>(2)</sup>	< 2.9 ms
Load output current, max	5 mA
Load range output	>= 2 kΩ
Capacitive load (voltage outputs), max	1 µF
Field calibration	None required
Accuracy <sup>(3)</sup>	±0.5% full-scale @ 25 °C (77 °F)
Accuracy drift with temperature	±0.0086% FS per °C
Output ripple <sup>(4)</sup>	±0.05% @ 0...50 kHz
Nonlinearity	±0.05%
Repeatability <sup>(5)</sup>	±0.05%
Module error	±0.8%

### Technical Specifications - 1769-OF4VI

Attribute	1769-OF4VI
Output impedance	< 1 Ω
Open and short-circuit protection	Yes
Short-circuit protection, max	35 mA typical 42 mA, max
Output overvoltage protection	Yes
Output response at system power-up and power down	Power-up: ±1.2V DC spike for < 0.4 ms Power down: ±1.2V DC spike for 21 ms
Rated working voltage <sup>(6)</sup>	30V AC/30V DC
Isolation voltage	500V AC or 710V DC for 1 min (qualification test), output group to bus 30V AC/30V DC working voltage (IEC Class II reinforced insulation)
Weight, approx	270 g (0.60 lbs)
Dimensions (HxWxD), approx	118 x 35 x 87 mm (4.65 x 1.38 x 3.43 in.) Height with mounting tabs 138 mm (5.43 in.)
Slot width	1
Module location	DIN rail or panel mount
Power supply	1769-PA2, 1769-PB2, 1769-PA4, 1769-PB4
Power supply distance rating	8 modules
Terminal screw torque	0.68 N•m (6 lb•in)
Retaining screw torque	0.46 N•m (4.1 lb•in)
Wire size	(22...14 AWG) solid (22...16 AWG) stranded
Wire type	Cu-90 °C (194 °F)
Recommended cable	Belden 8761 (shielded)
Replacement terminal block	1769-RTBN18 (1 per kit)
Replacement door label	1769-RL2 (2 per kit)
Replacement door	1769-RD (2 per kit)
Vendor ID code	1
Product type code	10
Product code	42
Input words	6
Output words	5
Configuration words	32
Enclosure type rating	None (open style)

- (1) The over- or underrange flag comes on when the normal operating range (over/under) is exceeded. The module continues to convert the analog input up to the maximum full-scale range. The flag automatically resets when within the normal operating range.
- (2) Step response is the time between when the D/A converter was instructed to go from minimum to full range until the device is at 63% of full range.
- (3) Includes offset, gain, nonlinearity, and repeatability error terms.
- (4) Output ripple is the amount that a fixed output varies with time, which assumes a constant load and temperature.
- (5) Repeatability is the ability of the input module to register the same reading in successive measurements for the same input signal.
- (6) Rated working voltage is the maximum continuous voltage that can be applied at the input terminal, including the input signal and the value that floats above ground potential. For example, a 10V DC input signal and 20V DC potential above ground at the input terminal.

For Environmental Specifications, see [page 2](#).

For Certifications, see [page 3](#).

## 1769-OF8C

## Compact current output analog module

Output Wiring

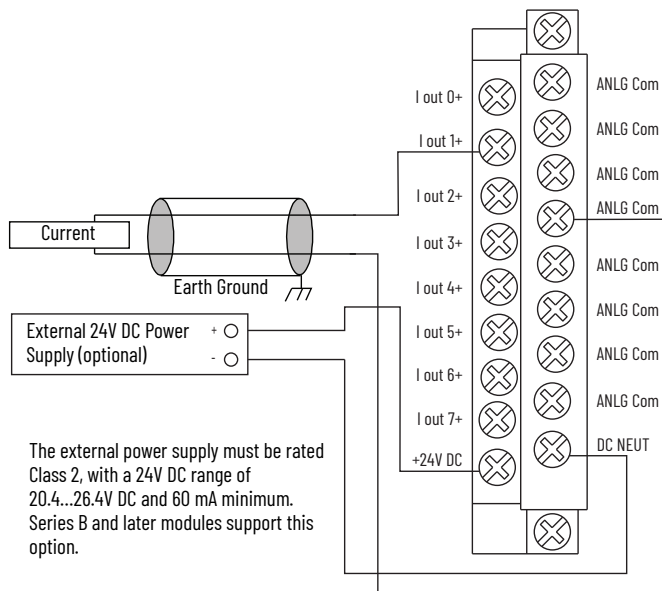

## Technical Specifications - 1769-OF8C

Attribute	1769-OF8C
Outputs	8 single-ended
Output range	0...20 mA 4...20 mA
Full-scale range <sup>(1)</sup>	0...21 mA 3.2...21 mA
Resolution	16 bits (unipolar) 0...20 mA: 15.91 bits, 0.323 $\mu$ A/bit 4...20 mA: 15.59 bits, 0.323 $\mu$ A/bit
Bus current draw	5V DC, 145 mA 24V DC, 185 mA
Heat dissipation, max	2.69 W
Conversion rate (all channels), max	5 ms
Step response to 63% <sup>(2)</sup>	< 2.9 ms
Resistive load on current output	0...500 $\Omega$ (includes wire resistance)
Inductive load (current outputs), max	0.1 mH
Field calibration	None required
Accuracy <sup>(3)</sup>	$\pm$ 0.35% full-scale @ 25 °C (77 °F)
Accuracy drift with temperature	$\pm$ 0.0058% per °C
Output ripple <sup>(4)</sup>	$\pm$ 0.05% @ 0...50 kHz
Nonlinearity	$\pm$ 0.05%
Repeatability <sup>(5)</sup>	$\pm$ 0.05%
Module error	$\pm$ 0.55%
Offset error	$\pm$ 0.05%
Output impedance	> 1 M $\Omega$

## Technical Specifications - 1769-OF8C

Attribute	1769-OF8C
Open and short-circuit protection	Yes
Short-circuit protection, max	21 mA
Output overvoltage protection	Yes
Output response at system power-up and power down	$\pm$ 0.5V DC spike for < 5 ms
Rated working voltage <sup>(6)</sup>	30V AC/30V DC
Isolation voltage	500V AC or 710V DC for 1 min (qualification test), output group to bus 30V AC/30V DC working voltage (IEC Class II reinforced insulation)
Weight, approx	281 g (0.62 lb)
Dimensions (HxWxD), approx	118 x 35 x 87 mm (4.65 x 1.38 x 3.43 in.) Height with mounting tabs 138 mm (5.43 in.)
Slot width	1
Module location	DIN rail or panel mount
Power supply	1769-PA2, 1769-PB2, 1769-PA4, 1769-PB4
Optional 24V DC Class 2 power supply voltage range <sup>(7)</sup>	20.4...26.4V DC
Power supply distance rating	8 modules
Terminal screw torque	0.68 N•m (6 lb•in)
Retaining screw torque	0.46 N•m (4.1 lb•in)
Wire size	(22...14 AWG) solid (22...16 AWG) stranded
Wire type	Cu-90 °C (194 °F)
Replacement terminal block	1769-RTBN18 (1 per kit)
Replacement door label	1769-RL2 (2 per kit)
Replacement door	1769-RD (2 per kit)
Vendor ID code	1
Product type code	10
Product code	40
Input words	11
Output words	9
Configuration words	64
Enclosure type rating	None (open style)

- (1) The over- or underrange flag comes on when the normal operating range (over/under) is exceeded. The module continues to convert the analog input up to the maximum full-scale range. The flag automatically resets when within the normal operating range.
- (2) Step response is the time between when the D/A converter was instructed to go from minimum to full range until the device is at 63% of full range.
- (3) Includes offset, gain, nonlinearity, and repeatability error terms.
- (4) Output ripple is the amount that a fixed output varies with time, which assumes a constant load and temperature.
- (5) Repeatability is the ability of the input module to register the same reading in successive measurements for the same input signal.
- (6) Rated working voltage is the maximum continuous voltage that can be applied at the input terminal, including the input signal and the value that floats above ground potential. For example, a 10V DC input signal and 20V DC potential above ground at the input terminal.
- (7) If the optional 24V DC Class 2 power supply is used, the 24V DC current draw from the bus is 0 mA.

For **Environmental Specifications**, see [page 2](#).

For **Certifications**, see [page 3](#).

# 1769-OF8V

## Compact voltage output analog module

Output Wiring

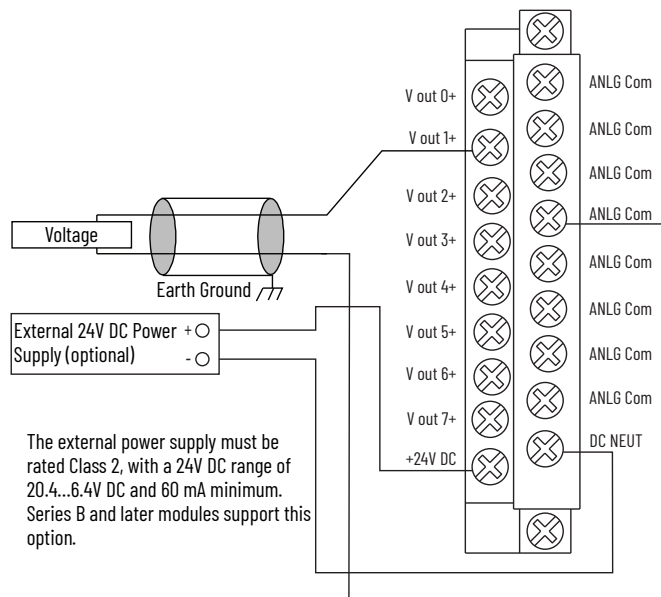

The external power supply must be rated Class 2, with a 24V DC range of 20.4...6.4V DC and 60 mA minimum. Series B and later modules support this option.

### Technical Specifications - 1769-OF8V

Attribute	1769-OF8V
Outputs	8 single-ended
Output range	±10V 0...10V 0...5V 1...5V
Full-scale range <sup>(1)</sup>	±10.5V -0.5...10.5V -0.5...5.25V 0.5...5.25V
Resolution	16 bits plus sign (bipolar) ±10V DC: 15.89 bits, 330 µV/bit 0...10V DC: 14.89 bits, 330 µV/bit 0...5V DC: 13.89 bits, 330 µV/bit 1...5V DC: 13.57 bits, 330 µV/bit
Bus current draw	5V DC, 145 mA 24V DC, 135 mA
Heat dissipation, max	2.16 W
Conversion rate (all channels), max	5.0 ms
Step response to 63% <sup>(2)</sup>	< 2.9 ms
Load output current, max	10 mA
Load range output	> 1 kΩ
Capacitive load (voltage outputs), max	1 µF
Field calibration	None required
Accuracy <sup>(3)</sup>	±0.5% full-scale @ 25 °C (77 °F)
Accuracy drift with temperature	±0.0086% per °C
Output ripple <sup>(4)</sup>	±0.05% @ 0...50 kHz
Nonlinearity	±0.05%
Repeatability <sup>(5)</sup>	±0.05%
Module error	±0.8%
Offset error	±0.05%

### Technical Specifications - 1769-OF8V

Attribute	1769-OF8V
Output impedance	< 1 Ω
Open and short-circuit protection	Yes
Short-circuit protection, max	30 mA
Output overvoltage protection	Yes
Output response at system power-up and power down	± 0.5V DC spike for < 5 ms
Rated working voltage <sup>(6)</sup>	30V AC/30V DC
Isolation voltage	500V AC or 710V DC for 1 min (qualification test), output group to bus 30V AC/30V DC working voltage (IEC Class II reinforced insulation)
Weight, approx	263 g (0.58 lb)
Dimensions (HxWxD), approx	118 x 35 x 87 mm (4.65 x 1.38 x 3.43 in.) Height with mounting tabs 138 mm (5.43 in.)
Slot width	1
Module location	DIN rail or panel mount
Power supply	1769-PA2, 1769-PB2, 1769-PA4, 1769-PB4
Optional 24V DC Class 2 power supply voltage range <sup>(7)</sup>	20.4...26.4V DC
Power supply distance rating	8 modules
Terminal screw torque	0.68 N•m (6 lb•in)
Retaining screw torque	0.46 N•m (4.1 lb•in)
Wire size	(22...14 AWG) solid (22...16 AWG) stranded
Wire type	Cu-90 °C (194 °F)
Replacement terminal block	1769-RTBN18 (1 per kit)
Replacement door label	1769-RL2 (2 per kit)
Replacement door	1769-RD (2 per kit)
Vendor ID code	1
Product type code	10
Product code	39
Input words	11
Output words	9
Configuration words	64
Enclosure type rating	None (open style)

- (1) The over- or underrange flag comes on when the normal operating range (over/under) is exceeded. The module continues to convert the analog input up to the maximum full-scale range. The flag automatically resets when within the normal operating range.
- (2) Step response is the time between when the D/A converter was instructed to go from minimum to full range until the device is at 63% of full range.
- (3) Includes offset, gain, nonlinearity, and repeatability error terms.
- (4) Output ripple is the amount that a fixed output varies with time, which assumes a constant load and temperature.
- (5) Repeatability is the ability of the input module to register the same reading in successive measurements for the same input signal.
- (6) Rated working voltage is the maximum continuous voltage that can be applied at the input terminal, including the input signal and the value that floats above ground potential. For example, a 10V DC input signal and 20V DC potential above ground at the input terminal.
- (7) If the optional 24V DC Class 2 power supply is used, the 24V DC current draw from the bus is 0 mA.

For Environmental Specifications, see [page 2](#).

For Certifications, see [page 3](#).

## Specialty I/O Modules

These specialty modules are available.

Cat. No.	Description	Page
1769-ARM	Compact address reserve module	53
1769-ASCII	Compact ASCII module	54
1769-BOOLEAN	Compact combination 24V DC sink input/source output Boolean control module	55
1769-HSC	Compact high-speed counter module	57
1769-SM2	Compact I/O to DSI module	60

### 1769-ARM

#### Compact address reserve module

Use a 1769-ARM module to reserve module slots. To use the 1769-ARM module, first create an I/O configuration and user program. Then you can remove and replace any module in the system with a 1769-ARM module after you inhibit the removed module in the programming software. If you inhibit a module, it creates an I/O configuration and user program that removes all references to that module.

To use the 1769-ARM module in MicroLogix systems, configure a generic module by using RSLogix 5000<sup>®</sup> programming software. Any user-program references to the slot position that is occupied by the 1769-ARM module must not use the parameters of another module.

#### Technical Specifications - 1769-ARM

Attribute	1769-ARM
Current draw @ 5.1V	60 mA
Current draw @ 24V	0 mA
Heat dissipation, max	0.3 W
Weight, approx	280 g (0.62 lb)
Dimensions (HxWxD), approx	118 x 35 x 87 mm (4.65 x 1.38 x 3.43 in.) Height with mounting tabs 138 mm (5.43 in.)
Slot width	1
Module location	DIN rail or panel mount
Power supply	1769-PA2, 1769-PB2, 1769-PA4, 1769-PB4
Power supply distance rating	8 modules
Vendor ID code	1
Product type code	7
Product code	74
Enclosure type rating	None (open style)

For **Environmental Specifications**, see [page 2](#).

For **Certifications**, see [page 3](#).

# 1769-ASCII

## Compact ASCII module

The 1769-ASCII module, a general-purpose two-channel ASCII interface, provides a flexible network interface to a wide variety of RS-232, RS-485, and RS-422 ASCII devices. The module provides the communication connections to the ASCII device.

**RS-232 Wiring - Module to DTE Device**  
(hardware handshaking disabled)

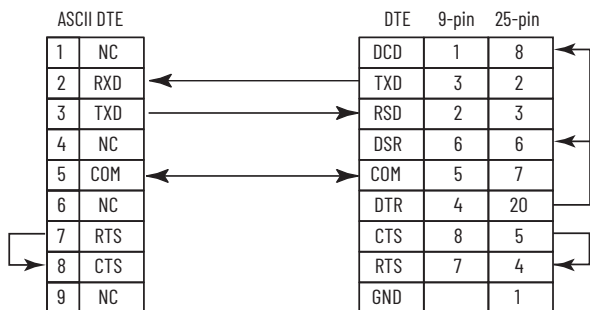

**RS-232 Wiring - Module to Printer**  
(hardware handshaking enabled, standard printer adapter cable)

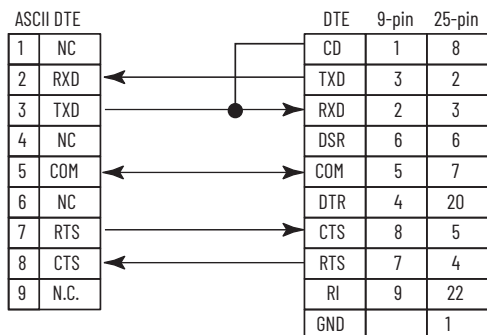

**RS-422 Wiring**

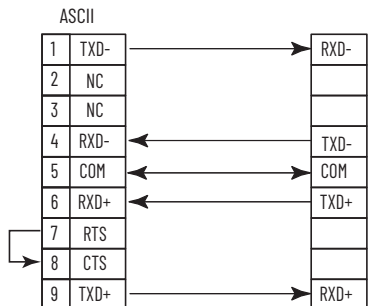

**RS-485 Wiring**

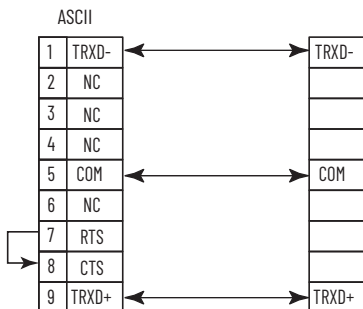

## Technical Specifications - 1769-ASCII

Attribute	1769-ASCII
Inputs	2 full-duplex (RS-232, RS-422) 2 half-duplex (RS-485)
Serial input voltage signal	3...25V DC with respect to signal ground (SG) 0, Asserted, ON, Space, Active -3...-25V DC with respect to signal ground (SG) 1, Dis-asserted, OFF, Mark, Inactive
Current draw @ 5.1V	425 mA
Current draw @ 24V	0 mA
Power dissipation, max	2.13 W
Thermal dissipation, max	7.3 BTU/hr
Isolation voltage	30V Tested to withstand 710V DC for 60 s
Transmit transaction ID	0...255
Handshaking	RTS/CTS hardware handshaking always enabled
Weight, approx	0.18 kg (0.40 lb)
Dimensions (HxWxD), approx	118 x 35 x 87 mm (4.65 x 1.38 x 3.43 in.) Height with mounting tabs 138 mm (5.43 in.)
Slot width	1
Module location	DIN rail or panel mount
Power supply	1769-PA2, 1769-PB2, 1769-PA4, 1769-PB4
Power supply distance rating	4 modules
Recommended cable	Belden 8761, shielded
Serial port connectors	Two DB-9 male with pins
Wire category	2 - on communication ports <sup>(1)</sup>
Vendor ID code	1
Product type code	109
Product code	66
Input words	108
Output words	108
Configuration words	31
Enclosure type rating	None (open style)

(1) Use this conductor category to plan conductor routing as described in the system level installation manual. See the Industrial Automation Wiring and Grounding Guidelines, publication [1770-4.1](#).

For **Environmental Specifications**, see [page 2](#).

For **Certifications**, see [page 3](#).

## 1769-BOOLEAN

## Compact combination 24V DC sink input/source output Boolean control module

Simplified Input Schematic

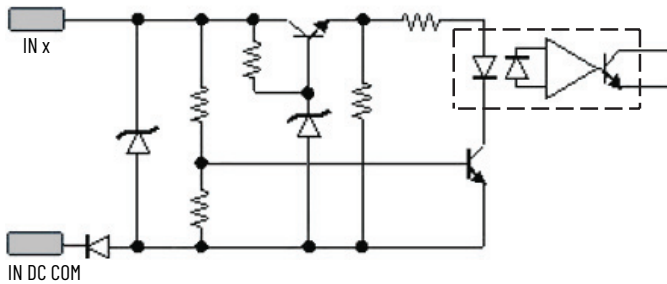

Simplified Output Schematic

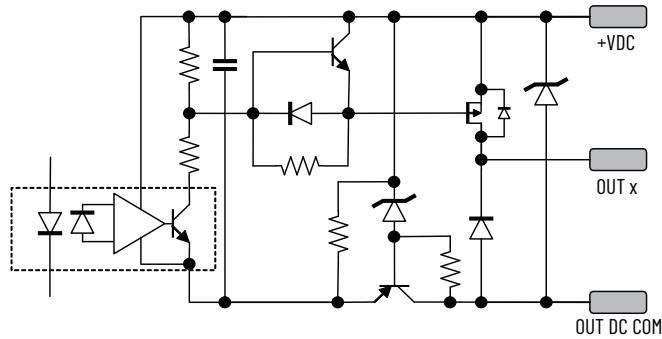

Input/output Wiring

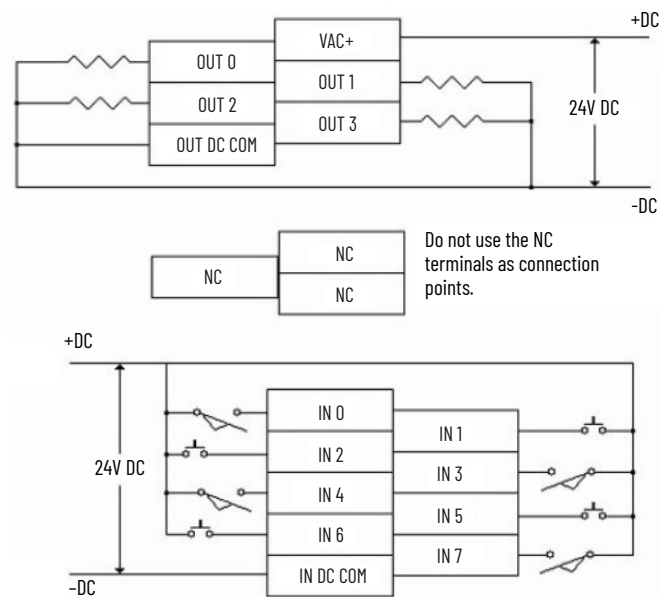

## Technical Specifications - 1769-BOOLEAN

Attribute	1769-BOOLEAN
Current draw @ 5.1V	220 mA
Current draw @ 24V	0 mA
Heat dissipation, max	3.55 W
Closed loop time	Output on-state current $\geq 5$ mA: 100 $\mu$ s max Output on-state current $< 5$ mA: 150 $\mu$ s max
Isolation voltage	Verified by one of these dielectric tests: 1200V AC for 1 s or 1697V DC for 1 s 75V DC working voltage (IEC Class II reinforced insulation)
Weight, approx	282 g (0.625 lb)
Dimensions (HxWxD), Approx	118 x 35 x 87 mm (4.65 x 1.38 x 3.43 in.) Height with mounting tabs 138 mm (5.43 in.)
Slot width	1
Module location	DIN rail or panel mount
Power supply	1769-PA2, 1769-PB2, 1769-PA4, 1769-PB4
Power supply distance rating	8 modules
Terminal screw torque	0.68 N•m (6 lb•in)
Retaining screw torque	0.46 N•m (4.1 lb•in)
Wire size	(22...14 AWG) solid (22...16 AWG) stranded
Wire type	Cu-90 °C (194 °F)
Vendor ID code	1
Product type code	109
Product code	37
Enclosure type rating	None (open-style)

## 1769-BOOLEAN Input Specifications

Attribute	1769-BOOLEAN
Inputs	8 real 8 virtual
Voltage category	24V DC sinking
Operating voltage range	10...30V DC @ 30 °C (86 °F) 10...26V DC @ 60 °C (140 °F)
Digital filter, off to on	0 s, 100 $\mu$ s, 200 $\mu$ s, 500 $\mu$ s, 1 ms, 2 ms, 4 ms, 8 ms
Digital filter, on to off	0 s, 100 $\mu$ s, 200 $\mu$ s, 500 $\mu$ s, 1 ms, 2 ms, 4 ms, 8 ms
Input delay, off to on	10 $\mu$ s
Input delay, on to off	10 $\mu$ s
Current draw @ 5.1V	115 mA
Off-state voltage, max	5V DC
Off-state current, max	1.5 mA
On-state voltage, min	10V DC
On-state current, min	2 mA
Inrush current, max <sup>(1)</sup>	250 mA
Input impedance, max	2.0 k $\Omega$ @ 24V DC 2.3 k $\Omega$ @ 30V DC
IEC input compatibility	Type 1+
Isolation voltage	Verified by one of these dielectric tests: 1200V AC for 1 s or 1697V DC for 1 s, input point to bus 75V DC working voltage (IEC Class II reinforced insulation)

- (1) A current limiting resistor can be used to limit inrush current; however, the operating characteristics of the AC input circuit are affected. If a 6.8 k $\Omega$  (2.5 W minimum) resistor is placed in series with the input, the inrush current is reduced to 35 mA. In this configuration, the minimum on-state voltage increases to 92V AC. Before adding the resistor in a hazardous environment, be sure to consider the operating temperature of the resistor and the temperature limits of the environment. The operating temperature of the resistor must remain below the temperature limit of the environment.

### 1769-BOOLEAN Output Specifications

Attribute	1769-BOOLEAN
Outputs	4
Voltage category	24V DC, sourcing
Operating voltage range	20.4...26.4V DC
Output delay, on <sup>(1)</sup>	10 $\mu$ s, output on-state current $\geq$ 5 mA
Output delay, off <sup>(1)</sup>	10 $\mu$ s, output on-state current $\geq$ 5 mA
Off-state leakage current, max <sup>(2)</sup>	1.0 mA @ 26.4V DC
On-state current, max	1.0 mA
On-state voltage drop, max	1.0V DC @ 1 A
Current per point, max	0.5 A @ 60 °C (140 °F) 1.0 A @ 30 °C (86 °F)
Surge current <sup>(3)</sup>	2 A for 10 ms, repeatable every 2 s
Isolation voltage	Verified by one of these dielectric tests: 1200V AC for 1 s or 1697V DC for 1 s, output point to bus 75V DC working voltage (IEC Class II reinforced insulation)

- (1) Triac outputs turn on and off at AC line zero cross.
- (2) To limit the effects of leakage current through solid-state outputs, a loading resistor can be connected in parallel with your load. For 120V AC operation, use a 15 k $\Omega$ , 2 W resistor. For 240V AC operation, use a 5 k $\Omega$ , 5 W resistor.
- (3) If you connect surge suppressors across your external load, you extend the life of the triac outputs.

### Transistor Output Transient Pulses - 1769-BOOLEAN

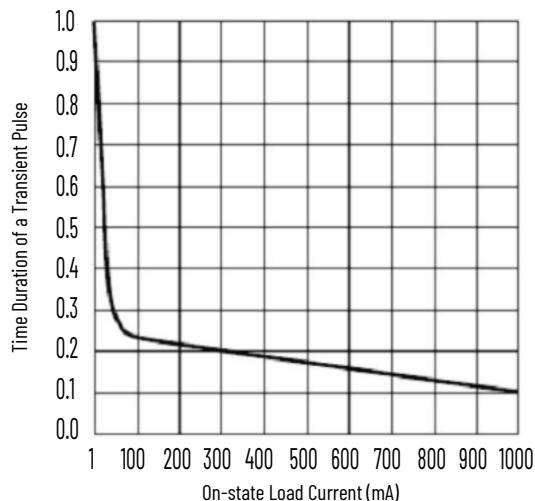

### Temperature Derating - 1769-BOOLEAN

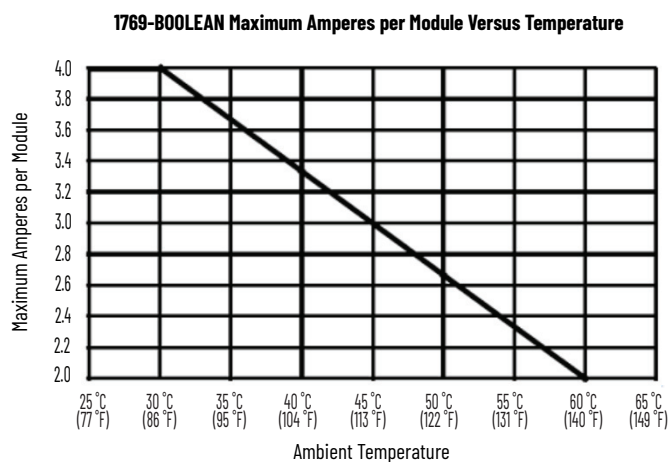
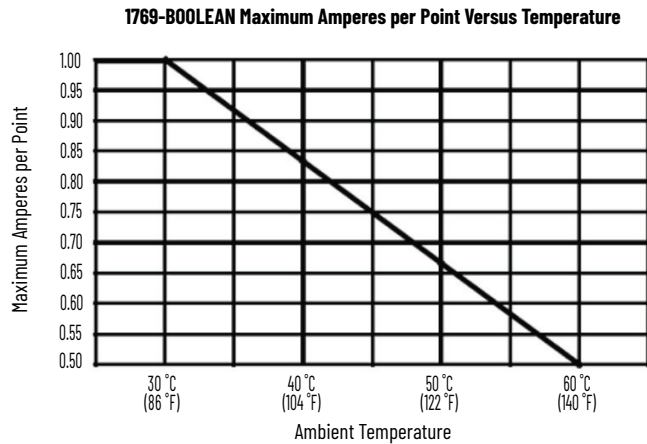

For Environmental Specifications, see [page 2](#).

For Certifications, see [page 3](#).

# 1769-HSC

## Compact high-speed counter module

Use the 1769-HSC module when you need:

- A counter module that can react to high-speed input signals.
- To generate rate and time-between-pulses (pulse interval) data.
- One or two channels of quadrature or four channels of pulse/count inputs.

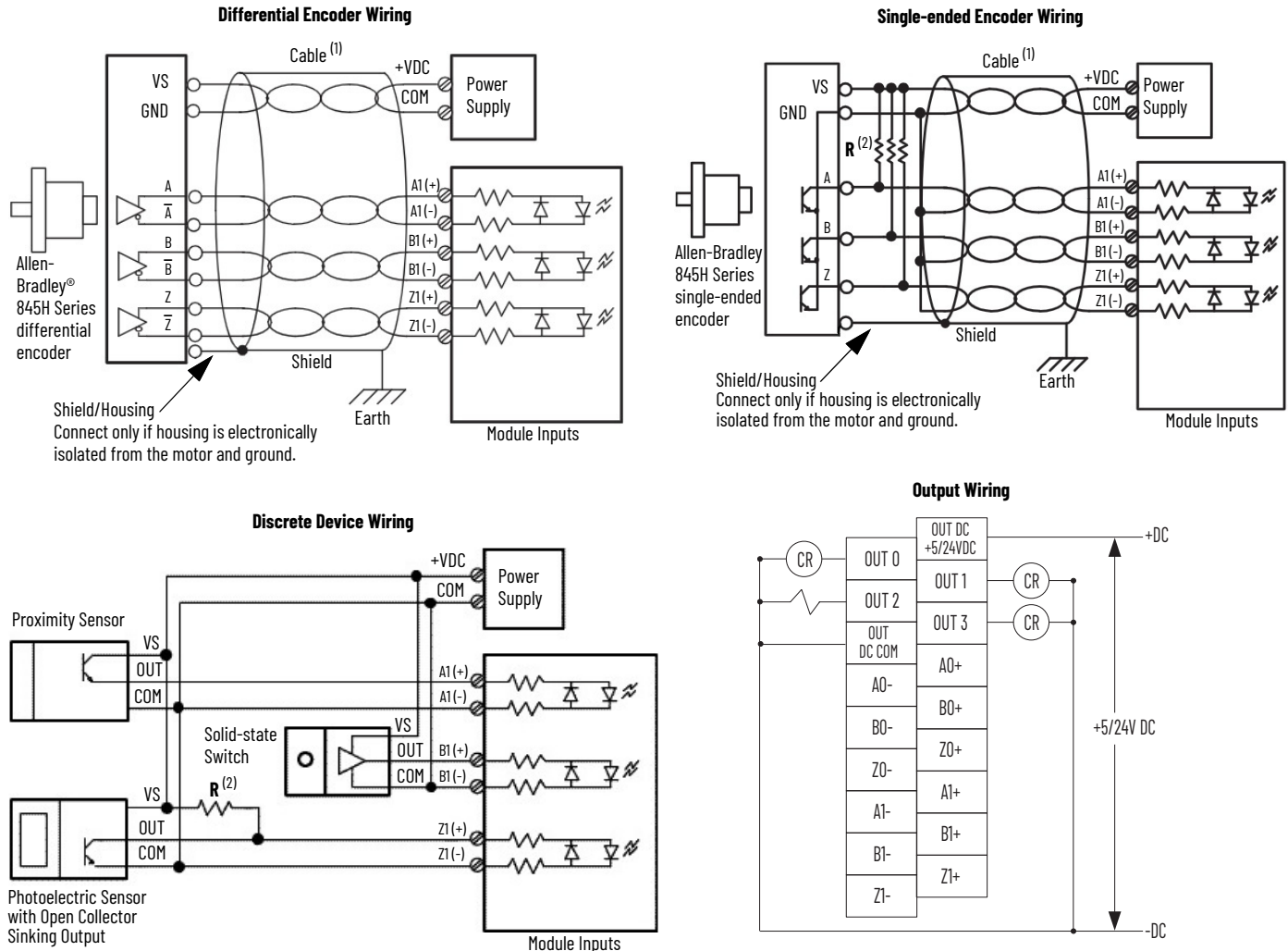

- (1) See the encoder manual for proper cable type. Use a twisted-pair, individually shielded cable with a maximum length of 300 m (1000 ft).  
 (2) External resistors are required if they are not internal to the encoder. The pull-up resistor (R) value depends on the power supply value. To calculate the maximum resistor value, use this formula:

$$R = \frac{(V_{dc} - V_{min})}{I_{min}}$$

where:

- R = maximum pull-up resistor value
- VDC = power supply voltage
- Vmin = 2.6V DC
- min = 6.8 mA

Power Supply Voltage (V DC)	Pull-up Resistor Value Max (R) <sup>(1)</sup>
5V DC	352 Ω
12V DC	1382 Ω
24V DC	3147 Ω

(1) Resistance values can change, depending upon your application.

The minimum resistor (R) value depends on the current sinking capability of the encoder. See the documentation for your encoder for more information.

## Technical Specifications – 1769-HSC

Attribute	1769-HSC
Bus current draw	425 mA, 5V DC 0 mA, 24V DC
Heat dissipation, max	6.21 W, the watts per point, plus the min watts, with all points energized
Isolation voltage	75V (continuous), reinforced insulation type, channel-to-system and channel-to-channel Type tested at 1200V AC for 2 s
Weight, approx	309 g (0.681 lb)
Dimensions (HxWxD), approx	118 x 35 x 87 mm (4.65 x 1.38 x 3.43 in.) Height with mounting tabs 138 mm (5.43 in.)
Slot width	1
Module location	DIN rail or panel mount
Power supply	1769-PA2, 1769-PB2, 1769-PA4, 1769-PB4
Power supply distance rating	4 modules
Terminal screw torque	0.68 N·m (6 lb·in)
Retaining screw torque	0.46 N·m (4.1 lb·in)
Wire size	0.32...2.1 mm <sup>2</sup> (22...14 AWG) solid copper wire 0.32...1.3 mm <sup>2</sup> (22...16 AWG) stranded copper wire rated at 90 °C (194 °F) insulation max
Wire type	Cu-90 °C (194 °F)
Recommended cable	Individually shielded, twisted-pair cable (or the type recommended by the encoder or sensor manufacturer)
Wiring Category <sup>(1)</sup>	2 - on signal ports
Vendor ID code	1
Product type code	109
Product code	19
Enclosure type rating	None (open-style)

(1) Use this Conductor Category information to plan conductor routing. See the Industrial Automation Wiring and Grounding Guidelines, publication [1770-4.1](#).

## 1769-HSC Input Specifications

Attribute	1769-HSC
Inputs	2 quadrature (ABZ) differential inputs
Input voltage range <sup>(1)</sup>	2.6...30V DC
On-state voltage, max	30V DC
On-state voltage, min	2.6V DC
On-state current, min	6.8 mA
Off-state voltage, max	1.0V DC
Off-state current, max	1.5 mA
Off-state leakage current, max	1.5 mA
Input current, max	15 mA
Input current, min	6.8 mA
Input impedance	1950 Ω
Pulse width, min	250 ns
Phase separation, min	131 ns
Input frequency, max	1 MHz
Isolation voltage	Verified by one of these dielectric tests: 1200V AC or 1697V DC for 1 s, input to bus and input to input 75V DC working voltage (IEC Class II reinforced insulation)

(1) See Compact I/O Modules Installation Instructions, publication [1769-IN088](#).

## 1769-HSC Output Specifications

Attribute	1769-HSC
Outputs	16 total, 4 physical and 12 virtual
Output voltage range	5...30V DC
On-state voltage, max	User power - 0.1V DC
On-state output current per point, max	1 A, 30V DC, 40 °C 0.5 A, 5V DC, 60 °C
On-state output current per module, max	4 A, 30V DC, 40 °C 2 A, 5V DC, 60 °C
On-state output current, min	1 mA
On-state voltage drop, max	0.5V DC
Off-state leakage current, max	5 μA
Turn-on time, max	400 μs <sup>(1)</sup>
Turn-off time, max	200 μs
Reverse polarity protection	30V DC
Isolation voltage	Verified by one of these dielectric tests: 1200V AC or 1697V DC for 1 s, output to bus 75V DC working voltage (IEC Class II reinforced insulation)

(1) Maximum turn-on time applies to an output voltage range of 5...7V DC. For output voltages greater than 7V DC, the maximum turn-on time is 200 μs.

For **Temperature Derating**, see [page 59](#).

For **Environmental Specifications**, see [page 2](#).

For **Certifications**, see [page 3](#).

## Temperature Derating - 1769-HSC

**Maximum Input Voltage - 24V DC Operation**  
Voltage Derating Based on Temperature

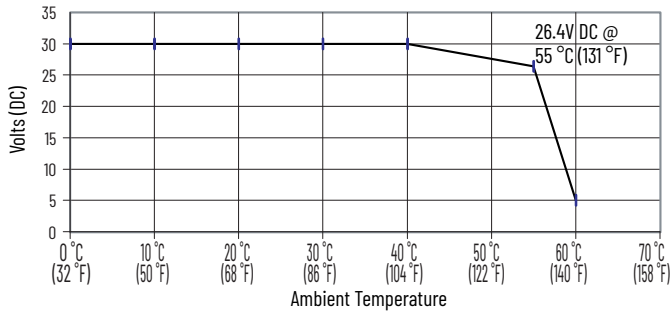

Temperature	Derated Voltage <sup>(1)</sup>
0...40 °C (32...104 °F)	30V DC
55 °C (131 °F)	26.4V DC
60 °C (140 °F)	5V DC

(1) Input voltage derating between 55...60°C is achieved by using a dropping resistor. For 24V DC input voltage, use a 2.4 kΩ, ½ Watt resistor. For input voltages other than 24V DC, use a ½ Watt resistor with value: 125 x (V<sub>in</sub> - 5V).

**Maximum Output Voltage - 24V DC Operation**  
Voltage Derating Based on Temperature

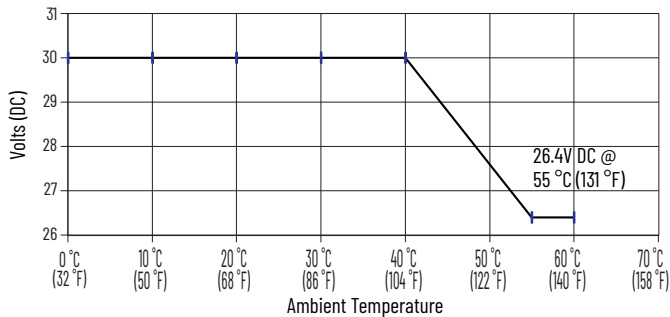

Temperature	Derated Voltage
0...40 °C (32...104 °F)	30V DC
55...60 °C (131...140 °F)	26.4V DC

**Maximum Output Current per Point - 5V DC Operation**  
Voltage Derating Based on Temperature

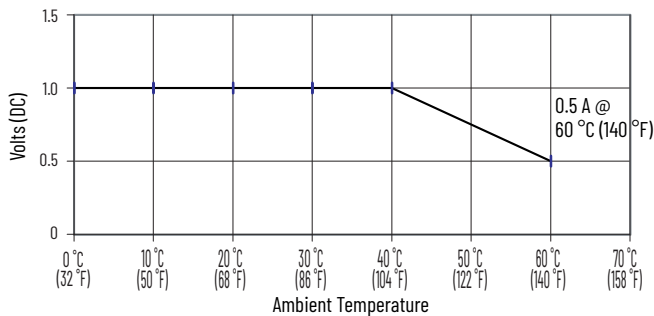

Temperature	Derated Current
0...40 °C (32...104 °F)	1 A
60 °C (140 °F)	0.5 A

**Maximum Output Current per Module - 5V DC Operation**  
Voltage Derating Based on Temperature

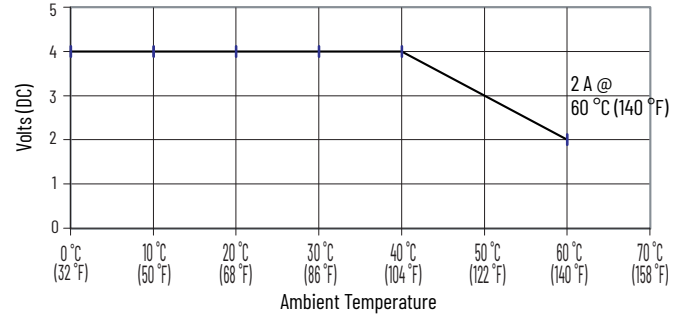

Temperature	Derated Current
0...40 °C (32...104 °F)	4 A
60 °C (140 °F)	2 A

**Maximum Output Current per Point - 24V DC Operation**  
Current Derating Based on Temperature

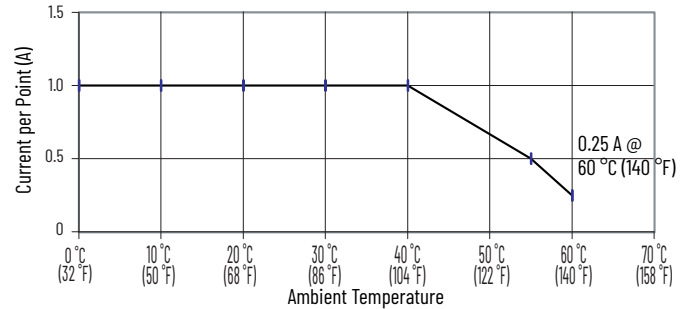

Temperature	Derated Current
0...40 °C (32...104 °F)	1 A
55 °C (131 °F)	0.5 A
60 °C (140 °F)	0.25 A

**Maximum Output Current per Module - 24V DC Operation**  
Current Derating Based on Temperature

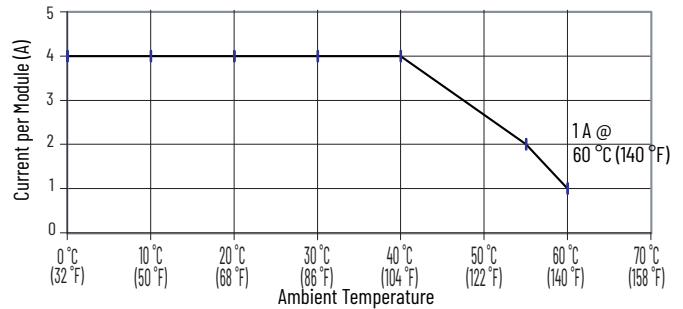

Temperature	Derated Current
0...40 °C (32...104 °F)	4 A
55 °C (131 °F)	2 A
60 °C (140 °F)	1 A

## 1769-SM2

### Compact I/O to DSI module

The 1769-SM2 Compact I/O to DSI module provides a Compact I/O connection for PowerFlex™ 4-Class drives, and to other Modbus RTU follower devices (like PowerFlex 7-class drives with 20-COMM-H RS-485 HVAC adapters). It can be used with MicroLogix 1500 or CompactLogix controllers, or a remote 1769-based adapter such as the 1769-ADN.

### Technical Specifications - 1769-SM2

Attribute	1769-SM2
Drive Protocol	DSI or Modbus RTU Master
Data Rates	DSI Operation: 19,200 bps Modbus RTU Master Operation: 300, 600, 1200, 2400, 4800, 9600, 19200, or 38,400 bps
Current Draw, module data only (no channel data)	350 mA @ 5V DC and 0 mA @ 24V DC supplied by the Compact I/O power supply
Dimensions (HxWxD), approx	118 x 35 x 87 mm (4.65 x 1.38 x 3.43 in.) Height with mounting tabs 138 mm (5.43 in.)
Weight, approx	142g (5 oz.)

### Cable Requirements - 1769-SM2

Cable	Maximum cable distance between PowerFlex 4-Class drives and the 1769-SM2 <sup>(1)(2)</sup>
8-conductor cables used in Single-drive mode	10 m (32.8 ft)
2-conductor, twisted-pair, network wiring used with RJ45 two-position terminal blocks (AK-U0-RJ45-TB2P) in Single or Multi-drive mode	1219 m (4000 ft) (standard RS-485 specifications)

- (1) 1202-Hxx extension cables are recommended for extending the 1202-Cxx cable length.  
(2) You must follow common system wiring practices and route cables away from sources of EMI.

### Environmental Specifications - 1769-SM2

Attribute	1769-SM2
Temperature, operating	-10...+50°C (14...122°F)
Temperature, storage	-40...+85°C (-40...+185°F)
Relative Humidity	-5...+95% noncondensing
Atmosphere	<b>Important:</b> The 1769-SM2 must not be installed in an area where the ambient atmosphere contains volatile or corrosive gas, vapors, or dust. If the module is not installed, it must be stored in an area where it is not exposed to a corrosive atmosphere.
Vibration, operating	5g, 10 @ 500 Hz
Vibration, nonoperating	5g, 5 @ 2000 Hz
Shock, operating	30g, 11 ms
Shock, nonoperating	50g, 11 ms

For Certifications, see [page 3](#).

## Compact I/O Mounting Dimensions

### Single Slot Dimensions

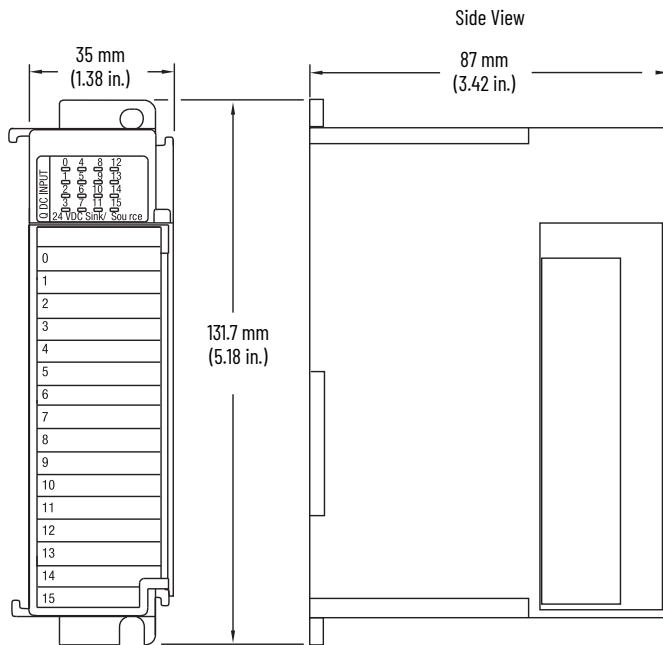

### One-and-a-half Slot Dimensions

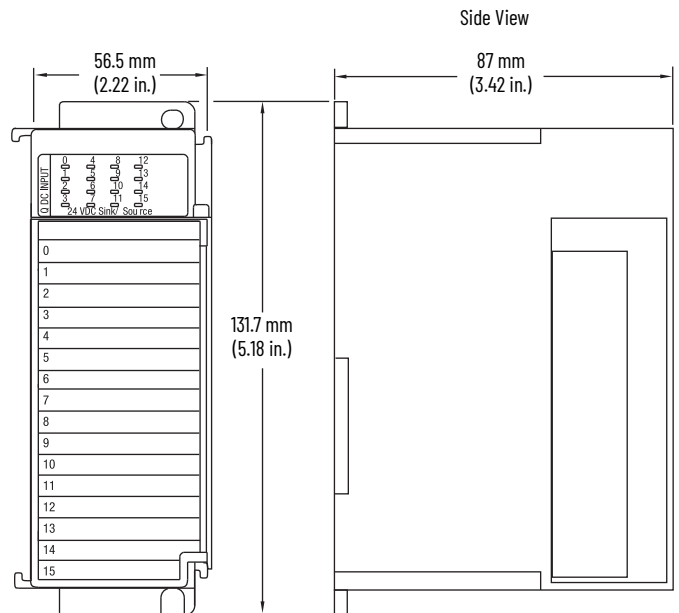

## Compact I/O Accessories

Category	Cat. No.	Description	Page
End cap	1769-ECL, 1769-ECLK	Left-end cap for Compact I/O system	62
	1769-ECR, 1769-ECRK	Right-end cap for Compact I/O system	
Expansion cable	1769-CLL1	Left bank-to-left bank expansion 305 mm (1 ft)	63
	1769-CLL3	Left bank-to-left bank expansion 1 m (3.28 ft)	
	1769-CRR1	Right bank-to-right bank expansion 305 mm (1 ft)	
	1769-CRR3	Right bank-to-right bank expansion 1 m (3.28 ft)	
	1769-CRL1	Right bank-to-left bank expansion 305 mm (1 ft)	
	1769-CRL3	Right bank-to-left bank expansion 1 m (3.28 ft)	
Replacement terminal block	1769-RTBN10	10-pin NEMA terminal block	-
	1769-RTBN18	18-pin NEMA terminal block	-
Replacement door labels	1769-RL1	Replacement door labels for digital I/O, 2 per kit	-
	1769-RL2	Replacement door labels for analog and specialty I/O, 2 per kit	-
Replacement doors	1769-RD	Door replacement kit, 2 per kit	-
Replacement connector kit	1746-N3	Connector kit to terminate a cable, which connects field I/O devices to 32-point I/O modules, 1 connector and 40 terminals	-

## End Caps

The final I/O bank in a Compact system needs an end cap on the end without an expansion cable. The 1769-L23x controller comes with a right-end cap, so you do not need to order one separately.

### Technical Specifications - 1769-ECL, 1769-ECLK, 1769-ECR, 1769-ECRK

Attribute	1769-ECL, 1769-ECLK	1769-ECR, 1769-ECRK
Current draw @ 5.1V	5 mA	
Current draw @ 24V	0 mA	
Weight, approx	130 g (0.286 lb)	
Location	Left end	Right end
North American temp code	T3C	
IEC temperature code	N/A	T4
Enclosure type rating	None (open-style)	None (open-style)

### Certifications - 1769-ECL, 1769-ECLK, 1769-ECR, 1769-ECRK

Certification <sup>(1)</sup>	1769-ECL, 1769-ECLK	1769-ECR, 1769-ECRK
c-UL-us	UL Listed for Class I, Division 2 Group A, B, C, D Hazardous Locations, certified for U.S. and Canada. See UL File E334470	
CE	European Union 2014/30/EU EMC Directive, compliant with: EN 61000-6-2; Industrial Immunity EN 61000-6-4; Industrial Emissions European Union 2011/65/EU RoHS, compliant with: EN IEC 63000; Technical documentation	
RCM	Australian Radiocommunications Act, compliant with: EN 61000-6-4; Industrial Emissions	
EX	–	European Union 2014/34/EU ATEX Directive, compliant with: EN 60079-0; General Requirements EN 60079-7; Explosive atmospheres. Equipment protection by increased safety "e" • II 3 G Ex ec IIC T4 Gc • DEMKO 12 ATEX 1116807X (from Rev. 5) • UL22UKEX2516X (from Rev. 0)
IECEX	–	IEC 60079-7; Explosive atmospheres. Equipment protection by increased safety "e" (Zone 2) IEC 60079-0; General Requirements (Zone 2) IECEx UL 21.0112X from (Rev.1)
CCC	–	CNCA-C23-01 强制性产品认证实施规则 防爆电气 CNCA-C23-01 CCC Implementation Rule Explosion-Proof Electrical Products
KC	Korean Registration of Broadcasting and Communications Equipment, compliant with: Article 58-2 of Radio Waves Act, Clause 3	
UKCA	2016 No. 1091 Electromagnetic Compatibility Regulations (EMC) 2012 No. 3032 - Restriction of the Use of Certain Hazardous Substances in Electrical and Electronic Equipment Regulations 2016 No. 1107 Equipment and Protective Systems Intended for Use in Potentially Explosive Atmospheres Regulations (Ex)	
Morocco	Arrêté ministériel n° 6404-15 du 1 er muharram 1437 Arrêté ministériel n° 6404-15 du 29 ramadan 1436	

(1) When marked. See the Product Certification link at [rok.auto/certifications](http://rok.auto/certifications) for Declarations of Conformity, Certificates, and other certification details.

### Mounting Dimensions - 1769-ECL, 1769-ECLK

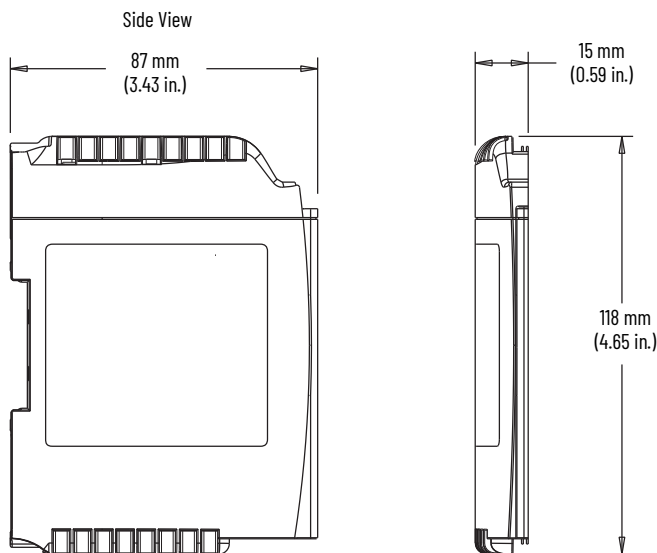

### Mounting Dimensions - 1769-ECR, 1769-ECRK

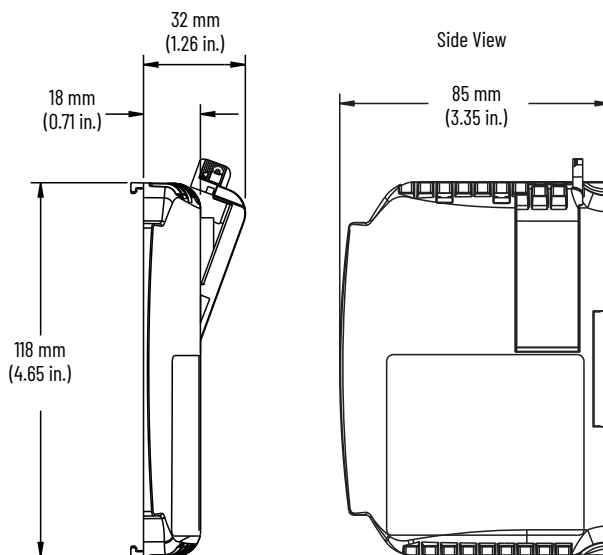

## Expansion Cables

The 1769-CLLx, -CRRx, and -CRLx cables extend the 1769 bus communication lines. A maximum of two cables can be used in a 1769 system, which allows for three groups or banks of I/O modules. Each bank requires its own power supply.

### Technical Specifications - 1769-CLLx, 1769-CRRx, 1769-CRLx

Attribute	1769-CLL1, 1769-CRR1, 1769-CRL1	1769-CLL3, 1769-CRR3, 1769-CRL3
Weight, approx	300 g (0.66 lb)	350 g (0.77 lb)
Length	305 mm (1 ft)	1 m (3.28 ft)

### Certifications - 1769-CLLx, 1769-CRRx, 1769-CRLx

Certification <sup>(1)</sup>	1769-CLLx, 1769-CRRx, 1769-CRLx
c-UL-us	UL Listed for Class I, Division 2 Group A,B,C,D Hazardous Locations, certified for U.S. and Canada. See UL File E334470.
CE	European Union 2014/30/EU EMC Directive, compliant with: EN 61000-6-2; Industrial Immunity EN 61000-6-4; Industrial Emissions European Union 2011/65/EU RoHS, compliant with: EN IEC 63000; Technical documentation
RCM	Australian Radiocommunications Act, compliant with: EN 61000-6-4; Industrial Emissions
KC	Korean Registration of Broadcasting and Communications Equipment, compliant with: Article 58-2 of Radio Waves Act, Clause 3
UKCA	2016 No. 1091 Electromagnetic Compatibility Regulations (EMC) 2012 No. 3032 - Restriction of the Use of Certain Hazardous Substances in Electrical and Electronic Equipment Regulations
Morocco	Arrêté ministériel n° 6404-15 du 1 er muharram 1437 Arrêté ministériel n° 6404-15 du 29 ramadan 1436

(1) When marked. See the Product Certification link at [rok.auto/certifications](http://rok.auto/certifications) for Declarations of Conformity, Certificates, and other certification details.

### Dimensions - 1769-CLLx, 1769-CRRx, 1769-CRLx

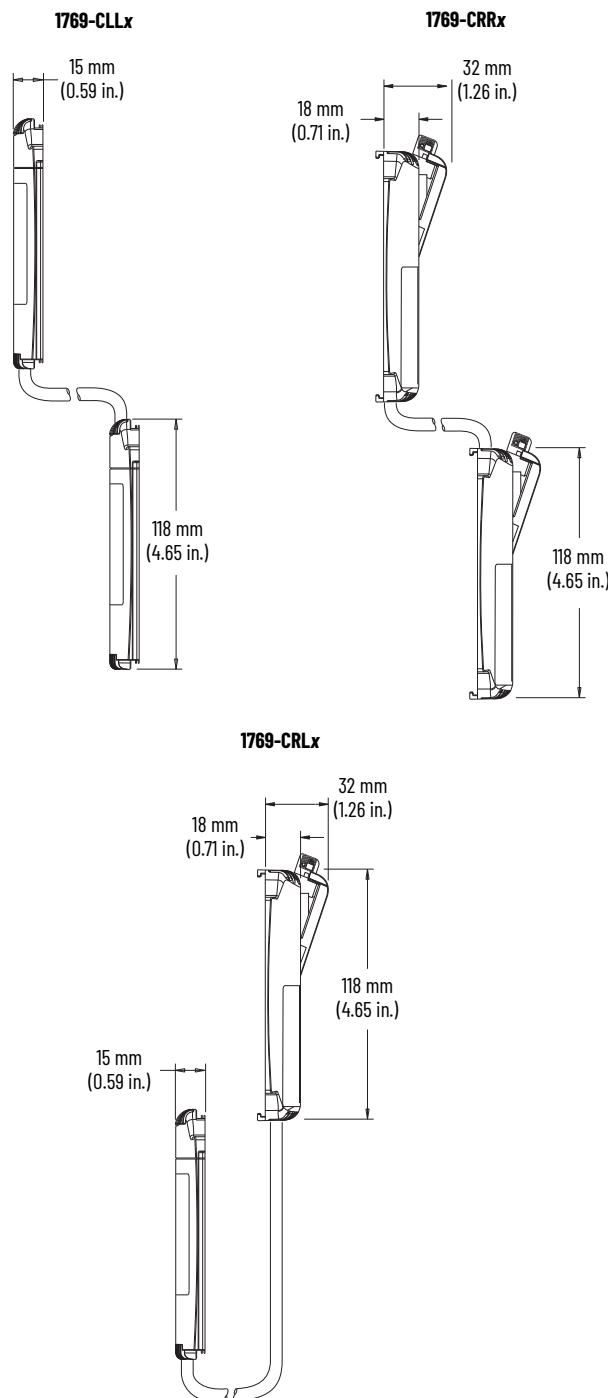

## Wiring Systems

You can buy removable terminal blocks (RTBs) and connect the wires yourself or you can buy a wiring system of:

- Interface modules (IFMs) that provide the output terminal blocks for digital I/O modules. Use the pre-wired cables that match the I/O module to the IFM.
- Analog interface modules (AIFMs) that provide the output terminal blocks for analog I/O modules. Use the pre-wired cables that match the I/O module to the AIFM.
- I/O module-ready cables. One end of the cable assembly is an RTB that plugs into the front of the I/O module. The other end has individually color-coded conductors that connect to a standard terminal block.

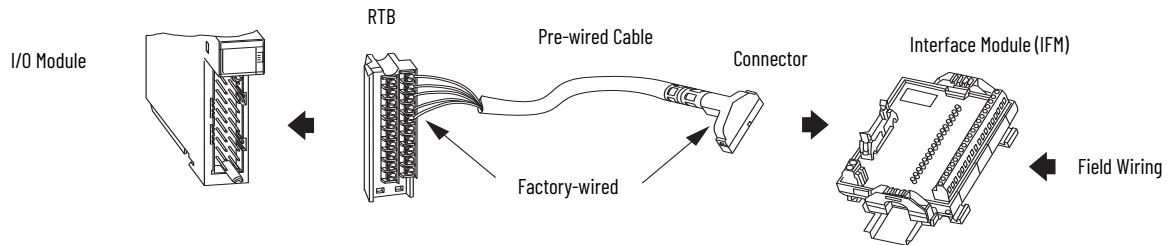

## Additional Resources

These documents contain additional information concerning related products from Rockwell Automation. You can view or download publications at [rok.auto/literature](http://rok.auto/literature).

Resource	Description
Compact I/O Modules Installation Instructions, publication <a href="#">1769-IN088</a>	Provides installation instructions for all 1769 Compact I/O modules.
CompactLogix System User Manual, publication <a href="#">1769-UM007</a>	Provides information about how to place, configure, and monitor 1769 Compact I/O modules in a CompactLogix system with 1769-L20, and 1769-L30 controllers.
Industrial Automation Wiring and Grounding Guidelines, publication <a href="#">1770-4.1</a>	Provides general guidelines for installing a Rockwell Automation industrial system.
Product Certifications website, <a href="http://rok.auto/certifications">rok.auto/certifications</a> .	Provides declarations of conformity, certificates, and other certification details.

# Rockwell Automation Support

Use these resources to access support information.

<b>Technical Support Center</b>	Find help with how-to videos, FAQs, chat, user forums, Knowledgebase, and product notification updates.	<a href="http://rok.auto/support">rok.auto/support</a>
<b>Local Technical Support Phone Numbers</b>	Locate the telephone number for your country.	<a href="http://rok.auto/phonesupport">rok.auto/phonesupport</a>
<b>Technical Documentation Center</b>	Quickly access and download technical specifications, installation instructions, and user manuals.	<a href="http://rok.auto/techdocs">rok.auto/techdocs</a>
<b>Literature Library</b>	Find installation instructions, manuals, brochures, and technical data publications.	<a href="http://rok.auto/literature">rok.auto/literature</a>
<b>Product Compatibility and Download Center (PCDC)</b>	Download firmware, associated files (such as AOP, EDS, and DTM), and access product release notes.	<a href="http://rok.auto/pcdc">rok.auto/pcdc</a>

## Documentation Feedback





Your comments help us serve your documentation needs better. If you have any suggestions on how to improve our content, complete the form at [rok.auto/docfeedback](http://rok.auto/docfeedback).

Allen-Bradley, Compact I/O, CompactLogix, expanding human possibility, MicroLogix, PowerFlex, Rockwell Automation, RSLogix 5000, and SMC-50 are trademarks of Rockwell Automation, Inc. DeviceNet is a trademark of ODVA, Inc.

Trademarks not belonging to Rockwell Automation are property of their respective companies.

Rockwell Automation maintains current product environmental compliance information on its website at [rok.auto/pec](http://rok.auto/pec).

Rockwell Otomasyon Ticaret A.Ş. Kar Plaza İş Merkezi E Blok Kat:6 34752, İçerenköy, İstanbul, Tel: +90 (216) 5698400 EEE Yönetmeliğine Uygundur

Connect with us.    

[rockwellautomation.com](http://rockwellautomation.com) — expanding **human possibility**<sup>®</sup>

AMERICAS: Rockwell Automation, 1201 South Second Street, Milwaukee, WI 53204-2496 USA, Tel: (1) 414.382.2000, Fax: (1) 414.382.4444

EUROPE/MIDDLE EAST/AFRICA: Rockwell Automation NV, Pegasus Park, De Kleetlaan 12a, 1831 Diegem, Belgium, Tel: (32) 2663 0600, Fax: (32) 2 663 0640

ASIA PACIFIC: Rockwell Automation SEA Pte Ltd, 2 Corporation Road, #04-05, Main Lobby, Corporation Place, Singapore 618494, Tel: (65) 6510 6608, FAX: (65) 6510 6699

UNITED KINGDOM: Rockwell Automation Ltd., Pitfield, Kiln Farm, Milton Keynes, MK11 3DR, United Kingdom, Tel: (44)(1908) 838-800, Fax: (44)(1908) 261-917

Publication 1769-TD006H-EN-P - November 2023

Supersedes Publication 1769-TD006G-EN-P - March 2020

Copyright © 2023 Rockwell Automation, Inc. All rights reserved. Printed in the U.S.A.