

# PowerFlex 520-series AC Drive Specifications

Bulletin Numbers 25A series B, 25B

Topic	Page
Summary of Changes	2
Product Overview	3
Catalog Number Explanation	9
Technical Specifications	10
Environmental Specifications	12
Certifications	13
Product Selection	14
Design Considerations	16
Fuses and Circuit Breaker Ratings	25
Accessories and Dimensions	33
Safe Torque Off Function	46
Additional Resources	51



Drive Features: AppView®, CustomView™, QuickView®, and MainsFree™ configuration and programming tools.

---

# Summary of Changes

This publication contains the following new or updated information. This list includes substantive updates only and is not intended to reflect all changes.

<b>Topic</b>	<b>Page</b>
Updated Certifications	13
Updated Fuses and Circuit Breaker tables	26...32

Rockwell Automation recognizes that some of the terms that are currently used in our industry and in this publication are not in alignment with the movement toward inclusive language in technology. We are proactively collaborating with industry peers to find alternatives to such terms and making changes to our products and content. Please excuse the use of such terms in our content while we implement these changes.

## Product Overview

The PowerFlex® 520-series AC drive delivers an innovative design that is remarkably versatile and can accommodate systems ranging from standalone machines to simple system integration. The PowerFlex 523 drive provides general-purpose control for applications that range up to 30 HP and 22 kW. The PowerFlex 525 drive provides maximum flexibility and performance ranging up to 30 HP and 22 kW.

By combining various motor control options, communications, energy savings, and standard safety features in a cost-effective drive, the PowerFlex 520-series drive is suitable for a wide array of applications.

Maximize your system performance and productivity by taking advantage of the following key features offered in a PowerFlex 520-series drive.

## PowerFlex 520-series AC Drives Feature

### Modular Design

- Detachable control module and power module allow **simultaneous configuration and installation**.
- Each drive has a **standard control module** that is used across the entire power range.
- **MainsFree configuration** allows you to simply connect your control module to a PC with a standard USB cable and quickly upload, download, and update the drive with new settings.
- **Support for accessory cards** without affecting the footprint.  
(PowerFlex 523 drives support one, PowerFlex 525 drives support two)

### Packaging and Mounting

- Installation can be quick and easy using the **DIN rail mounting** feature on A, B, and C frame drives. Panel mounting is also available, providing added flexibility.
- **Zero Stacking** is allowed for ambient temperatures up to 45 °C (113 °F), saving valuable panel space.
- **Integral filtering** is available on all 200V and 400V ratings, providing a cost-effective means of meeting EN61800-3 Category C2 and C3 EMC requirements. External filters provide compliance to EN61800-3 Category C1, C2, and C3 EMC requirements for all PowerFlex 520-series ratings.
- An optional **IP 30, NEMA/UL Type 1 conduit box** is easily adapted to the standard IP 20 (NEMA Type Open) product, providing increased environmental ratings.

### Optimized Performance

- **Removable MOV** to ground provides trouble-free operation when used on ungrounded distribution systems.
- A **relay precharge** limits inrush current.
- **Integral brake transistor**, available on all ratings, provides dynamic braking capability with simple low-cost brake resistors.
- A jumper to switch between **24V DC sink or source control** for control wiring flexibility.
- **Dual Overload Rating** available for drives above 15 HP/11 kW. Normal duty: 110% overload for 60 seconds or 150% for 3 seconds. Heavy duty: 150% overload for 60 seconds or 180% overload (200% programmable) for 3 seconds provides robust overload protection.
- **Adjustable PWM frequency up to 16 kHz** delivers quiet operation.

# PowerFlex 520-series AC Drive Advanced Features

## Control Performance

- **Various motor control options, including:**
  - Volts per Hertz (VHz)
  - Sensorless Vector Control (SVC)
  - Closed loop velocity vector control (PowerFlex 525 drives only)
  - Permanent Magnet motor control (PowerFlex 525 drives only)
- **Various positioning controls, including:**
  - PointStop™ stops motor load in a consistent position without encoder feedback
  - Closed loop feedback with an optional encoder card (PowerFlex 525 drives only)
  - Point-to-point positioning mode (PowerFlex 525 drives only)
- **Integral PID** functionality enhances application flexibility (PowerFlex 523 drives have one PID loop, PowerFlex 525 drives have two PID loops)

## I/O Wiring

### PowerFlex 523

- **One Analog Input** (unipolar voltage or current) independently isolated from the rest of the drive I/O.
- **Five Digital Inputs** (four programmable) provide application versatility.
- **One Analog Output**<sup>(a)</sup> that is jumper selectable between either 0...10V or 0...20 mA. This scalable, 10-bit output is suitable for metering or as a speed reference to another device.
- **One Relay Output** (form C) can be used to indicate various drive, motor, or logic conditions.

### PowerFlex 525

- **Two Analog Inputs** (one unipolar and one bipolar) are independently isolated from the rest of the drive I/O. These inputs can be toggled via a digital input.
- **Seven Digital Inputs** (six programmable) provide application versatility.
- **One Analog Output** that is jumper selectable between either 0...10V or 0...20 mA. This scalable, 10-bit output is suitable for metering or as a speed reference to another drive.
- **Two Opto Outputs and two Relay Outputs** (one form A and one form B) can be used to indicate various drive, motor or logic conditions.

**PowerFlex 523 Series B Control I/O Wiring Block Diagram**

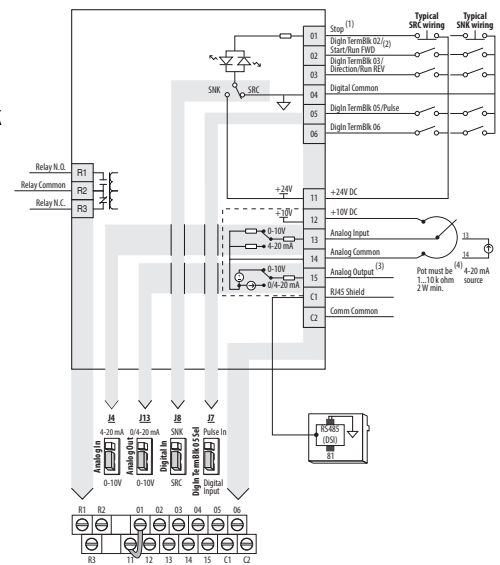

**PowerFlex 525 Control I/O Wiring Block Diagram**

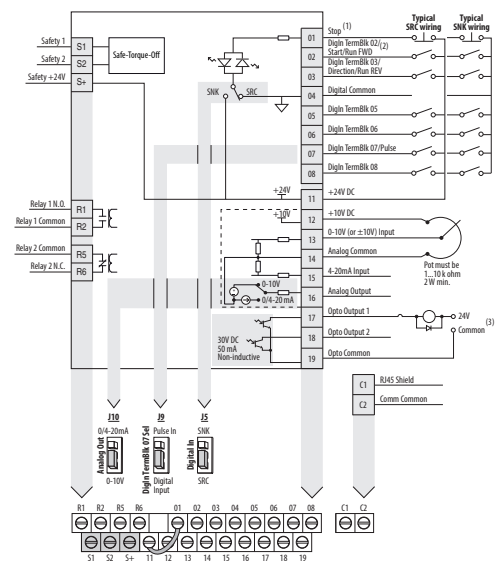

(a) Analog output (terminal 15) is only available on PowerFlex 523 series B drive and requires firmware 3.001 and later to configure the analog output parameters.

## Communications

- **Embedded EtherNet/IP™ port** allows easy configuration, control, and collection of drive data over the network. (PowerFlex 525 drives only)
- **Dual-port EtherNet/IP option card** supports Device Level Ring (DLR) topologies, providing **fault-tolerant connectivity** for optimum drive availability.
- **Integral RS485/DSI communications** enable the drives to be used in a multi-drop network configuration.
- Optional communication cards such as **DeviceNet®**, and **PROFIBUS DP** can improve machine performance.
- **Online EDS file creation** with RSNetWorx™ provides ease of setup on a network.

## Optimized for Common DC Bus Installations

### *Enhanced Control of Internal Precharge*

**Common DC Bus** offers additional inherent breaking capabilities by using all drives/loads on the bus for energy absorption, which delivers higher efficiency and cost savings. The PowerFlex 520-series drive has been optimized for use in **Common DC Bus** or **Shared DC Bus installations**.

- Configurable precharge control using digital inputs
- Direct DC Bus connection to power terminal blocks

## Improved Ride-through

### *Operation Down to 1/2 Line Voltage*

The PowerFlex 520-series drive allows for the selection of **1/2 DC Bus operation**, for use in critical applications where continued drive output is desired even in the event of brown out or low voltage conditions. The PowerFlex 520-series drive also supports **enhanced inertia ride-through** for additional low voltage mitigation.

- Selectable 1/2 line voltage operation
- Increased power loss ride-through

## Additional Features of PowerFlex 525 Drives

### *Closed Loop Feedback*

#### **Encoder/Pulse Train Input**

The PowerFlex 525 drive allows for configurable closed loop control with an optional encoder card for either speed or position feedback for improved speed regulation, basic position control, or other pulse inputs for motor control.

- Improved speed regulation
- Basic position control

Basic Position Control

Local Position Control

- Position regulator with StepLogic®
- Eight positions (local logic)

Outer Position Control Loop

- **Analog input bipolar mode** offers improved zero-cross performance
- **Simple motion control** applications with more complex position profiles
- **Speed reference** supplied to drive via Analog Input or multiple fieldbus network options
- **Speed ratio** available for simple draw applications

Feedback Details

Line Driver Type Incremental Encoder Option Card

- Quadrature (dual channel) or Single Channel
- 5V/12V DC supply, 10 mA min per channel
- Single Ended or Differential (A, B Channel)
- Duty Cycle of 50%, +10%
- Input Frequency up to 250 kHz

Pulse Train Input

- Configurable Input Voltage 5V/12V/24V DC autodetects
- Input Frequency up to 100 kHz

Encoder Wiring Examples

I/O	Connection Example	I/O	Connection Example
<b>Encoder Power - Internal Drive Power</b> Internal (drive) 12V DC, 250 mA		<b>Encoder Power - External Power Source</b>	
<b>Encoder Signal - Single-Ended, Dual Channel</b>		<b>Encoder Signal - Differential, Dual Channel</b>	

Safety Inside using Safe-Torque-Off Function

Safe Torque Off (STO) is a standard safety feature of the PowerFlex 525 drive to help protect personnel and equipment. STO allows you to restart your application faster after a safety-related situation.

- Safe Torque Off functionality **removes rotational power without powering down the drive.**
- Embedded safety **reduces wiring and saves on installation space.**
- Meets ISO 13849-1 standards and provides safety ratings up to and including **SIL 2/PLd.**

## Communications and Software

### Versatile Programming and Network Solutions

- PowerFlex 520-series drives are compatible with any device that acts as an RTU **Master** and supports standard 03 and 06 RTU commands.
- A network can be configured using PowerFlex 520-series drives for **high performance and flexible configuration** capabilities.
  - Embedded port for EtherNet/IP (PowerFlex 525 drives only)
  - EtherNet/IP dual-port option card
  - DeviceNet option card
  - PROFIBUS DP option card
- A **multi-drive solution** can be reached using one PowerFlex 520-series drive, with the ability for up to five drives to reside on one node.
- **Integral RS-485** communications enable the drives to be used in a multi-drop network configuration. A serial converter module (SCM) provides connectivity to any controller with a DF1 port. The SCM can be removed if the controller acts as an RTU Master.

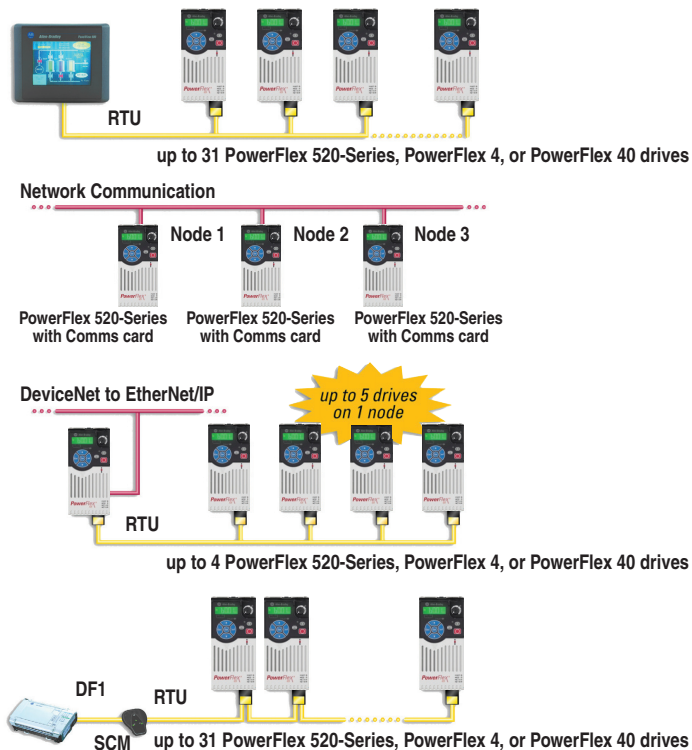

### PC Programming Software

#### Connected Components Workbench™

- Supports plug and play connectivity through a standard USB connection.
- AppView tool provides parameter groups for several of the most common applications.
- Create and save custom parameter groups using the CustomView tool.
- Supports PowerFlex drives, Micro800™ controllers and PanelView™ component graphic terminals.

#### Studio 5000 Logix Designer®

- Add-on Profiles (AOPs) for PowerFlex 520-series AC drives provide seamless integration into the Logix environment.
- Configuration files from the Studio 5000 Logix Designer<sup>(a)</sup> application can be transferred directly to the PowerFlex 520-series drive over EtherNet/IP.
- Automatic Device Configuration (ADC) uploads configuration parameters to a replaced drive, minimizing the need for a manual reconfiguration.

(a) The Studio 5000 Logix Designer application is the rebranding of RSLogix 5000® software. You can also use RSLogix 5000 version 17 or greater.

## PowerFlex 523 Drive Family



## PowerFlex 525 Drive Family



# Catalog Number Explanation

1-3	4	5	6-8	9	10	11	12	13	14
25B	-	B	2P3	N	1	1	4	-	-
Drive	Dash	Voltage Rating	Rating	Enclosure	Reserved	Emission Class	Reserved	Dash	Dash

Code	Type
25A	PowerFlex 523
25B	PowerFlex 525

Code	EMC Filter
0	No Filter
1	Filter

Code	Braking
4	Standard

Code	Voltage	Phase
V	120V AC	1
A	240V AC	1
B	240V AC	3
D	480V AC	3
E	600V AC	3

Code	Interface Module
1	Standard

Code	Enclosure
N	IP20 NEMA / Open

Code	Amps	Frame	ND		HD	
			HP	kW	HP	kW
1P6 <sup>(1)</sup>	1.6	A	0.25	0.2	0.25	0.2
2P5	2.5	A	0.5	0.4	0.5	0.4
4P8	4.8	B	1.0	0.75	1.0	0.75
6P0	6.0	B	1.5	1.1	1.5	1.1

Code	Amps	Frame	ND		HD	
			HP	kW	HP	kW
1P4	1.4	A	0.5	0.4	0.5	0.4
2P3	2.3	A	1.0	0.75	1.0	0.75
4P0	4.0	A	2.0	1.5	2.0	1.5
6P0	6.0	A	3.0	2.2	3.0	2.2
010	10.5	B	5.0	4.0	5.0	4.0
013	13.0	C	7.5	5.5	7.5	5.5
017	17.0	C	10.0	7.5	10.0	7.5
024	24.0	D	15.0	11.0	15.0	11.0
030 <sup>(2)</sup>	30.0	D	20.0	15.0	15.0	11.0
037 <sup>(2)</sup>	37.0	E	25.0	18.5	20.0	15.0
043 <sup>(2)</sup>	43.0	E	30.0	22.0	25.0	18.5

Code	Amps	Frame	ND		HD	
			HP	kW	HP	kW
1P6 <sup>(1)</sup>	1.6	A	0.25	0.2	0.25	0.2
2P5	2.5	A	0.5	0.4	0.5	0.4
4P8	4.8	A	1.0	0.75	1.0	0.75
8P0	8.0	B	2.0	1.5	2.0	1.5
011	11.0	B	3.0	2.2	3.0	2.2

Code	Amps	Frame	ND		HD	
			HP	kW	HP	kW
0P9	0.9	A	0.5	0.4	0.5	0.4
1P7	1.7	A	1.0	0.75	1.0	0.75
3P0	3.0	A	2.0	1.5	2.0	1.5
4P2	4.2	A	3.0	2.2	3.0	2.2
6P6	6.6	B	5.0	4.0	5.0	4.0
9P9	9.9	C	7.5	5.5	7.5	5.5
012	12.0	C	10.0	7.5	10.0	7.5
019	19.0	D	15.0	11.0	15.0	11.0
022 <sup>(2)</sup>	22.0	D	20.0	15.0	15.0	11.0
027 <sup>(2)</sup>	27.0	E	25.0	18.5	20.0	15.0
032 <sup>(2)</sup>	32.0	E	30.0	22.0	25.0	18.5

Code	Amps	Frame	ND		HD	
			HP	kW	HP	kW
1P6 <sup>(1)</sup>	1.6	A	0.25	0.2	0.25	0.2
2P5	2.5	A	0.5	0.4	0.5	0.4
5P0	5.0	A	1.0	0.75	1.0	0.75
8P0	8.0	A	2.0	1.5	2.0	1.5
011	11.0	A	3.0	2.2	3.0	2.2
017	17.5	B	5.0	4.0	5.0	4.0
024	24.0	C	7.5	5.5	7.5	5.5
032	32.2	D	10.0	7.5	10.0	7.5
048 <sup>(2)</sup>	48.3	E	15.0	11.0	10.0	7.5
062 <sup>(2)</sup>	62.1	E	20.0	15.0	15.0	11.0

(1) This rating is only available for PowerFlex 523 drives.  
 (2)  Normal and Heavy Duty ratings are available for this drive.

## Technical Specifications

### Protection

Specifications	PowerFlex 523	PowerFlex 525
Bus Overvoltage Trip 100...120V AC Input: 200...240V AC Input: 380...480V AC Input: 525...600V AC Input:	405V DC bus (equivalent to 150V AC incoming line) 405V DC bus (equivalent to 290V AC incoming line) 810V DC bus (equivalent to 575V AC incoming line) 1005V DC bus (equivalent to 711V AC incoming line)	
Bus Undervoltage Trip 100...120V AC Input: 200...240V AC Input: 380...480V AC Input: 525...600V AC Input PO38 = 3 "600V": PO38 = 2 "480V":	190V DC bus (equivalent to 75V AC incoming line) 190V DC bus (equivalent to 150V AC incoming line) 390V DC bus (equivalent to 275V AC incoming line)  487V DC bus (equivalent to 344V AC incoming line) 390V DC bus (equivalent to 275V AC incoming line)	
Power Ride-through:	100 ms	
Logic Control Ride-through:	0.5 s min, 2 s typical	
Electronic Motor Overload Protection:	Provides class 10 motor overload protection according to NEC article 430 and motor over-temperature protection according to NEC article 430.126 (A) (2). UL 508C File 29572.	
Overcurrent:	200% hardware limit, 300% instantaneous fault	
Ground Fault Trip:	Phase-to-ground on drive output	
Short Circuit Trip:	Phase-to-phase on drive output	

### Electrical

Specifications	PowerFlex 523	PowerFlex 525
Voltage Tolerance:	-15% / +10%	
Frequency Tolerance:	47...63 Hz	
Input Phases:	Three-phase input provides full rating. Single-phase input provides 35% rating on three-phase drives.	
Displacement Power Factor:	0.98 across entire speed range	
Short Circuit Rating, max:	100,000 Amps Symmetrical	
Actual Short Circuit Rating:	Determined by AIC Rating of installed fuse/circuit breaker	
Transistor Type:	Insulated gate bipolar transistor (IGBT)	
Internal DC Bus Choke 200...240V AC Input: 380...480V AC Input: 525...600V AC Input:	Only for Frame E drive ratings 11 kW (15 HP) 15...18.5 kW (20...25 HP) – Heavy Duty 15...18.5 kW (20...25 HP) – Heavy Duty	

### Control

Specifications	PowerFlex 523	PowerFlex 525
Method	Sinusoidal PWM, Volts/Hertz, Sensorless Vector Control, Economizer SVC motor control, Closed Loop Velocity Vector Control, Surface Mount and Interior Permanent Magnet Motor (without encoder), Interior Permanent Magnet Motor (with encoder) (Closed Loop Velocity Vector Control and PM motor control are not applicable to PowerFlex 523 drives)	
Carrier Frequency	2...16 kHz, Drive rating based on 4 kHz	
Frequency Accuracy Digital Input: Analog Input: Analog Output:	Within ±0.05% of set output frequency Within 0.5% of max output frequency, 10-bit resolution ±2% of full scale, 10-Bit resolution	
Performance VHz (Volts per Hertz): SVC (Sensorless Vector): SVC Economizer:	±1% of base speed across a 60:1 speed range ±0.5% of base speed across a 100:1 speed range ±0.5% of base speed across a 100:1 speed range	
VVC (Velocity Vector Control): PM Motor <sup>(1)</sup> :	(Applicable to PowerFlex 525 drives only) ±0.5% of base speed across a 60:1 speed range ±0.5% of base speed, up to a 20:1 speed range	

## Control (Continued)

Specifications	PowerFlex 523	PowerFlex 525
Performance with Encoder SVC (Sensorless Vector): SVC Economizer: VVC (Velocity Vector Control): PM Motor (iPM motor, 10 HP rating and below) <sup>(1)</sup> :	(Applicable to PowerFlex 525 drives only) ±0.1% of base speed across a 100:1 speed range <sup>(2)</sup> ±0.1% of base speed across a 100:1 speed range <sup>(2)</sup> ±0.1% of base speed across a 1000:1 speed range <sup>(2)</sup> ±0.1% of base speed, up to a 60:1 speed range	
Output Voltage Range:	OV to rated motor voltage	
Output Frequency Range:	0...500 Hz (programmable)	
Efficiency:	97.5% (typical)	
Stop Modes:	Multiple programmable stop modes including - Ramp, Coast, DC-Brake, and Ramp to Stop	
Accel/Decel:	Four independently programmable accel and decel times. Each time can be programmed from 0...600 s in 0.01 s increments	
Intermittent Overload Normal Duty:	110% Overload capability for up to 60 s, 150% for up to 3 s Applies for power ratings above 15 kW (20 HP) only. Based on 480V drive rating	
Heavy Duty:	150% Overload capability for up to 60 s, 180% for up to 3 s (200% programmable)	

(1) For details on specific motor performance, see [rok.auto/knowledgebase](http://rok.auto/knowledgebase) answer ID [QA34823](#).

(2) For more information, see the PowerFlex 520-series Adjustable Frequency AC Drive User Manual, publication [520-UM001](#).

## Control Inputs

Specifications	PowerFlex 523	PowerFlex 525	
Digital	Bandwidth:	10 Rad/s for open and closed loop	
	Quantity:	(1) Dedicated for stop (4) Programmable	(1) Dedicated for stop (6) Programmable
	Current:	6 mA	
	Type Source Mode (SRC): Sink Mode (SNK):	18...24V = ON, 0...6V = OFF 0...6V = ON, 18...24V = OFF	
	Pulse Train Quantity: Input Signal: Input Frequency: Current Consumption:	(1) Shared with one of the programmable digital input terminals. Transistor contact (open collector) 0...100 kHz 7 mA @ 24V DC max	
Analog	Quantity:	(1) Isolated, 0...10V and 4...20 mA	(2) Isolated, -10...+10V and 4...20 mA
	Specification Resolution: 0...10V DC Analog: 4...20 mA Analog: External Pot:	10-bit 100 kΩ input impedance 250 Ω input impedance 1...10 kΩ, 2 W min	

## Control Outputs

Specifications	PowerFlex 523	PowerFlex 525	
Relay	Quantity:	1 programmable Form C	2, 1 programmable Form A and 1 programmable Form B
	Specification Resistive Rating: Inductive Rating:	3.0 A @ 30V DC, 3.0 A @ 125V, 3.0 A @ 240V AC 0.5 A @ 30V DC, 0.5 A @ 125V, 0.5 A @ 240V AC	
Opto	Quantity:	—	2, programmable
	Specification:		30V DC, 50 mA Non-inductive
Analog	Quantity:	1, nonisolated 0...10V or 4...20 mA <sup>(1)</sup>	
	Specification Resolution: 0...10V DC Analog: 4...20 mA Analog:	10-bit 1 kΩ min 525 Ω max	

(1) The feature is not applicable to PowerFlex 523 series A drives.













Encoder

Specifications	PowerFlex 523	PowerFlex 525
Type:	-	Incremental, dual channel
Supply:		12V, 250 mA
Quadrature:		90°, ±27° @ 25 °C (77 °F)
Duty Cycle:		50%, +10%
Requirements:	Encoders must be line driver type, quadrature (dual channel), or pulse (single channel), 3.5...26V DC output, single-ended or differential and capable of supplying a min of 10 mA per channel. Allowable input is DC up to a max frequency of 250 kHz. The encoder I/O automatically scales to allow 5V, 12V, and 24V DC nom voltages.	

Environmental Specifications

Specifications	PowerFlex 523	PowerFlex 525			
Altitude Without derating: With derating:	See <a href="#">Current Derating Curves on page 17</a> for derating guidelines. 1000 m (3300 ft) max Up to 4000 m (13,200 ft) max, except for 600V drives at 2000 m (6600 ft) max				
Surrounding Air Temperature, max Without derating: With derating:	See <a href="#">Current Derating Curves on page 17</a> for derating guidelines. -20...+50 °C (-4...+122 °F) -20...+60 °C (-4...+140 °F) or -20...+70 °C (-4...+158 °F) with the optional Control Module Fan kit.				
Storage Temperature Frame A...D: Frame E:	-40...+85 °C (-40...+185 °F) -40...+70 °C (-40...+158 °F)				
Atmosphere:	<b>IMPORTANT</b> Drive <b>must not</b> be installed in an area where the ambient atmosphere contains volatile or corrosive gases, vapors, or dust. If the drive is not going to be installed for a period of time, it must be stored in an area where it will not be exposed to a corrosive atmosphere.				
Relative Humidity:	0...95% noncondensing				
Shock: Vibration:	Complies with IEC 60068-2-27 Complies with IEC 60068-2-6:1995				
	<b>Frame Size</b>	<b>Operating and Nonoperating</b>		<b>Nonoperating (Transportation)</b>	
		<b>Force (Shock/Vibration)</b>	<b>Mounting Type</b>	<b>Force (Shock/Vibration)</b>	<b>Mounting Type</b>
	A	15 g / 2 g	DIN rail or screw	30 g/ 2.5 g	Screw only
	B	15 g / 2 g	DIN rail or screw	30 g/ 2.5 g	Screw only
	C	15 g / 2 g	DIN rail or screw	30 g/ 2.5 g	Screw only
	D	15 g / 2 g	Screw only	30 g/ 2.5 g	Screw only
E	15 g / 1.5 g	Screw only	30 g/ 2.5 g	Screw only	
Conformal Coating:	Complies with: IEC 60721-3-3 to level 3C2 (chemical and gases only)				
Surrounding Environment Pollution Degree Pollution Degree 1 & 2:	All enclosures are acceptable.				
Sound Pressure Level (A-weighted), max Frame A and B: Frame C: Frame D: Frame E:	Measurements are taken 1 m (3.3 ft) from the drive. 53 dBA 57 dBA 64 dBA 68 dBA				

## Certifications

Certification	PowerFlex 523	PowerFlex 525
<b>c-UL-us</b> 	Listed to UL 508C and CSA C22.2 No. 274 Listed to UL 61800-5-1 and CSA 22.2 No. 274-17	
<b>RCM</b> 	Australian Communications and Media Authority In conformity with the following: Radiocommunications Act: 1992 (including amendments up to 2018) Radiocommunications Standard: 2017 Radiocommunications Labeling Notice: 2017 Standards applied: EN 61800-3	
<b>CE</b> 	In conformity with the following European Directives: 2014/35/EU Low Voltage Directive (LVD) 2014/30/EU EMC Directive (EMC) 2014/34/EU ATEX Directive (ATEX) 2006/42/EC Machinery Directive (MD) 2011/65/EU RoHS Directive (RoHS) Standards applied: EN 61800-3 EN 61800-5-1	
<b>UKCA</b> 	In conformity with the following UK Regulations: 2016 No. 1101 Electrical Equipment (Safety) Regulations (LV) 2016 No. 1091 Electromagnetic Compatibility Regulations (EMC) 2016 No. 1107 Equipment and Protective Systems Intended for Use in Potentially Explosive Atmospheres Regulations (Ex) 2008 No. 1597 Supply of Machinery (Safety) Regulations (MD) 2012 No. 3032 Restriction of the Use of Certain Hazardous Substances in Electrical and Electronic Equipment Regulations (RoHS) 2021 No. 745 Ecodesign for Energy-Related Products and Energy Information Regulations (Eco) Standards applied: EN 61800-3 EN 61800-5-1	
<b>Functional Safety</b> 	(Applicable to PowerFlex 525 drives only) TÜV Rheinland Standards applied: EN ISO 13849-1 EN 61800-5-2 EN 61508 PARTS 1-7 EN 62061 EN 60204-1 Certified to ISO 13849-1 SIL2/PLd with embedded Safe Torque Off function Meets Functional Safety (FS) when used with embedded Safe Torque Off function	
<b>ATEX</b>  <b>TÜV 12 ATEX 7199 X</b> <b>TÜV 21 UKEX 7031 X</b>	(Applicable to PowerFlex 525 drives only) Certified to ATEX Directive 2014/34/EU Group II Category (2) GD Applications with ATEX Approved Motors Certified to UK Equipment and Protective Systems Intended for Use in Potentially Explosive Atmospheres Regulations (2016 No. 1107) Group II Category (2) GD Applications with ATEX Approved Motors	
<b>KCC</b> 	Korean Registration of Broadcasting and Communications Equipment Compliant with the following standards: Article 58-2 of Radio Waves Act, Clause 3	
<b>Efficiency Class</b> 	Ecodesign regulation (EU) 2019/1781, IE2 efficiency class, see the PowerFlex AC Drive Performance Specifications per Ecodesign Regulation (EU) 2019/1781 and UK SI 2021 No. 745 Technical Data, publication <a href="#">PFLEX-TD003</a> for additional information.	
<b>AC 156</b> 	Tested by Trentec to be compliant with AC156 Acceptance Criteria for Seismic Qualification Testing of Nonstructural Components and 2003 International Building Code for worst-case seismic level for USA excluding site class F	
<b>SEMI F47</b> 	Certified compliant with the following standards: SEMI F47 IEC 61000-4-11 IEC 61000-4-34	
<b>Lloyds Register</b> 	(Applicable to PowerFlex 525 drives only) Lloyd's Register Type Approval Certificate 12/10068(E1)	
<b>RoHS</b> 	Compliant with the European "Restriction of Hazardous Substances" 2011/65/EU Directive	

The drive is also designed to meet the appropriate portions of the following specifications:

NFPA 70 - US National Electrical Code

NEMA ICS 7.1 - Safety standards for Construction and Guide for Selection, Installation, and Operation of Adjustable Speed Drive Systems.

# Product Selection

## Catalog Number Description

<b>25B</b>	-	<b>V</b>	<b>2P5</b>	<b>N</b>	<b>1</b>	<b>0</b>	<b>4</b>
Drive		Voltage Rating	Rating	Enclosure	HIM	Emission Class	Version

## PowerFlex 520-series Drive Ratings

PowerFlex 523 Catalog Number	PowerFlex 525 Catalog Number	Output Ratings				Output Current (A)	Input Voltage Range	Total Watts Loss	Frame Size
		Normal Duty		Heavy Duty					
		HP	kW	HP	kW				
<b>100...120V AC (-15%, +10%) - 1-phase Input, 0...230V 3-phase Output</b>									
25A-V1P6N104	-	0.25	0.2	0.25	0.2	1.6	85...132	20.0	A
25A-V2P5N104	25B-V2P5N104	0.5	0.4	0.5	0.4	2.5	85...132	27.0	A
25A-V4P8N104	25B-V4P8N104	1.0	0.75	1.0	0.75	4.8	85...132	53.0	B
25A-V6P0N104	25B-V6P0N104	1.5	1.1	1.5	1.1	6.0	85...132	67.0	B
<b>200...240V AC (-15%, +10%) - 1-phase Input, 0...230V 3-phase Output</b>									
25A-A1P6N104	-	0.25	0.2	0.25	0.2	1.6	85...132	20.0	A
25A-A2P5N104	25B-A2P5N104	0.5	0.4	0.5	0.4	2.5	170...264	29.0	A
25A-A4P8N104	25B-A4P8N104	1.0	0.75	1.0	0.75	4.8	170...264	50.0	A
25A-A8P0N104	25B-A8P0N104	2.0	1.5	2.0	1.5	8.0	170...264	81.0	B
25A-A011N104	25B-A011N104	3.0	2.2	3.0	2.2	11.0	170...264	111.0	B
<b>200...240V AC (-15%, +10%) - 1-phase Input with EMC Filter, 0...230V 3-phase Output</b>									
25A-A1P6N114	-	0.25	0.2	0.25	0.2	1.6	85...132	20.0	A
25A-A2P5N114	25B-A2P5N114	0.5	0.4	0.5	0.4	2.5	170...264	29.0	A
25A-A4P8N114	25B-A4P8N114	1.0	0.75	1.0	0.75	4.8	170...264	53.0	A
25A-A8P0N114	25B-A8P0N114	2.0	1.5	2.0	1.5	8.0	170...264	84.0	B
25A-A011N114	25B-A011N114	3.0	2.2	3.0	2.2	11.0	170...264	116.0	B
<b>200...240V AC (-15%, +10%) - 3-phase Input, 0...230V 3-phase Output</b>									
25A-B1P6N104	-	0.25	0.2	0.25	0.2	1.6	85...132	20.0	A
25A-B2P5N104	25B-B2P5N104	0.5	0.4	0.5	0.4	2.5	170...264	29.0	A
25A-B5P0N104	25B-B5P0N104	1.0	0.75	1.0	0.75	5.0	170...264	50.0	A
25A-B8P0N104	25B-B8P0N104	2.0	1.5	2.0	1.5	8.0	170...264	79.0	A
25A-B011N104	25B-B011N104	3.0	2.2	3.0	2.2	11.0	170...264	107.0	A
25A-B017N104	25B-B017N104	5.0	4.0	5.0	4.0	17.5	170...264	148.0	B
25A-B024N104	25B-B024N104	7.5	5.5	7.5	5.5	24.0	170...264	259.0	C
25A-B032N104	25B-B032N104	10.0	7.5	10.0	7.5	32.2	170...264	323.0	D
25A-B048N104	25B-B048N104	15.0	11.0	10.0	7.5	48.3	170...264	584.0	E
25A-B062N104	25B-B062N104	20.0	15.0	15.0	11.0	62.1	170...264	708.0	E
<b>380...480V AC (-15%, +10%) - 3-phase Input, 0...460V 3-phase Output<sup>(1)</sup></b>									
25A-D1P4N104	25B-D1P4N104	0.5	0.4	0.5	0.4	1.4	323...528	27.0	A
25A-D2P3N104	25B-D2P3N104	1.0	0.75	1.0	0.75	2.3	323...528	37.0	A
25A-D4P0N104	25B-D4P0N104	2.0	1.5	2.0	1.5	4.0	323...528	62.0	A
25A-D6P0N104	25B-D6P0N104	3.0	2.2	3.0	2.2	6.0	323...528	86.0	A
25A-D010N104	25B-D010N104	5.0	4.0	5.0	4.0	10.5	323...528	129.0	B
25A-D013N104	25B-D013N104	7.5	5.5	7.5	5.5	13.0	323...528	170.0	C
25A-D017N104	25B-D017N104	10.0	7.5	10.0	7.5	17.0	323...528	221.0	C
25A-D024N104	25B-D024N104	15.0	11.0	15.0	11.0	24.0	323...528	303.0	D
25A-D030N104	25B-D030N104	20.0	15.0	15.0	11.0	30.0	323...528	387.0	D
<b>380...480V AC (-15%, +10%) - 3-phase Input with EMC Filter, 0...460V 3-phase Output</b>									
25A-D1P4N114	25B-D1P4N114	0.5	0.4	0.5	0.4	1.4	323...528	27.0	A
25A-D2P3N114	25B-D2P3N114	1.0	0.75	1.0	0.75	2.3	323...528	37.0	A
25A-D4P0N114	25B-D4P0N114	2.0	1.5	2.0	1.5	4.0	323...528	63.0	A

**PowerFlex 520-series Drive Ratings (Continued)**

PowerFlex 523	PowerFlex 525	Output Ratings				Input Voltage Range	Total Watts Loss	Frame Size	
		Normal Duty		Heavy Duty					Output Current (A)
Catalog Number	Catalog Number	HP	kW	HP	kW				
25A-D6P0N1T4	25B-D6P0N1T4	3.0	2.2	3.0	2.2	6.0	323...528	88.0	A
25A-D010N1T4	25B-D010N1T4	5.0	4.0	5.0	4.0	10.5	323...528	133.0	B
25A-D013N1T4	25B-D013N1T4	7.5	5.5	7.5	5.5	13.0	323...528	175.0	C
25A-D017N1T4	25B-D017N1T4	10.0	7.5	10.0	7.5	17.0	323...528	230.0	C
25A-D024N1T4	25B-D024N1T4	15.0	11.0	15.0	11.0	24.0	323...528	313.0	D
25A-D030N1T4	25B-D030N1T4	20.0	15.0	15.0	11.0	30.0	323...528	402.0	D
25A-D037N1T4	25B-D037N1T4	25.0	18.5	20.0	15.0	37.0	323...528	602.0	E
25A-D043N1T4	25B-D043N1T4	30.0	22.0	25.0	18.5	43.0	323...528	697.0	E

**525...600V AC (-15%, +10%) - 3-phase Input, 0...575V 3-phase Output**

25A-E0P9N104	25B-E0P9N104	0.5	0.4	0.5	0.4	0.9	446...660	22.0	A
25A-E1P7N104	25B-E1P7N104	1.0	0.75	1.0	0.75	1.7	446...660	32.0	A
25A-E3P0N104	25B-E3P0N104	2.0	1.5	2.0	1.5	3.0	446...660	50.0	A
25A-E4P2N104	25B-E4P2N104	3.0	2.2	3.0	2.2	4.2	446...660	65.0	A
25A-E6P6N104	25B-E6P6N104	5.0	4.0	5.0	4.0	6.6	446...660	95.0	B
25A-E9P9N104	25B-E9P9N104	7.5	5.5	7.5	5.5	9.9	446...660	138.0	C
25A-E012N104	25B-E012N104	10.0	7.5	10.0	7.5	12.0	446...660	164.0	C
25A-E019N104	25B-E019N104	15.0	11.0	15.0	11.0	19.0	446...660	290.0	D
25A-E022N104	25B-E022N104	20.0	15.0	15.0	11.0	22.0	446...660	336.0	D
25A-E027N104	25B-E027N104	25.0	18.5	20.0	15.0	27.0	446...660	466.0	E
25A-E032N104	25B-E032N104	30.0	22.0	25.0	18.5	32.0	446...660	562.0	E

(1) A non-filtered drive is not available for 380...480V AC 25 HP (18.5 kW) and 30 HP (22.0 kW) ratings. Filtered drives are available, however you must verify that the application supports a filtered drive

**Drive Dimensions and Weight**

Dimensions are in mm and (in.). Weights are in kg and (lb).

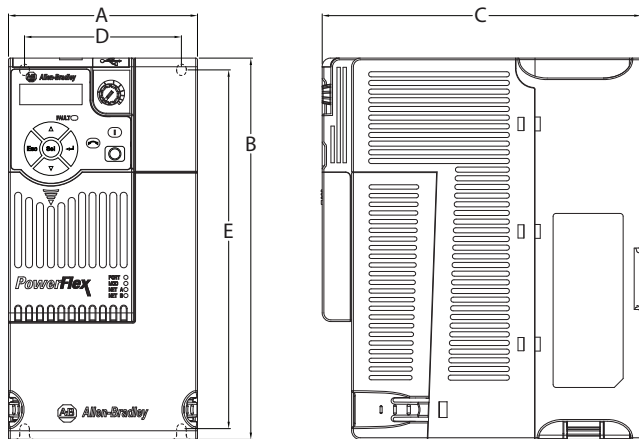

Frame Size	Dimensions					Weight
	A	B	C	D	E	
A	72.0 (2.83)	152.0 (5.98)	172.0 (6.77)	57.5 (2.26)	140.0 (5.51)	1.1 (2.4)
B	87.0 (3.43)	180.0 (7.09)	172.0 (6.77)	72.5 (2.85)	168.0 (6.61)	1.6 (3.5)
C	109.0 (4.29)	220.0 (8.66)	184.0 (7.24)	90.5 (3.56)	207.0 (8.15)	2.3 (5.0)
D	130.0 (5.12)	260.0 (10.24)	212.0 (8.35)	116.0 (4.57)	247.0 (9.72)	3.9 (8.6)
E	185.0 (7.28)	300.0 (11.81)	279.0 (10.98)	160.0 (6.30)	280.0 (11.02)	12.9 (28.4)

# Design Considerations

## Mounting Considerations

- Mount the drive upright on a flat, vertical, and level surface.

Frame	Screw Size	Screw Torque
A	M5 (#10...24)	1.56...1.96 N•m (14...17 lb•in)
B	M5 (#10...24)	1.56...1.96 N•m (14...17 lb•in)
C	M5 (#10...24)	1.56...1.96 N•m (14...17 lb•in)
D	M5 (#10...24)	2.45...2.94 N•m (22...26 lb•in)
E	M8 (5/16 in.)	6.0...7.4 N•m (53...65 lb•in)

- Protect the cooling fan by avoiding dust or metallic particles.
- Do not expose to a corrosive atmosphere.
- Protect from moisture and direct sunlight.

## Minimum Mounting Clearances

See [Product Selection on page 14](#) for mounting dimensions.

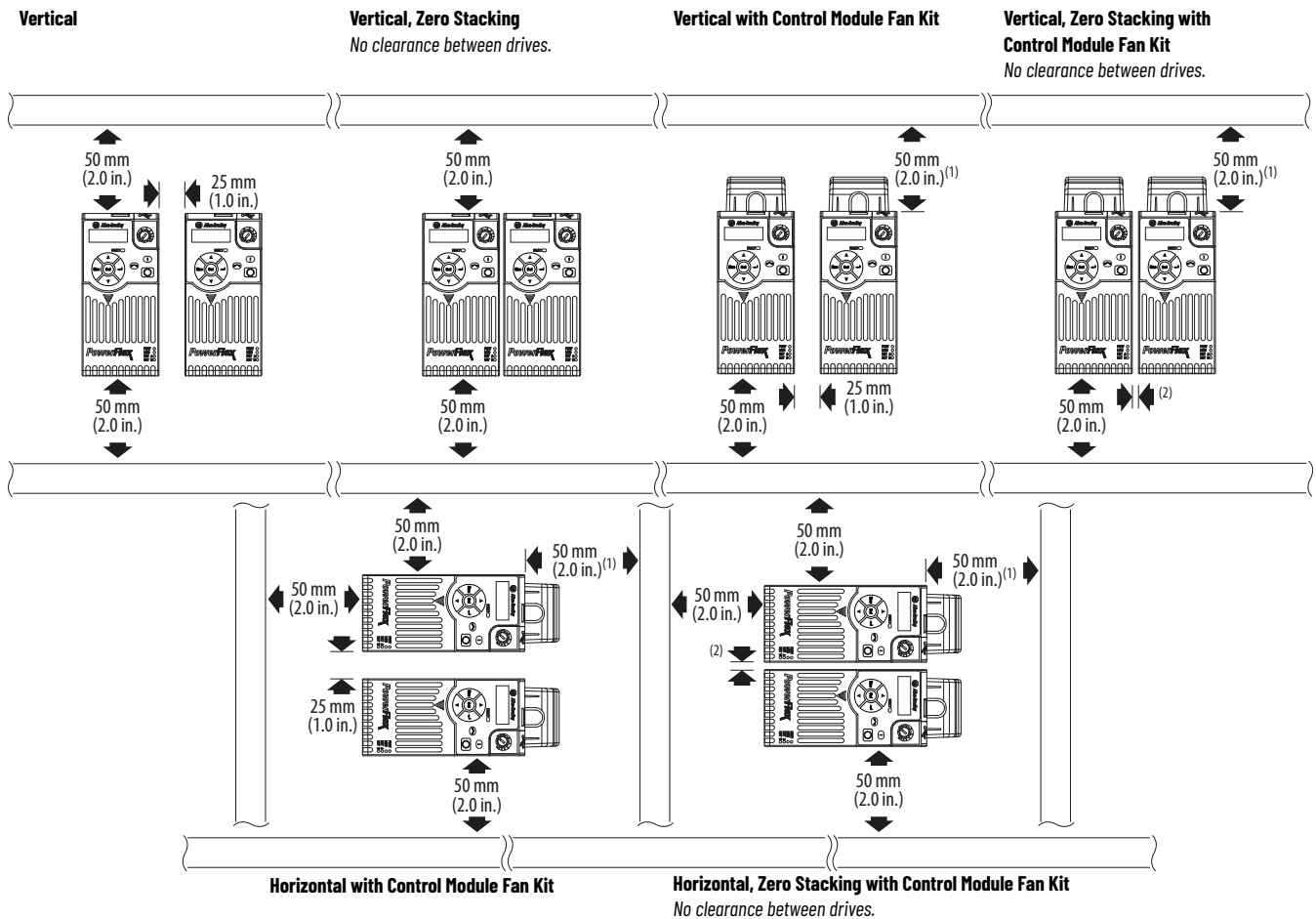

(1) For Frame E with Control Module Fan Kit only, clearance of 95 mm (3.7 in.) is required.  
 (2) For Frame E with Control Module Fan Kit only, clearance of 12 mm (0.5 in.) is required.

## Ambient Operating Temperatures

For optional accessories and kits, see [Accessories and Dimensions on page 33](#).

Mounting	Enclosure Rating <sup>(1)</sup>	Ambient Temperature			
		Min	Max (No Derate)	Max (Derate) <sup>(2)</sup>	Max with Control Module Fan Kit (Derate) <sup>(3)(4)</sup>
Vertical	IP 20/Open Type	-20 °C (-4 °F)	50 °C (122 °F)	60 °C (140 °F)	70 °C (158 °F)
	IP 30/NEMA 1/UL Type 1		45 °C (113 °F)	55 °C (131 °F)	—
Vertical, Zero Stacking	IP 20/Open Type		45 °C (113 °F)	55 °C (131 °F)	65 °C (149 °F)
	IP 30/NEMA 1/UL Type 1		40 °C (104 °F)	50 °C (122 °F)	—
Horizontal with Control Module Fan Kit <sup>(5)(4)</sup>	IP 20/Open Type		50 °C (122 °F)	—	70 °C (158 °F)
Horizontal, Zero Stacking with Control Module Fan Kit <sup>(4)(5)</sup>	IP 20/Open Type		45 °C (113 °F)	—	65 °C (149 °F)

- (1) IP 30/NEMA 1/UL Type 1 rating requires installation of the PowerFlex 520-series IP 30/NEMA 1/UL Type 1 option kit, 25-JBAX.
- (2) IP 30/NEMA 1/UL Type 1 rating requires installation of the PowerFlex 520-series IP 30/NEMA 1/UL Type 1 option kit, 25-JBAX.
- (3) For 25x-D1P4N104 and 25x-E0P9N104, the temperature that is listed under the Max with Control Module Fan Kit (Derate) column is reduced by 10 °C (18 °F) for vertical and vertical with zero stacking mounting methods only.
- (4) Requires installation of the PowerFlex 520-series Control Module Fan Kit, 25-FANx-70C.
- (5) 25x-D1P4N104 and 25x-E0P9N104 cannot be mounted using either of the horizontal mounting methods.

## Current Derating Curves

### Vertical Mounting

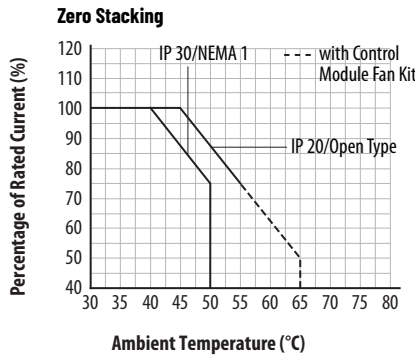
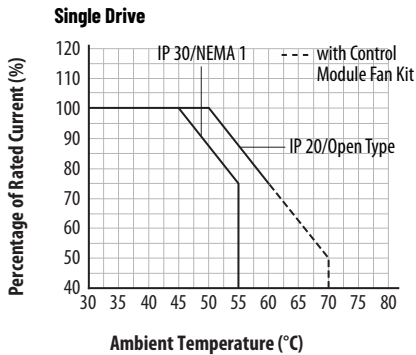

### Horizontal Mounting/Floor

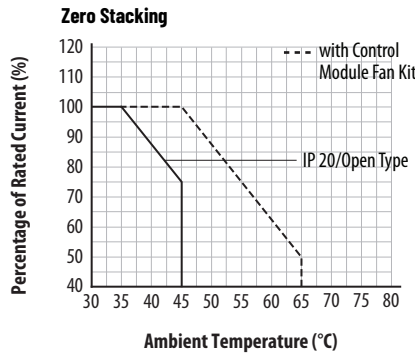
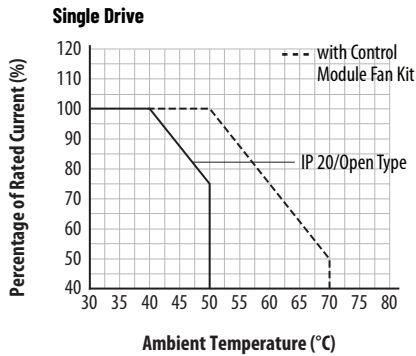

### Derating Guidelines for High Altitude

The drive can be used without derating at a maximum altitude of 1000 m (3300 ft).

If the drive is used above 1000 m (3300 ft), do one of the following:

- Derate the maximum ambient temperature by 5 °C (9 °F) for every additional 1000 m (3300 ft), subject to the limits listed in the Altitude Limit (Based on Voltage) table below.
- Derate the output current by 10% for every additional 1000 m (3300 ft), subject to the limits listed in the Altitude Limit (Based on Voltage) table below.

#### Altitude Limit (Based on Voltage)

Drive Rating	Center Ground (Wye Neutral)	Corner Ground, Impedance Ground, or Ungrounded
100...120V 1-phase	6000 m (19,685 ft)	6000 m (19,685 ft)
200...240V 1-phase	2000 m (6562 ft)	2000 m (6562 ft)
200...240V 3-phase	6000 m (19,685 ft)	2000 m (6562 ft)
380...480V 3-phase	4000 m (13,123 ft)	2000 m (6562 ft)
525...600V 3-phase	2000 m (6562 ft)	2000 m (6562 ft)

#### High Altitude

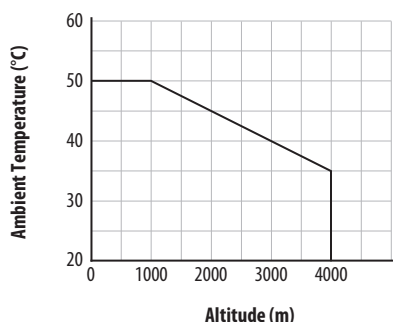
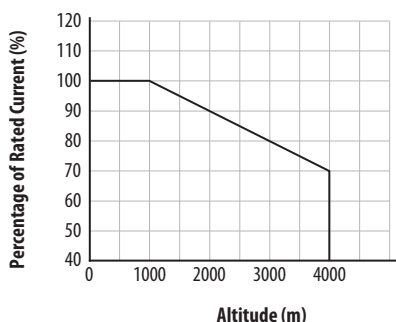

### Debris Protection

Take precautions to prevent debris from falling through the vents of the drive housing during installation.

### Storage

- Store within an ambient temperature range of -40...+85 °C (-40...+185 °F)<sup>(a)</sup>.
- Store within a relative humidity range of 0...95%, noncondensing.
- Do not expose to a corrosive atmosphere.

### AC Supply Source Considerations

#### Ungrounded Distribution Systems



**ATTENTION:** PowerFlex 520-series drives contain protective MOVs that are referenced to ground. These devices must be disconnected if the drive is installed on an ungrounded or resistive grounded distribution system.  
**ATTENTION:** Removing MOVs in drives with an embedded filter also disconnects the filter capacitor from earth ground.

(a) The maximum ambient temperature for storing a Frame E drive is 70 °C (158 °F).

### Disconnecting MOVs

To help prevent drive damage, disconnect the MOVs connected to ground if the drive is installed on an ungrounded distribution system (IT mains) where the line-to-ground voltages on any phase could exceed 125% of the nominal line-to-line voltage. To disconnect these devices, remove the jumper that is shown in the following diagrams.

1. Turn the screw counterclockwise to loosen.
2. Pull the jumper completely out of the drive chassis.
3. Tighten the screw to keep it in place.

### Jumper Location (Typical)

Power Module

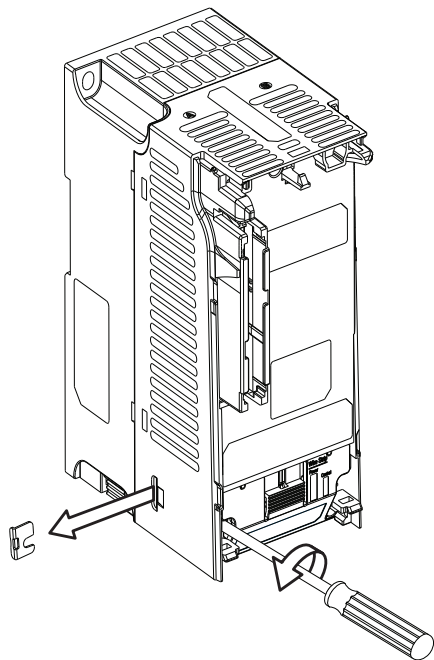



---

**IMPORTANT** Tighten screw after jumper removal.

---

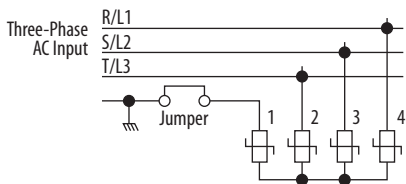
### Phase to Ground MOV Removal



### Input Power Conditioning

The drive is suitable for direct connection to input power within the rated voltage of the drive. See [Input Power Conditions on page 20](#).

Listed in the Input Power Conditions table below are certain input power conditions that can cause component damage or reduction in product life. If any of these conditions exist, install one of the devices that are listed under the heading Corrective Action on the line side of the drive.

---

**IMPORTANT** Only one device per branch circuit is required. It should be mounted closest to the branch and sized to handle the total current of the branch circuit.

---

### Input Power Conditions

Input Power Condition	Corrective Action
Low Line Impedance (less than 1% line reactance)	<ul style="list-style-type: none"> <li>• Install a Line Reactor.<sup>(1)</sup></li> <li>• Install an Isolation Transformer.</li> </ul>
Greater than 120 kVA supply transformer	
Line has power factor correction capacitors	<ul style="list-style-type: none"> <li>• Install a Line Reactor.<sup>(1)</sup></li> <li>• Install an Isolation Transformer.</li> </ul>
Line has frequent power interruptions	
Line has intermittent noise spikes in excess of 6000V (lightning)	
Phase to ground voltage exceeds 125% of normal line-to-line voltage	<ul style="list-style-type: none"> <li>• Remove the MOV jumper to ground.</li> <li>• Install an Isolation Transformer with grounded secondary if necessary.</li> </ul>
Ungrounded distribution system	
B-phase grounded distribution system	
240V open delta configuration (high leg) <sup>(2)</sup>	

(1) See [Accessories and Dimensions on page 33](#) for accessory ordering information.

(2) For drives applied on an open delta with a middle phase grounded neutral system, the phase opposite the phase that is tapped in the middle to the neutral or earth is referred to as the "stinger leg," "high leg," "red leg," and so on. This leg should be identified throughout the system with red or orange tape on the wire at each connection point. Connect the high leg to the center Phase B on the reactor. See [Bulletin 1321-3R Series Line Reactors on page 39](#) for specific line reactor part numbers.

### General Grounding Requirements

The drive safety ground - (PE) must be connected to the system ground. Ground impedance must conform to the requirements of national and local industrial safety regulations and/or electrical codes. Check the integrity of all ground connections periodically.

#### Typical Grounding

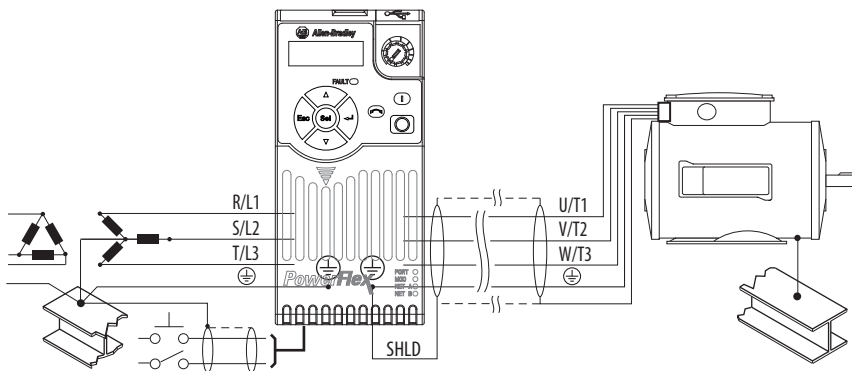

#### Ground Fault Monitoring

If a system ground fault monitor (RCD) is to be used, use only Type B (adjustable) devices to avoid nuisance tripping.

#### Safety Ground - (PE)

This is the safety ground for the drive that is required by code. One of these points must be connected to an adjacent building steel (girder, joist), a floor ground rod, or busbar. Grounding points must comply with national and local industrial safety regulations and/or electrical codes.

#### Motor Ground

The motor ground must be connected to one of the ground terminals on the drive.

## Shield Termination - SHLD

Either of the safety ground terminals that are on the power terminal block provide a grounding point for the motor cable shield. The **motor cable** shield connected to one of these terminals (drive end) should also be connected to the motor frame (motor end). Use a shield terminating or EMI clamp to connect the shield to the safety ground terminal. The earthing plate or conduit box option may be used with a cable clamp for a grounding point for the cable shield.

When a shielded cable is used for **control and signal wiring**, ground the shield at the source end only, not at the drive end.

## RFI Filter Grounding

Using a drive with a filter can result in relatively high ground leakage currents. Therefore, the **filter must only be used in installations with grounded AC supply systems and be permanently installed and solidly grounded** (bonded) to the building power distribution ground. Verify that the incoming supply neutral is solidly connected (bonded) to the same building power distribution ground. Grounding must not rely on flexible cables and should exclude any form of plug or socket that permits inadvertent disconnection. Some local codes may require redundant ground connections. The integrity of all connections should be periodically checked.

## Power Wiring



**ATTENTION:** National Codes and standards (NEC, VDE, BSI, and so on) and local codes outline provisions for safely installing electrical equipment. Installation must comply with specifications regarding wire types, conductor sizes, branch circuit protection and disconnect devices. Failure to do so may result in personal injury and/or equipment damage.

**ATTENTION:** To avoid a possible shock hazard caused by induced voltages, unused wires in the conduit must be grounded at both ends. For the same reason, if a drive sharing a conduit is being serviced or installed, all drives using this conduit should be disabled. This helps to minimize the possible shock hazard from “cross coupled” power leads.

## Motor Cable Types Acceptable for 100...600 Volt Installations

Various cable types are acceptable for drive installations. For many installations, unshielded cable is adequate, provided it can be separated from sensitive circuits. As an approximate guide, allow a spacing of 0.3 m (1 ft) for every 10 m (32.8 ft) of length. In all cases, long parallel runs must be avoided. Do not use cables with an insulation thickness less than 15 mils (0.4 mm/0.015 in.). Do not route more than three sets of motor leads in one conduit to minimize “cross talk”. If more than three drive/motor connections per conduit are required, a shielded cable must be used.

UL installations above 50 °C (122 °F) ambient must use 600V, 90 °C (122 °F) wire.

UL installations in 50 °C (122 °F) ambient must use 600V, 75 °C (167 °F) or 90 °C (194 °F) wire.

UL installations in 40 °C (104 °F) ambient must use 600V, 75 °C (167 °F) or 90 °C (194 °F) wire.

Use copper wire only. Wire gauge requirements and recommendations are based on 75 °C (167 °F). Do not reduce the wire gauge when using higher temperature wire.

## Unshielded

THHN, THWN, or similar wire is acceptable for drive installation in dry environments provided adequate free air space and/or conduit fill rates limits are provided. Any wire that is chosen must have a minimum insulation thickness of 15 mils (0.4 mm/0.015 in.) and must not have large variations in insulation concentricity.



**ATTENTION:** Do not use THHN or similarly coated wire in wet areas.

## Shielded/Armored Cable

Shielded cables contain all of the general benefits of multi-conductor cable with the added benefit of a copper braided shield that can contain much of the noise that is generated by a typical AC Drive. Consider using shielded cables in installations with sensitive equipment such as weigh scales, capacitive proximity switches, and other devices that may be affected by electrical noise in the distribution system. Applications with large numbers of drives in a similar location, imposed EMC regulations or a high degree of communications / networking are also good candidates for shielded cable.

Shielded cables can also help to reduce shaft voltage and induced bearing currents for some applications. In addition, the increased impedance of shielded cable can help to extend the distance that the motor can be located from the drive without the addition of motor protective devices such as terminator networks. See the chapter “Reflected Wave” in the Wiring and Grounding for Pulse Width Modulated (PWM) AC Drives Installation Instructions, publication [DRIVES-IN001](#).

Consideration should be given to all general specifications that are dictated by the environment of the installation, including temperature, flexibility, moisture characteristics, and chemical resistance. In addition, a braided shield should be included and be specified by the cable manufacturer as having coverage of at least 75%. An additional foil shield can greatly improve noise containment.

A good example of a recommended cable is the Belden 295xx (xx determines gauge). This cable has four XLPE insulated conductors with a 100% coverage foil and an 85% coverage copper braided shield (with drain wire) surrounded by a PVC jacket.

Other types of shielded cable are available, but the selection of these types can limit the allowable cable length. Particularly, some of the newer cables twist four conductors of THHN wire and wrap them tightly with a foil shield. This construction can greatly increase the cable charging current required and reduce the overall drive performance. Unless specified in the individual distance tables as tested with the drive, these cables are not recommended and their performance against the lead length limits supplied is not known.

### Recommended Shielded Wire

Location	Rating/Type	Description
Standard (Option 1)	600V, 90 °C (194 °F) XHHW2/RHW-2 Anixter B209500...B209507, Belden 29501...29507, or equivalent	<ul style="list-style-type: none"> <li>Four tinned copper conductors with XLPE insulation</li> <li>Copper braid/aluminum foil combination shield and tinned copper drain wire</li> <li>PVC jacket</li> </ul>
Standard (Option 2)	Tray rated 600V, 90 °C (194 °F) RHH/RHW-2 Anixter OLF-7xxxx or equivalent	<ul style="list-style-type: none"> <li>Three tinned copper conductors with XLPE insulation</li> <li>5 mil (0.127 mm/0.005 in.) single helical copper tape (25% overlap min) with three bare copper grounds in contact with shield</li> <li>PVC jacket</li> </ul>
Class I & II; Division I & II	Tray rated 600V, 90 °C (194 °F) RHH/RHW-2 Anixter 7V-7xxxx-3G or equivalent	<ul style="list-style-type: none"> <li>Three bare copper conductors with XLPE insulation and impervious corrugated continuously welded aluminum armor</li> <li>Black sunlight resistant PVC jacket overall</li> <li>Three copper grounds on 6 mm<sup>2</sup> (10 AWG) and smaller</li> </ul>

### Reflected Wave Protection

Install the drive as close to the motor as possible. Installations with long motor cables can require the addition of external devices to limit voltage reflections at the motor (reflected wave phenomena). See the chapter “Reflected Wave” in the Wiring and Grounding for Pulse Width Modulated (PWM) AC Drives Installation Instructions, publication [DRIVES-IN001](#).

The reflected wave data applies to all carrier frequencies 2...16 kHz.

For 240V ratings and lower, reflected wave effects do not need to be considered.

### Output Disconnect

The drive is intended to be commanded by control input signals that start and stop the motor. Do not use a device that routinely disconnects then reapplies output power to the motor for starting and stopping the motor. If it is necessary to disconnect power to the motor with the drive outputting power, use an auxiliary contact to disable the drive (Aux Fault or Coast-to-Stop) simultaneously.

## Power Terminal Block Wire Specifications

Frame	Wire Size Max <sup>(1)</sup>	Wire Size Min <sup>(1)</sup>	Torque
A	5.3 mm <sup>2</sup> (10 AWG)	0.8 mm <sup>2</sup> (18 AWG)	1.76...2.16 N•m (15.6...19.1 lb•in)
B	8.4 mm <sup>2</sup> (8 AWG)	2.1 mm <sup>2</sup> (14 AWG)	1.76...2.16 N•m (15.6...19.1 lb•in)
C	8.4 mm <sup>2</sup> (8 AWG)	2.1 mm <sup>2</sup> (14 AWG)	1.76...2.16 N•m (15.6...19.1 lb•in)
D	13.3 mm <sup>2</sup> (6 AWG)	5.3 mm <sup>2</sup> (10 AWG)	1.76...2.16 N•m (15.6...19.1 lb•in)
E	26.7 mm <sup>2</sup> (3 AWG)	8.4 mm <sup>2</sup> (8 AWG)	3.09...3.77 N•m (27.3...33.4 lb•in)

(1) Maximum/minimum sizes that the terminal block accepts - These are not recommendations.

## Common Bus/Precharge Notes

If drives are used with a disconnect switch to the common DC bus, then an auxiliary contact on the disconnect must be connected to a digital input of the drive.

## I/O Wiring

### Motor Start/Stop Precautions



**ATTENTION:** A contactor or other device that routinely disconnects and reapplies the AC line to the drive to start and stop the motor can cause drive hardware damage. The drive is designed to use control input signals that start and stop the motor. If used, the input device must not exceed one operation per minute, or drive damage can occur.

**ATTENTION:** The drive start/stop control circuitry includes solid-state components. If hazards due to accidental contact with moving machinery or unintentional flow of liquid, gas or solids exist, an additional hardwired stop circuit may be required to remove the AC line to the drive. When the AC line is removed, there will be a loss of any inherent regenerative braking effect that might be present - the motor will coast to a stop. An auxiliary braking method may be required. Alternatively, use the drive's safety input function.

Important points to remember about I/O wiring:

- Always use copper wire.
- Wire with an insulation rating of 600V or greater is recommended.
- Separate control and signal wires from power wires by at least 0.3 m (1 ft).

**IMPORTANT** I/O terminals labeled "Common" are not referenced to the safety ground (PE) terminal and are designed to greatly reduce common mode interference.



**ATTENTION:** Driving the 4...20 mA analog input from a voltage source could cause component damage. Verify proper configuration before applying input signals.

### Signal and Control Wire Types

Recommendations are for 50 °C (122 °F) ambient temperature.

75 °C (167 °F) wire must be used for 60 °C (140 °F) ambient temperature.

90 °C (194 °F) wire must be used for 70 °C (158 °F) ambient temperature.

## Recommended Signal Wire

Signal Type/Where Used	Belden Wire Type, or equivalent <sup>(1)</sup>	Description	Insulation Rating, Min
Analog I/O and PTC	8760/9460	0.750 mm <sup>2</sup> (18 AWG), twisted-pair, 100% shield with drain <sup>(2)</sup>	300V, 60 °C (140 °F)
Remote Pot	8770	0.750 mm <sup>2</sup> (18 AWG), 3 conductor, shielded	
Encoder/Pulse I/O	9728/9730	0.196 mm <sup>2</sup> (24 AWG), individually shielded pairs	

(1) Stranded or solid wire.

(2) If the wires are short and contained within a cabinet that has no sensitive circuits, the use of shielded wire may not be necessary, but is always recommended.

## Recommended Control Wire for Digital I/O

Type	Wire Types	Description	Insulation Rating, Min
Unshielded	Per US NEC or applicable national or local code	—	300V, 60 °C (140 °F)
Shielded	Multi-conductor shielded cable such as Belden 8770 (or equivalent)	0.750 mm <sup>2</sup> (18 AWG), 3 conductor, shielded.	

### Maximum Control Wire Recommendation

Do not exceed control wiring length of 30 m (100 ft). Control signal cable length is highly dependent on the electrical environment and installation practices. To improve noise immunity, the I/O terminal block Common can be connected to ground terminal/protective earth. If using the RS-485 (DSI) port, also connect I/O Terminal C1 to the ground terminal/protective earth. Additionally, communication noise immunity can also be improved by connecting I/O Terminal C2 to ground terminal/protective earth.

### Control I/O Terminal Block Wire Specifications

Frame	Wire Size, Max <sup>(1)</sup>	Wire Size, Min <sup>(1)</sup>	Torque
A...E	1.3 mm <sup>2</sup> (16 AWG)	0.13 mm <sup>2</sup> (26 AWG)	0.71...0.86 N•m (6.2...7.6 lb•in)

(1) Maximum/minimum sizes that the terminal block accepts – These are not recommendations.

## Machinery Directive (2006/42/EC)

- EN ISO 13849-1 – Safety of machinery – Safety related parts of control systems – Part 1: General principles for design
- EN 62061 – Safety of machinery – Functional safety of safety-related electrical, electronic, and programmable electronic control systems
- EN 60204-1 – Safety of machinery – Electrical equipment of machines – Part 1: General requirements
- EN 61800-5-2 – Adjustable speed electrical power drive systems – Part 5-2: Safety requirement – Functional

## Connections and Grounding

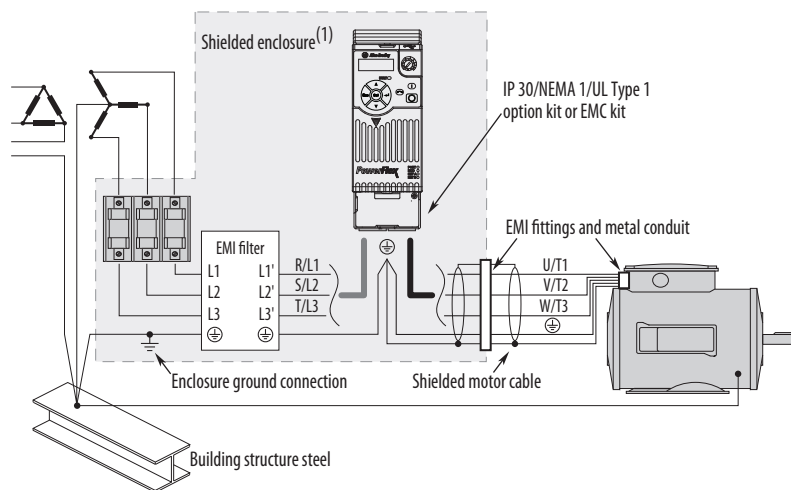

(1) Some installations require a shielded enclosure. Keep the wire length as short as possible between the enclosure entry point and the EMI filter.

## PowerFlex 520-series RF Emission Compliance and Installation Requirements

Filter Type	Standard/Limits		
	EN61800-3 Category C1 EN61000-6-3 CISPR11 Group 1 Class B	EN61800-3 Category C2 EN61000-6-4 CISPR11 Group 1 Class A (Input power ≤ 20 kVA)	EN61800-3 Category C3 (I ≤ 100 A) CISPR11 Group 1 Class A (Input power > 20 kVA)
Internal	—	10 m (33 ft)	20 m (66 ft)
External <sup>(1)</sup>	30 m (16 ft)	150 m (492 ft)	150 m (492 ft)

(1) See [EMC Line Filters on page 34](#) and [page 43](#) for more information on optional external filters.

## Fuses and Circuit Breaker Ratings

The PowerFlex 520-series drive does not provide branch short circuit protection. Install this product with either input fuses or an input circuit breaker. National and local industrial safety regulations and/or electrical codes may determine additional requirements for these installations.

The tables on pages [26...32](#) provide drive ratings and recommended AC line input fuse and circuit breaker information. Both types of short circuit protection are acceptable for UL and IEC requirements. The sizes that are listed are the recommended sizes based on 40 °C (104 °F) and the U.S. N.E.C. Other country, state, or local codes can require different ratings.

### Fusing

The recommended fuse types are listed in the tables on pages [26...32](#). If the available current ratings do not match those listed in the tables provided, choose the next higher fuse rating.

- IEC – BS88 (British Standard) Parts 1 & 2<sup>(a)</sup>, EN60269-1, Parts 1 & 2, type GG or equivalent should be used.
- UL – UL Class CC, T, RK1, or J should be used.

(a) Typical designations include, but may not be limited to the following:  
Parts 1 & 2: AC, AD, BC, BD, CD, DD, ED, EFS, EF, FF, FG, GF, GG, GH

### Circuit Breakers

The “non-fuse” listings in the tables on pages 26...32 include inverse time circuit breakers, instantaneous trip circuit breakers (motor circuit protectors) and 140M/140MT self-protected combination motor controllers. If one of these is chosen as the desired protection method, the following requirements apply:

- IEC – Both types of circuit breakers and 140M/140MT self-protected combination motor controllers are acceptable for IEC installations.
- UL – Only inverse time circuit breakers and the specified 140M/140MT self-protected combination motor controllers are acceptable for UL installations.

### Bulletin 140M/140MT (Self-protected Combination Controller)/UL489 Circuit Breakers

When using Bulletin 140M/140MT or UL489 rated circuit breakers, the following guidelines must be followed to meet the NEC requirements for branch circuit protection.

- Bulletin 140M/140MT can be used in single motor applications.
- Bulletin 140M/140MT can be used up stream from the drive **without** the need for fuses.

## Fuses and Circuit Breakers for PowerFlex 520-series Drives

### 100...120V 1-phase Input Protection Devices – Frames A...B – IEC (Non-UL) Applications

Catalog Number		Output Ratings				Input Ratings			Frame Size	Contactor Catalog Number	IEC (Non-UL) Applications			
PF 523	PF 525	ND		HD		A	kVA	Max Current A <sup>(1)</sup>			Fuses (Rating)		Circuit Breakers	
		HP	kW	HP	kW						Min	Max	140U/140UT	140M/140MT <sup>(2)(3)(4)</sup>
25A-V1P6N104	–	0.25	0.2	0.25	0.2	1.6	0.8	6.4	A	100-C09 100-E09	10	16	140U-D6D2-B80 140UT-D7D2-B80	140M-C2E-B63 140MT-C3E-B63
25A-V2P5N104	25B-V2P5N104	0.5	0.4	0.5	0.4	2.5	1.3	9.6	A	100-C12 100-E12	16	20	140U-D6D2-C12 140UT-D7D2-C12	140M-C2E-C10 140MT-C3E-C10
25A-V4P8N104	25B-V4P8N104	1.0	0.75	1.0	0.75	4.8	2.5	19.2	B	100-C23 100-E26	25	40	140U-D6D2-C25 140UT-D7D2-C25	140M-D8E-C20 140MT-D9E-C20
25A-V6P0N104	25B-V6P0N104	1.5	1.1	1.5	1.1	6.0	3.2	24.0	B	100-C23	32	50	140U-D6D2-C30 140UT-D7D2-C30	140M-F8E-C25 140MT-F9E-C25

- (1) When the drive is controlling motors with lower ampere ratings, see the drive nameplate for drive input current rating.
- (2) The AIC ratings of the Bulletin 140M/140MT devices can vary. See the Motor Protection Circuit Breaker and Motor Circuit Protector Specifications Technical Data, publication [140-TD005](#) or [140M-TD002](#).
- (3) Bulletin 140M/140MT devices with adjustable current range must have the current trip set to the minimum range that the device does not trip.
- (4) Manual Self-protected (Type E) Combination Motor Controller, UL Listed for 208V Wye or Delta, 240V Wye or Delta, 480V Y/277 or 600V Y/347. Not UL Listed for use on 480V or 600V Delta/Delta, corner ground, or high-resistance ground systems.

### 100...120V 1-phase Input Protection Devices – Frames A...B – UL 61800-5-1 Applications

Catalog Number		Output Ratings				Input Ratings			Frame Size	Contactor Catalog Number	UL 61800-5-1 Applications		
PF 523	PF 525	ND		HD		A	kVA	Max Current A <sup>(1)</sup>			Fuses (Max Rating)	Circuit Breakers	
		HP	kW	HP	kW						Class/ Catalog Number	140UT	140M/140MT <sup>(2)(3)(4)</sup>
25A-V1P6N104	–	0.25	0.2	0.25	0.2	1.6	0.8	6.4	A	100-C09 100-E09	CLASS CC, J, or T/15	140UT-D7D2-B80	140MT-C3E-B63 140MT-D9E-B63
25A-V2P5N104	25B-V2P5N104	0.5	0.4	0.5	0.4	2.5	1.3	9.6	A	100-C12 100-E12	CLASS CC, J, or T/20	140UT-D7D2-C12	140MT-C3E-C10 140MT-D9E-C10
25A-V4P8N104	25B-V4P8N104	1.0	0.75	1.0	0.75	4.8	2.5	19.2	B	100-C23 100-E26	CLASS CC, J, or T/40	— <sup>(5)</sup>	140MT-D9E-C20
25A-V6P0N104	25B-V6P0N104	1.5	1.1	1.5	1.1	6.0	3.2	24.0	B	100-C23	CLASS CC, J, or T/50	— <sup>(5)</sup>	140M-F8E-C25 140MT-F9E-C25

- (1) When the drive is controlling motors with lower ampere ratings, see the drive nameplate for drive input current rating.
- (2) The AIC ratings of the Bulletin 140M/140MT devices can vary. See the Motor Protection Circuit Breaker and Motor Circuit Protector Specifications Technical Data, publication [140-TD005](#) or [140M-TD002](#).
- (3) Bulletin 140M/140MT devices with adjustable current range must have the current trip set to the minimum range that the device does not trip.
- (4) Manual Self-protected (Type E) Combination Motor Controller, UL Listed for 208V Wye or Delta, 240V Wye or Delta, 480V Y/277 or 600V Y/347. Not UL Listed for use on 480V or 600V Delta/Delta, corner ground, or high-resistance ground systems.
- (5) Circuit breaker selection is not available for this drive rating.

## 200...240V 1-phase Input Protection Devices - Frames A...B – IEC (Non-UL) Applications

Catalog Number		Output Ratings				Input Ratings			Frame Size	Contactor Catalog Number	IEC (Non-UL) Applications			
PF 523	PF 525	ND		HD		A	kVA	Max Current A <sup>(1)</sup>			Fuses (Rating)		Circuit Breakers	
		HP	kW	HP	kW						Min	Max	140U/140UT/140G	140M/140MT <sup>(2)(3)(4)</sup>
25A-A1P6N104	—	0.25	0.2	0.25	0.2	1.6	1.4	5.3	A	100-C09 100-E09	6	10	140U-D6D2-C10 140UT-D7D2-C10	140M-C2E-B63 140MT-C3E-B63
25A-A1P6N114	—	0.25	0.2	0.25	0.2	1.6	1.4	5.3	A	100-C09 100-E09	6	10	140U-D6D2-C10 140UT-D7D2-C10	140M-C2E-B63 140MT-C3E-B63
25A-A2P5N104	25B-A2P5N104	0.5	0.4	0.5	0.4	2.5	1.7	6.5	A	100-C09 100-E09	10	16	140U-D6D2-C10 140UT-D7D2-C10	140M-C2E-C10 140MT-C3E-C10
25A-A2P5N114	25B-A2P5N114	0.5	0.4	0.5	0.4	2.5	1.7	6.5	A	100-C09 100-E09	10	16	140U-D6D2-C10 140UT-D7D2-C10	140M-C2E-C10 140MT-C3E-C10
25A-A4P8N104	25B-A4P8N104	1.0	0.75	1.0	0.75	4.8	2.8	10.7	A	100-C12 100-E12	16	25	140U-D6D2-C15 140UT-D7D2-C15	140M-C2E-C16 140MT-C3E-C16
25A-A4P8N114	25B-A4P8N114	1.0	0.75	1.0	0.75	4.8	2.8	10.7	A	100-C12 100-E12	16	25	140U-D6D2-C15 140UT-D7D2-C15	140M-C2E-C16 140MT-C3E-C16
25A-A8P0N104	25B-A8P0N104	2.0	1.5	2.0	1.5	8.0	4.8	18.0	B	100-C23	25	40	140U-D6D2-C25 140UT-D7D2-C25	140M-F8E-C25 140MT-F9E-C25
25A-A8P0N114	25B-A8P0N114	2.0	1.5	2.0	1.5	8.0	4.8	18.0	B	100-C23	25	40	140U-D6D2-C25 140UT-D7D2-C25	140M-F8E-C25 140MT-F9E-C25
25A-A011N104	25B-A011N104	3.0	2.2	3.0	2.2	11.0	6.0	22.9	B	100-C37	32	50	140G-G6C3-C35	140M-F8E-C25 140MT-F9E-C25
25A-A011N114	25B-A011N114	3.0	2.2	3.0	2.2	11.0	6.0	22.9	B	100-C37	32	50	140G-G6C3-C35	140M-F8E-C25 140MT-F9E-C25

(1) When the drive is controlling motors with lower ampere ratings, see the drive nameplate for drive input current rating.

(2) The AIC ratings of the Bulletin 140M/140MT devices can vary. See the Motor Protection Circuit Breaker and Motor Circuit Protector Specifications Technical Data, publication [140-TD005](#) or [140M-TD002](#).

(3) Bulletin 140M/140MT devices with adjustable current range must have the current trip set to the minimum range that the device does not trip.

(4) Manual Self-protected (Type E) Combination Motor Controller, UL Listed for 208V Wye or Delta, 240V Wye or Delta, 480V Y/277 or 600V Y/347. Not UL Listed for use on 480V or 600V Delta/Delta, corner ground, or high-resistance ground systems.

## 200...240V 1-phase Input Protection Devices - Frames A...B – UL 61800-5-1 Applications

Catalog Number		Output Ratings				Input Ratings			Frame Size	Contactor Catalog Number	UL 61800-5-1 Applications			
PF 523	PF 525	ND		HD		A	kVA	Max Current A <sup>(1)</sup>			Fuses (Max Rating)		Circuit Breakers	
		HP	kW	HP	kW						Class/ Catalog Number	140UT	140M/140MT <sup>(2)(3)(4)</sup>	
25A-A1P6N104	—	0.25	0.2	0.25	0.2	1.6	1.4	5.3	A	100-C09 100-E09	CLASS CC, J, or T/15	140UT-D7D2-C10	140MT-D9E-B63	
25A-A1P6N114	—	0.25	0.2	0.25	0.2	1.6	1.4	5.3	A	100-C09 100-E09	CLASS CC, J, or T/15	140UT-D7D2-C10	140MT-D9E-B63	
25A-A2P5N104	25B-A2P5N104	0.5	0.4	0.5	0.4	2.5	1.7	6.5	A	100-C09 100-E09	CLASS CC, J, or T/15	140UT-D7D2-C10	140MT-D9E-C10	
25A-A2P5N114	25B-A2P5N114	0.5	0.4	0.5	0.4	2.5	1.7	6.5	A	100-C09 100-E09	CLASS CC, J, or T/15	140UT-D7D2-C10	140MT-D9E-C10	
25A-A4P8N104	25B-A4P8N104	1.0	0.75	1.0	0.75	4.8	2.8	10.7	A	100-C12 100-E12	CLASS CC, J, or T/25	140UT-D7D2-C15	140MT-D9E-C16	
25A-A4P8N114	25B-A4P8N114	1.0	0.75	1.0	0.75	4.8	2.8	10.7	A	100-C12 100-E12	CLASS CC, J, or T/25	140UT-D7D2-C15	140MT-D9E-C16	
25A-A8P0N104	25B-A8P0N104	2.0	1.5	2.0	1.5	8.0	4.8	18.0	B	100-C23	CLASS CC, J, or T/40	— <sup>(5)</sup>	140M-F8E-C25 140MT-F9E-C25	
25A-A8P0N114	25B-A8P0N114	2.0	1.5	2.0	1.5	8.0	4.8	18.0	B	100-C23	CLASS CC, J, or T/40	— <sup>(5)</sup>	140M-F8E-C25 140MT-F9E-C25	
25A-A011N104	25B-A011N104	3.0	2.2	3.0	2.2	11.0	6.0	22.9	B	100-C37	CLASS CC, J, or T/50	— <sup>(5)</sup>	140M-F8E-C25 140MT-F9E-C25	
25A-A011N114	25B-A011N114	3.0	2.2	3.0	2.2	11.0	6.0	22.9	B	100-C37	CLASS CC, J, or T/50	— <sup>(5)</sup>	140M-F8E-C25 140MT-F9E-C25	

(1) When the drive is controlling motors with lower ampere ratings, see the drive nameplate for drive input current rating.

(2) The AIC ratings of the Bulletin 140M/140MT devices can vary. See the Motor Protection Circuit Breaker and Motor Circuit Protector Specifications Technical Data, publication [140-TD005](#) or [140M-TD002](#).

(3) Bulletin 140M/140MT devices with adjustable current range must have the current trip set to the minimum range that the device does not trip.

(4) Manual Self-protected (Type E) Combination Motor Controller, UL Listed for 208V Wye or Delta, 240V Wye or Delta, 480V Y/277 or 600V Y/347. Not UL Listed for use on 480V or 600V Delta/Delta, corner ground, or high-resistance ground systems.

(5) Circuit breaker selection is not available for this drive rating.

200...240V 3-phase Input Protection Devices – Frames A...E – IEC (Non-UL) Applications

Catalog Number <sup>(1)</sup>		Output Ratings				Input Ratings			Frame Size	Contactor Catalog Number	IEC (Non-UL) Applications			
PF 523	PF 525	ND		HD		A	kVA	Max Current A <sup>(2)</sup>			Fuses (Rating)		Circuit Breakers	
		HP	kW	HP	kW						Min	Max	140U/140UT/140G	140M/140MT <sup>(3)(4)(5)</sup>
25A-B1P6N104	—	0.25	0.2	0.25	0.2	1.6	0.9	1.9	A	100-C09 100-E09	3	6	140U-D6D3-B30 140UT-D7D3-B30	140M-C2E-B25 140MT-C3E-B25
25A-B2P5N104	25B-B2P5N104	0.5	0.4	0.5	0.4	2.5	1.2	2.7	A	100-C09 100-E09	6	6	140U-D6D3-B40 140UT-D7D3-B40	140M-C2E-B40 140MT-C3E-B40
25A-B5P0N104	25B-B5P0N104	1.0	0.75	1.0	0.75	5.0	2.7	5.8	A	100-C09 100-E09	10	16	140U-D6D3-B80 140UT-D7D3-B80	140M-C2E-B63 140MT-C3E-B63
25A-B8P0N104	25B-B8P0N104	2.0	1.5	2.0	1.5	8.0	4.3	9.5	A	100-C12 100-E12	16	20	140U-D6D3-C10 140UT-D7D3-C10	140M-C2E-C10 140MT-C3E-C10
25A-B011N104	25B-B011N104	3.0	2.2	3.0	2.2	11.0	6.3	13.8	A	100-C23 100-E26	20	32	140U-D6D3-C15 140UT-D7D3-C15	140M-C2E-C16 140MT-C3E-C16
25A-B017N104	25B-B017N104	5.0	4.0	5.0	4.0	17.5	9.6	21.1	B	100-C23	32	45	140U-D6D3-C25 140UT-D7D3-C25	140M-F8E-C25 140MT-F9E-C25
25A-B024N104	25B-B024N104	7.5	5.5	7.5	5.5	24.0	12.2	26.6	C	100-C37	35	63	140G-G6C3-C35	140M-F8E-C32 140MT-F9E-C32
25A-B032N104	25B-B032N104	10.0	7.5	10.0	7.5	32.2	15.9	34.8	D	100-C43	45	70	140G-G6C3-C60	140M-F8E-C45 140MT-F9E-C45
25A-B048N104	25B-B048N104	15.0	11.0	10.0	7.5	48.3	20.1	44.0	E	100-C60	63	90	140G-G6C3-C70	140M-F8E-C45 140MT-F9E-C45
25A-B062N104	25B-B062N104	20.0	15.0	15.0	11.0	62.1	25.6	56.0	E	100-C72 100-E65	70	125	140G-G6C3-C90	_(6)

- (1)   Normal and Heavy Duty ratings are available for this drive.
- (2) When the drive is controlling motors with lower ampere ratings, see the drive nameplate for drive input current rating.
- (3) The AIC ratings of the Bulletin 140M/140MT devices can vary. See the Motor Protection Circuit Breaker and Motor Circuit Protector Specifications Technical Data, publication [140-TD005](#) or [140M-TD002](#).
- (4) Bulletin 140M/140MT devices with adjustable current range must have the current trip set to the minimum range that the device does not trip.
- (5) Manual Self-protected (Type E) Combination Motor Controller, UL Listed for 208V Wye or Delta, 240V Wye or Delta, 480V Y/277 or 600V Y/347. Not UL Listed for use on 480V or 600V Delta/Delta, corner ground, or high-resistance ground systems.
- (6) Circuit breaker selection is not available for this drive rating.

200...240V 3-phase Input Protection Devices – Frames A...E – UL 61800-5-1 Applications

Catalog Number <sup>(1)</sup>		Output Ratings				Input Ratings			Frame Size	Contactor Catalog Number	UL 61800-5-1 Applications		
PF 523	PF 525	ND		HD		A	kVA	Max Current A <sup>(2)</sup>			Fuses (Max Rating)	Circuit Breakers	
		HP	kW	HP	kW						Class/ Catalog Number	140UT	140M/140MT <sup>(3)(4)(5)</sup>
25A-B1P6N104	—	0.25	0.2	0.25	0.2	1.6	0.9	1.9	A	100-C09 100-E09	CLASS CC, J, or T/6	140UT-D7D3-B30	140MT-D9E-B25
25A-B2P5N104	25B-B2P5N104	0.5	0.4	0.5	0.4	2.5	1.2	2.7	A	100-C09 100-E09	CLASS CC, J, or T/6	140UT-D7D3-B40	140MT-D9E-B40
25A-B5P0N104	25B-B5P0N104	1.0	0.75	1.0	0.75	5.0	2.7	5.8	A	100-C09 100-E09	CLASS CC, J, or T/15	140UT-D7D3-B80	140MT-D9E-B63
25A-B8P0N104	25B-B8P0N104	2.0	1.5	2.0	1.5	8.0	4.3	9.5	A	100-C12 100-E12	CLASS CC, J, or T/20	140UT-D7D3-C10	140MT-D9E-C10
25A-B011N104	25B-B011N104	3.0	2.2	3.0	2.2	11.0	6.3	13.8	A	100-C23 100-E26	CLASS CC, J, or T/30	140UT-D7D3-C15	140MT-D9E-C16
25A-B017N104	25B-B017N104	5.0	4.0	5.0	4.0	17.5	9.6	21.1	B	100-C23	CLASS CC, J, or T/45	140UT-D7D3-C25	140M-F8E-C25 140MT-F9E-C25
25A-B024N104	25B-B024N104	7.5	5.5	7.5	5.5	24.0	12.2	26.6	C	100-C37	CLASS CC, J, or T/60	_(6)	140M-F8E-C32 140MT-F9E-C32
25A-B032N104	25B-B032N104	10.0	7.5	10.0	7.5	32.2	15.9	34.8	D	100-C43	CLASS CC, J, or T/70	_(6)	140M-F8E-C45 140MT-F9E-C45
25A-B048N104	25B-B048N104	15.0	11.0	10.0	7.5	48.3	20.1	44.0	E	100-C60	CLASS CC, J, or T/90	_(6)	140M-F8E-C45 140MT-F9E-C45
25A-B062N104	25B-B062N104	20.0	15.0	15.0	11.0	62.1	25.6	56.0	E	100-C72 100-E65	CLASS CC, J, or T/125	_(6)	_(6)

- (1)   Normal and Heavy Duty ratings are available for this drive.
- (2) When the drive is controlling motors with lower ampere ratings, see the drive nameplate for drive input current rating.
- (3) The AIC ratings of the Bulletin 140M/140MT devices can vary. See the Motor Protection Circuit Breaker and Motor Circuit Protector Specifications Technical Data, publication [140-TD005](#) or [140M-TD002](#).

- (4) Bulletin 140M/140MT devices with adjustable current range must have the current trip set to the minimum range that the device does not trip.
- (5) Manual Self-protected (Type E) Combination Motor Controller, UL Listed for 208V Wye or Delta, 240V Wye or Delta, 480V Y/277 or 600V Y/347. Not UL Listed for use on 480V or 600V Delta/ Delta, corner ground, or high-resistance ground systems.
- (6) Circuit breaker selection is not available for this drive rating.

### 380...480V 3-phase Input Protection Devices – Frames A...E – IEC (Non-UL) Applications

Catalog Number <sup>(1)</sup>		Output Ratings				Input Ratings			Frame Size	Contactor Catalog Number	IEC (Non-UL) Applications			
PF 523	PF 525	ND		HD		A	kVA	Max Current A <sup>(2)</sup>			Fuses (Rating)		Circuit Breakers	
		HP	kW	HP	kW						Min	Max	140U/140UT/140G	140M/140MT <sup>(3)(4)(5)</sup>
25A-D1P4N104	25B-D1P4N104	0.5	0.4	0.5	0.4	1.4	1.7	1.9	A	100-C09 100-E09	3	6	140U-D6D3-B30 140UT-D7D3-B30	140M-C2E-B25 140MT-C3E-B25
25A-D1P4N114	25B-D1P4N114	0.5	0.4	0.5	0.4	1.4	1.7	1.9	A	100-C09 100-E09	3	6	140U-D6D3-B30 140UT-D7D3-B30	140M-C2E-B25 140MT-C3E-B25
25A-D2P3N104	25B-D2P3N104	1.0	0.75	1.0	0.75	2.3	2.9	3.2	A	100-C09 100-E09	6	10	140U-D6D3-B60 140UT-D7D3-B60	140M-C2E-B40 140MT-C3E-B40
25A-D2P3N114	25B-D2P3N114	1.0	0.75	1.0	0.75	2.3	2.9	3.2	A	100-C09 100-E09	6	10	140U-D6D3-B60 140UT-D7D3-B60	140M-C2E-B40 140MT-C3E-B40
25A-D4P0N104	25B-D4P0N104	2.0	1.5	2.0	1.5	4.0	5.2	5.7	A	100-C09 100-E09	10	16	140U-D6D3-B60 140UT-D7D3-B60	140M-C2E-B63 140MT-C3E-B63
25A-D4P0N114	25B-D4P0N114	2.0	1.5	2.0	1.5	4.0	5.2	5.7	A	100-C09 100-E09	10	16	140U-D6D3-B60 140UT-D7D3-B60	140M-C2E-B63 140MT-C3E-B63
25A-D6P0N104	25B-D6P0N104	3.0	2.2	3.0	2.2	6.0	6.9	7.5	A	100-C09 100-E09	10	16	140U-D6D3-C10 140UT-D7D3-C10	140M-C2E-C10 140MT-C3E-C10
25A-D6P0N114	25B-D6P0N114	3.0	2.2	3.0	2.2	6.0	6.9	7.5	A	100-C09 100-E09	10	16	140U-D6D3-C10 140UT-D7D3-C10	140M-C2E-C10 140MT-C3E-C10
25A-D010N104	25B-D010N104	5.0	4.0	5.0	4.0	10.5	12.6	13.8	B	100-C23 100-E26	20	32	140U-D6D3-C15 140UT-D7D3-C15	140M-C2E-C16 140MT-D9E-C16
25A-D010N114	25B-D010N114	5.0	4.0	5.0	4.0	10.5	12.6	13.8	B	100-C23 100-E26	20	32	140U-D6D3-C15 140UT-D7D3-C15	140M-C2E-C16 140MT-D9E-C16
25A-D013N104	25B-D013N104	7.5	5.5	7.5	5.5	13.0	14.1	15.4	C	100-C23 100-E26	20	35	140U-D6D3-C25 140UT-D7D3-C25	140M-D8E-C20 140MT-D9E-C20
25A-D013N114	25B-D013N114	7.5	5.5	7.5	5.5	13.0	14.1	15.4	C	100-C23 100-E26	20	35	140U-D6D3-C25 140UT-D7D3-C25	140M-D8E-C20 140MT-D9E-C20
25A-D017N104	25B-D017N104	10.0	7.5	10.0	7.5	17.0	16.8	18.4	C	100-C23 100-E26	25	40	140U-D6D3-C25 140UT-D7D3-C25	140M-D8E-C20 140MT-D9E-C20
25A-D017N114	25B-D017N114	10.0	7.5	10.0	7.5	17.0	16.8	18.4	C	100-C23 100-E26	25	40	140U-D6D3-C25 140UT-D7D3-C25	140M-D8E-C20 140MT-D9E-C20
25A-D024N104	25B-D024N104	15.0	11.0	15.0	11.0	24.0	24.1	26.4	D	100-C37	35	63	140G-G6C3-C40	140M-F8E-C32 140MT-F9E-C32
25A-D024N114	25B-D024N114	15.0	11.0	15.0	11.0	24.0	24.1	26.4	D	100-C37	35	63	140G-G6C3-C40	140M-F8E-C32 140MT-F9E-C32
25A-D030N104	25B-D030N104	20.0	15.0	15.0	11.0	30.0	30.2	33.0	D	100-C43	45	70	140G-G6C3-C50	140M-F8E-C45 140MT-F9E-C45
25A-D030N114	25B-D030N114	20.0	15.0	15.0	11.0	30.0	30.2	33.0	D	100-C43	45	70	140G-G6C3-C50	140M-F8E-C45 140MT-F9E-C45
25A-D037N114	25B-D037N114	25.0	18.5	20.0	15.0	37.0	30.8	33.7	E	100-C43	45	70	140G-G6C3-C50	140M-F8E-C45 140MT-F9E-C45
25A-D043N114	25B-D043N114	30.0	22.0	25.0	18.5	43.0	35.6	38.9	E	100-C60	50	80	140G-G6C3-C60	140M-F8E-C45 140MT-F9E-C45

- (1)   Normal and Heavy Duty ratings are available for this drive.
- (2) When the drive is controlling motors with lower ampere ratings, see the drive nameplate for drive input current rating.
- (3) The AIC ratings of the Bulletin 140M/140MT devices can vary. See the Motor Protection Circuit Breaker and Motor Circuit Protector Specifications Technical Data, publication [140-TD005](#) or [140M-TD002](#).
- (4) Bulletin 140M/140MT devices with adjustable current range must have the current trip set to the minimum range that the device does not trip.
- (5) Manual Self-protected (Type E) Combination Motor Controller, UL Listed for 208V Wye or Delta, 240V Wye or Delta, 480V Y/277 or 600V Y/347. Not UL Listed for use on 480V or 600V Delta/ Delta, corner ground, or high-resistance ground systems.

380...480V 3-phase Input Protection Devices – Frames A...E – UL 61800-5-1 Applications

Catalog Number <sup>(1)</sup>		Output Ratings				Input Ratings			Frame Size	Contactor Catalog Number	UL 61800-5-1 Applications		
PF 523	PF 525	ND		HD		A	kVA	Max Current A <sup>(2)</sup>			Fuses (Max Rating)	Circuit Breakers	
		HP	kW	HP	kW						Class/ Catalog Number	140UT	140M/140MT <sup>(3)(4)(5)</sup>
25A-D1P4N104	25B-D1P4N104	0.5	0.4	0.5	0.4	1.4	1.7	1.9	A	100-C09 100-E09	CLASS CC, J, or T/6	— <sup>(6)</sup>	140MT-C3E-B25
25A-D1P4N114	25B-D1P4N114	0.5	0.4	0.5	0.4	1.4	1.7	1.9	A	100-C09 100-E09	CLASS CC, J, or T/6	— <sup>(6)</sup>	140MT-C3E-B25
25A-D2P3N104	25B-D2P3N104	1.0	0.75	1.0	0.75	2.3	2.9	3.2	A	100-C09 100-E09	CLASS CC, J, or T/10	— <sup>(6)</sup>	140MT-C3E-B40
25A-D2P3N114	25B-D2P3N114	1.0	0.75	1.0	0.75	2.3	2.9	3.2	A	100-C09 100-E09	CLASS CC, J, or T/10	— <sup>(6)</sup>	140MT-C3E-B40
25A-D4P0N104	25B-D4P0N104	2.0	1.5	2.0	1.5	4.0	5.2	5.7	A	100-C09 100-E09	CLASS CC, J, or T/15	— <sup>(6)</sup>	140MT-C3E-B63
25A-D4P0N114	25B-D4P0N114	2.0	1.5	2.0	1.5	4.0	5.2	5.7	A	100-C09 100-E09	CLASS CC, J, or T/15	— <sup>(6)</sup>	140MT-C3E-B63
25A-D6P0N104	25B-D6P0N104	3.0	2.2	3.0	2.2	6.0	6.9	7.5	A	100-C09 100-E09	CLASS CC, J, or T/15	— <sup>(6)</sup>	140MT-C3E-C10
25A-D6P0N114	25B-D6P0N114	3.0	2.2	3.0	2.2	6.0	6.9	7.5	A	100-C09 100-E09	CLASS CC, J, or T/15	— <sup>(6)</sup>	140MT-C3E-C10
25A-D010N104	25B-D010N104	5.0	4.0	5.0	4.0	10.5	12.6	13.8	B	100-C23 100-E26	CLASS CC, J, or T/30	— <sup>(6)</sup>	140MT-D9E-C16
25A-D010N114	25B-D010N114	5.0	4.0	5.0	4.0	10.5	12.6	13.8	B	100-C23 100-E26	CLASS CC, J, or T/30	— <sup>(6)</sup>	140MT-D9E-C16
25A-D013N104	25B-D013N104	7.5	5.5	7.5	5.5	13.0	14.1	15.4	C	100-C23 100-E26	CLASS CC, J, or T/35	— <sup>(6)</sup>	140MT-D9E-C20
25A-D013N114	25B-D013N114	7.5	5.5	7.5	5.5	13.0	14.1	15.4	C	100-C23 100-E26	CLASS CC, J, or T/35	— <sup>(6)</sup>	140MT-D9E-C20
25A-D017N104	25B-D017N104	10.0	7.5	10.0	7.5	17.0	16.8	18.4	C	100-C23 100-E26	CLASS CC, J, or T/40	— <sup>(6)</sup>	140MT-D9E-C20
25A-D017N114	25B-D017N114	10.0	7.5	10.0	7.5	17.0	16.8	18.4	C	100-C23 100-E26	CLASS CC, J, or T/40	— <sup>(6)</sup>	140MT-D9E-C20
25A-D024N104	25B-D024N104	15.0	11.0	15.0	11.0	24.0	24.1	26.4	D	100-C37	CLASS CC, J, or T/60	— <sup>(6)</sup>	140M-F8E-C32 140MT-F9E-C32
25A-D024N114	25B-D024N114	15.0	11.0	15.0	11.0	24.0	24.1	26.4	D	100-C37	CLASS CC, J, or T/60	— <sup>(6)</sup>	140M-F8E-C32 140MT-F9E-C32
25A-D030N104	25B-D030N104	20.0	15.0	15.0	11.0	30.0	30.2	33.0	D	100-C43	CLASS CC, J, or T/70	— <sup>(6)</sup>	140M-F8E-C45 140MT-F9E-C45
25A-D030N114	25B-D030N114	20.0	15.0	15.0	11.0	30.0	30.2	33.0	D	100-C43	CLASS CC, J, or T/70	— <sup>(6)</sup>	140M-F8E-C45 140MT-F9E-C45
25A-D037N114	25B-D037N114	25.0	18.5	20.0	15.0	37.0	30.8	33.7	E	100-C43	CLASS CC, J, or T/70	— <sup>(6)</sup>	140M-F8E-C45 140MT-F9E-C45
25A-D043N114	25B-D043N114	30.0	22.0	25.0	18.5	43.0	35.6	38.9	E	100-C60	CLASS CC, J, or T/80	— <sup>(6)</sup>	140M-F8E-C45 140MT-F9E-C45

- (1) ■ Normal and Heavy Duty ratings are available for this drive.
- (2) When the drive is controlling motors with lower ampere ratings, see the drive nameplate for drive input current rating.
- (3) The AIC ratings of the Bulletin 140M/140MT devices can vary. See the Motor Protection Circuit Breaker and Motor Circuit Protector Specifications Technical Data, publication [140-TD005](#) or [140M-TD002](#).
- (4) Bulletin 140M/140MT devices with adjustable current range must have the current trip set to the minimum range that the device does not trip.
- (5) Manual Self-protected (Type E) Combination Motor Controller, UL Listed for 208V Wye or Delta, 240V Wye or Delta, 480V Y/277 or 600V Y/347. Not UL Listed for use on 480V or 600V Delta/ Delta, corner ground, or high-resistance ground systems.
- (6) Circuit breaker selection is not available for this drive rating.

## 525...600V 3-Phase Input Protection Devices – Frames A...E – IEC (Non-UL) Applications

Catalog Number <sup>(1)</sup>		Output Ratings				Input Ratings			Frame Size	Contactor Catalog Number	IEC (Non-UL) Applications			
PF 523	PF 525	ND		HD		A	kVA	Max Current A <sup>(2)</sup>			Fuses (Rating)		Circuit Breakers	
		HP	kW	HP	kW						Min	Max	140U/140UT/140G	140M/140MT <sup>(3)(4)(5)</sup>
25A-E0P9N104	25B-E0P9N104	0.5	0.4	0.5	0.4	0.9	1.4	1.2	A	100-C09 100-E09	3	6	140U-D6D3-B20 140UT-D7D3-B20	140M-C2E-B25 140MT-C3E-B25
25A-E1P7N104	25B-E1P7N104	1.0	0.75	1.0	0.75	1.7	2.6	2.3	A	100-C09 100-E09	3	6	140U-D6D3-B30 140UT-D7D3-B30	140M-C2E-B25 140MT-C3E-B25
25A-E3P0N104	25B-E3P0N104	2.0	1.5	2.0	1.5	3.0	4.3	3.8	A	100-C09 100-E09	6	10	140U-D6D3-B50 140UT-D7D3-B50	140M-C2E-B40 140MT-C3E-B40
25A-E4P2N104	25B-E4P2N104	3.0	2.2	3.0	2.2	4.2	6.1	5.3	A	100-C09 100-E09	10	16	140U-D6D3-B80 140UT-D7D3-B80	140M-C2E-B63 140MT-D9E-B63
25A-E6P6N104	25B-E6P6N104	5.0	4.0	5.0	4.0	6.6	9.1	8.0	B	100-C09 100-E09	10	20	140U-D6D3-C10 140UT-D7D3-C10	140M-C2E-C10 140MT-D9E-C10
25A-E9P9N104	25B-E9P9N104	7.5	5.5	7.5	5.5	9.9	12.8	11.2	C	100-C16 100-E16	16	25	140U-D6D3-C15 140UT-D7D3-C15	140M-C2E-C16 140MT-D9E-C16
25A-E012N104	25B-E012N104	10.0	7.5	10.0	7.5	12.0	15.4	13.5	C	100-C23 100-E26	20	32	—	140M-C2E-C16 140MT-D9E-C16
25A-E019N104	25B-E019N104	15.0	11.0	15.0	11.0	19.0	27.4	24.0	D	100-C30	32	50	140G-G6C3-C30	140M-F8E-C25 140MT-F9E-C25
25A-E022N104	25B-E022N104	20.0	15.0	15.0	11.0	22.0	31.2	27.3	D	100-C30	35	63	140G-G6C3-C35	140M-F8E-C32 140MT-F9E-C32
25A-E027N104	25B-E027N104	25.0	18.5	20.0	15.0	27.0	28.2	24.7	E	100-C30	35	50	140G-G6C3-C35	140M-F8E-C32 140MT-F9E-C32
25A-E032N104	25B-E032N104	30.0	22.0	25.0	18.5	32.0	33.4	29.2	E	100-C37	40	63	140G-G6C3-C50	140M-F8E-C32 140MT-F9E-C32

(1) ■ Normal and Heavy Duty ratings are available for this drive.

(2) When the drive is controlling motors with lower ampere ratings, see the drive nameplate for drive input current rating.

(3) The AIC ratings of the Bulletin 140M/140MT devices can vary. See the Motor Protection Circuit Breaker and Motor Circuit Protector Specifications Technical Data, publication [140-TD005](#) or [140M-TD002](#).

(4) Bulletin 140M/140MT devices with adjustable current range must have the current trip set to the minimum range that the device does not trip.

(5) Manual Self-protected (Type E) Combination Motor Controller, UL Listed for 208V Wye or Delta, 240V Wye or Delta, 480V Y/277 or 600V Y/347. Not UL Listed for use on 480V or 600V Delta/Delta, corner ground, or high-resistance ground systems.

525...600V 3-phase Input Protection Devices – Frames A...E – UL 61800-5-1 Applications

Catalog Number <sup>(1)</sup>		Output Ratings				Input Ratings			Frame Size	Contactor Catalog Number	UL 61800-5-1 Applications		
PF 523	PF 525	ND		HD		A	kVA	Max Current A <sup>(2)</sup>			Fuses (Max Rating)	Circuit Breakers	
		HP	kW	HP	kW						Class/ Catalog Number	14OUT	140M/140MT <sup>(3)(4)(5)</sup>
25A-E0P9N104	25B-E0P9N104	0.5	0.4	0.5	0.4	0.9	1.4	1.2	A	100-C09 100-E09	CLASS CC, J, or T/6	_(6)	140MT-C3E-B25
25A-E1P7N104	25B-E1P7N104	1.0	0.75	1.0	0.75	1.7	2.6	2.3	A	100-C09 100-E09	CLASS CC, J, or T/6	_(6)	140MT-C3E-B25
25A-E3P0N104	25B-E3P0N104	2.0	1.5	2.0	1.5	3.0	4.3	3.8	A	100-C09 100-E09	CLASS CC, J, or T/10	_(6)	140MT-C3E-B40
25A-E4P2N104	25B-E4P2N104	3.0	2.2	3.0	2.2	4.2	6.1	5.3	A	100-C09 100-E09	CLASS CC, J, or T/15	_(6)	140MT-D9E-B63
25A-E6P6N104	25B-E6P6N104	5.0	4.0	5.0	4.0	6.6	9.1	8.0	B	100-C09 100-E09	CLASS CC, J, or T/20	_(6)	140MT-D9E-C10
25A-E9P9N104	25B-E9P9N104	7.5	5.5	7.5	5.5	9.9	12.8	11.2	C	100-C16 100-E16	CLASS CC, J, or T/25	_(6)	140MT-D9E-C16
25A-E012N104	25B-E012N104	10.0	7.5	10.0	7.5	12.0	15.4	13.5	C	100-C23 100-E26	CLASS CC, J, or T/30	_(6)	140MT-D9E-C16
25A-E019N104	25B-E019N104	15.0	11.0	15.0	11.0	19.0	27.4	24.0	D	100-C30	CLASS CC, J, or T/50	_(6)	140M-F8E-C25 140MT-F9E-C25
25A-E022N104	25B-E022N104	20.0	15.0	15.0	11.0	22.0	31.2	27.3	D	100-C30	CLASS CC, J, or T/60	_(6)	140M-F8E-C32 140MT-F9E-C32
25A-E027N104	25B-E027N104	25.0	18.5	20.0	15.0	27.0	28.2	24.7	E	100-C30	CLASS CC, J, or T/50	_(6)	140M-F8E-C32 140MT-F9E-C32
25A-E032N104	25B-E032N104	30.0	22.0	25.0	18.5	32.0	33.4	29.2	E	100-C37	CLASS CC, J, or T/60	_(6)	140M-F8E-C32 140MT-F9E-C32

- (1) ■ Normal and Heavy Duty ratings are available for this drive.
- (2) When the drive is controlling motors with lower ampere ratings, see the drive nameplate for drive input current rating.
- (3) The AIC ratings of the Bulletin 140M/140MT devices can vary. See the Motor Protection Circuit Breaker and Motor Circuit Protector Specifications Technical Data, publication [140-TD005](#) or [140M-TD002](#).
- (4) Bulletin 140M/140MT devices with adjustable current range must have the current trip set to the minimum range that the device does not trip.
- (5) Manual Self-protected (Type E) Combination Motor Controller, UL Listed for 208V Wye or Delta, 240V Wye or Delta, 480V Y/277 or 600V Y/347. Not UL Listed for use on 480V or 600V Delta/ Delta, corner ground, or high-resistance ground systems.
- (6) Circuit breaker selection is not available for this drive rating.

## Accessories and Dimensions

### Dynamic Brake Resistors

Drive Ratings			Minimum Resistance $\Omega \pm 10\%$	Resistance $\Omega \pm 5\%$	Catalog Number <sup>(1)(2)</sup>	Fuse Protection <sup>(3)</sup>		
Input Voltage	HP	kW				BR- <sup>(4)</sup>	DC+/BR+	DC-
100...120V 50/60 Hz 1-phase	0.25	0.2	56	91	AK-R2-091P500	PV-15A10F	1000GH-016	1000GH-016
	0.5	0.4	56	91	AK-R2-091P500	PV-15A10F	1000GH-016	1000GH-016
	1.0	0.75	56	91	AK-R2-091P500	PV-15A10F	1000GH-016	1000GH-016
	1.5	1.1	41	91	AK-R2-091P500	PV-15A10F	1000GH-020	1000GH-020
200...240V 50/60 Hz 1-phase	0.25	0.2	56	91	AK-R2-091P500	PV-15A10F	1000GH-016	1000GH-016
	0.5	0.4	56	91	AK-R2-091P500	PV-15A10F	1000GH-016	1000GH-016
	1.0	0.75	56	91	AK-R2-091P500	PV-15A10F	1000GH-016	1000GH-016
	2.0	1.5	41	91	AK-R2-091P500	PV-32ANH1	1000GH-025	1000GH-025
	3.0	2.2	32	47	AK-R2-047P500	PV-32ANH1	1000GH-032	1000GH-032
200...240V 50/60 Hz 3-phase	0.25	0.2	56	91	AK-R2-091P500	PV-20A10F	1000GH-016	1000GH-016
	0.5	0.4	56	91	AK-R2-091P500	PV-20A10F	1000GH-016	1000GH-016
	1.0	0.75	56	91	AK-R2-091P500	PV-20A10F	1000GH-016	1000GH-016
	2.0	1.5	41	91	AK-R2-091P500	PV-20A10F	1000GH-025	1000GH-025
	3.0	2.2	32	47	AK-R2-047P500	PV-20A10F	1000GH-032	1000GH-032
	5.0	4.0	18	47	AK-R2-047P500	PV-32ANH1	1000GH-050	1000GH-050
	7.5	5.5	16	30	AK-R2-030P1K2	PV-40ANH1	1000GH-063	1000GH-063
	10.0	7.5	14	30	AK-R2-030P1K2	1000GH-040	1000GH-080	1000GH-080
	15.0	11.0	14	15	AK-R2-030P1K2 <sup>(5)</sup>	1000GH-050	1000GH-100	1000GH-100
	20.0	15.0	10	15	AK-R2-030P1K2 <sup>(5)</sup>	1000GH-050	1000GH-125	1000GH-125
380...480V 50/60 Hz 3-phase	0.5	0.4	89	360	AK-R2-360P500	PV-10A10F	1000GH-016	1000GH-016
	1.0	0.75	89	360	AK-R2-360P500	PV-10A10F	1000GH-016	1000GH-016
	2.0	1.5	89	360	AK-R2-360P500	PV-10A10F	1000GH-016	1000GH-016
	3.0	2.2	89	120	AK-R2-120P1K2	PV-10A10F	1000GH-016	1000GH-016
	5.0	4.0	47	120	AK-R2-120P1K2	PV-20A10F	1000GH-032	1000GH-032
	7.5	5.5	47	120	AK-R2-120P1K2	PV-32ANH1	1000GH-032	1000GH-032
	10.0	7.5	47	120	AK-R2-120P1K2	PV-32ANH1	1000GH-040	1000GH-040
	15.0	11.0	43	60	AK-R2-120P1K2 <sup>(5)</sup>	1000GH-025	1000GH-063	1000GH-063
	20.0	15.0	43	60	AK-R2-120P1K2 <sup>(5)</sup>	1000GH-025	1000GH-080	1000GH-080
	25.0	18.5	27	40	AK-R2-120P1K2 <sup>(6)</sup>	1000GH-040	1000GH-080	1000GH-080
	30.0	22.0	27	40	AK-R2-120P1K2 <sup>(6)</sup>	1000GH-040	1000GH-080	1000GH-080
525...600V 50/60 Hz 3-phase	0.5	0.4	112	360	AK-R2-360P500	PV-10A10F	1000GH-016	1000GH-016
	1.0	0.75	112	360	AK-R2-360P500	PV-10A10F	1000GH-016	1000GH-016
	2.0	1.5	112	360	AK-R2-360P500	PV-10A10F	1000GH-016	1000GH-016
	3.0	2.2	112	120	AK-R2-120P1K2	PV-10A10F	1000GH-016	1000GH-016
	5.0	4.0	86	120	AK-R2-120P1K2	PV-12A10F	1000GH-025	1000GH-025
	7.5	5.5	59	120	AK-R2-120P1K2	PV-20A10F	1000GH-025	1000GH-025
	10.0	7.5	59	120	AK-R2-120P1K2	PV-20A10F	1000GH-032	1000GH-032
	15.0	11.0	59	60	AK-R2-120P1K2 <sup>(5)</sup>	1000GH-025	1000GH-050	1000GH-050
	20.0	15.0	59	60	AK-R2-120P1K2 <sup>(5)</sup>	1000GH-025	1000GH-063	1000GH-063
	25.0	18.5	53	60	AK-R2-120P1K2 <sup>(5)</sup>	1000GH-040	1000GH-063	1000GH-063
	30.0	22.0	34	40	AK-R2-120P1K2 <sup>(6)</sup>	1000GH-040	1000GH-063	1000GH-063

(1) The resistors that are listed in this tables are rated for 5% duty cycle.

(2) Use of Rockwell Automation resistors is always recommended. The resistors that are listed have been carefully selected to optimize performance in various applications. Alternative resistors can be used, however, care must be taken when making a selection. See the PowerFlex Dynamic Braking Resistor Calculator Application Technique, publication [PFLEX-AT001](#).

(3) For IEC applications, DC Fuse is mandatory when these terminals are connected. Connect the fuse to the terminal. Use the specified part number. PV-xxxxx fuse is from Bussman. 1000GH-xxx fuse is from Hinode.

(4) For UL applications, a DC fuse is mandatory at the BR- terminal when used with a dynamic brake resistor.

(5) Requires two resistors that are wired in parallel.

(6) Requires three resistors that are wired in parallel.

EMC Line Filters

Short-circuit Current Rating (SCCR) = 100 kA						
Drive Ratings				Frame Size	For 100 m (328 ft) Catalog Number	For 150 m (492 ft) <sup>(1)</sup> Catalog Number
Input Voltage	HP	kW	Current (A)			
100...120V 50/60 Hz 1-phase	0.25	0.2	1.6	A	25-RF011-AL	—
	0.5	0.4	2.5	A	25-RF011-AL	—
	1.0	0.75	4.8	B	25-RF023-BL	—
	1.5	1.1	6.0	B	25-RF023-BL	—
200...240V 50/60 Hz 1-phase	0.25	0.2	1.6	A	25-RF011-AL	
	0.5	0.4	2.5	A	25-RF011-AL	
	1.0	0.75	4.8	A	25-RF011-AL	
	2.0	1.5	8.0	B	25-RF023-BL	
	3.0	2.2	11.0	B	25-RF023-BL	
200...240V 50/60 Hz 3-phase	0.25	0.2	1.6	A	25-RF014-AL	25-RF021-BL
	0.5	0.4	2.5	A	25-RF014-AL	25-RF021-BL
	1.0	0.75	5.0	A	25-RF014-AL	25-RF021-BL
	2.0	1.5	8.0	A	25-RF014-AL	25-RF021-BL
	3.0	2.2	11.0	A	25-RF014-AL	25-RF021-BL
	5.0	4.0	17.5	B	25-RF021-BL	
	7.5	5.5	24.0	C	25-RF027-CL	
	10.0	7.5	32.2	D	25-RF035-DL	
	15.0	11.0	48.3	E	25-RF056-EL	
	20.0	15.0	62.1	E	25-RF056-EL	
380...480V 50/60 Hz 3-phase	0.5	0.4	1.4	A	25-RF7P5-AL	25-RF014-BL
	1.0	0.75	2.3	A	25-RF7P5-AL	25-RF014-BL
	2.0	1.5	4.0	A	25-RF7P5-AL	25-RF014-BL
	3.0	2.2	6.0	A	25-RF7P5-AL	25-RF014-BL
	5.0	4.0	10.5	B	25-RF014-BL	
	7.5	5.5	13.0	C	25-RF018-CL	
	10.0	7.5	17.0	C	25-RF018-CL	
	15.0	11.0	24.0	D	25-RF033-DL	
	20.0	15.0	30.0	D	25-RF033-DL	
	25.0	18.5	37.0	E	25-RF039-EL	
	30.0	22.0	43.0	E	25-RF039-EL	
525...600V 50/60 Hz 3-phase	0.5	0.4	0.9	A	25-RF8P0-BL <sup>(2)</sup>	—
	1.0	0.75	1.7	A	25-RF8P0-BL <sup>(2)</sup>	—
	2.0	1.5	3.0	A	25-RF8P0-BL <sup>(2)</sup>	—
	3.0	2.2	4.2	A	25-RF8P0-BL <sup>(2)</sup>	—
	5.0	4.0	6.6	B	25-RF8P0-BL	—
	7.5	5.5	9.9	C	25-RF014-CL	—
	10.0	7.5	12.0	C	25-RF014-CL	—
	15.0	11.0	19.0	D	25-RF027-DL	—
	20.0	15.0	22.0	D	25-RF027-DL	—
	25.0	18.5	27.0	E	25-RF029-EL	—
	30.0	22.0	32.0	E	25-RF029-EL <sup>(2)</sup>	—

(1) Requires series B filters to achieve a 150 m (492 ft) rating.  
 (2) The 600V drive rating must be matched with a frame B line filter.

## EMC Plates

Item	Description	Frame Size	Catalog Number
EMC Plate	Optional grounding plate for shielded cables	A	25-EMC1-FA
		B	25-EMC1-FB
		C	25-EMC1-FC
		D	25-EMC1-FD
		E	25-EMC1-FE

## EMC Ferrite Cores

Item	Description	Frame Size	Catalog Number
EMC Ferrite Core	For drive with internal filter	A	25-CORE-A
		B	25-CORE-B
		C	25-CORE-C
		D	25-CORE-D
		E	25-CORE-E
	For drive with external filter	A	25-CORE-RF-A
		B	25-CORE-RF-B
		C	25-CORE-RF-C
		D	25-CORE-RF-D
		E	25-CORE-RF-E

## Terminators

Item	Description <sup>(1)</sup>	Catalog Number
Terminators	For use with 3.7 kW (5 HP) and below drives	1204-TFA1
	For use with 1.5 kW (2 HP) and above drives	1204-TFB2

(1) For selection information, see Appendix A of the Wiring and Grounding for Pulse Width Modulated (PWM) AC Drives Installation Instructions, publication [DRIVES-IN001](#).

## Human Interface Modules (HIM) Option Kits and Accessories

Item	Description	Catalog Number
LCD Display, Remote Panel Mount	Digital speed control CopyCat capable IP 66 (NEMA Type 4X/12) indoor use only Includes 2.0 m (6.56 ft) cable	22-HIM-C2S
LCD Display, Remote Handheld	Digital speed control Full numeric keyboard CopyCat capable IP 30 (NEMA Type 1) Includes 1.0 m (3.28 ft) cable Panel mount with optional Bezel Kit	22-HIM-A3
Bezel Kit	Panel mount for LCD Display, Remote Handheld unit, IP 30 (NEMA Type 1) Includes 2.0 m (6.56 ft) DSI cable	22-HIM-B1
DSI HIM Cable (DSI HIM to RJ45 cable)	1.0 m (3.3 ft)	22-HIM-H10
	2.9 m (9.51 ft)	22-HIM-H30

## IP 30/NEMA 1/UL Type 1 Kit

Item	Description	Frame Size	Catalog Number
IP 30/NEMA 1/UL Type 1 Kit	Field installed kit. Converts the drive to an IP 30/NEMA 1/UL Type 1 enclosure. Includes conduit box with mounting screws and plastic top panel.	A	25-JBAA
		B	25-JBAB
		C	25-JBAC
		D	25-JBAD
		E	25-JBAE

### Control Module Fan Kit

Item	Description	Frame Size	Catalog Number
Control Module Fan Kit	For use with the drive in environments with ambient temperatures up to 70 °C (158 °F) or horizontal mounting	A...D	25-FAN1-70C
		E	25-FAN2-70C

### Incremental Encoder Input Option

Item	Description	Catalog Number
Incremental Encoder	Incremental encoder input option board	25-ENC-1



**WARNING:** Only the 25-ENC-1 Encoder works properly in the PowerFlex 525 drive. Installing an incorrect encoder card, such as the PowerFlex 527 25-ENC-2 will damage the PowerFlex 525 drive.

### Bulletin 160 to PowerFlex 520-series Mounting Adapter Plate

Item	Description	B160 Frame Size	Catalog Number
Mounting Adapter Plate	For use with drive when replacing Bulletin 160 drives in existing installations to a PowerFlex 520-series drive. Select the catalog number based on the frame size of your Bulletin 160 drive.	A	25-MAP-FA
		B	25-MAP-FB

### PowerFlex 4/40/40P IP 20 to PowerFlex 520-series Drives

Item	Description	PF4/40/40P Frame Size	Catalog Number
Mounting Adapter Plate	For use with drive when replacing PowerFlex 4/40/40P IP 20 drives in existing installations to a PowerFlex 520-series drive. Select the catalog number based on the frame size of your PowerFlex 4/40/40P drives.	A	25-AP0-FA
		B	25-AP0-FB
		C	25-AP0-FC
		C <sup>(1)</sup>	25-AP0-FD
	For use with drive when replacing PowerFlex 4/40/40P IP 20 drives with external EMC filter in existing installations to a PowerFlex 520-series drive with external EMC filter. Select the catalog number based on the frame size of your PowerFlex 4/40/40P drives.	A	25-API-FA
		B	25-API-FB
		C <sup>(2)</sup>	25-API-FC

(1) Only for 3-phase 200...240V: 7.5 kW/10 HP, 3-phase 380...480V: 11 kW/15 HP, and 3-phase 500...600V: 11 kW/15 HP

(2) PowerFlex 4/40/40P + EMC filter adapter plate is not applicable for 3-phase 200...240V: 7.5 kW/10 HP, 3-phase 380...480V: 11 kW/15 HP, and 3-phase 500...600V: 11 kW/15 HP

## Replacement Parts

### PowerFlex 520-series Power Module

Item	Description
PowerFlex 520-series Power Module	Replacement power module for use with PowerFlex 520-series drives. Includes: <ul style="list-style-type: none"> <li>• Power Module</li> <li>• Power Module Front Cover</li> <li>• Power Terminal Guard</li> <li>• Heatsink Fan</li> </ul>

Output Ratings					Input Voltage Range	Frame Size	Catalog Number
Normal Duty		Heavy Duty		Output Current (A)			
HP	kW	HP	kW				
<b>100...120V AC (-15%, +10%) – 1-phase Input, 0...230V 3-phase Output</b>							
0.25	0.2	0.25	0.2	1.6	85...132	A	25-PM1-V1P6
0.5	0.4	0.5	0.4	2.5	85...132	A	25-PM1-V2P5
1.0	0.75	1.0	0.75	4.8	85...132	B	25-PM1-V4P8
1.5	1.1	1.5	1.1	6.0	85...132	B	25-PM1-V6P0

Output Ratings (Continued)					Input Voltage Range	Frame Size	Catalog Number
Normal Duty		Heavy Duty		Output Current (A)			
HP	kW	HP	kW				
<b>200...240V AC (-15%, +10%) - 1-phase Input, 0...230V 3-phase Output</b>							
0.25	0.2	0.25	0.2	1.6	170...264	A	25-PM1-A1P6
0.5	0.4	0.5	0.4	2.5	170...264	A	25-PM1-A2P5
1.0	0.75	1.0	0.75	4.8	170...264	A	25-PM1-A4P8
2.0	1.5	2.0	1.5	8.0	170...264	B	25-PM1-A8P0
3.0	2.2	3.0	2.2	11.0	170...264	B	25-PM1-A011
<b>200...240V AC (-15%, +10%) - 1-phase Input with EMC Filter, 0...230V 3-phase Output</b>							
0.25	0.2	0.25	0.2	1.6	170...264	A	25-PM2-A1P6
0.5	0.4	0.5	0.4	2.5	170...264	A	25-PM2-A2P5
1.0	0.75	1.0	0.75	4.8	170...264	A	25-PM2-A4P8
2.0	1.5	2.0	1.5	8.0	170...264	B	25-PM2-A8P0
3.0	2.2	3.0	2.2	11.0	170...264	B	25-PM2-A011
<b>200...240V AC (-15%, +10%) - 3-phase Input, 0...230V 3-phase Output</b>							
0.25	0.2	0.25	0.2	1.6	170...264	A	25-PM1-B1P6
0.5	0.4	0.5	0.4	2.5	170...264	A	25-PM1-B2P5
1.0	0.75	1.0	0.75	5.0	170...264	A	25-PM1-B5P0
2.0	1.5	2.0	1.5	8.0	170...264	A	25-PM1-B8P0
3.0	2.2	3.0	2.2	11.0	170...264	A	25-PM1-B011
5.0	4.0	5.0	4.0	17.5	170...264	B	25-PM1-B017
7.5	5.5	7.5	5.5	24.0	170...264	C	25-PM1-B024
10.0	7.5	10.0	7.5	32.2	170...264	D	25-PM1-B032
15.0	11.0	10.0	7.5	48.3	170...264	E	25-PM1-B048
20.0	15.0	15.0	11.0	62.1	170...264	E	25-PM1-B062
<b>380...480V AC (-15%, +10%) - 3-phase Input, 0...460V 3-phase Output</b>							
0.5	0.4	0.5	0.4	1.4	323...528	A	25-PM1-D1P4
1.0	0.75	1.0	0.75	2.3	323...528	A	25-PM1-D2P3
2.0	1.5	2.0	1.5	4.0	323...528	A	25-PM1-D4P0
3.0	2.2	3.0	2.2	6.0	323...528	A	25-PM1-D6P0
5.0	4.0	5.0	4.0	10.5	323...528	B	25-PM1-D010
7.5	5.5	7.5	5.5	13.0	323...528	C	25-PM1-D013
10.0	7.5	10.0	7.5	17.0	323...528	C	25-PM1-D017
15.0	11.0	15.0	11.0	24.0	323...528	D	25-PM1-D024
20.0	15.0	15.0	11.0	30.0	323...528	D	25-PM1-D030
<b>380...480V AC (-15%, +10%) - 3-phase Input with EMC Filter, 0...460V 3-phase Output</b>							
0.5	0.4	0.5	0.4	1.4	323...528	A	25-PM2-D1P4
1.0	0.75	1.0	0.75	2.3	323...528	A	25-PM2-D2P3
2.0	1.5	2.0	1.5	4.0	323...528	A	25-PM2-D4P0
3.0	2.2	3.0	2.2	6.0	323...528	A	25-PM2-D6P0
5.0	4.0	5.0	4.0	10.5	323...528	B	25-PM2-D010
7.5	5.5	7.5	5.5	13.0	323...528	C	25-PM2-D013
10.0	7.5	10.0	7.5	17.0	323...528	C	25-PM2-D017
15.0	11.0	15.0	11.0	24.0	323...528	D	25-PM2-D024
20.0	15.0	15.0	11.0	30.0	323...528	D	25-PM2-D030
25.0	18.5	20.0	15.0	37.0	323...528	E	25-PM2-D037
30.0	22.0	25.0	18.5	43.0	323...528	E	25-PM2-D043
<b>525...600V AC (-15%, +10%) - 3-phase Input, 0...575V 3-phase Output</b>							
0.5	0.4	0.5	0.4	0.9	446...660	A	25-PM1-E0P9
1.0	0.75	1.0	0.75	1.7	446...660	A	25-PM1-E1P7
2.0	1.5	2.0	1.5	3.0	446...660	A	25-PM1-E3P0
3.0	2.2	3.0	2.2	4.2	446...660	A	25-PM1-E4P2
5.0	4.0	5.0	4.0	6.6	446...660	B	25-PM1-E6P6

Output Ratings (Continued)					Input Voltage Range	Frame Size	Catalog Number
Normal Duty		Heavy Duty		Output Current (A)			
HP	kW	HP	kW				
7.5	5.5	7.5	5.5	9.9	446...660	C	25-PM1-E9P9
10.0	7.5	10.0	7.5	12.0	446...660	C	25-PM1-E012
15.0	11.0	15.0	11.0	19.0	446...660	D	25-PM1-E019
20.0	15.0	15.0	11.0	22.0	446...660	D	25-PM1-E022
25.0	18.5	20.0	15.0	27.0	446...660	E	25-PM1-E027
30.0	22.0	25.0	18.5	32.0	446...660	E	25-PM1-E032

**PowerFlex 520-series Control Module**

Item	Description	Frame Size	Catalog Number
PowerFlex 523 Control Module	Replacement control module for use with PowerFlex 520-series drives. Includes: • Control Module • Control Module Front Cover	A...E	25A-CTM1
PowerFlex 525 Control Module			25B-CTM1

**Other Parts**

Item	Description	Frame Size	Catalog Number
PowerFlex 523 Control Module Front Cover	Replacement cover for the control module I/O terminals, EtherNet/IP, and DSI ports.	A...E	25A-CTMFC1
PowerFlex 525 Control Module Front Cover			25B-CTMFC1
PowerFlex 520-series Power Module Front Cover	Replacement cover for the PowerFlex 520-series power module.	B	25-PMFC-FB
		C	25-PMFC-FC
		D	25-PMFC-FD
		E	25-PMFC-FE
PowerFlex 520-series Power Terminal Guard	Replacement finger guard for power terminals.	A	25-PTG1-FA
		B	25-PTG1-FB
		C	25-PTG1-FC
		D	25-PTG1-FD
		E	25-PTG1-FE
PowerFlex 520-series Heatsink Fan Kit	Replacement fan for drive power module.	A	25-FAN1-FA
		B	25-FAN1-FB
		C	25-FAN1-FC
		D	25-FAN1-FD
		E	25-FAN1-FE

**Communication Option Kits and Accessories**

Item	Description	Catalog Number
Communication Adapters	Embedded communication options for use with the PowerFlex 520-series drives: • DeviceNet • Dual-port EtherNet/IP • PROFIBUS DP-V1 • PROFINET	25-COMM-D 25-COMM-E2P 25-COMM-P 25-COMM-PNET2P
Compact I/O™ Module	Three channels	1769-SM2
Universal Serial Bus (USB) Converter Module	Provides serial communication via DF1 protocol for use with Connected Components Workbench software. Includes: • 2 m (6.6 ft) USB cable (1) • 20-HIM-H10 cable (1) • 22-HIM-H10 cable (1)	1203-USB
Serial Converter Module (RS-485 to RS-232)	Provides serial communication via DF1 protocol for use with Connected Components Workbench software. Includes: • DSI to RS-232 serial converter (1) • 1203-SFC serial cable (1) • 22-RJ45CBL-C20 cable (1)	22-SCM-232
DSI Cable	2.0 m (6.6 ft) RJ45 to RJ45 cable, male to male connectors	22-RJ45CBL-C20

## Communication Option Kits and Accessories (Continued)

Item	Description	Catalog Number
Serial Cable	2.0 m (6.6 ft) serial cable with a locking low profile connector to connect to the serial converter and a 9-pin subminiature D female connector to connect to a computer.	1203-SFC
Splitter Cable	RJ45 one to two port splitter cable (Modbus only)	AK-U0-RJ45-SC1
Terminating Resistors	RJ45 120 Ω resistors (2 pieces)	AK-U0-RJ45-TR1
Terminal Block	RJ45 Two-position terminal block (5 pieces)	AK-U0-RJ45-TB2P

## Programming Software

Item	Description
Connected Components Workbench Software	Windows-based software packages for programming and configuring Allen-Bradley® drives and other Rockwell Automation products. Compatibility: Microsoft Windows® Server 2012 <sup>(1)</sup> , Windows Server 2012 R2, Windows Server 2016 <sup>(1)</sup> , Windows Server 2019, Windows 10 IoT Enterprise 2016 LTSC 64-bit, Windows 10 IoT Enterprise 2019 LTSC, Windows 10, and Windows 11 <sup>(2)</sup> All supported operating systems require .NET Framework 3.5 SP1 to be installed. You can download Connected Components Workbench Standard Edition software for free at <a href="http://rok.auto/pcdc">rok.auto/pcdc</a> . To purchase Connected Components Workbench Developer Edition software, visit <a href="http://rok.auto/ccw">rok.auto/ccw</a> .

(1) Requires Connected Components Workbench software version 20.01.00 or earlier.

(2) Requires Connected Components Workbench software version 20.01.00 or later.

## Bulletin 1321-3R Series Line Reactors

Output Ratings <sup>(1)</sup>				Input Line Reactor <sup>(2)(3)</sup>		Output Line Reactor <sup>(2)(3)</sup>	
Normal Duty		Heavy Duty		IP 00 (Open Style)	IP 11 (NEMA/UL Type 1)	IP 00 (Open Style)	IP 11 (NEMA/UL Type 1)
HP	kW	HP	kW	Catalog Number	Catalog Number	Catalog Number	Catalog Number
<b>200...240V 50/60 Hz 1-phase<sup>(4)</sup></b>							
0.25	0.2	0.25	0.2	1321-3R4-A	1321-3RA4-A	1321-3R2-D	1321-3RA2-D
0.5	0.4	0.5	0.4	1321-3R8-A	1321-3RA8-A	1321-3R2-D	1321-3RA2-D
1.0	0.75	1.0	0.75	1321-3R8-A	1321-3RA8-A	1321-3R4-A	1321-3RA4-A
2.0	1.5	2.0	1.5	1321-3R18-A	1321-3RA18-A	1321-3R8-A	1321-3RA8-A
3.0	2.2	3.0	2.2	1321-3R18-A	1321-3RA18-A	1321-3R12-A	1321-3RA12-A
<b>200...2240V 50/60 Hz 3-phase</b>							
0.25	0.2	0.25	0.2	1321-3R2-D	1321-3RA2-D	1321-3R2-D	1321-3RA2-D
0.5	0.4	0.5	0.4	1321-3R2-D	1321-3RA2-D	1321-3R2-D	1321-3RA2-D
1.0	0.75	1.0	0.75	1321-3R4-A	1321-3RA4-A	1321-3R4-A	1321-3RA4-A
2.0	1.5	2.0	1.5	1321-3R8-A	1321-3RA8-A	1321-3R8-A	1321-3RA8-A
3.0	2.2	3.0	2.2	1321-3R12-A	1321-3RA12-A	1321-3R12-A	1321-3RA12-A
5.0	4.0	5.0	4.0	1321-3R18-A	1321-3RA18-A	1321-3R18-A	1321-3RA18-A
7.5	5.5	7.5	5.5	1321-3R25-A	1321-3RA25-A	1321-3R25-A	1321-3RA25-A
10.0	7.5	10.0	7.5	1321-3R35-A	1321-3RA35-A	1321-3R35-A	1321-3RA35-A
15.0	11.0	10.0	7.5	1321-3R45-A	1321-3RA45-A	1321-3R45-A	1321-3RA45-A
20.0	15.0	15.0	11.0	1321-3R55-A (ND) 1321-3R45-A (HD)	1321-3RA55-A (ND) 1321-3RA45-A (HD)	1321-3R55-A (ND) 1321-3R45-A (HD)	1321-3RA55-A (ND) 1321-3RA45-A (HD)
<b>380...2480V 50/60 Hz 3-phase</b>							
0.5	0.4	0.5	0.4	1321-3R2-B	1321-3RA2-B	1321-3R2-B	1321-3RA2-B
1.0	0.75	1.0	0.75	1321-3R4-C	1321-3RA4-C	1321-3R4-C	1321-3RA4-C
2.0	1.5	2.0	1.5	1321-3R4-B	1321-3RA4-B	1321-3R4-B	1321-3RA4-B
3.0	2.2	3.0	2.2	1321-3R8-C	1321-3RA8-C	1321-3R8-C	1321-3RA8-C
5.0	4.0	5.0	4.0	1321-3R12-B	1321-3RA12-B	1321-3R12-B	1321-3RA12-B
7.5	5.5	7.5	5.5	1321-3R12-B	1321-3RA12-B	1321-3R12-B	1321-3RA12-B
10.0	7.5	10.0	7.5	1321-3R18-B	1321-3RA18-B	1321-3R18-B	1321-3RA18-B
15.0	11.0	15.0	11.0	1321-3R25-B	1321-3RA25-B	1321-3R25-B	1321-3RA25-B
20.0	15.0	15.0	11.0	1321-3R35-B (ND) 1321-3R25-B (HD)	1321-3RA35-B (ND) 1321-3RA25-B (HD)	1321-3R35-B (ND) 1321-3R25-B (HD)	1321-3RA35-B (ND) 1321-3RA25-B (HD)
25.0	18.5	20.0	15.0	1321-3R35-B	1321-3RA35-B	1321-3R35-B	1321-3RA35-B

**Bulletin 1321-3R Series Line Reactors (Continued)**

Output Ratings <sup>(1)</sup>				Input Line Reactor <sup>(2)(3)</sup>		Output Line Reactor <sup>(2)(3)</sup>	
Normal Duty		Heavy Duty		IP 00 (Open Style)	IP 11 (NEMA/UL Type 1)	IP 00 (Open Style)	IP 11 (NEMA/UL Type 1)
HP	kW	HP	kW	Catalog Number	Catalog Number	Catalog Number	Catalog Number
30.0	22.0	25.0	18.5	1321-3R45-B (ND) 1321-3R35-B (HD)	1321-3RA45-B (ND) 1321-3RA35-B (HD)	1321-3R45-B (ND) 1321-3R35-B (HD)	1321-3RA45-B (ND) 1321-3RA35-B (HD)
<b>525...2600V 50/60 Hz 3-phase</b>							
0.5	0.4	0.5	0.4	1321-3R1-C	1321-3RA1-C	1321-3R1-C	1321-3RA1-C
1.0	0.75	1.0	0.75	1321-3R2-B	1321-3RA2-B	1321-3R2-B	1321-3RA2-B
2.0	1.5	2.0	1.5	1321-3R4-C	1321-3RA4-C	1321-3R4-C	1321-3RA4-C
3.0	2.2	3.0	2.2	1321-3R4-B	1321-3RA4-B	1321-3R4-B	1321-3RA4-B
5.0	4.0	5.0	4.0	1321-3R8-C	1321-3RA8-C	1321-3R8-C	1321-3RA8-C
7.5	5.5	7.5	5.5	1321-3R12-B	1321-3RA12-B	1321-3R12-B	1321-3RA12-B
10.0	7.5	10.0	7.5	1321-3R12-B	1321-3RA12-B	1321-3R12-B	1321-3RA12-B
15.0	11.0	15.0	11.0	1321-3R18-B	1321-3RA18-B	1321-3R18-B	1321-3RA18-B
20.0	15.0	15.0	11.0	1321-3R25-B (ND) 1321-3R18-B (HD)	1321-3RA25-B (ND) 1321-3RA18-B (HD)	1321-3R25-B (ND) 1321-3R18-B (HD)	1321-3RA25-B (ND) 1321-3RA18-B (HD)
25.0	18.5	20.0	15.0	1321-3R35-C (ND) 1321-3R25-C (HD)	1321-3RA35-C (ND) 1321-3RA25-C (HD)	1321-3R35-C (ND) 1321-3R25-C (HD)	1321-3RA35-C (ND) 1321-3RA25-C (HD)
30.0	22.0	25.0	18.5	1321-3R35-C (ND) 1321-3R25-B (HD)	1321-3RA35-C (ND) 1321-3RA25-B (HD)	1321-3R35-C (ND) 1321-3R25-B (HD)	1321-3RA35-C (ND) 1321-3RA25-B (HD)

(1) Normal Duty and Heavy Duty ratings for 15 HP (11 kW) and below are identical except for 200...240V 3-phase 15 HP (11 kW) drive.  
 (2) Catalog numbers that are listed are for 3% impedance. 5% impedance reactor types are also available. See the 1321 Power Conditioning Products Technical Data, publication [1321-TD001](#).  
 (3) Input line reactors were sized based on the NEC fundamental motor amps. Output line reactors were sized based on the VFD rated output currents.  
 (4) Standard 3-phase reactors can be used for 1-phase applications by routing each of the two supply conductors through an outside coil and leaving the center open.

# Accessory Dimensions

## IP 30/NEMA 1/UL Type 1 Kit

Dimensions are in mm and (in.)

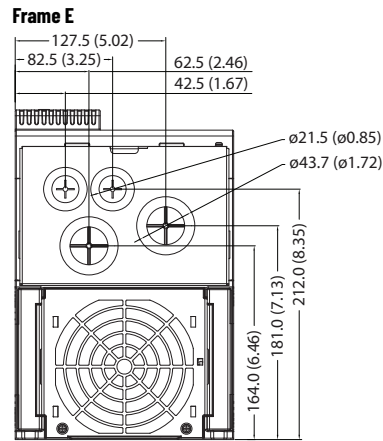
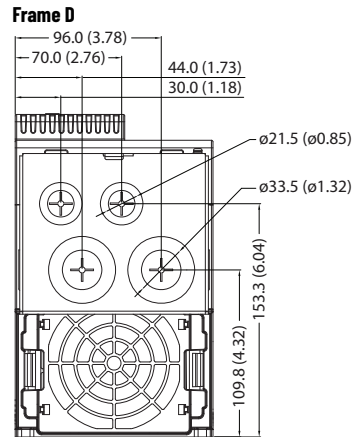
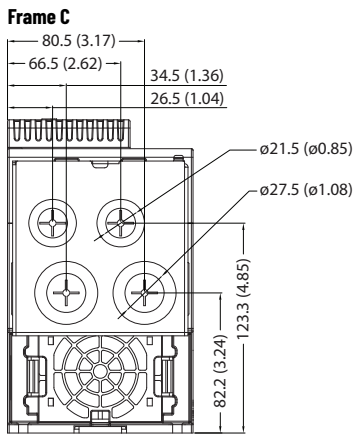
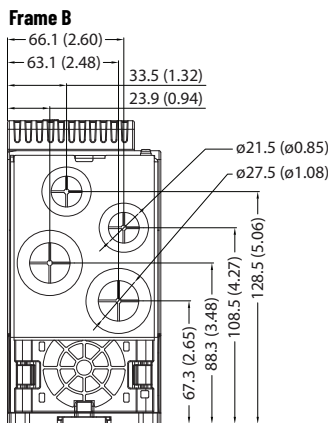
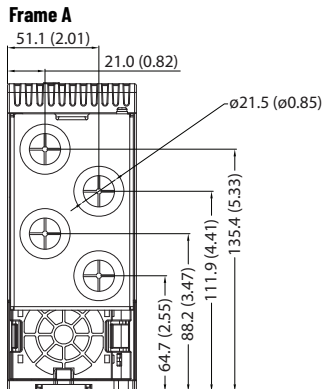
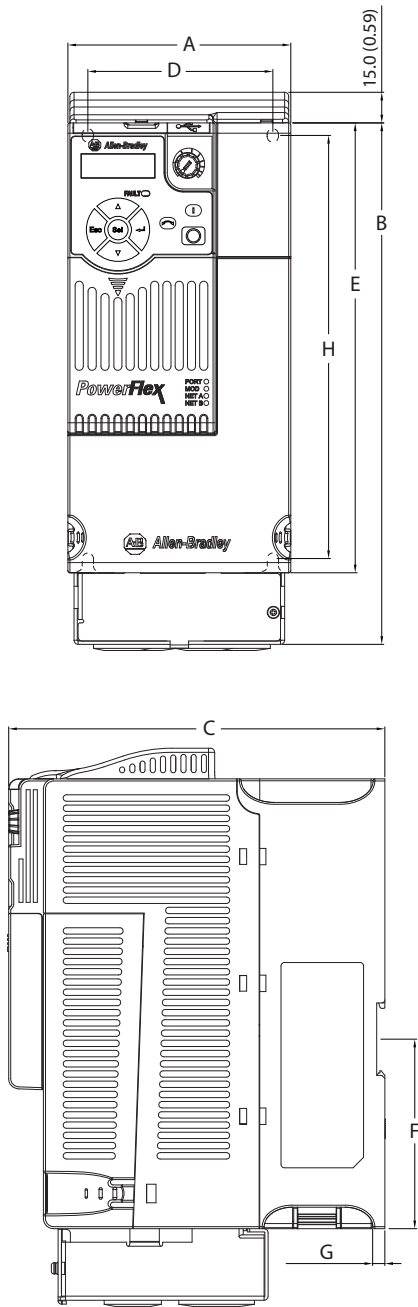

Frame Size	Dimensions							
	A	B	C	D	E	F	G	H
A	72.0 (2.83)	219.0 (8.62)	172.0 (6.77)	57.5 (2.26)	152.0 (5.98)	92.7 (3.65)	6.0 (0.24)	140.0 (5.51)
B	87.0 (3.43)	218.0 (8.58)	172.0 (6.77)	72.5 (2.85)	180.0 (7.09)	92.7 (3.65)	6.0 (0.24)	168.0 (6.61)
C	109.0 (4.29)	255.0 (10.04)	184.0 (7.24)	90.5 (3.56)	222.0 (8.66)	92.7 (3.65)	6.0 (0.24)	207.0 (8.15)
D	130.0 (5.12)	295.0 (11.61)	212.0 (8.35)	116.0 (4.57)	260.0 (10.24)	—	6.0 (0.24)	247.0 (9.74)
E	185.0 (7.28)	350.0 (13.78)	279.0 (10.98)	160.0 (6.30)	300.0 (11.81)	—	7.6 (0.30)	280.0 (11.02)

Control Module Fan Kit

Dimensions are in mm and (in.)

Frame A...D

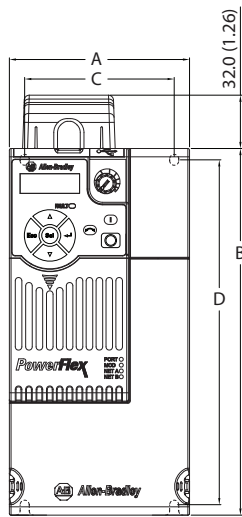

Frame E

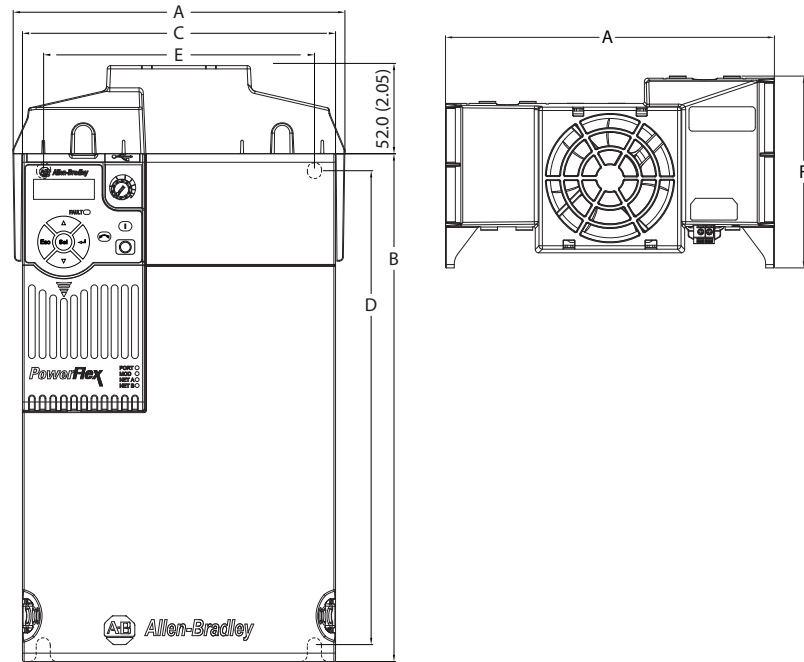

Frame Size	Dimensions					
	A	B	C	D	E	F
A	72.0 (2.83)	152.0 (5.98)	57.5 (2.26)	140.0 (5.51)	56.0 (2.20)	99.8 (3.93)
B	87.0 (3.43)	180.0 (7.09)	72.5 (2.85)	168.0 (6.61)	56.0 (2.20)	99.8 (3.93)
C	109.0 (4.29)	220.0 (8.66)	90.5 (3.56)	207.0 (8.15)	56.0 (2.20)	99.8 (3.93)
D	130.0 (5.12)	260.0 (10.24)	116.0 (4.57)	247.0 (9.72)	56.0 (2.20)	99.8 (3.93)
E	196.0 (7.72)	300.0 (11.81)	185.0 (7.28)	280.0 (11.02)	196.0 (7.72)	114.3 (4.50)

Specifications	25-FAN1-70C	25-FAN2-70C
Rated Voltage	24V DC	
Operation Voltage	14...27.6V DC	
Input Current	0.1 A	0.15 A
Speed (Reference)	7000 rpm	4500 ±10% rpm
Airflow, max (At zero static pressure)	0.575 m <sup>3</sup> /min	1.574 m <sup>3</sup> /min
Air Pressure max (At zero airflow)	7.70 mm H <sub>2</sub> O	9.598 mm H <sub>2</sub> O
Acoustical Noise	40.5 dB-A	46.0 dB-A
Insulation Type	UL Class A	
Frame Size	Frame A...D	Frame E
Wire Size	0.32 mm <sup>2</sup> (22 AWG)	
Torque	0.29...0.39 N•m (2.6...3.47 lb•in)	

### EMC Line Filter

Dimensions are in mm and (in.)

**Frame A...D**

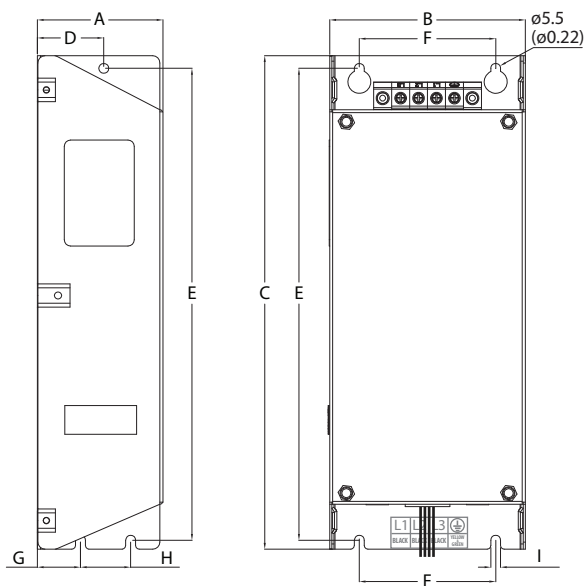

**Frame E**

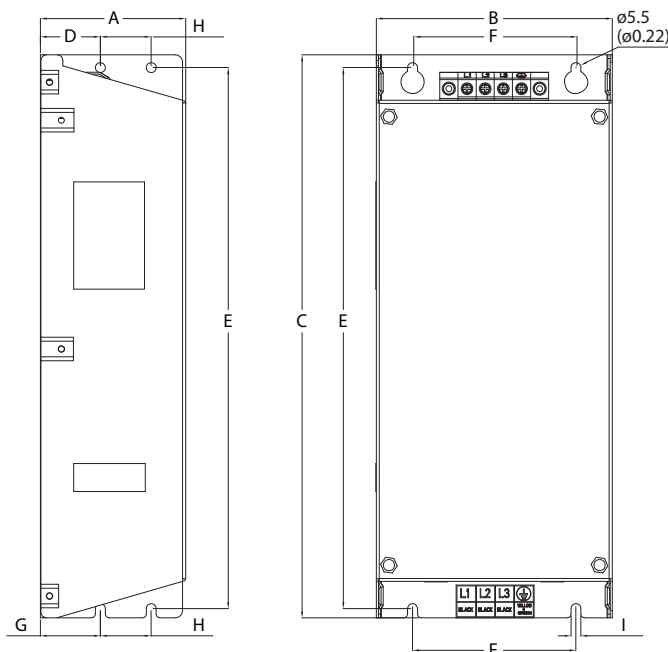

Frame Size	Dimensions								
	A	B	C	D	E	F	G	H	I
A	55.0 (2.17)	72.0 (2.83)	234.0 (9.21)	30.0 (1.18)	223.0 (8.78)	54.0 (2.13)	20.0 (0.79)	23.0 (0.91)	5.5 (0.22)
B	70.0 (2.76)	87.0 (3.43)	270.0 (10.63)	35.0 (1.38)	258.0 (10.16)	58.0 (2.28)	25.0 (0.98)	24.0 (0.94)	5.5 (0.22)
C	70.0 (2.76)	109.0 (4.29)	275.0 (10.83)	37.0 (1.46)	263.0 (10.35)	76.0 (2.99)	25.0 (0.98)	28.0 (1.10)	5.5 (0.22)
D	80.0 (3.15)	130.0 (5.12)	310.0 (12.20)	33.0 (1.30)	298.0 (11.73)	90.0 (3.54)	33.0 (1.30)	28.0 (1.10)	5.5 (0.22)
E	80.0 (3.15)	155.0 (6.10)	390.0 (15.35)	33.0 (1.30)	375.0 (14.76)	110.0 (4.33)	33.0 (1.30)	28.0 (1.10)	5.5 (0.22)

## Adapter Plate Dimensions

### Adapter Plate - Frame A

Dimensions are in mm and (in.)

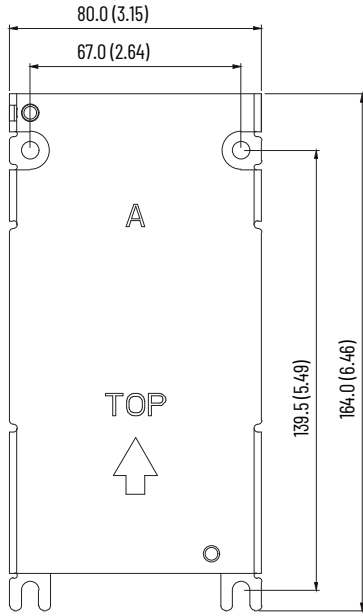

25-AP0-FA

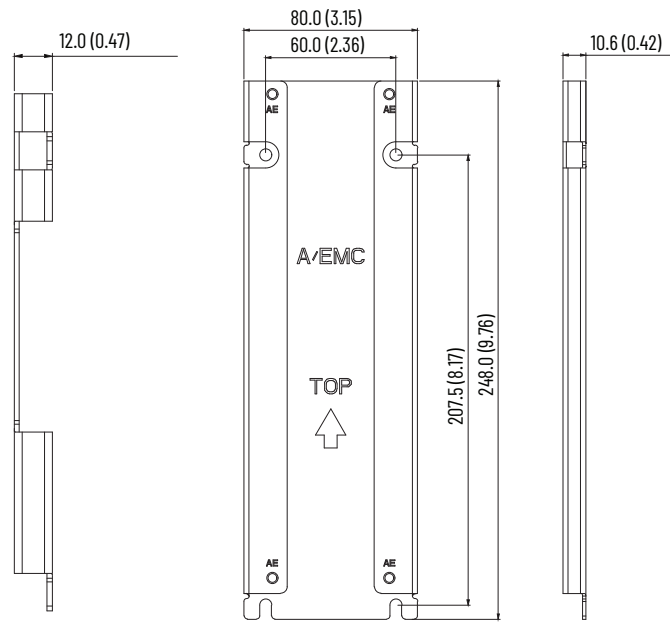

25-AP1-FA

### Adapter Plate- Frame B

Dimensions are in mm and (in.)

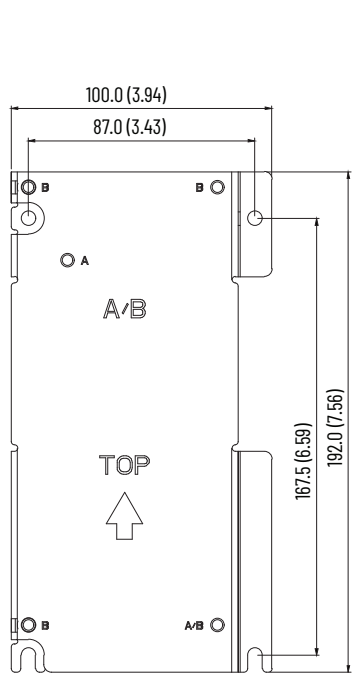

25-AP0-FB

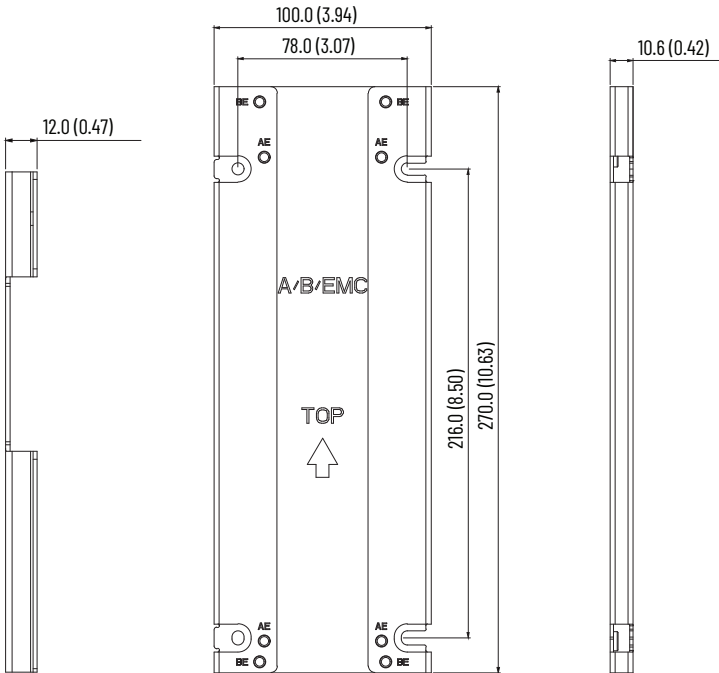

25-AP1-FB

### Adapter Plate- Frame C

Dimensions are in mm and (in.)

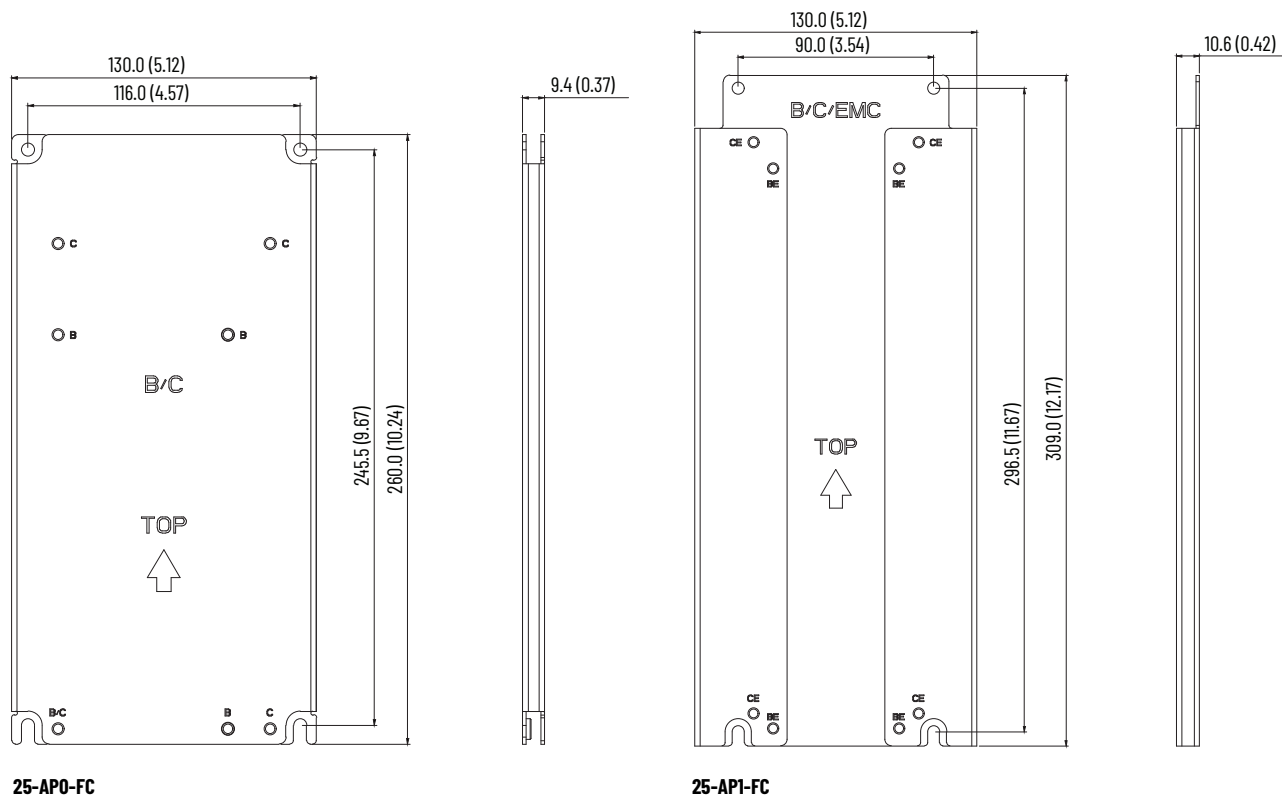

### Adapter Plate- Frame D

Dimensions are in mm and (in.)

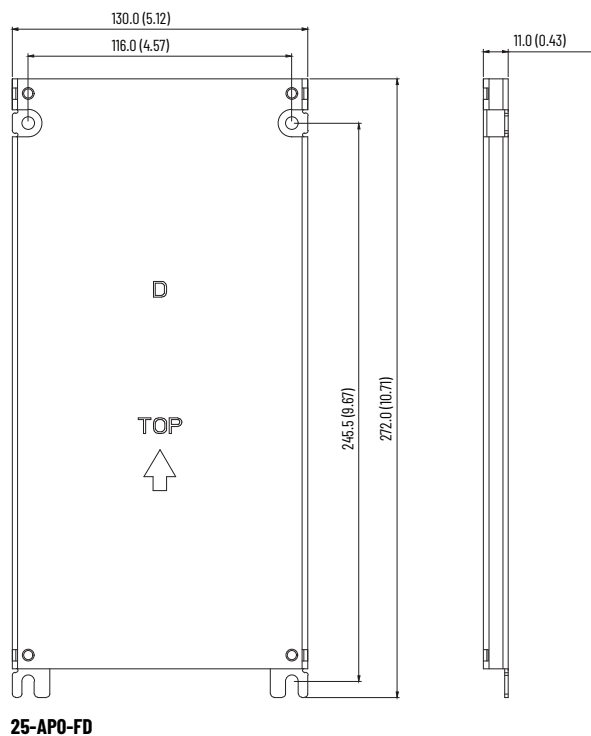

## Safe Torque Off Function

The PowerFlex 525 Safe Torque Off function, when used with other safety components, helps provide protection according to EN ISO 13849 and EN62061 for Safe Torque Off and protection against restart. The PowerFlex 525 STO function is just one component in a safety control system. Components in the system must be chosen and applied appropriately to achieve the desired level of operator safeguarding.

### PowerFlex 525 Safe Torque Off Overview

The PowerFlex 525 STO function:

- Provides the STO function that is defined in EN IEC 61800-5-2.
- Blocks gate-firing signals from reaching the IGBT output devices of the drive. This helps prevent the IGBTs from switching in the sequence necessary to generate torque in the motor.
- Can be used in combination with other safety devices to fulfill the requirements of a system Safe Torque Off function, which satisfies Category 3 / PLd according to EN ISO 13849-1 and SIL CL2 according to EN 62061, IEC 61508, and EN 61800-5-2.

---

**IMPORTANT** The function is suitable for performing mechanical work on the drive system or affected area of a machine only. It does not provide electrical safety.

---

### EC Type Examination Certification

TÜV Rheinland has certified the PowerFlex 525 Safe Torque Off function compliant with the requirements for machines that are defined in Annex I of the EC Directive 2006/42/EC, and that it complies with the requirements of the relevant standards that are listed as follows:

- EN ISO 13849-1 Safety of machinery – Safety related parts of control systems – Part 1: General principles for design. (PowerFlex 525 STO achieves Category 3 / PLd)
- EN 61800-5-2 Adjustable speed electrical power drive systems – Part 5-2 Safety requirements – Functional. (PowerFlex 525 STO achieves SIL CL 2)
- EN 62061 Safety of machinery – Functional safety of safety-related electrical, electronic, and programmable electronic control systems.
- IEC 61508 Part 1-7 Functional safety of electrical/electronic/programmable electronic safety-related systems – Parts 1-7.

TÜV also certifies that the PowerFlex 525 STO can be used in applications up to Category 3/ PLd according to EN ISO 13849-1 and SIL 2 according to EN 62061 / EN 61800-5-2 / IEC 61508.

The TÜV Rheinland certificate can be found at [rok.auto/certifications](http://rok.auto/certifications).

## Safety Concept

The PowerFlex 525 Safe Torque Off function is suitable for use in safety applications up to and including Category 3 / PLd according to EN ISO 13849-1 and SIL 2 according to EN 62061 / EN 61800-5-2 / IEC 61508.

In addition, the PowerFlex 525 STO function can be used together with other components in a safety application to achieve an overall Category 3 / PLe according to EN ISO 13849-1 and SIL 3 according to EN 62061 and IEC 61508. This is illustrated in Example 3 on [page 50](#).

Safety requirements are based on the standards current at the time of certification.

The PowerFlex 525 STO function is intended for use in safety-related applications where the de-energized state is considered to be the safe state. The examples that are shown here are based on achieving de-energization as the safe state for typical Machine Safety and Emergency Shutdown (ESD) systems.

### *PFH and PFH Data*

The probability of dangerous failure on demand (PFD) and average frequency of a dangerous failure per hour (PFH) calculations are based on the equations from Part 6 of EN 61508.

This table provides data for a 20-year proof test interval and demonstrates the worst-case effect of various configuration changes on the data.

### **PFH and PFH**

<b>Attribute</b>	<b>Value</b>
PFD	6.62E-05 (MTTF = 3593 years)
PFH <sub>d</sub>	8.13E-10
SFF	83%
DC	62.5%
CAT	3
HFT	1 (1002)
PTI	20 YEARS
Hardware Type	Type A

### *Safety Reaction Time*

The safety reaction time from an input signal condition that triggers a safe stop, to the initiation of the configured Stop Type, is 100 ms (maximum).



**Stop Category 0 - Coast with Two PowerFlex 525 Drives**

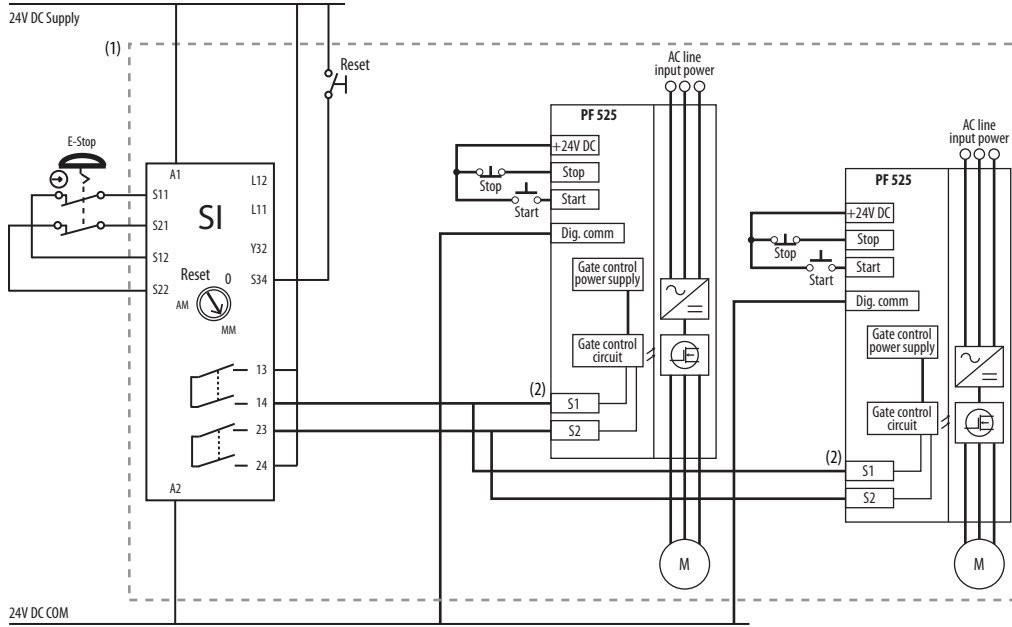

- (1) An enclosure is recommended. External wiring failure modes must be considered as described in EN ISO 13849-2. An enclosure or other measure to exclude these failure modes should be used.
- (2) Each safety input draws 6 mA from the supply.

**Example 2 - Safe Torque Off Connection with Controlled Stop Action, SIL 2/PLD**

**Stop Category 1- Controlled**

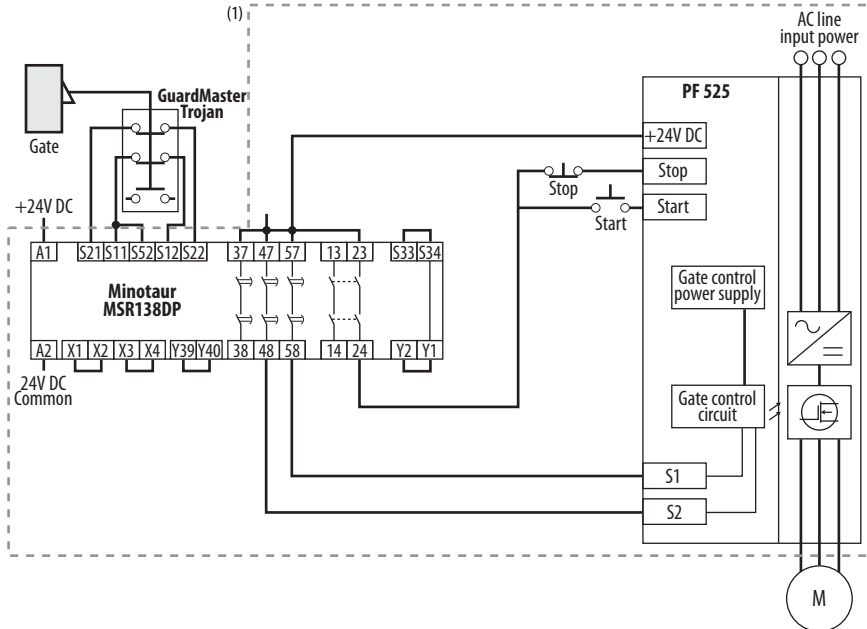

- (1) An enclosure is recommended. External wiring failure modes must be considered as described in EN ISO 13849-2. An enclosure or other measure to exclude these failure modes should be used.

Example 3 – Safe Torque Off Connection with Coast-to-Stop Action Using External +24V supply, SIL 3/PLe

Stop Category 0 – Coast

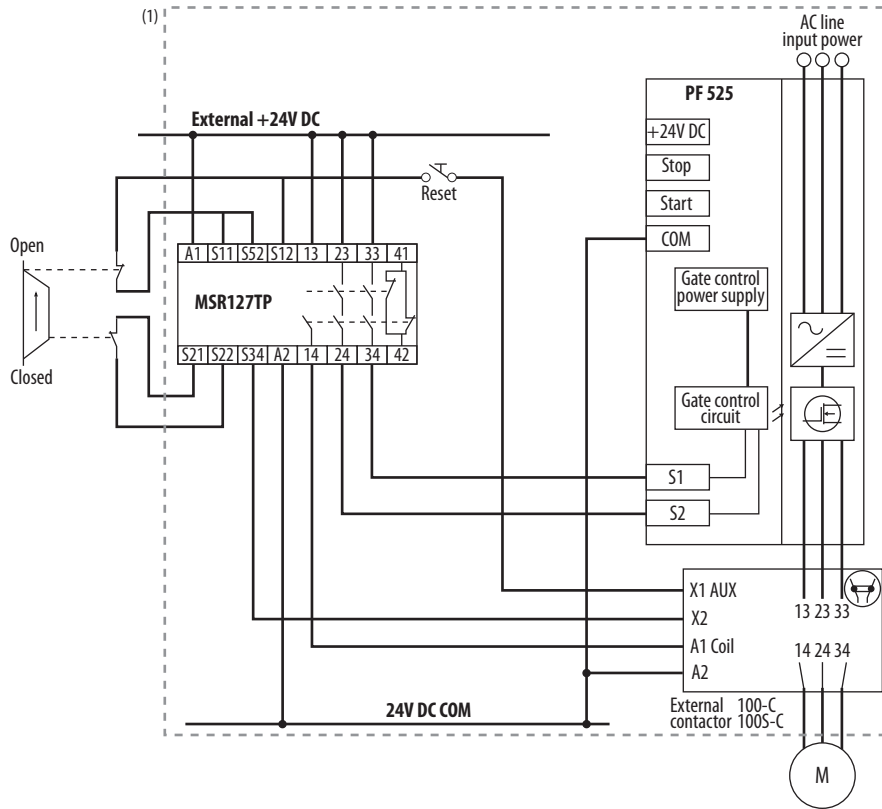

(1) An enclosure is recommended. External wiring failure modes must be considered as described in EN ISO 13849-2. An enclosure or other measure to exclude these failure modes should be used.

## Additional Resources

These documents contain additional information concerning related products from Rockwell Automation. You can view or download publications at [rok.auto/literature](http://rok.auto/literature).

### Additional Resources

Resource	Description
PowerFlex 520-series Adjustable Frequency AC Drive User Manual, publication <a href="#">520-UM001</a>	Describes how to configure, use, and troubleshoot PowerFlex 520-series drives.
PowerFlex 4-class HIM (DSI) Quick Reference, publication <a href="#">22HIM-0R001</a>	Provides descriptions and information on PowerFlex 4-class human interface modules (HIM).
PowerFlex 525 Embedded EtherNet/IP Adapter User Manual, publication <a href="#">520COM-UM001</a>	Describes how to use the embedded EtherNet/IP adapter on the PowerFlex 525 drive for network communication.
PowerFlex 525 DeviceNet Adapter User Manual, publication <a href="#">520COM-UM002</a>	Describes how to use the DeviceNet adapter for PowerFlex 520-series drives for network communication.
PowerFlex 25-COMM-E2P Dual-port EtherNet/IP Adapter User Manual, publication <a href="#">520COM-UM003</a>	Describes how to use the dual-port EtherNet/IP adapter for PowerFlex 520-series drives for network communication.
PowerFlex 25-COMM-P PROFIBUS DPV1 Adapter User Manual, publication <a href="#">520COM-UM004</a>	Describes how to use the PROFIBUS DPV1 adapter for PowerFlex 520-series drives for network communication.
PowerFlex 520-series PROFINET Adapter User Manual, publication <a href="#">520COM-UM005</a>	Describes how to use the PROFINET adapter for PowerFlex 520-series drives for network communication.
PowerFlex Dynamic Braking Resistor Calculator Application Technique, publication <a href="#">PFLEX-AT001</a>	Provides information on dynamic braking and how to determine dynamic braking requirements.
Drives in Common Bus Configurations Application Technique, publication <a href="#">DRIVES-AT002</a>	Provide the necessary guidelines, considerations, and limitations for the proper application of PowerFlex drives used in common bus configurations.
Wiring and Grounding for Pulse Width Modulated (PWM) AC Drives Installation Instructions, publication <a href="#">DRIVES-IN001</a>	Describes how to install, protect, wire, and ground pulse-width modulated AC drives.
Preventive Maintenance Checklist of Industrial Control and Drive System Equipment Service Bulletin, publication <a href="#">DRIVES-TD001</a>	Provides a checklist and guidelines for performing preventive maintenance.
EtherNet/IP Network Devices User Manual, publication <a href="#">ENET-UM006</a>	Describes how to configure and use EtherNet/IP devices to communicate on the EtherNet/IP network.
Ethernet Reference Manual, publication <a href="#">ENET-RM002</a>	Describes basic Ethernet concepts, infrastructure components, and infrastructure features.
Safety Guidelines for the Application, Installation, and Maintenance of Solid-state Control, publication <a href="#">SGI-1.1</a>	Designed to harmonize with NEMA Standards Publication No. ICS 1.1-1987 and provides general guidelines for the application, installation, and maintenance of solid-state control in the form of individual devices or packaged assemblies incorporating solid-state components.
Industrial Automation Wiring and Grounding Guidelines, publication <a href="#">1770-4.1</a>	Provides general guidelines for installing a Rockwell Automation industrial system.
Product Selection and Configuration tools, <a href="http://rok.auto/systemtools">rok.auto/systemtools</a>	Helps configure complete, valid catalog numbers and build complete quotes based on detailed product information.
Rockwell Automation Global Short-circuit Current Ratings (SCCR) tool, <a href="http://rok.auto/sccr">rok.auto/sccr</a>	Provides coordinated high-fault branch circuit solutions for motor starters, soft starters, and component drives.
Product Certifications website, <a href="http://rok.auto/certifications">rok.auto/certifications</a>	Provides declarations of conformity, certificates, and other certification details.

**Notes:**



# Rockwell Automation Support

Use these resources to access support information.

<b>Technical Support Center</b>	Find help with how-to videos, FAQs, chat, user forums, Knowledgebase, and product notification updates.	<a href="http://rok.auto/support">rok.auto/support</a>
<b>Local Technical Support Phone Numbers</b>	Locate the telephone number for your country.	<a href="http://rok.auto/phonesupport">rok.auto/phonesupport</a>
<b>Technical Documentation Center</b>	Quickly access and download technical specifications, installation instructions, and user manuals.	<a href="http://rok.auto/techdocs">rok.auto/techdocs</a>
<b>Literature Library</b>	Find installation instructions, manuals, brochures, and technical data publications.	<a href="http://rok.auto/literature">rok.auto/literature</a>
<b>Product Compatibility and Download Center (PCDC)</b>	Download firmware, associated files (such as AOP, EDS, and DTM), and access product release notes.	<a href="http://rok.auto/pcdc">rok.auto/pcdc</a>

## Documentation Feedback

Your comments help us serve your documentation needs better. If you have any suggestions on how to improve our content, complete the form at [rok.auto/docfeedback](http://rok.auto/docfeedback).

Allen-Bradley, AppView, Compact I/O, Connected Components Workbench, CustomView, expanding human possibility, FactoryTalk, MainsFree, Micro800, PanelView, PointStop, PowerFlex, QuickView, Rockwell Automation, RSLogix 5000, RSNetWorx, StepLogic, Studio 5000 Logix Designer, and TechConnect are trademarks of Rockwell Automation, Inc.





EtherNet/IP and DeviceNet are trademarks of ODVA, Inc.

Microsoft Windows is a trademark of Microsoft Corporation.

Trademarks not belonging to Rockwell Automation are property of their respective companies.

Rockwell Automation maintains current product environmental compliance information on its website at [rok.auto/pec](http://rok.auto/pec).

Rockwell Otomasyon Ticaret A.Ş. Kar Plaza İş Merkezi E Blok Kat:6 34752, İçerenköy, İstanbul, Tel: +90 (216) 5698400 EEE Yönetmeliğine Uygundur

Connect with us.    

**rockwellautomation.com** — expanding **human possibility**<sup>®</sup>

AMERICAS: Rockwell Automation, 1201 South Second Street, Milwaukee, WI 53204-2496 USA, Tel: (1) 414.382.2000

EUROPE/MIDDLE EAST/AFRICA: Rockwell Automation NV, Pegasus Park, De Kleetlaan 12a, 1831 Diegem, Belgium, Tel: (32) 2663 0600

ASIA PACIFIC: Rockwell Automation SEA Pte Ltd, 2 Corporation Road, #04-05, Main Lobby, Corporation Place, Singapore 618494, Tel: (65) 6510 6608

UNITED KINGDOM: Rockwell Automation Ltd., Pitfield, Kiln Farm, Milton Keynes, MK11 3DR, United Kingdom, Tel: (44)(1908) 838-800

Publication 520-TD0011-EN-E - September 2025

Supersedes Publication 520-TD0011-EN-E - July 2024

Copyright © 2025 Rockwell Automation, Inc. All rights reserved.