

PowerFlex 750-Series AC Drives

Bulletin Numbers 20F, 20G, 21G

Topic	Page
Product Overview	3
Product Selection – PowerFlex 753	8
Product Selection – PowerFlex 753 Common Bus Drives	18
Product Selection – PowerFlex 755	25
Product Selection – PowerFlex 755 Common Bus Drives	40
PowerFlex 755 Floor Mount Drives for Open Frame Designs	51
Power Options for PowerFlex 755 Floor Mount, AC Input Drives	55
Connect to a CENTERLINE 2100 Motor Control Center (MCC)	59
Certifications and Specifications	60
Design Considerations	66
Fuse and Circuit Breaker Ratings	99
Cable Considerations	125
Motor Considerations	128
Dimensions and Weights	130
Drive Options	130
Additional Resources	215



Summary of Changes

This publication contains the following new or updated information. This list includes substantive updates only and is not intended to reflect all changes. Translated versions are not always available for each revision.

Topic	Page
Removed footnote for filtering option, this is no longer available	Throughout
Corrected catalog numbers	Front Cover
Updated catalog number explanation (letter g) as option a is no longer available	7
Corrected catalog numbers from 20F to 20G	37
Updated AC input over-voltage trip and bus over-voltage trip to include frame 10	63
Added 20-750-ENET2P dual-port Ethernet/IP optional module card	191...193
Updated information for 20-COMM-L as option is discontinued	191...193
Removed 1769-SM1 and 20-COMM-R as options are discontinued	191
Added XT feedback and safety option cards and the IMPORTANT statement related to safety card usage	195, 197
Removed 20-750-EMCKDK-1-F10 as option is unavailable	199
Updated transceiver options based EU and UK Ecodesign updates	201
Corrected 200 Hp line reactor catalog numbers	205
Corrected AR table to remove duplicate entries	215

The PowerFlex® 750-Series is a robust family of AC drives that provide ease of use, flexibility, and performance for various industrial applications. PowerFlex 753 drives provide general-purpose control for applications up to 400 Hp and 270 kW. PowerFlex 755 drives provide maximum flexibility and performance up to 2000 Hp and 1500 kW.

Maximize your productivity by taking advantage of these key features that are offered in the PowerFlex 750-Series drives:

- **DeviceLogix™** – Embedded control technology that supports the manipulation of discrete outputs and drive control functions, while using discrete inputs and drive status information on board the drive.
- **Predictive Diagnostics** – Tracks information that affects the life of the drive cooling fans and relay outputs. The drive can also be programmed to monitor the runtime hours for machine or motor bearings.
- **Option Cards** – Each drive has a slot-based architecture. Supported hardware control options are available for both products, to help reduce your inventory and spare parts requirements.
- **Safe Torque Off, Safe Speed Monitor, Integrated Safety - Safe Torque Off, and Integrated Safety Functions Option** – Provides a choice for safety levels depending on your application requirements.
- **Communication** – The PowerFlex 755 drives come with a built-in Ethernet port. Ethernet can easily be added to the PowerFlex 753 drives with a communication module.
- **I/O** – Option cards are available for additional analog and digital I/O. The PowerFlex 753 drives come with built-in I/O that can also be expanded with option cards.
- **Packaging** – Factory and field-installable enclosure options are available to meet most environmental requirements. Options include Open Type and flange mount to support cabinet mount requirements, extra protection wall-mount for harsh environments, and debris hoods and conduit plate kits.
- **Standard Power Structure** – A common power structure is shared to provide the same physical size and power range.



PowerFlex 750-Series Drive Family

This section provides a brief introduction to the different PowerFlex 750-Series drives.



Wall Mount Frames 1...7
IP00/IP20, NEMA/UL Type Open Drive
Includes a DC link choke on all Frames and internal brake transistor, standard on Frames 1...5, and optional on Frames 6 and 7.



Floor Mount Frames 8...10
IP20, NEMA/UL Type 1 Drive (2500 MCC style cabinet)
Includes a DC link choke, integrated AC line fuses, and roll-out design.
Hood that is shown on top of cabinets is optional. To order the hood, see [page 199](#) for information.



Floor Mount Frames 8...10
IP20, NEMA/UL Type 1 Drive with Options (2500 MCC style cabinet)
Includes a DC link choke, integrated AC line fuses, roll-out design, and option bay for control/protection devices.



Roll-out Design
(Frame 8 shown)
A roll-out cart is required for Frames 8...10 drives and Frame 9...10 option bay chassis. The roll-out cart has an adjustable curb height of 0...182 mm (0...7.2 in.) and curb offset/reach of 0...114 mm (0...4.5 in.).
See [page 200](#) for information to order the roll-out cart.

Catalog Number Explanation

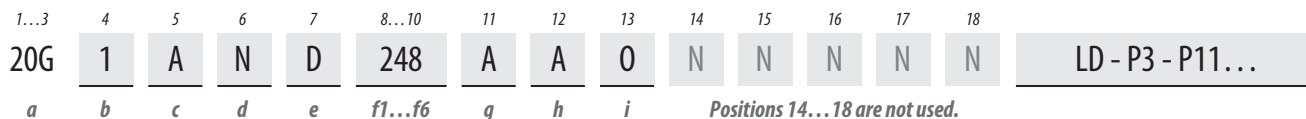

a

Drive		
Code	Type	Frames
20F	PowerFlex® 753	1...7
20G	PowerFlex 755	1...10
21G	PowerFlex 755 Drive with Options	8...10

b

Future Use		

c

Input Type		
Code	Description	Frames
1	AC Input with Precharge, includes DC Terminals	1...5 8...10
4	DC Input with Precharge	5...10
A	AC Input with Precharge, no DC Terminals	6...8 ⁽¹⁾

(1) The DC Bus Bar kit (20-750-DCBB1-Fx) is available for Frames 6...7 AC input drives that require DC bus terminals.

d

Enclosure		
Code	Description	Frames
R	IP20, NEMA/UL Type Open, Frame 1	1
F ⁽¹⁾	Flange (NEMA/UL Type 4X/12 back)	2...5
G	IP54, NEMA/UL Type 12	2...7
N ⁽²⁾	IP20/IP00, NEMA/UL Type Open	2...7
B ⁽³⁾	IP20, NEMA/UL Type 1, 600 mm (23.6 in.) Deep, Standard Cabinet Color (RAL 7032)	8...10
J ⁽³⁾	IP54, UL Type 12, 800 mm (31.5 in.) Deep, Standard Cabinet Color (RAL 7032)	8...10
K ⁽³⁾	IP54, NEMA 12, 2500 MCC Style Cabinet and Options w/MCC Power Bus, 800 mm (31.5 in.) Deep, Standard Cabinet Color (RAL 7032)	8...10
L ⁽³⁾	IP20, NEMA/UL Type 1, 800 mm (31.5 in.) Deep, Standard Cabinet Color (RAL 7032)	8...10
p ⁽³⁾	IP20, NEMA/UL Type 1, 2500 MCC Style Cabinet and Options w/MCC Power Bus, 800 mm (31.5 in.) Deep, Standard Cabinet Color (RAL 7032)	8...10
W ⁽³⁾	IP20, NEMA/UL Type 1, 2100 MCC Style Cabinet and Options w/MCC Power Bus, 800 mm (31.5 in.) Deep, CenterLine 2100 Gray (ASA49)	8...10
Y ⁽³⁾	IP54, NEMA 12, 2100 MCC Style Cabinet and Options w/MCC Power Bus, 800 mm (31.5 in.) Deep, CenterLine 2100 Gray (ASA49)	8...10
T	IP00, UL Open Type without Control POD	8...10

- (1) For Frames 6...7, a user installed flange kit (20-750-FLNG4-Fx) is available to convert a Code N drive that provides a NEMA/UL Type 4X/12 back.
- (2) Frames 2...5 are IP20, Frames 6...7 are IP00.
- (3) Available as a drive with options (21G).

e

Voltage Rating	
Code	Voltage
B	240V AC (208V AC) ⁽¹⁾ /325V DC (281V DC) ⁽¹⁾
C	400V AC/540V DC
D	480V AC/650V DC
E	600V AC/810V DC
F	690V AC/932V DC (not UL Listed)

(1) Drive must be programmed to obtain low (208V AC) voltage rating.

f1

ND Rating								
208V ⁽¹⁾ , 60 Hz Input								
Code	Amps	kW	Frame					
			Enclosure Code					
			B, J, L, T	F	G	N	K, P, W, Y	R
2P2	2.5	0.37						
4P2	4.8	0.75						
6P8	7.8	1.5		2	2	2		1
9P6	11	2.2						
015	17.5	4						
022	22	5.5						
028	32.2	7.5						
042	43	11		3	3	3		
054	60	15		4	4	4		
070	78.2	18.2		5	5	5		
080	92	22						
104	120	30						
130	150	37			6			
154	177	45		(2)		6		
192	221	55						
260	260	66						
312	359	90			7			
360	414	110		(2)		7		
477	477	132						

- (1) Drive must be programmed to obtain low (208VAC) voltage rating.
- (2) For Frames 6 and 7, a user-installed flange kit (20-750-FLNG4-Fx) is available to convert a Code N drive that provides a NEMA/UL Type 4X/12 back.

f2

ND Rating								
240V, 60 Hz Input								
Code	Amps	Hp	Frame					
			Enclosure Code					
			B, J, L, T	F	G	N	K, P, W, Y	R
2P2	2.2	0.5						
4P2	4.2	1						
6P8	6.8	2		2	2	2		1
9P6	9.6	3						
015	15.3	5						
022	22	7.5						
028	28	10						
042	42	15		3	3	3		
054	54	20		4	4	4		
070	70	25		5	5	5		
080	80	30						
104	104	40						
130	130	50						
154	154	60		(1)		6		
192	192	75						
260	260	100						
312	312	125						
360	360	150		(1)		7		
477	477	200						

(1) For Frames 6 and 7, a user-installed flange kit (20-750-FLNG4-Fx) is available to convert a Code N drive that provides a NEMA/UL Type 4X/12 back.

1...3 4 5 6 7 8...10 11 12 13 14 15 16 17 18
20G **1** **A** **N** **D** **248** **A** **A** **O** **N** **N** **N** **N** **N** **N** **N** **N** **N** **N** **LD - P3 - P11...**
a b c d e f1...f6 g h i Positions 14...18 are not used.

f3									
ND Rating									
400V, 50 Hz Input									
Code	Amps	kW	Frame						
			Enclosure Code						
			B, J, L, T	F	G	N	K, P, W, Y	R	
2P1	2.1	0.75							1
3P5	3.5	1.5							
5P0	5.0	2.2							
8P7	8.7	4		2	2	2			
011	11.5	5.5							
015	15.4	7.5							
022	22	11							
030	30	15							
037	37	18.5		3	3	3			
043	43	22							
060	60	30	-	4	4	4	-		
072	72	37			5				
085	85	45		5		5			
104	104	55							
140	140	75							
170	170	90			6				
205	205	110				6			
260	260	132		(1)					
302	302	160							
367	367	200			7				
456	456	250				7			
460	460	250	8	-	-	-	8 ⁽²⁾	-	
477	477	270	-	(1)	-	7	-		
540	540	315							
567	567	315							
650	650	355	8				8 ⁽²⁾		
750	750	400							
770	770	400							
910	910	500							
1K0	1040	560							
1K1	1090	630	9				9 ⁽²⁾		
1K2	1175	710							
1K4	1465	800							
1K5	1480	850							
1K6	1590	900							
2K1	2150	1250	10				10 ⁽²⁾		

(1) For Frames 6...7, a user installed flange kit (20-750-FLNG4-Fx) is available to convert a Code N drive that provides a NEMA/UL Type 4X/12 back.
 (2) Available as a drive with options (21G).

f4									
ND Rating									
480V, 60 Hz Input									
Code	Amps	Hp	Frame						
			Enclosure Code						
			B, J, L, T	F	G	N	K, P, W, Y	R	
2P1	2.1	1							
3P4	3.4	2							
5P0	5.0	3							
8P0	8.0	5							
011	11	7.5		2	2	2			1
014	14	10							
022	22	15							
027	27	20							
034	34	25		3	3	3			
040	40	30							
052	52	40	-	4	4	4	-		
065	65	50			5				
077	77	60		5		5			
096	96	75							
125	125	100							
156	156	125			6				
186	186	150							
248	248	200		(1)					
302	302	250							
361	361	300			7				
415	415	350				7			
430	430	350	8	-	-	-	8 ⁽²⁾	-	
477	477	400	-	(1)	-	7	-		
485	485	400							
545	545	450							
617	617	500	8				8 ⁽²⁾		
710	710	600							
740	740	650							
800	800	700							
960	960	800							
1K0	1045	900	9				9 ⁽²⁾		
1K2	1135	1000							
1K3	1365	1100							
1K4	1420	1250							
1K5	1525	1350							
2K0	2070	1750	10				10 ⁽²⁾		

(1) For Frames 6...7, a user installed flange kit (20-750-FLNG4-Fx) is available to convert a Code N drive that provides a NEMA/UL Type 4X/12 back.
 (2) Available as a drive with options (21G).

f5									
ND Rating									
600V, 60 Hz Input									
Code	Amps	Hp	Frame						
			Enclosure Code						
			B, J, L, T	F	G	N	K, P, W, Y	R	
1P7	1.7	1							
2P7	2.7	2							
3P9	3.9	3							
6P1	6.1	5							
9P0	9	7.5							
011	11	10							
012 ⁽¹⁾	12	10		-	6	6			
017	17	15		3	3	3			
018 ⁽¹⁾	18	15		-	6	6			
022	22	20		3	3	3			
023 ⁽¹⁾	23	20		-	6	6			
024 ⁽¹⁾	24	20							
027	27	25		4	4	4			
028 ⁽¹⁾	28	25	-	-	6	6	-		
032	32	30		4	4	4			
033 ⁽¹⁾	33	30		-	6	6			
041	41	40		5	5	5			
042 ⁽¹⁾	42	40		-	6	6			
052	52	50		5	-	5			
053 ⁽¹⁾	53	50							
063	63	60							
077	77	75							
099	99	100							
125	125	125		(2)		6	6		
144	144	150							
192	192	200							
242	242	250				7	7		
289	289	300							
295	295	300							
355	355	350							
395	395	400							
435	435	450	8						8 ⁽³⁾
460	460	500							
510	510	500							
595	595	600							
630	630	700							
760	760	800							
825	825	900							
900	900	950							
980	980	1000							
1K1	1110	1100							
1K4	1430	1400	10						10 ⁽³⁾

(1) Required for uncontrolled common DC bus applications. Optional for all AC applications.
 (2) For Frames 6...7, a user installed flange kit (20-750-FLNG4-Fx) is available to convert a Code N drive that provides a NEMA/UL Type 4X/12 back.
 (3) Available as a drive with options (21G).

1...3 4 5 6 7 8...10 11 12 13 14 15 16 17 18
20G 1 A N D 248 A A O N N N N N LD - P3 - P11...
 a b c d e f1...f6 g h i Positions 14...18 are not used.

ND Rating			Frame						
690V, 50 Hz Input (not UL Listed)			Enclosure Code						
Code	Amps	kW	B, J, L, T	F	G	N	K, P, W, Y	R	
			012	12	7.5				
015	15	11							
020	20	15							
023	23	18.5							
030	30	22							
034	34	30							
046	46	37			6	6			
050	50	45							
061	61	55							
082	82	75							
098	98	90							
119	119	110		(1)					
142	142	132							
171	171	160							
212	212	200			7	7			
263	263	250							
265	265	250							
330	330	315							
370	370	355							
415	415	400	8				8 ⁽²⁾		
460	460	450							
500	500	500							
590	590	560							
650	650	630							
710	710	710							
765	765	750							
795	795	800	9				9 ⁽²⁾		
960	960	900							
1K0	1040	1000							
1K4	1400	1400	10				10 ⁽²⁾		

- (1) For Frames 6...7, a user installed flange kit (20-750-FLNG4-Fx) is available to convert a Code N drive that provides a NEMA/UL Type 4X/12 back.
- (2) Available as a drive with options (21G).

Door Mounted HIM (Frames 8...10)	
Code	Operator Interface
0	No Door Mounted HIM
2	Enhanced LCD, Full Numeric, IP20
4	Enhanced LCD, Full Numeric, IP66 NEMA Type 4X/12

PowerFlex 755 w/Options (21G)
 Required Selections

Code	Option	Frames	Type
LD	Light Duty	8...10	System Overload Duty Cycle ⁽¹⁾
ND	Normal Duty		
HD	Heavy Duty		
P3	Input Thermal-magnetic Circuit Breaker	8...10	Power Disconnect ⁽¹⁾
P5	Input Non-Fused Molded Case Disconnect Switch	8 Only	
P14	Wiring Only Bay	8...10	Wiring Only Bay

(1) Only one option of this type can be selected.

PowerFlex 755 w/Options (21G)
 Additional Selections

Code	Option	Frames	Type
P11	Input Contactor	8 Only	Contactors ⁽¹⁾⁽²⁾
P12	Output Contactor		
L1	3% Input Reactor	8...9	Reactors ⁽¹⁾
L2	3% Output Reactor		
L3	5% Input Reactor	8 Only	
L4	5% Output Reactor		
P20	1200 A Bus	8...10	MCC Power Bus Capacity ⁽¹⁾
P22	2000 A Bus		
P24	3000 A Bus		
P30	UPS Control Bus, DC Input w/Precharge only	8...10	UPS Control Bus
X1	Auxiliary Transformer (500VA available), IP20 Cabinet Only	8 Only ⁽³⁾	Auxiliary Power

- (1) Only one option of this type can be selected.
- (2) Contactor options are not available for systems with MCC power bus.
- (3) Standard on all other cabinet configurations.

g

Filtering and CM Cap Configuration		
Code	Filtering	Default CM Cap Connection
A ⁽¹⁾	Yes	Jumper Removed
J	Yes	Jumper Installed

(1) No longer available.

h

Dynamic Braking ⁽¹⁾		
Code	Internal Resistor ⁽²⁾	Internal Transistor ⁽³⁾
A	No	Yes
N	No	No

- (1) Not available on Frames 8...10, specify Code 'N'.
- (2) Frames 1...2 only. Internal Resistor kits (20-750-DB1-Dx) sold separately.
- (3) Standard on Frames 1...5, optional on 6...7.

Product Selection – PowerFlex 753

200...240V AC, Three-phase Drives

IP00/IP20, NEMA/UL Type Open ⁽¹⁾

Normal Duty					Heavy Duty					Cat. No. ⁽²⁾	Frame Size
Output Amps: 240V (208V) ⁽³⁾			HP	kW	Output Amps: 240V (208V) ⁽³⁾			HP	kW		
Cont.	60 s	3 s			Cont.	60 s	3 s				
2.2 (2.5)	2.4 (2.7)	3.3 (3.7)	0.5	0.37	2.2 (2.5)	3.3 (3.7)	3.9 (4.5)	0.5	0.37	20F11RB2P2JA0NNNNN	1
4.2 (4.8)	4.6 (5.2)	6.3 (7.2)	1	0.75	2.2 (2.5)	4.6 (5.2)	6.3 (7.2)	0.5	0.37	20F11RB4P2JA0NNNNN	
6.8 (7.8)	7.4 (8.5)	10.2 (11.7)	2	1.5	4.2 (4.8)	7.4 (8.5)	10.2 (11.7)	1	0.75	20F11RB6P8JA0NNNNN	
9.6 (11)	10.5 (12.1)	14.4 (16.5)	3	2.2	6.8 (7.8)	10.5 (12.1)	14.4 (16.5)	2	1.5	20F11RB9P6JA0NNNNN	
15.3 (15.3)	16.8 (16.8)	22.9 (22.9)	5	4	9.6 (11)	16.8 (16.8)	22.9 (22.9)	3	2.2	20F11RB015JA0NNNNN	
2.2 (2.5)	3.3 (3.7)	3.9 (4.5)	0.5	0.37	2.2 (2.5)	3.3 (3.7)	3.9 (4.5)	0.5	0.37	20F11NB2P2JA0NNNNN	2
4.2 (4.8)	6.3 (7.2)	7.5 (8.6)	1	0.75	4.2 (4.8)	6.3 (7.2)	7.5 (8.6)	1	0.75	20F11NB4P2JA0NNNNN	
6.8 (7.8)	10.2 (11.7)	12.2 (14)	2	1.5	6.8 (7.8)	10.2 (11.7)	12.2 (14)	2	1.5	20F11NB6P8JA0NNNNN	
9.6 (11)	14.4 (16.5)	17.2 (19.8)	3	2.2	9.6 (11)	14.4 (16.5)	17.2 (19.8)	3	2.2	20F11NB9P6JA0NNNNN	
15.3 (17.5)	16.8 (19.2)	22.9 (26.2)	5	4	9.6 (11)	16.8 (19.2)	22.9 (26.2)	3	2.2	20F11NB015JA0NNNNN	
22 (22)	24.2 (24.2)	33 (33)	7.5	5.5	15.3 (17.5)	24.2 (24.2)	33 (33)	5	4	20F11NB022JA0NNNNN	3
28 (32.2)	30.8 (35.4)	42 (48.3)	10	7.5	22 (22)	33 (35.4)	42 (48.3)	7.5	5.5	20F11NB028JA0NNNNN	
42 (43)	46.2 (47.3)	63 (64.5)	15	11	28 (32.2)	46.2 (48.3)	63 (64.5)	10	7.5	20F11NB042JA0NNNNN	
54 (60)	59.4 (66)	81 (90)	20	15	42 (43)	63 (64.5)	81 (90)	15	11	20F11NB054JA0NNNNN	
70 (78.2)	77 (86)	105 (117)	25	18.5	54 (60)	81 (90)	105 (117)	20	15	20F11NB070JA0NNNNN	
80 (92)	88 (101)	120 (138)	30	22	70 (78.2)	105 (117)	126 (140)	25	18.5	20F11NB080JA0NNNNN	4
104 (120)	114 (132)	156 (180)	40	30	80 (92)	120 (138)	156 (180)	30	22	20F11NB104JNONNNNN ⁽⁴⁾	
130 (150)	143 (165)	195 (225)	50	37	104 (120)	156 (180)	195 (225)	40	30	20F11NB130JNONNNNN ⁽⁴⁾	
154 (177)	169 (194)	231 (265)	60	45	130 (150)	195 (225)	234 (270)	50	37	20F11NB154JNONNNNN ⁽⁴⁾	
192 (221)	211 (243)	288 (331)	75	55	154 (177)	231 (265)	288 (331)	60	45	20F11NB192JNONNNNN ⁽⁴⁾	
260 (260)	286 (286)	390 (390)	100	66	192 (221)	288 (331)	390 (390)	75	55	20F11NB260JNONNNNN ⁽⁴⁾	5
312 (359)	343 (394)	468 (538)	125	90	260 (260)	390 (394)	468 (538)	100	66	20F11NB312JNONNNNN ⁽⁴⁾	
360 (414)	396 (455)	540 (621)	150	110	312 (359)	468 (538)	561 (646)	125	90	20F11NB360JNONNNNN ⁽⁴⁾	
477 (477)	524 (524)	715 (715)	200	132	312 (359)	468 (538)	561 (646)	125	90	20F11NB477JNONNNNN ⁽⁴⁾	

- (1) Frames 1...5 are IP20, NEMA/UL Type Open. Frames 6...7 are IP00, NEMA/UL Type Open. Frames 1...7 can be converted to IP20, NEMA/UL Type 1 with optional kit (20-750-NEMA1-Fx), where x is the frame size.
- (2) The 5th character determines Input Type; "T" = AC input with precharge and DC terminals, and "A" = AC input with precharge and no DC terminals. For DC input drives, see [DRIVES-5G001](#), the PowerFlex Common Bus Configuration Selection Guide.
- (3) Drive must be programmed to lower voltage to obtain the currents shown in parentheses.
- (4) The 12th character determines whether an internal dynamic braking IGBT is included; "A" = Internal dynamic braking transistor installed, and "N" = No internal dynamic braking transistor.

200...240V AC, Three-phase Drives (Continued)

IP54, NEMA/UL Type 12

Normal Duty					Heavy Duty					Cat. No. ⁽¹⁾	Frame Size
Output Amps: 240V (208V) ⁽²⁾			HP	kW	Output Amps: 240V (208V) ⁽²⁾			HP	kW		
Cont.	60 s	3 s			Cont.	60 s	3 s				
2.2 (2.5)	3.3 (3.8)	4 (4.5)	0.5	0.37	2.2 (2.5)	3.3 (3.7)	3.9 (4.5)	0.5	0.37	20F11GB2P2JA0NNNNN	2
4.2 (4.8)	6.3 (7.2)	7.5 (8.6)	1	0.75	4.2 (4.8)	6.3 (7.2)	7.5 (8.6)	1	0.75	20F11GB4P2JA0NNNNN	
6.8 (7.8)	10.2 (11.7)	12.2 (14)	2	1.5	6.8 (7.8)	10.2 (11.7)	12.2 (14)	2	1.5	20F11GB6P8JA0NNNNN	
9.6 (11)	14.4 (16.5)	17.2 (19.8)	3	2.2	9.6 (11)	14.4 (16.5)	17.2 (19.8)	3	2.2	20F11GB9P6JA0NNNNN	
15.3 (17.5)	16.8 (19.2)	22.9 (26.2)	5	4	9.6 (11)	16.8 (19.2)	22.9 (26.2)	3	2.2	20F11GB015JA0NNNNN	
22 (22)	24.2 (24.2)	33 (33)	7.5	5.5	15.3 (17.5)	24.2 (24.2)	33 (33)	5	4	20F11GB022JA0NNNNN	3
28 (32.2)	30.8 (35.4)	42 (48.3)	10	7.5	22 (22)	33 (35.4)	42 (48.3)	7.5	5.5	20F11GB028JA0NNNNN	
42 (43)	46.2 (47.3)	63 (64.5)	15	11	28 (32.2)	46.2 (48.3)	63 (64.5)	10	7.5	20F11GB042JA0NNNNN	
54 (60)	59.4 (66)	81 (90)	20	15	42 (43)	63 (64.5)	81 (90)	15	11	20F11GB054JA0NNNNN	

IP54, NEMA/UL Type 12 (Continued)

Normal Duty					Heavy Duty					Cat. No. (1)	Frame Size
Output Amps: 240V (208V) (2)			HP	kW	Output Amps: 240V (208V) (2)			HP	kW		
Cont.	60 s	3 s			Cont.	60 s	3 s				
70 (78.2)	77 (86)	105 (117)	25	18.5	54 (60)	81 (90)	105 (117)	20	15	20F11GB070JA0NNNNN	5
80 (92)	88 (101)	120 (138)	30	22	70 (78.2)	105 (117)	126 (140)	25	18.5	20F1AGB080JNONNNNN (3)	6
104 (120)	114 (132)	156 (180)	40	30	80 (92)	120 (138)	156 (180)	30	22	20F1AGB104JNONNNNN (3)	
130 (150)	143 (165)	195 (225)	50	37	104 (120)	156 (180)	195 (225)	40	30	20F1AGB130JNONNNNN (3)	
154 (177)	169 (194)	231 (265)	60	45	130 (150)	195 (225)	234 (270)	50	37	20F1AGB154JNONNNNN (3)	
192 (221)	211 (243)	288 (331)	75	55	154 (177)	231 (265)	288 (331)	60	45	20F1AGB192JNONNNNN (3)	
260 (260)	286 (286)	390 (390)	100	66	192 (221)	288 (331)	390 (390)	75	55	20F1AGB260JNONNNNN (3)	7
312 (359)	343 (394)	468 (538)	125	90	260 (260)	390 (394)	468 (538)	100	66	20F1AGB312JNONNNNN (3)	
360 (414)	396 (455)	540 (621)	150	110	312 (359)	468 (538)	561 (646)	125	90	20F1AGB360JNONNNNN (3)	

(1) The 5th character determines Input Type; "T" = AC input with precharge and DC terminals, and "A" = AC input with precharge and no DC terminals. For DC input drives, see [DRIVES-56001](#), the PowerFlex Common Bus Configuration Selection Guide.

(2) Drive must be programmed to lower voltage to obtain the currents shown in parentheses.

(3) The 12th character determines whether an internal dynamic braking IGBT is included; "A" = Internal dynamic braking transistor installed, and "N" = No internal dynamic braking transistor.

200...240V AC, Three-phase Drives (Continued)

Note: Frame 6...7 IP00, NEMA Type Open drives can be converted to a flange mount drive (Back/Heatsink: IP66, NEMA/UL Type 4X) with an optional user installed flange kit (kit 20-750-FLNG4-F6 for Frame 6, and kit 20-750-FLNG4-F7 for Frame 7). See page 8 for 200...240V, Frame 6...7 IP00, NEMA Type Open drives.

Flange Mount (Front: IP20, NEMA/UL Type Open; Back/Heatsink: IP66, NEMA/UL Type 4X)

Normal Duty					Heavy Duty					Cat. No. (1)	Frame Size
Output Amps: 240V (208V) (2)			HP	kW	Output Amps: 240V (208V) (2)			HP	kW		
Cont.	60 s	3 s			Cont.	60 s	3 s				
2.2 (2.5)	3.3 (3.7)	3.9 (4.5)	0.5	0.37	2.2 (2.5)	3.3 (3.7)	3.9 (4.5)	0.5	0.37	20F11FB2P2JA0NNNNN	2
4.2 (4.8)	6.3 (7.2)	7.5 (8.6)	1	0.75	4.2 (4.8)	6.3 (7.2)	7.5 (8.6)	1	0.75	20F11FB4P2JA0NNNNN	
6.8 (7.8)	10.2 (11.7)	12.2 (14)	2	1.5	6.8 (7.8)	10.2 (11.7)	12.2 (14)	2	1.5	20F11FB6P8JA0NNNNN	
9.6 (11)	14.4 (16.5)	17.2 (19.8)	3	2.2	9.6 (11)	14.4 (16.5)	17.2 (19.8)	3	2.2	20F11FB9P6JA0NNNNN	
15.3 (17.5)	16.8 (19.2)	22.9 (26.2)	5	4	9.6 (11)	16.8 (19.2)	22.9 (26.2)	3	2.2	20F11FB015JA0NNNNN	
22 (22)	24.2 (24.2)	33 (33)	7.5	5.5	15.3 (17.5)	24.2 (24.2)	33 (33)	5	4	20F11FB022JA0NNNNN	3
28 (32.2)	30.8 (35.4)	42 (48.3)	10	7.5	22 (22)	33 (35.4)	42 (48.3)	7.5	5.5	20F11FB028JA0NNNNN	
42 (43)	46.2 (47.3)	63 (64.5)	15	11	28 (32.2)	46.2 (48.3)	63 (64.5)	10	7.5	20F11FB042JA0NNNNN	
54 (60)	59.4 (66)	81 (90)	20	15	42 (43)	63 (64.5)	81 (90)	15	11	20F11FB054JA0NNNNN	4
70 (78.2)	77 (86)	105 (117)	25	18.5	54 (60)	81 (90)	105 (117)	20	15	20F11FB070JA0NNNNN	5
80 (92)	88 (101)	120 (138)	30	22	70 (78.2)	105 (117)	126 (140)	25	18.5	20F11FB080JA0NNNNN	

(1) The 5th character determines Input Type; "T" = AC input with precharge and DC terminals, and "A" = AC input with precharge and no DC terminals. For DC input drives, see [DRIVES-56001](#), the PowerFlex Common Bus Configuration Selection Guide.

(2) Drive must be programmed to lower voltage to obtain the currents shown in parentheses.

380...400V AC, Three-phase Drives

IP00/IP20, NEMA/UL Type Open ⁽¹⁾

Normal Duty				Heavy Duty				Cat. No. ⁽²⁾	Frame Size
Output Amps			kW	Output Amps			kW		
Cont.	60 s	3 s		Cont.	60 s	3 s			
2.1	2.3	3.2	0.75	1.3	2.3	3.2	0.37	20F11RC2P1JA0NNNNN	1
3.5	3.9	5.3	1.5	2.1	3.9	5.3	0.75	20F11RC3P5JA0NNNNN	
5	5.5	7.5	2.2	3.5	5.5	7.5	1.5	20F11RC5P0JA0NNNNN	
8.7	9.6	13.1	4	5	9.6	13.1	2.2	20F11RC8P7JA0NNNNN	
11.5	13.1	17.3	5.5	8.7	13.1	17.3	4	20F11RC011JA0NNNNN	
15.4	16.9	23.1	7.5	11.5	17.2	23.1	5.5	20F11RC015JA0NNNNN	
2.1	3.1	3.7	0.75	2.1	3.1	3.7	0.75	20F11NC2P1JA0NNNNN	2
3.5	5.2	6.3	1.5	3.5	5.2	6.3	1.5	20F11NC3P5JA0NNNNN	
5	7.5	9	2.2	5	7.5	9	2.2	20F11NC5P0JA0NNNNN	
8.7	13	15.6	4	8.7	13.0	15.6	4	20F11NC8P7JA0NNNNN	
11.5	17.2	20.7	5.5	11.5	17.2	20.7	5.5	20F11NC011JA0NNNNN	
15.4	16.9	23.1	7.5	11.5	17.2	20.7	5.5	20F11NC015JA0NNNNN	
22	24.2	33	11	15.4	24.2	33	7.5	20F11NC022JA0NNNNN	3
30	33	45	15	22	33	45	11	20F11NC030JA0NNNNN	
37	40.7	55.5	18.5	30	45	55.5	15	20F11NC037JA0NNNNN	
43	47.3	64.5	22	37	55.5	66.6	18.5	20F11NC043JA0NNNNN	
60	66	90	30	43	66	90	22	20F11NC060JA0NNNNN	
72	79.2	108	37	60	90	108	30	20F11NC072JA0NNNNN	
85	93.5	128	45	72	108	130	37	20F11NC085JA0NNNNN	4
104	114	156	55	85	128	156	45	20F11NC104JA0NNNNN	
140	154	210	75	104	156	210	55	20F11NC140JNONNNNN ⁽³⁾	5
170	187	255	90	140	210	255	75	20F11NC170JNONNNNN ⁽³⁾	
205	226	308	110	170	255	308	90	20F11NC205JNONNNNN ⁽³⁾	6
260	286	390	132	205	308	390	110	20F11NC260JNONNNNN ⁽³⁾	
302	332	453	160	260	390	468	132	20F11NC302JNONNNNN ⁽³⁾	7
367	404	551	200	302	453	551	160	20F11NC367JNONNNNN ⁽³⁾	
456	502	684	250	367	551	684	200	20F11NC456JNONNNNN ⁽³⁾	
477	525	716	270	367	551	684	200	20F11NC477JNONNNNN ⁽³⁾	

(1) Frames 1...5 are IP20, NEMA/UL Type Open. Frames 6...7 are IP00, NEMA/UL Type Open. Frames 1...7 can be converted to IP20, NEMA/UL Type 1 with optional kit (20-750-NEMA1-Fx), where x is the frame size.

(2) The 5th character determines Input Type; "I" = AC input with precharge and DC terminals, and "A" = AC input with precharge and no DC terminals. For DC input drives, see [DRIVES-S6001](#), the PowerFlex Common Bus Configuration Selection Guide.

(3) The 12th character determines whether an internal dynamic braking IGBT is included; "A" = Internal dynamic braking transistor installed, and "N" = No internal dynamic braking transistor.

380...400V AC, Three-phase Drives (Continued)

IP54, NEMA/UL Type 12

Normal Duty				Heavy Duty				Cat. No. ⁽¹⁾	Frame Size
Output Amps			kW	Output Amps			kW		
Cont.	60 s	3 s		Cont.	60 s	3 s			
2.1	3.1	3.7	0.75	2.1	3.1	3.7	0.75	20F11GC2P1JA0NNNNN	2
3.5	5.2	6.3	1.5	3.5	5.2	6.3	1.5	20F11GC3P5JA0NNNNN	
5	7.5	9	2.2	5	7.5	9	2.2	20F11GC5P0JA0NNNNN	
8.7	13	15.6	4	8.7	13	15.6	4	20F11GC8P7JA0NNNNN	
11.5	17.2	20.7	5.5	11.5	17.2	20.7	5.5	20F11GC011JA0NNNNN	
15.4	16.9	23.1	7.5	11.5	17.2	20.7	5.5	20F11GC015JA0NNNNN	
22	24.2	33	11	15.4	24.2	33	7.5	20F11GC022JA0NNNNN	

IP54, NEMA/UL Type 12 (Continued)

Normal Duty				Heavy Duty				Cat. No. (1)	Frame Size
Output Amps			kW	Output Amps			kW		
Cont.	60 s	3 s		Cont.	60 s	3 s			
30	33	45	15	22	33	45	11	20F11GC030JA0NNNNN	3
37	40.7	55.5	18.5	30	45	55.5	15	20F11GC037JA0NNNNN	
43	47.3	64.5	22	37	55.5	66.6	18.5	20F11GC043JA0NNNNN	
60	66	90	30	43	66	90	22	20F11GC060JA0NNNNN	4
72	79.2	108	37	60	90	108	30	20F11GC072JA0NNNNN	5
85	93.5	128	45	72	108	130	37	20F11GC085JA0NNNNN	
104	114	156	55	85	128	156	45	20F11AGC104JNONNNNN (2)	6
140	154	210	75	104	156	210	55	20F11AGC140JNONNNNN (2)	
170	187	255	90	140	210	255	75	20F11AGC170JNONNNNN (2)	
205	226	308	110	170	255	308	90	20F11AGC205JNONNNNN (2)	7
260	286	390	132	205	308	390	110	20F11AGC260JNONNNNN (2)	
302	332	453	160	260	390	468	132	20F11AGC302JNONNNNN (2)	
367	404	551	200	302	453	551	160	20F11AGC367JNONNNNN (2)	7
456	502	684	250	367	551	684	200	20F11AGC456JNONNNNN (2)	

(1) The 5th character determines Input Type; "T" = AC input with precharge and DC terminals, and "A" = AC input with precharge and no DC terminals. For DC input drives, see [DRIVES-56001](#), the PowerFlex Common Bus Configuration Selection Guide.

(2) The 12th character determines whether an internal dynamic braking IGBT is included; "A" = Internal dynamic braking transistor installed, and "N" = No internal dynamic braking transistor.

380...400V AC, Three-phase Drives (Continued)

Note: Frame 6...7 IP00, NEMA Type Open drives can be converted to a flange mount drive (back/heatsink: IP66, NEMA/UL Type 4X) with an optional user installed flange kit (kit 20-750-FLNG4-F6 for Frame 6, and kit 20-750-FLNG4-F7 for Frame 7). See page [10](#) for 380...400V, Frame 6...7 IP00, NEMA Type Open drives.

Flange Mount (Front: IP20, NEMA/UL Type Open; Back/Heatsink: IP66, NEMA/UL Type 4X)

Normal Duty				Heavy Duty				Cat. No. (1)	Frame Size
Output Amps			kW	Output Amps			kW		
Cont.	60 s	3 s		Cont.	60 s	3 s			
2.1	3.1	3.7	0.75	2.1	3.1	3.7	0.75	20F11FC2P1JA0NNNNN	2
3.5	5.2	6.3	1.5	3.5	5.2	6.3	1.5	20F11FC3P5JA0NNNNN	
5	7.5	9	2.2	5	7.5	9	2.2	20F11FC5P0JA0NNNNN	
8.7	13	15.6	4	8.7	13	15.6	4	20F11FC8P7JA0NNNNN	
11.5	17.2	20.7	5.5	11.5	17.2	20.7	5.5	20F11FC011JA0NNNNN	
15.4	16.9	23.1	7.5	11.5	17.2	20.7	5.5	20F11FC015JA0NNNNN	
22	24.2	33	11	15.4	24.2	33	7.5	20F11FC022JA0NNNNN	
30	33	45	15	22	33	45	11	20F11FC030JA0NNNNN	3
37	40.7	55.5	18.5	30	45	55.5	15	20F11FC037JA0NNNNN	
43	47.3	64.5	22	37	55.5	66.6	18.5	20F11FC043JA0NNNNN	
60	66	90	30	43	66	90	22	20F11FC060JA0NNNNN	4
72	79.2	108	37	60	90	108	30	20F11FC072JA0NNNNN	5
85	93.5	128	45	72	108	130	37	20F11FC085JA0NNNNN	
104	114	156	55	85	128	156	45	20F11FC104JA0NNNNN	

(1) The 5th character determines Input Type; "T" = AC input with precharge and DC terminals, and "A" = AC input with precharge and no DC terminals. For DC input drives, see [DRIVES-56001](#), the PowerFlex Common Bus Configuration Selection Guide.

460...480V AC, Three-phase Drives

IP00/IP20, NEMA/UL Type Open ⁽¹⁾

Normal Duty				Heavy Duty				Cat. No. ⁽²⁾	Frame Size
Output Amps			Hp	Output Amps			Hp		
Cont.	60 s	3 s		Cont.	60 s	3 s			
2.1	2.3	3.2	1	1.1	2.3	3.2	0.5	20F11RD2P1JAONNNNN	1
3.4	3.7	5.1	2	2.8	4.2	5.1	1	20F11RD3P4JAONNNNN	
5	5.5	7.5	3	3.4	5.5	7.5	2	20F11RD5P0JAONNNNN	
8	8.8	12	5	5	8.8	12	3	20F11RD8P0JAONNNNN	
11	12.1	16.5	7.5	8	12.1	16.5	5	20F11RD011JAONNNNN	
14	15.4	21	10	11	16.5	21	7.5	20F11RD014JAONNNNN	
2.1	3.1	3.7	1	2.1	3.1	3.7	1	20F11ND2P1JAONNNNN	2
3.4	5.1	6.1	2	3.4	5.1	6.1	2	20F11ND3P4JAONNNNN	
5	7.5	9	3	5	7.5	9	3	20F11ND5P0JAONNNNN	
8	12	14.4	5	8	12	14.4	5	20F11ND8P0JAONNNNN	
11	16.5	19.8	7.5	11	16.5	19.8	7.5	20F11ND011JAONNNNN	
14	15.4	21	10	11	16.5	21	7.5	20F11ND014JAONNNNN	
22	24.2	33	15	14	24.2	33	10	20F11ND022JAONNNNN	3
27	29.7	40.5	20	22	33	40.5	15	20F11ND027JAONNNNN	
34	37.4	51	25	27	40.5	51	20	20F11ND034JAONNNNN	
40	44	60	30	34	51	61.2	25	20F11ND040JAONNNNN	
52	57.2	78	40	40	60	78	30	20F11ND052JAONNNNN	
65	71.5	97.5	50	52	78	97.5	40	20F11ND065JAONNNNN	
77	84.7	116	60	65	97.5	116	50	20F11ND077JAONNNNN	4
96	106	144	75	77	116	144	60	20F11ND096JAONNNNN	
125	138	188	100	96	144	188	75	20F1AND125JNONNNNN ⁽³⁾	5
156	172	234	125	125	188	234	100	20F1AND156JNONNNNN ⁽³⁾	
186	205	279	150	156	234	281	125	20F1AND186JNONNNNN ⁽³⁾	6
248	273	372	200	186	279	372	150	20F1AND248JNONNNNN ⁽³⁾	
302	332	453	250	248	372	453	200	20F1AND302JNONNNNN ⁽³⁾	7
361	397	542	300	302	453	535	250	20F1AND361JNONNNNN ⁽³⁾	
415	457	623	350	361	542	650	300	20F1AND415JNONNNNN ⁽³⁾	
477	525	716	400	361	542	650	300	20F1AND477JNONNNNN ⁽³⁾	

(1) Frames 1...5 are IP20, NEMA/UL Type Open. Frames 6...7 are IP00, NEMA/UL Type Open. Frames 1...7 can be converted to IP20, NEMA/UL Type 1 with optional kit (20-750-NEMA1-Fx), where x is the frame size.

(2) The 5th character determines Input Type; "I" = AC input with precharge and DC terminals, and "A" = AC input with precharge and no DC terminals. For DC input drives, see [DRIVES-SG001](#), the PowerFlex Common Bus Configuration Selection Guide.

(3) The 12th character determines whether an internal dynamic braking IGBT is included; "A" = Internal dynamic braking transistor installed, and "N" = No internal dynamic braking transistor.

460...480V AC, Three-phase Drives (Continued)

IP54, NEMA/UL Type 12

Normal Duty				Heavy Duty				Cat. No. ⁽¹⁾	Frame Size
Output Amps			Hp	Output Amps			Hp		
Cont.	60 s	3 s		Cont.	60 s	3 s			
2.1	3.1	3.7	1	2.1	3.1	3.7	1	20F11GD2P1JAONNNNN	2
3.4	5.1	6.1	2	3.4	5.1	6.1	2	20F11GD3P4JAONNNNN	
5	7.5	9	3	5	7.5	9	3	20F11GD5P0JAONNNNN	
8	12	14.4	5	8	12	14.4	5	20F11GD8P0JAONNNNN	
11	16.5	19.8	7.5	11	16.5	19.8	7.5	20F11GD011JAONNNNN	
14	15.4	21	10	11	16.5	21	7.5	20F11GD014JAONNNNN	
22	24.2	33	15	14	24.2	33	10	20F11GD022JAONNNNN	

IP54, NEMA/UL Type 12 (Continued)

Normal Duty				Heavy Duty				Cat. No. (1)	Frame Size
Output Amps			Hp	Output Amps			Hp		
Cont.	60 s	3 s		Cont.	60 s	3 s			
27	29.7	40.5	20	22	33	40.5	15	20F11GD027JA0NNNNN	3
34	37.4	51	25	27	40.5	51	20	20F11GD034JA0NNNNN	
40	44	60	30	34	51	61.2	25	20F11GD040JA0NNNNN	
52	57.2	78	40	40	60	78	30	20F11GD052JA0NNNNN	4
65	71.5	97.5	50	52	78	97.5	40	20F11GD065JA0NNNNN	5
77	84.7	116	60	65	97.5	116	50	20F11GD077JA0NNNNN	
96	106	144	75	77	116	144	60	20F11AGD096JN0NNNNN (2)	6
125	138	188	100	96	144	188	75	20F11AGD125JN0NNNNN (2)	
156	172	234	125	125	188	234	100	20F11AGD156JN0NNNNN (2)	
186	205	279	150	156	234	281	125	20F11AGD186JN0NNNNN (2)	7
248	273	372	200	186	279	372	150	20F11AGD248JN0NNNNN (2)	
302	332	453	250	248	372	453	200	20F11AGD302JN0NNNNN (2)	
361	397	542	300	302	453	535	250	20F11AGD361JN0NNNNN (2)	7
415	457	623	350	361	542	650	300	20F11AGD415JN0NNNNN (2)	

(1) The 5th character determines Input Type; "T" = AC input with precharge and DC terminals, and "A" = AC input with precharge and no DC terminals. For DC input drives, see [DRIVES-56001](#), the PowerFlex Common Bus Configuration Selection Guide.

(2) The 12th character determines whether an internal dynamic braking IGBT is included; "A" = Internal dynamic braking transistor installed, and "N" = No internal dynamic braking transistor.

460...480V AC, Three-phase Drives (Continued)

Note: Frame 6...7 IP00, NEMA Type Open drives can be converted to a flange mount drive (back/heatsink: IP66, NEMA/UL Type 4X) with an optional user installed flange kit (kit 20-750-FLNG4-F6 for Frame 6, and kit 20-750-FLNG4-F7 for Frame 7). See page [12](#) for 480V, Frame 6...7 IP00, NEMA Type Open drives.

Flange Mount (Front: IP20, NEMA/UL Type Open; Back/Heatsink: IP66, NEMA/UL Type 4X)

Normal Duty				Heavy Duty				Cat. No. (1)	Frame Size
Output Amps			Hp	Output Amps			Hp		
Cont.	60 s	3 s		Cont.	60 s	3 s			
2.1	3.1	3.7	1	2.1	3.1	3.7	1	20F11FD2P1JA0NNNNN	2
3.4	5.1	6.1	2	3.4	5.1	6.1	2	20F11FD3P4JA0NNNNN	
5	7.5	9	3	5	7.5	9.0	3	20F11FD5P0JA0NNNNN	
8	12	14.4	5	8	12	14.4	5	20F11FD8P0JA0NNNNN	
11	16.5	19.8	7.5	11	16.5	19.8	7.5	20F11FD011JA0NNNNN	
14	15.4	21	10	11	16.5	21	7.5	20F11FD014JA0NNNNN	
22	24.2	33	15	14	24.2	33	10	20F11FD022JA0NNNNN	
27	29.7	40.5	20	22	33	40.5	15	20F11FD027JA0NNNNN	3
34	37.4	51	25	27	40.5	51	20	20F11FD034JA0NNNNN	
40	44	60	30	34	51	61.2	25	20F11FD040JA0NNNNN	
52	57.2	78	40	40	60	78	30	20F11FD052JA0NNNNN	4
65	71.5	97.5	50	52	78	97.5	40	20F11FD065JA0NNNNN	5
77	84.7	116	60	65	97.5	116	50	20F11FD077JA0NNNNN	
96	106	144	75	77	116	144	60	20F11FD096JA0NNNNN	

(1) The 5th character determines Input Type; "T" = AC input with precharge and DC terminals, and "A" = AC input with precharge and no DC terminals. For DC input drives, see [DRIVES-56001](#), the PowerFlex Common Bus Configuration Selection Guide.

575...600V AC, Three-phase Drives

Frames 3, 4, and 5 are only 575...600V AC drives. Frames 6 and 7 are dual-voltage drives, and can be operated at 575...600V or 660...690V AC.

Important: Frames 3, 4, and 5 must not be used in common DC input-sharing applications with Frames 6 or larger drives. For more details, contact your local Rockwell Automation sales office or your Allen-Bradley distributor.

IP00/IP20, NEMA/UL Type Open ⁽¹⁾

Normal Duty				Heavy Duty				Cat. No. ⁽²⁾	Frame Size	
Output Amps			Hp	Output Amps			Hp			
Cont.	60 s	3 s		Cont.	60 s	3 s				
1.7	1.9	2.6	1	1.7	1.4	2.6	1	20FT1NE1P7JAONNNNN	3	
2.7	3	4.1	2	1.7	2.6	4.1	1	20FT1NE2P7JAONNNNN		
3.9	4.29	5.85	3	2.7	4.1	5.9	2	20FT1NE3P9JAONNNNN		
6.1	6.7	9.2	5	3.9	5.9	9.2	3	20FT1NE6P1JAONNNNN		
9	9.9	13.5	7.5	6.1	9.2	13.5	5	20FT1NE9P0JAONNNNN		
11	12.1	16.5	10	9	13.5	16.5	7.5	20FT1NE01JAONNNNN		
17	18.7	25.5	15	11	16.5	25.5	10	20FT1NE017JAONNNNN		
22	24.2	33	20	17	25.5	33	15	20FT1NE022JAONNNNN	4	
27	29.7	40.5	25	22	33	40.5	20	20FT1NE027JAONNNNN		
32	35.2	48	30	27	40.5	48.6	25	20FT1NE032JAONNNNN	5	
41	45.1	61.5	40	32	48	61.5	30	20FT1NE04JAONNNNN		
52	57.2	78	50	41	61.5	78	40	20FT1NE052JAONNNNN	6	
12	13.2	18	10	9.1	13.7	18	7.5	20F1ANE012JNONNNNN ⁽³⁾		
18	19.8	27	15	12	18	27	10	20F1ANE018JNONNNNN ⁽³⁾		
23	25.3	34.5	20	18	27	34.5	15	20F1ANE023JNONNNNN ⁽³⁾		
24	26.4	36	20	22	33	39.6	20	20F1ANE024JNONNNNN ⁽³⁾		
28	30.8	42	25	23	34.5	42	20	20F1ANE028JNONNNNN ⁽³⁾		
33	36.3	49.5	30	28	42	50.4	25	20F1ANE033JNONNNNN ⁽³⁾		
42	46.2	63	40	33	49.5	63	30	20F1ANE042JNONNNNN ⁽³⁾		
53	58	80	50	42	63	80	40	20F1ANE053JNONNNNN ⁽³⁾		
63	69	95	60	52	78	95	50	20F1ANE063JNONNNNN ⁽³⁾		
77	85	116	75	63	95	116	60	20F1ANE077JNONNNNN ⁽³⁾		
99	109	149	100	77	116	149	75	20F1ANE099JNONNNNN ⁽³⁾		
125	138	188	125	99	149	188	100	20F1ANE125JNONNNNN ⁽³⁾		
144	158	216	150	125	188	225	125	20F1ANE144JNONNNNN ⁽³⁾		
192	211	288	200	144	216	288	150	20F1ANE192JNONNNNN ⁽³⁾		7
242	266	363	250	192	288	363	200	20F1ANE242JNONNNNN ⁽³⁾		
289	318	434	300	242	363	436	250	20F1ANE289JNONNNNN ⁽³⁾		

(1) Frames 1...5 are IP20, NEMA/UL Type Open. Frames 6...7 are IP00, NEMA/UL Type Open. Frames 1...7 can be converted to IP20, NEMA/UL Type 1 with optional kit (20-750-NEMA1-Fx), where x is the frame size.
 (2) The 5th character determines Input Type; "I" = AC input with precharge and DC terminals, and "A" = AC input with precharge and no DC terminals. For DC input drives, see [DRIVES-56001](#), the PowerFlex Common Bus Configuration Selection Guide.
 (3) The 12th character determines whether an internal dynamic braking IGBT is included; "A" = Internal dynamic braking transistor installed, and "N" = No internal dynamic braking transistor.

575...600V AC, Three-phase Drives (Continued)

Frames 3, 4, and 5 are only 575...600V AC drives. Frames 6 and 7 are dual-voltage drives, and can be operated at 575...600 V or 660...690V AC.

IP54, NEMA/UL Type 12

Normal Duty				Heavy Duty				Cat. No. ⁽¹⁾	Frame Size	
Output Amps			Hp	Output Amps			Hp			
Cont.	60 s	3 s		Cont.	60 s	3 s				
1.7	1.9	2.6	1	1.7	1.4	2.6	1	20FT1GE1P7JAONNNNN	3	
2.7	3	4.1	2	1.7	2.6	4.1	1	20FT1GE2P7JAONNNNN		
3.9	4.29	5.85	3	2.7	4.1	5.9	2	20FT1GE3P9JAONNNNN		
6.1	6.7	9.2	5	3.9	5.9	9.2	3	20FT1GE6P1JAONNNNN		
9	9.9	13.5	7.5	6.1	9.2	13.5	5	20FT1GE9P0JAONNNNN		
11	12.1	16.5	10	9	13.5	16.5	7.5	20FT1GE011JAONNNNN		
17	18.7	25.5	15	11	16.5	25.5	10	20FT1GE017JAONNNNN		
22	24.2	33	20	17	25.5	33	15	20FT1GE022JAONNNNN		
27	29.7	40.5	25	22	33	40.5	20	20FT1GE027JAONNNNN	4	
32	35.2	48	30	27	40.5	48.6	25	20FT1GE032JAONNNNN		
41	45.1	61.5	40	32	48	61.5	30	20FT1GE041JAONNNNN	5	
12	13.2	18	10	9.1	13.7	18	7.5	20F1AGE012JNONNNNN ⁽²⁾	6	
18	19.8	27	15	12	18	27	10	20F1AGE018JNONNNNN ⁽²⁾		
23	25.3	34.5	20	18	27	34.5	15	20F1AGE023JNONNNNN ⁽²⁾		
24	26.4	36	20	22	33	39.6	20	20F1AGE024JNONNNNN ⁽²⁾		
28	30.8	42	25	23	34.5	42	20	20F1AGE028JNONNNNN ⁽²⁾		
33	36.3	49.5	30	28	42	50.4	25	20F1AGE033JNONNNNN ⁽²⁾		
42	46.2	63	40	33	49.5	63	30	20F1AGE042JNONNNNN ⁽²⁾		
53	58	80	50	42	63	80	40	20F1AGE053JNONNNNN ⁽²⁾		
63	69	95	60	52	78	95	50	20F1AGE063JNONNNNN ⁽²⁾		
77	85	116	75	63	95	116	60	20F1AGE077JNONNNNN ⁽²⁾		
99	109	149	100	77	116	149	75	20F1AGE099JNONNNNN ⁽²⁾		
125	138	188	125	99	149	188	100	20F1AGE125JNONNNNN ⁽²⁾		
144	158	216	150	125	188	225	125	20F1AGE144JNONNNNN ⁽²⁾		
192	211	288	200	144	216	288	150	20F1AGE192JNONNNNN ⁽²⁾		7
242	266	363	250	192	288	363	200	20F1AGE242JNONNNNN ⁽²⁾		
289	318	434	300	242	363	436	250	20F1AGE289JNONNNNN ⁽²⁾		

(1) The 5th character determines Input Type; "I" = AC input with precharge and DC terminals, and "A" = AC input with precharge and no DC terminals. For DC input drives, see [DRIVES-SG001](#), the PowerFlex Common Bus Configuration Selection Guide.

(2) The 12th character determines whether an internal dynamic braking IGBT is included; "A" = Internal dynamic braking transistor installed, and "N" = No internal dynamic braking transistor.

600V AC, Three-phase Drives

Frames 3, 4, and 5 are only 600V AC drives. Frames 6 and 7 are dual-voltage drives, and can be operated at 600 V or 690V AC.

IMPORTANT Frames 3, 4, and 5 must not be used in common DC input-sharing applications with Frames 6 or larger drives. For more details, contact your local Rockwell Automation sales office or your Allen-Bradley distributor.

Note: Frame 6...7 IPO0, NEMA Type Open drives can be converted to a flange mount drive (back/heatsink: IP66, NEMA/UL Type 4X) with an optional user installed flange kit (kit 20-750-FLNG4-F6 for Frame 6, and kit 20-750-FLNG4-F7 for Frame 7). See page [14](#) for 600V, Frame 6...7 IPO0, NEMA Type Open drives.

Flange Mount (Front: IP20, NEMA/UL Type Open; Back/Heatsink: IP66, NEMA/UL Type 4X)

Normal Duty				Heavy Duty				Cat. No. (1)	Frame Size
Output Amps			Hp	Output Amps			Hp		
Cont.	60 s	3 s		Cont.	60 s	3 s			
1.7	1.9	2.6	1	1.7	1.4	2.6	1	20F11FE1P7JAONNNNN	3
2.7	3	4.1	2	1.7	2.6	4.1	1	20F11FE2P7JAONNNNN	
3.9	4.29	5.85	3	2.7	4.1	5.9	2	20F11FE3P9JAONNNNN	
6.1	6.7	9.2	5	3.9	5.9	9.2	3	20F11FE6P1JAONNNNN	
9	9.9	13.5	7.5	6.1	9.2	13.5	5	20F11FE9POJAONNNNN	
11	12.1	16.5	10	9	13.5	16.5	7.5	20F11FE011JAONNNNN	
17	18.7	25.5	15	11	16.5	25.5	10	20F11FE017JAONNNNN	
22	24.2	33	20	17	25.5	33	15	20F11FE022JAONNNNN	4
27	29.7	40.5	25	22	33	40.5	20	20F11FE027JAONNNNN	
32	35.2	48	30	27	40.5	48.6	25	20F11FE032JAONNNNN	
41	45.1	61.5	40	32	48	61.5	30	20F11FE041JAONNNNN	5
52	57.2	78.0	50	41	61.5	78	40	20F11FE052JAONNNNN	

(1) The 5th character determines Input Type; "T" = AC input with precharge and DC terminals, and "A" = AC input with precharge and no DC terminals. For DC input drives, see [DRIVES-SG001](#), the PowerFlex Common Bus Configuration Selection Guide.

690V AC, Three-phase Drives

IP00/IP20, NEMA/UL Type Open (1)

Normal Duty				Heavy Duty				Cat. No. (2)	Frame Size
Output Amps			kW	Output Amps			kW		
Cont.	60 s	3 s		Cont.	60 s	3 s			
12	13.2	18	7.5	9	13.5	18	5.5	20F1ANF012JNONNNNN (3)	6
15	16.5	22.5	11	12	18	22.5	7.5	20F1ANF015JNONNNNN (3)	
20	22	30	15	15	22.5	30	11	20F1ANF020JNONNNNN (3)	
23	25.3	34.5	18.5	20	30	36	15	20F1ANF023JNONNNNN (3)	
30	33	45	22	23	34.5	45	18.5	20F1ANF030JNONNNNN (3)	
34	37.4	51	30	30	45	54	22	20F1ANF034JNONNNNN (3)	
46	50.6	69	37	34	51	69	30	20F1ANF046JNONNNNN (3)	
50	55	75	45	46	69	83	37	20F1ANF050JNONNNNN (3)	
61	67	92	55	50	75	92	45	20F1ANF061JNONNNNN (3)	
82	90	123	75	61	92	123	55	20F1ANF082JNONNNNN (3)	
98	108	147	90	82	123	148	75	20F1ANF098JNONNNNN (3)	
119	131	179	110	98	147	179	90	20F1ANF119JNONNNNN (3)	7
142	156	213	132	119	179	214	110	20F1ANF142JNONNNNN (3)	
171	188	257	160	142	213	257	132	20F1ANF171JNONNNNN (3)	
212	233	318	200	171	257	318	160	20F1ANF212JNONNNNN (3)	
263	289	395	250	212	318	395	200	20F1ANF263JNONNNNN (3)	

(1) Frames 6...7 are IP00, NEMA/UL Type Open. Frames 1...7 are IP00, NEMA/UL Type Open. Frames 1...7 can be converted to IP20, NEMA/UL Type 1 with optional kit (20-750-NEMA1-Fx), where x is the frame size.
 (2) The 5th character determines Input Type; "T" = AC input with precharge and DC terminals, and "A" = AC input with precharge and no DC terminals. For DC input drives, see [DRIVES-SG001](#), the PowerFlex Common Bus Configuration Selection Guide.
 (3) The 12th character determines whether an internal dynamic braking IGBT is included; "A" = Internal dynamic braking transistor installed, and "N" = No internal dynamic braking transistor.

690V AC, Three-phase Drives (Continued)**IP54, NEMA/UL Type 12**

Normal Duty				Heavy Duty				Cat. No. ⁽¹⁾	Frame Size
Output Amps			kW	Output Amps			kW		
Cont.	60 s	3 s		Cont.	60 s	3 s			
12	13.2	18	7.5	9	13.5	18	5.5	20F1AGF012JNONNNNN ⁽²⁾	6
15	16.5	22.5	11	12	18	22.5	7.5	20F1AGF015JNONNNNN ⁽²⁾	
20	22	30	15	15	22.5	30	11	20F1AGF020JNONNNNN ⁽²⁾	
23	25.3	34.5	18.5	20	30	36	15	20F1AGF023JNONNNNN ⁽²⁾	
30	33	45	22	23	34.5	45	18.5	20F1AGF030JNONNNNN ⁽²⁾	
34	37.4	51	30	30	45	54	22	20F1AGF034JNONNNNN ⁽²⁾	
46	50.6	69	37	34	51	69	30	20F1AGF046JNONNNNN ⁽²⁾	
50	55	75	45	46	69	83	37	20F1AGF050JNONNNNN ⁽²⁾	
61	67	92	55	50	75	92	45	20F1AGF061JNONNNNN ⁽²⁾	
82	90	123	75	61	92	123	55	20F1AGF082JNONNNNN ⁽²⁾	
98	108	147	90	82	123	148	75	20F1AGF098JNONNNNN ⁽²⁾	
119	131	179	110	98	147	179	90	20F1AGF119JNONNNNN ⁽²⁾	
142	156	213	132	119	179	214	110	20F1AGF142JNONNNNN ⁽²⁾	
171	188	257	160	142	213	257	132	20F1AGF171JNONNNNN ⁽²⁾	7
212	233	318	200	171	257	318	160	20F1AGF212JNONNNNN ⁽²⁾	
263	289	395	250	212	318	395	200	20F1AGF263JNONNNNN ⁽²⁾	

(1) The 5th character determines Input Type; "I" = AC input with precharge and DC terminals, and "A" = AC input with precharge and no DC terminals. For DC input drives, see [DRIVES-56001](#), the PowerFlex Common Bus Configuration Selection Guide.

(2) The 12th character determines whether an internal dynamic braking IGBT is included; "A" = Internal dynamic braking transistor installed, and "N" = No internal dynamic braking transistor.

Flange Mount (Front: IP20, NEMA/UL Type Open; Back/Heatsink: IP66, NEMA/UL Type 4X)

Note: Frame 6...7 IP00, NEMA Type Open drives can be converted to a flange mount drive (Back/Heatsink: IP66, NEMA/UL Type 4X) with an optional user installed flange kit (20-750-FLNG4-F6 for Frame 6, and 20-750-FLNG4-F7 for Frame 7). See page [16](#) for 690V, Frame 6...7 IP00, NEMA Type Open drives.

Product Selection – PowerFlex 753 Common Bus Drives

540V DC Nominal Input - Common Bus Drives

IP00/IP20,NEMA/UL Type Open ⁽¹⁾

Normal Duty				Heavy Duty				Cat.No. ⁽²⁾	Frame Size
Output Amps			kW	Output Amps			kW		
Cont.	60 s	3 s		Cont.	60 s	3 s			
2.1	2.3	3.2	0.75	1.3	2.3	3.2	0.37	20F11RC2P1JA0NNNNN	1
3.5	3.9	5.3	1.5	2.1	3.9	5.3	0.75	20F11RC3P5JA0NNNNN	
5	5.5	7.5	2.2	3.5	5.5	7.5	1.5	20F11RC5P0JA0NNNNN	
8.7	9.6	13.1	4	5	9.6	13.1	2.2	20F11RC8P7JA0NNNNN	
11.5	13.1	17.3	5.5	8.7	13.1	17.3	4	20F11RC0T1JA0NNNNN	
15.4	16.9	23.1	7.5	11.5	17.2	23.1	5.5	20F11RC015JA0NNNNN	
2.1	3.1	3.7	0.75	2.1	3.1	3.7	0.75	20F11NC2P1JA0NNNNN	2
3.5	5.2	6.3	1.5	3.5	5.2	6.3	1.5	20F11NC3P5JA0NNNNN	
5	7.5	9	2.2	5	7.5	9	2.2	20F11NC5P0JA0NNNNN	
8.7	13	15.6	4	8.7	13.0	15.6	4	20F11NC8P7JA0NNNNN	
11.5	17.2	20.7	5.5	11.5	17.2	20.7	5.5	20F11NC0T1JA0NNNNN	
15.4	16.9	23.1	7.5	11.5	17.2	20.7	5.5	20F11NC015JA0NNNNN	
22	24.2	33	11	15.4	24.2	33	7.5	20F11NC022JA0NNNNN	3
30	33	45	15	22	33	45	11	20F11NC030JA0NNNNN	
37	40.7	55.5	18.5	30	45	55.5	15	20F11NC037JA0NNNNN	
43	47.3	64.5	22	37	55.5	66.6	18.5	20F11NC043JA0NNNNN	4
60	66	90	30	44	66	90	22	20F11NC060JA0NNNNN	
72	79.2	108	37	60	90	108	30	20F11NC072JA0NNNNN	5
85	93.5	128	45	72	108	130	37	20F14NC085JA0NNNNN	
104	114	156	55	85	128	156	45	20F14NC104JA0NNNNN	6
140	154	210	75	104	156	210	55	20F14NC140JNONNNNN ⁽³⁾	
170	187	255	90	140	210	255	75	20F14NC170JNONNNNN ⁽³⁾	
205	226	308	110	170	255	308	90	20F14NC205JNONNNNN ⁽³⁾	
260	286	390	132	205	308	390	110	20F14NC260JNONNNNN ⁽³⁾	7
302	332	453	160	260	390	468	132	20F14NC302JNONNNNN ⁽³⁾	
367	404	551	200	302	453	551	160	20F14NC367JNONNNNN ⁽³⁾	
456	502	684	250	367	551	684	200	20F14NC456JNONNNNN ⁽³⁾	
477	525	716	270	367	551	684	200	20F14NC477JNONNNNN ⁽³⁾	

(1) Frames 1...5 are IP20,NEMA/UL Type Open. Frames 6...7 are IP00,NEMA/UL Type Open. Frames 1...7 can be converted to IP20, NEMA/UL Type1 with optional kit (20-750-NEMA1-Fx), where x is the frame size of the drive.
 (2) The 11th character determines default Filtering and Common Mode Cap jumper configuration; 'J'= Installed, and 'A'= Removed.
 (3) The 12th character determines whether an internal dynamic braking IGBT is included; 'A'= Internal dynamic braking transistor installed, and 'N'= No internal dynamic braking transistor.

540 VDC Nominal Input - Common Bus Drives (continued)

IP54, NEMA/UL Type 12

Normal Duty				Heavy Duty				Cat.No. ⁽¹⁾	Frame Size
Output Amps			kW	Output Amps			kW		
Cont.	60 s	3 s		Cont.	60 s	3 s			
2.1	3.1	3.7	0.75	2.1	3.1	3.7	0.75	20F11GC2P1JA0NNNNN	2
3.5	5.2	6.3	1.5	3.5	5.2	6.3	1.5	20F11GC3P5JA0NNNNN	
5	7.5	9	2.2	5	7.5	9	2.2	20F11GC5P0JA0NNNNN	
8.7	13	15.6	4	8.7	13	15.6	4	20F11GC8P7JA0NNNNN	
11.5	17.2	20.7	5.5	11.5	17.2	20.7	5.5	20F11GC0T1JA0NNNNN	
15.4	16.9	23.1	7.5	11.5	17.2	20.7	5.5	20F11GC015JA0NNNNN	
22	24.2	33	11	15.4	24.2	33	7.5	20F11GC022JA0NNNNN	
30	33	45	15	22	33	45	11	20F11GC030JA0NNNNN	3
37	40.7	55.5	18.5	30	45	55.5	15	20F11GC037JA0NNNNN	
43	47.3	64.5	22	37	55.5	66.6	18.5	20F11GC043JA0NNNNN	
60	66	90	30	44	66	90	22	20F11GC060JA0NNNNN	4
72	79.2	108	37	60	90	108	30	20F14GC072JA0NNNNN	5
85	93.5	128	45	72	108	130	37	20F14GC085JA0NNNNN	
104	114	156	55	85	128	156	45	20F14GC104JN0NNNNN ⁽²⁾	6
140	154	210	75	104	156	210	55	20F14GC140JN0NNNNN ⁽²⁾	
170	187	255	90	140	210	255	75	20F14GC170JN0NNNNN ⁽²⁾	
205	226	308	110	170	255	308	90	20F14GC205JN0NNNNN ⁽²⁾	
260	286	390	132	205	308	390	110	20F14GC260JN0NNNNN ⁽²⁾	7
302	332	453	160	260	390	468	132	20F14GC302JN0NNNNN ⁽²⁾	
367	404	551	200	302	453	551	160	20F14GC367JN0NNNNN ⁽²⁾	
456	502	684	250	367	551	684	200	20F14GC456JN0NNNNN ⁽²⁾	

(1) The 11th character determines default Filtering and Common Mode Cap jumper configuration; 'J'= Installed, and 'A'= Removed.

(2) The 12th character determines whether an internal dynamic braking IGBT is included; 'A'= Internal dynamic braking transistor installed, and 'N'= No internal dynamic braking transistor.

540 VDC Nominal Input - Common Bus Drives (continued)

IMPORTANT Frame 6...7 IP00, NEMA Type Open drives can be converted to a flange mount drive (back/heatsink: IP66,NEMA/UL Type 4X) with an optional user installed flange kit (kit20-750-FLNG4-F6 for Frame 6, and kit 20-750-FLNG4-F7 for Frame 7). See page 18 for 540V DC, Frame 6...7 IP00, NEMA Type Open drives.

Flange Mount (Front: IP20,NEMA/UL Type Open; Back/Heatsink: IP66,NEMA/UL Type 4X)

Normal Duty				Heavy Duty				Cat.No. ⁽¹⁾	Frame Size
Output Amps			kW	Output Amps			kW		
Cont.	60 s	3 s		Cont.	60 s	3 s			
2.1	3.1	3.7	0.75	2.1	3.1	3.7	0.75	20F11FC2P1JA0NNNNN	2
3.5	5.2	6.3	1.5	3.5	5.2	6.3	1.5	20F11FC3P5JA0NNNNN	
5	7.5	9	2.2	5	7.5	9	2.2	20F11FC5P0JA0NNNNN	
8.7	13	15.6	4	8.7	13	15.6	4	20F11FC8P7JA0NNNNN	
11.5	17.2	20.7	5.5	11.5	17.2	20.7	5.5	20F11FC0T1JA0NNNNN	
15.4	16.9	23.1	7.5	11.5	17.2	20.7	5.5	20F11FC014JA0NNNNN	
22	24.2	33	11	15.4	24.2	33	7.5	20F11FC022JA0NNNNN	
30	33	45	15	22	33	45	11	20F11FC030JA0NNNNN	3
37	40.7	55.5	18.5	30	45	55.5	15	20F11FC037JA0NNNNN	
43	47.3	64.5	22	37	55.5	66.6	18.5	20F11FC043JA0NNNNN	

Flange Mount (Front: IP20,NEMA/UL Type Open; Back/Heatsink: IP66,NEMA/UL Type 4X)

Normal Duty				Heavy Duty				Cat.No. ⁽¹⁾	Frame Size
Output Amps			kW	Output Amps			kW		
Cont.	60 s	3 s		Cont.	60 s	3 s			
60	66	90	30	44	66	90	22	20F11FC060JA0NNNNN	4
72	79.2	108	37	60	90	108	30	20F11FC072JA0NNNNN	
85	93.5	128	45	72	108	130	37	20F14FC085JA0NNNNN	5
104	114	156	55	85	128	156	45	20F14FC104JA0NNNNN	

(1) The 11th character determines default filtering and common mode cap jumper configuration; 'J'= Installed, and 'A'= Removed.

650V DC Nominal Input - Common Bus Drives

IP00/IP20,NEMA/UL Type Open ⁽¹⁾

Normal Duty				Heavy Duty				Cat.No. ⁽²⁾	Frame Size
Output Amps			Hp	Output Amps			Hp		
Cont.	60 s	3 s		Cont.	60 s	3 s			
2.1	2.3	3.2	1	1.1	2.3	3.2	0.5	20F11RD2P1JA0NNNNN	1
3.4	3.7	5.1	2	2.8	4.2	5.1	1	20F11RD3P4JA0NNNNN	
5	5.5	7.5	3	3.4	5.5	7.5	2	20F11RD5P0JA0NNNNN	
8	8.8	12	5	5	8.8	12	3	20F11RD8P0JA0NNNNN	
11	12.1	16.5	7.5	8	12.1	16.5	5	20F11RD011JA0NNNNN	
14	15.4	21	10	11	16.5	21	7.5	20F11RD014JA0NNNNN	
2.1	3.1	3.7	1	2.1	3.1	3.7	1	20F11ND2P1JA0NNNNN	2
3.4	5.1	6.1	2	3.4	5.1	6.1	2	20F11ND3P4JA0NNNNN	
5	7.5	9	3	5	7.5	9	3	20F11ND5P0JA0NNNNN	
8	12	14.4	5	8	12	14.4	5	20F11ND8P0JA0NNNNN	
11	16.5	19.8	7.5	11	16.5	19.8	7.5	20F11ND011JA0NNNNN	
14	15.4	21	10	11	16.5	21	7.5	20F11ND014JA0NNNNN	
22	24.2	33	15	14	24.2	33	15	20F11ND022JA0NNNNN	3
27	29.7	40.5	20	22	33	40.5	15	20F11ND027JA0NNNNN	
34	37.4	51	25	27	40.5	51	20	20F11ND034JA0NNNNN	
40	44	60	30	34	51	61.2	25	20F11ND040JA0NNNNN	
52	57.2	78	40	40	60	78	30	20F11ND052JA0NNNNN	
65	71.5	97.5	50	52	78	97.5	40	20F11ND065JA0NNNNN	
77	84.7	116	60	65	97.5	116	50	20F14ND077JA0NNNNN	5
96	106	144	75	77	116	144	60	20F14ND096JA0NNNNN	
125	138	188	100	96	144	188	75	20F14ND125JN0NNNNN ⁽³⁾	6
156	172	234	125	125	188	234	100	20F14ND156JN0NNNNN ⁽³⁾	
186	205	279	150	156	234	281	125	20F14ND186JN0NNNNN ⁽³⁾	
248	273	372	200	186	279	372	150	20F14ND248JN0NNNNN ⁽³⁾	
302	332	453	250	248	372	453	200	20F14ND302JN0NNNNN ⁽³⁾	7
361	397	542	300	302	453	535	250	20F14ND361JN0NNNNN ⁽³⁾	
415	457	623	350	361	542	650	300	20F14ND415JN0NNNNN ⁽³⁾	
477	525	716	400	361	542	650	300	20F14ND477JN0NNNNN ⁽³⁾	

(1) Frames 1...5 are IP20, NEMA/UL Type Open. Frames 6...7 are IP00, NEMA/UL Type Open. Frames 1...7 can be converted to IP20, NEMA/UL Type1 with optional kit (20-750-NEMA1-Fx), where x is the frame size of the drive.

(2) The 11th character determines default Filtering and Common Mode Cap jumper configuration; 'J'= Installed, and 'A'= Removed.

(3) The 12th character determines whether an internal dynamic braking IGBT is included; 'A'= Internal dynamic braking transistor installed, and 'N'= No internal dynamic braking transistor.

650V DC Nominal Input - Common Bus Drives (continued)

IP54, NEMA/UL Type12

Normal Duty				Heavy Duty				Cat.No. ⁽¹⁾	Frame Size
Output Amps			Hp	Output Amps			Hp		
Cont.	60 s	3 s		Cont.	60 s	3 s			
2.1	3.1	3.7	1	2.1	3.1	3.7	1	20F11GD2P1JA0NNNNN	2
3.4	5.1	6.1	2	3.4	5.1	6.1	2	20F11GD3P4JA0NNNNN	
5	7.5	9	3	5	7.5	9	3	20F11GD5P0JA0NNNNN	
8	12	14.4	5	8	12	14.4	5	20F11GD8P0JA0NNNNN	
11	16.5	19.8	7.5	11	16.5	19.8	7.5	20F11GD011JA0NNNNN	
14	15.4	21	10	11	16.5	21	7.5	20F11GD014JA0NNNNN	
22	24.2	33	15	14	24.2	33	15	20F11GD022JA0NNNNN	
27	29.7	40.5	20	22	33	40.5	15	20F11GD027JA0NNNNN	3
34	37.4	51	25	27	40.5	51	20	20F11GD034JA0NNNNN	
40	44	60	30	34	51	61.2	25	20F11GD040JA0NNNNN	
52	57.2	78	40	40	60	78	30	20F11GD052JA0NNNNN	4
65	71.5	97.5	50	52	78	97.5	40	20F14GD065JA0NNNNN	5
77	84.7	116	60	65	97.5	116	50	20F14GD077JA0NNNNN	
96	106	144	75	77	116	144	60	20F14GD096JN0NNNNN ⁽²⁾	6
125	138	188	100	96	144	188	75	20F14GD125JN0NNNNN ⁽²⁾	
156	172	234	125	125	188	234	100	20F14GD156JN0NNNNN ⁽²⁾	
186	205	279	150	156	234	281	125	20F14GD186JN0NNNNN ⁽²⁾	
248	273	372	200	186	279	372	150	20F14GD248JN0NNNNN ⁽²⁾	7
302	332	453	250	248	372	453	200	20F14GD302JN0NNNNN ⁽²⁾	
361	397	542	300	302	453	535	250	20F14GD361JN0NNNNN ⁽²⁾	
415	457	623	350	361	542	650	300	20F14GD415JN0NNNNN ⁽²⁾	

(1) The 11th character determines default Filtering and Common Mode Cap jumper configuration; 'J'= Installed, and 'A'= Removed.

(2) The 12th character determines whether an internal dynamic braking IGBT is included; 'A'= Internal dynamic braking transistor installed, and 'N'= No internal dynamic braking transistor.

650V DC Nominal Input - Common Bus Drives (continued)

IMPORTANT Frame 6...7 IP00, NEMA Type Open drives can be converted to a flange mount drive (back/heatsink: IP66, NEMA/UL Type 4X) with an optional user installed flange kit (kit 20-750-FLNG4-F6 for Frame 6, and kit 20-750-FLNG4-F7 for Frame 7). See page 20 for 650V DC, Frame 6...7 IP00, NEMA Type Open drives.

Flange Mount (Front: IP20, NEMA/UL Type Open; Back/Heatsink: IP66, NEMA/UL Type 4X)

Normal Duty				Heavy Duty				Cat.No. ⁽¹⁾	Frame Size
Output Amps			Hp	Output Amps			Hp		
Cont.	60 s	3 s		Cont.	60 s	3 s			
2.1	3.1	3.7	1	2.1	3.1	3.7	1	20F11FD2P1JA0NNNNN	2
3.4	5.1	6.1	2	3.4	5.1	6.1	2	20F11FD3P4JA0NNNNN	
5	7.5	9	3	5	7.5	9.0	3	20F11FD5P0JA0NNNNN	
8	12	14.4	5	8	12	14.4	5	20F11FD8P0JA0NNNNN	
11	16.5	19.8	7.5	11	16.5	19.8	7.5	20F11FD011JA0NNNNN	
14	15.4	21	10	11	16.5	21	7.5	20F11FD014JA0NNNNN	
22	24.2	33	15	14	24.2	33	15	20F11FD022JA0NNNNN	
27	29.7	40.5	20	22	33	40.5	15	20F11FD027JA0NNNNN	3
34	37.4	51	25	27	40.5	51	20	20F11FD034JA0NNNNN	
40	44	60	30	34	51	61.2	25	20F11FD040JA0NNNNN	

Flange Mount (Front: IP20, NEMA/UL Type Open; Back/Heatsink: IP66, NEMA/UL Type 4X) (Continued)

Normal Duty				Heavy Duty				Cat.No. (1)	Frame Size
Output Amps			Hp	Output Amps			Hp		
Cont.	60 s	3 s		Cont.	60 s	3 s			
52	57.2	78	40	40	60	78	30	20F11FD052JA0NNNNN	4
65	71.5	97.5	50	52	78	97.5	40	20F11FD065JA0NNNNN	
77	84.7	116	60	65	97.5	116	50	20F14FD077JA0NNNNN	5
96	106	144	75	77	116	144	60	20F14FD096JA0NNNNN	

(1) The 11th character determines default Filtering and Common Mode Cap jumper configuration; 'J'= Installed, and 'A'= Removed.

810V DC Nominal Input - Common Bus Drives

IMPORTANT At 810V DC, PowerFlex 750-series Frames 3...5 drives cannot be used on the same common DC bus as 810/932V DC PowerFlex 750-series Frames 6...10 drives. For more details, contact your local Rockwell Automation sales office or your Allen-Bradley distributor.

IP00/IP20,NEMA/UL Type Open (1)

Normal Duty				Heavy Duty				Cat.No. (2)	Frame Size
Output Amps			Hp	Output Amps			Hp		
Cont.	60 s	3 s		Cont.	60 s	3 s			
1.7	1.9	2.6	1	1.7	1.4	2.6	1	20F11NE1P7JA0NNNNN	3
2.7	3	4.1	2	1.7	2.6	4.1	1	20F11NE2P7JA0NNNNN	
3.9	4.29	5.85	3	2.7	4.1	5.9	2	20F11NE3P9JA0NNNNN	
6.1	6.7	9.2	5	3.9	5.9	9.2	3	20F11NE6P1JA0NNNNN	
9	9.9	13.5	7.5	6.1	9.2	13.5	5	20F11NE9P0JA0NNNNN	
11	12.1	16.5	10	9	13.5	16.5	7.5	20F11NE0T1JA0NNNNN	
17	18.7	25.5	15	11	16.5	25.5	10	20F11NE017JA0NNNNN	
22	24.2	33	20	17	25.5	33	15	20F11NE022JA0NNNNN	
27	29.7	40.5	25	22	33	40.5	20	20F11NE027JA0NNNNN	4
32	35.2	48	30	27	40.5	48.6	25	20F11NE032JA0NNNNN	
41	45.1	61.5	40	32	48	61.5	30	20F14NE041JA0NNNNN	5
52	57.2	78	50	41	61.5	78	40	20F14NE052JA0NNNNN	
12	13.2	18	10	9.1	13.7	18	7.5	20F14NE012JNONNNNN (3)	6
18	19.8	27	15	12	18	27	10	20F14NE018JNONNNNN (3)	
23	25.3	34.5	20	18	27	34.5	15	20F14NE023JNONNNNN (3)	
24	26.4	36	20	22	33	39.6	20	20F14NE024JNONNNNN (3)	
28	30.8	42	25	23	34.5	42	20	20F14NE028JNONNNNN (3)	
33	36.3	49.5	30	28	42	50.4	25	20F14NE033JNONNNNN (3)	
42	46.2	63	40	33	49.5	63	30	20F14NE042JNONNNNN (3)	
53	58	80	50	42	63	80	40	20F14NE053JNONNNNN (3)	
63	69	95	60	52	78	95	50	20F14NE063JNONNNNN (3)	
77	85	116	75	63	95	116	50	20F14NE077JNONNNNN (3)	
99	109	149	100	77	116	149	60	20F14NE099JNONNNNN (3)	7
125	138	188	125	99	149	188	75	20F14NE125JNONNNNN (3)	
144	158	216	150	125	188	225	100	20F14NE144JNONNNNN (3)	
192	211	288	200	144	216	288	125	20F14NE192JNONNNNN (3)	
242	266	363	250	192	288	363	150	20F14NE242JNONNNNN (3)	
289	318	434	300	242	363	436	200	20F14NE289JNONNNNN (3)	

(1) Frames 3...5 are IP20, NEMA/UL Type Open. Frames 6...7 are IP00, NEMA/UL Type Open. Frames 3...7 can be converted to IP20, NEMA/UL Type 1 with optional kit (20-750-NEMA1-Fx), where x is the frame size of the drive.

(2) The 11th character determines default Filtering and Common Mode Cap jumper configuration; 'J'= Installed, and 'A'= Removed.

(3) The 12th character determines whether an internal dynamic braking IGBT is included; 'A'= Internal dynamic braking transistor installed, and 'N'= No internal dynamic braking transistor.

810V DC Nominal Input - Common Bus Drives (continued)

IMPORTANT At 810V DC, PowerFlex 750-series Frames 3...5 drives cannot be used on the same common DC bus as 810/932V DC PowerFlex 750-series Frames 6...10 drives. For more details, contact your local Rockwell Automation sales office or your Allen-Bradley distributor.

IP54,NEMA/ULType12

Normal Duty				Heavy Duty				Cat.No. ⁽¹⁾	Frame Size
Output Amps			Hp	Output Amps			Hp		
Cont.	60 s	3 s		Cont.	60 s	3 s			
1.7	1.9	2.6	1	1.7	1.4	2.6	1	20F11GE1P7JA0NNNNN	3
2.7	3	4.1	2	1.7	2.6	4.1	1	20F11GE2P7JA0NNNNN	
3.9	4.29	5.85	3	2.7	4.1	5.9	2	20F11GE3P9JA0NNNNN	
6.1	6.7	9.2	5	3.9	5.9	9.2	3	20F11GE6P1JA0NNNNN	
9	9.9	13.5	7.5	6.1	9.2	13.5	5	20F11GE9P0JA0NNNNN	
11	12.1	16.5	10	9	13.5	16.5	7.5	20F11GE011JA0NNNNN	
17	18.7	25.5	15	11	16.5	25.5	10	20F11GE017JA0NNNNN	
22	24.2	33	20	17	25.5	33	15	20F11GE022JA0NNNNN	
27	29.7	40.5	25	22	33	40.5	20	20F11GE027JA0NNNNN	4
32	35.2	48	30	27	40.5	48.6	25	20F11GE032JA0NNNNN	
41	45.1	61.5	40	32	48	61.5	30	20F14GE041JA0NNNNN	5
12	13.2	18	10	9.1	13.7	18	7.5	20F14GE012JNONNNNN ⁽²⁾	6
18	19.8	27	15	12	18	27	10	20F14GE018JNONNNNN ⁽²⁾	
23	25.3	34.5	20	18	27	34.5	15	20F14GE023JNONNNNN ⁽²⁾	
24	26.4	36	20	22	33	39.6	20	20F14GE024JNONNNNN ⁽²⁾	
28	30.8	42	25	23	34.5	42	20	20F14GE028JNONNNNN ⁽²⁾	
33	36.3	49.5	30	28	42	50.4	25	20F14GE033JNONNNNN ⁽²⁾	
42	46.2	63	40	33	49.5	63	30	20F14GE042JNONNNNN ⁽²⁾	
53	58	80	50	42	63	80	40	20F14GE053JNONNNNN ⁽²⁾	
63	69	95	60	52	78	95	50	20F14GE063JNONNNNN ⁽²⁾	
77	85	116	75	63	95	116	50	20F14GE077JNONNNNN ⁽²⁾	
99	109	149	100	77	116	149	60	20F14GE099JNONNNNN ⁽²⁾	
125	138	188	125	99	149	188	75	20F14GE125JNONNNNN ⁽²⁾	
144	158	216	150	125	188	225	100	20F14GE144JNONNNNN ⁽²⁾	
192	211	288	200	144	216	288	125	20F14GE192JNONNNNN ⁽²⁾	7
242	266	363	250	192	288	363	150	20F14GE242JNONNNNN ⁽²⁾	
289	318	434	300	242	363	436	200	20F14GE289JNONNNNN ⁽²⁾	

(1) The 11th character determines default Filtering and Common Mode Cap jumper configuration; 'J'= Installed, and 'A'= Removed.

(2) The 12th character determines whether an internal dynamic braking IGBT is included; 'A'= Internal dynamic braking transistor installed, and 'N'= No internal dynamic braking transistor.

810V DC Nominal Input - Common Bus Drives (continued)

IMPORTANT At 810V DC, PowerFlex 750-series Frames 3...5 drives cannot be used on the same common DC bus as 810/932V DC PowerFlex750-series Frames 6...10 drives. For more details, contact your local Rockwell Automation sales office or your Allen-Bradley distributor.

IMPORTANT Frame 6...7 IP00, NEMA Type Open drives can be converted to a flange mount drive (back/heatsink: IP66,NEMA/UL Type 4X) with an optional user installed flange kit (kit 20-750-FLNG4-F6 for Frame 6, and kit 20-750-FLNG4-F7 for Frame 7). See page 22 for 810V DC, Frame 6...7 IP00, NEMA Type Open drives.

Flange Mount (Front: IP20,NEMA/UL Type Open; Back/Heatsink: IP66,NEMA/UL Type 4X)

Normal Duty				Heavy Duty				Cat.No. ⁽¹⁾	Frame Size
Output Amps			Hp	Output Amps			Hp		
Cont.	60 s	3 s		Cont.	60 s	3 s			
1.7	1.9	2.6	1	1.7	1.4	2.6	1	20F11FE1P7JA0NNNNN	3
2.7	3	4.1	2	1.7	2.6	4.1	1	20F11FE2P7JA0NNNNN	
3.9	4.29	5.85	3	2.7	4.1	5.9	2	20F11FE3P9JA0NNNNN	
6.1	6.7	9.2	5	3.9	5.9	9.2	3	20F11FE6P1JA0NNNNN	
9	9.9	13.5	7.5	6.1	9.2	13.5	5	20F11FE9P0JA0NNNNN	
11	12.1	16.5	10	9	13.5	16.5	7.5	20F11FE011JA0NNNNN	
17	18.7	25.5	15	11	16.5	25.5	10	20F11FE017JA0NNNNN	
22	24.2	33	20	17	25.5	33	15	20F11FE022JA0NNNNN	
27	29.7	40.5	25	22	33	40.5	20	20F11FE027JA0NNNNN	4
32	35.2	48	30	27	40.5	48.6	25	20F11FE032JA0NNNNN	
41	45.1	61.5	40	32	48	61.5	30	20F14FE041JA0NNNNN	5
52	57.2	78.0	50	41	61.5	78	40	20F14FE052JA0NNNNN	

(1) The 11th character determines default Filtering and Common Mode Cap jumper configuration; 'J'= Installed, and 'A'= Removed.

932V DC Nominal Input - Common Bus Drives

IP00/IP20,NEMA/UL Type Open ⁽¹⁾

Normal Duty				Heavy Duty				Cat.No. ^{(2) (3)}	Frame Size
Output Amps			kW	Output Amps			kW		
Cont.	60 s	3 s		Cont.	60 s	3 s			
12	13.2	18	7.5	9	13.5	18	5.5	20F14NF012JN0NNNNN	6
15	16.5	22.5	11	12	18	22.5	7.5	20F14NF015JN0NNNNN	
20	22	30	15	15	22.5	30	11	20F14NF020JN0NNNNN	
23	25.3	34.5	18.5	20	30	36	15	20F14NF023JN0NNNNN	
30	33	45	22	23	34.5	45	18.5	20F14NF030JN0NNNNN	
34	37.4	51	30	30	45	54	22	20F14NF034JN0NNNNN	
46	50.6	69	37	34	51	69	30	20F14NF046JN0NNNNN	
50	55	75	45	46	69	83	37	20F14NF050JN0NNNNN	
61	67	92	55	50	75	92	45	20F14NF061JN0NNNNN	
82	90	123	75	61	92	123	55	20F14NF082JN0NNNNN	
98	108	147	90	82	123	148	75	20F14NF098JN0NNNNN	
119	131	179	110	98	147	179	90	20F14NF119JN0NNNNN	
142	156	213	132	119	179	214	110	20F14NF142JN0NNNNN	
171	188	257	160	142	213	257	132	20F14NF171JN0NNNNN	
212	233	318	200	171	257	318	160	20F14NF212JN0NNNNN	
263	289	395	250	212	318	395	200	20F14NF263JN0NNNNN	

(1) Frames 6...7 are IP00, NEMA/UL Type Open. Frames 1...7 can be converted to IP20, NEMA/UL Type 1 with optional kit (20-750-NEMA1-Fx), where x is the frame size of the drive.

(2) The 11th character determines default Filtering and Common Mode Cap jumper configuration; 'J'= Installed, and 'A'= Removed.

(3) The 12th character determines whether an internal dynamic braking IGBT is included; 'A'= Internal dynamic braking transistor installed, and 'N'= No internal dynamic braking transistor.

932V DC Nominal Input - Common Bus Drives (continued)

IP54, NEMA/UL Type 12

Normal Duty				Heavy Duty				Cat.No. (1)(2)	Frame Size
Outputs Amp			kW	Output Amps			kW		
Cont.	60 s	3 s		Cont.	60 s	3 s			
12	13.2	18	7.5	9	13.5	18	5.5	20F14GF012JNONNNNN	6
15	16.5	22.5	11	12	18	22.5	7.5	20F14GF015JNONNNNN	
20	22	30	15	15	22.5	30	11	20F14GF020JNONNNNN	
23	25.3	34.5	18.5	20	30	36	15	20F14GF023JNONNNNN	
30	33	45	22	23	34.5	45	18.5	20F14GF030JNONNNNN	
34	37.4	51	30	30	45	54	22	20F14GF034JNONNNNN	
46	50.6	69	37	34	51	69	30	20F14GF046JNONNNNN	
50	55	75	45	46	69	83	37	20F14GF050JNONNNNN	
61	67	92	55	50	75	92	45	20F14GF061JNONNNNN	
82	90	123	75	61	92	123	55	20F14GF082JNONNNNN	
98	108	147	90	82	123	148	75	20F14GF098JNONNNNN	
119	131	179	110	98	147	179	90	20F14GF119JNONNNNN	
142	156	213	132	119	179	214	110	20F14GF142JNONNNNN	
171	188	257	160	142	213	257	132	20F14GF171JNONNNNN	
212	233	318	200	171	257	318	160	20F14GF212JNONNNNN	
263	289	395	250	212	318	395	200	20F14GF263JNONNNNN	

(1) The 11th character determines default Filtering and Common Mode Cap jumper configuration; 'J'= Installed, and 'A'= Removed.

(2) The 12th character determines whether an internal dynamic braking IGBT is included; 'A'= Internal dynamic braking transistor installed, and 'N'= No internal dynamic braking transistor.

Flange Mount (Front: IP20,NEMA/UL Type Open; Back/Heatsink: IP66,NEMA/UL Type4X)

IMPORTANT Frame 6...7 IP00, NEMA Type Open drives can be converted to a flange mount drive (Back/Heatsink: IP66,NEMA/UL Type4X) with an optional user installed flange kit (20-750-FLNG4-F6 for Frame 6, and 20-750-FLNG4-F7 for Frame 7). See page 24 for 932V DC, Frame 6...7 IP00, NEMA Type Open drives.

Product Selection – PowerFlex 755

200...240V AC, Three-phase Drives

IP00/IP20, NEMA/UL Type Open (1)

Normal Duty					Heavy Duty					Cat. No. (2)	Frame Size
Output Amps: 240V (208V) (3)			HP	kW	Output Amps: 240V (208V) (3)			HP	kW		
Cont.	60 s	3 s			Cont.	60 s	3 s				
2.2 (2.5)	2.4 (2.7)	3.3 (3.7)	0.5	0.37	2.2 (2.5)	3.3 (3.7)	3.9 (4.5)	0.5	0.37	20G11RB2P2JA0NNNNN	1
4.2 (4.8)	4.6 (5.2)	6.3 (7.2)	1	0.75	2.2 (2.5)	4.6 (5.2)	6.3 (7.2)	0.5	0.37	20G11RB4P2JA0NNNNN	
6.8 (7.8)	7.4 (8.5)	10.2 (11.7)	2	1.5	4.2 (4.8)	7.4 (8.5)	10.2 (11.7)	1	0.75	20G11RB6P8JA0NNNNN	
9.6 (11)	10.5 (12.1)	14.4 (16.5)	3	2.2	6.8 (7.8)	10.5 (12.1)	14.4 (16.5)	2	1.5	20G11RB9P6JA0NNNNN	
15.3 (15.3)	16.8 (16.8)	22.9 (22.9)	5	4	9.6 (11)	16.8 (16.8)	22.9 (22.9)	3	2.2	20G11RB015JA0NNNNN	
2.2 (2.5)	3.3 (3.7)	3.9 (4.5)	0.5	0.37	2.2 (2.5)	3.3 (3.7)	3.9 (4.5)	0.5	0.37	20G11NB2P2JA0NNNNN	2
4.2 (4.8)	6.3 (7.2)	7.5 (8.6)	1	0.75	4.2 (4.8)	6.3 (7.2)	7.5 (8.6)	1	0.75	20G11NB4P2JA0NNNNN	
6.8 (7.8)	10.2 (11.7)	12.2 (14)	2	1.5	6.8 (7.8)	10.2 (11.7)	12.2 (14)	2	1.5	20G11NB6P8JA0NNNNN	
9.6 (11)	14.4 (16.5)	17.2 (19.8)	3	2.2	9.6 (11)	14.4 (16.5)	17.2 (19.8)	3	2.2	20G11NB9P6JA0NNNNN	
15.3 (17.5)	16.8 (19.2)	22.9 (26.2)	5	4	9.6 (11)	16.8 (19.2)	22.9 (26.2)	3	2.2	20G11NB015JA0NNNNN	
22 (22)	24.2 (24.2)	33 (33)	7.5	5.5	15.3 (17.5)	24.2 (24.2)	33 (33)	5	4	20G11NB022JA0NNNNN	3
28 (32.2)	30.8 (35.4)	42 (48.3)	10	7.5	22 (22)	33 (35.4)	42 (48.3)	7.5	5.5	20G11NB028JA0NNNNN	
42 (43)	46.2 (47.3)	63 (64.5)	15	11	28 (32.2)	46.2 (48.3)	63 (64.5)	10	7.5	20G11NB042JA0NNNNN	
54 (60)	59.4 (66)	81 (90)	20	15	42 (43)	63 (64.5)	81 (90)	15	11	20G11NB054JA0NNNNN	

IP00/IP20, NEMA/UL Type Open (Continued) ⁽¹⁾

Normal Duty					Heavy Duty					Cat. No. ⁽²⁾	Frame Size
Output Amps: 240V (208V) ⁽³⁾			HP	kW	Output Amps: 240V (208V) ⁽³⁾			HP	kW		
Cont.	60 s	3 s			Cont.	60 s	3 s				
70 (78.2)	77 (86)	105 (117)	25	18.5	54 (60)	81 (90)	105 (117)	20	15	20G11NB070JA0NNNNN	5
80 (92)	88 (101)	120 (138)	30	22	70 (78.2)	105 (117)	126 (140)	25	18.5	20G11NB080JA0NNNNN	
104 (120)	114 (132)	156 (180)	40	30	80 (92)	120 (138)	156 (180)	30	22	20G1ANB104JNONNNNN ⁽⁴⁾	6
130 (150)	143 (165)	195 (225)	50	37	104 (120)	156 (180)	195 (225)	40	30	20G1ANB130JNONNNNN ⁽⁴⁾	
154 (177)	169 (194)	231 (265)	60	45	130 (150)	195 (225)	234 (270)	50	37	20G1ANB154JNONNNNN ⁽⁴⁾	
192 (221)	211 (243)	288 (331)	75	55	154 (177)	231 (265)	288 (331)	60	45	20G1ANB192JNONNNNN ⁽⁴⁾	
260 (260)	286 (286)	390 (390)	100	66	192 (221)	288 (331)	390 (390)	75	55	20G1ANB260JNONNNNN ⁽⁴⁾	7
312 (359)	343 (394)	468 (538)	125	90	260 (260)	390 (394)	468 (538)	100	66	20G1ANB312JNONNNNN ⁽⁴⁾	
360 (414)	396 (455)	540 (621)	150	110	312 (359)	468 (538)	561 (646)	125	90	20G1ANB360JNONNNNN ⁽⁴⁾	
477 (477)	524 (524)	715 (715)	200	132	312 (359)	468 (538)	561 (646)	125	90	20G1ANB477JNONNNNN ⁽⁴⁾	

- (1) Frames 1...5 are IP20, NEMA/UL Type Open. Frames 6...7 are IP00, NEMA/UL Type Open. Frames 1...7 can be converted to IP20, NEMA/UL Type 1 with optional kit (20-750-NEMA1-Fx), where x is the frame size.
- (2) The 5th character determines Input Type; "T" = AC input with precharge and DC terminals, and "A" = AC input with precharge and no DC terminals. For DC input drives, see [DRIVES-5G001](#), the PowerFlex Common Bus Configuration Selection Guide.
- (3) Drive must be programmed to lower voltage to obtain the currents shown in parentheses.
- (4) The 12th character determines whether an internal dynamic braking IGBT is included; "A" = Internal dynamic braking transistor installed, and "N" = No internal dynamic braking transistor.

200...240V AC, Three-phase Drives (Continued)

IP54, NEMA/UL Type 12

Normal Duty					Heavy Duty					Cat. No. ⁽¹⁾	Frame Size
Output Amps: 240V (208V) ⁽²⁾			HP	kW	Output Amps: 240V (208V) ⁽²⁾			HP	kW		
Cont.	60 s	3 s			Cont.	60 s	3 s				
2.2 (2.5)	3.3 (3.8)	4 (4.5)	0.5	0.37	2.2 (2.5)	3.3 (3.7)	3.9 (4.5)	0.5	0.37	20G11GB2P2JA0NNNNN	2
4.2 (4.8)	6.3 (7.2)	7.5 (8.6)	1	0.75	4.2 (4.8)	6.3 (7.2)	7.5 (8.6)	1	0.75	20G11GB4P2JA0NNNNN	
6.8 (7.8)	10.2 (11.7)	12.2 (14)	2	1.5	6.8 (7.8)	10.2 (11.7)	12.2 (14)	2	1.5	20G11GB6P8JA0NNNNN	
9.6 (11)	14.4 (16.5)	17.2 (19.8)	3	2.2	9.6 (11)	14.4 (16.5)	17.2 (19.8)	3	2.2	20G11GB9P6JA0NNNNN	
15.3 (17.5)	16.8 (19.2)	22.9 (26.2)	5	4	9.6 (11)	16.8 (19.2)	22.9 (26.2)	3	2.2	20G11GB015JA0NNNNN	
22 (22)	24.2 (24.2)	33 (33)	7.5	5.5	15.3 (17.5)	24.2 (24.2)	33 (33)	5	4	20G11GB022JA0NNNNN	3
28 (32.2)	30.8 (35.4)	42 (48.3)	10	7.5	22 (22)	33 (35.4)	42 (48.3)	7.5	5.5	20G11GB028JA0NNNNN	
42 (43)	46.2 (47.3)	63 (64.5)	15	11	28 (32.2)	46.2 (48.3)	63 (64.5)	10	7.5	20G11GB042JA0NNNNN	
54 (60)	59.4 (66)	81 (90)	20	15	42 (43)	63 (64.5)	81 (90)	15	11	20G11GB054JA0NNNNN	
70 (78.2)	77 (86)	105 (117)	25	18.5	54 (60)	81 (90)	105 (117)	20	15	20G11GB070JA0NNNNN	5
80 (92)	88 (101)	120 (138)	30	22	70 (78.2)	105 (117)	126 (140)	25	18.5	20G1AGB080JNONNNNN ⁽³⁾	6
104 (120)	114 (132)	156 (180)	40	30	80 (92)	120 (138)	156 (180)	30	22	20G1AGB104JNONNNNN ⁽³⁾	
130 (150)	143 (165)	195 (225)	50	37	104 (120)	156 (180)	195 (225)	40	30	20G1AGB130JNONNNNN ⁽³⁾	
154 (177)	169 (194)	231 (265)	60	45	130 (150)	195 (225)	234 (270)	50	37	20G1AGB154JNONNNNN ⁽³⁾	
192 (221)	211 (243)	288 (331)	75	55	154 (177)	231 (265)	288 (331)	60	45	20G1AGB192JNONNNNN ⁽³⁾	7
260 (260)	286 (286)	390 (390)	100	66	192 (221)	288 (331)	390 (390)	75	55	20G1AGB260JNONNNNN ⁽³⁾	
312 (359)	343 (394)	468 (538)	125	90	260 (260)	390 (394)	468 (538)	100	66	20G1AGB312JNONNNNN ⁽³⁾	
360 (414)	396 (455)	540 (621)	150	110	312 (359)	468 (538)	561 (646)	125	90	20G1AGB360JNONNNNN ⁽³⁾	

- (1) The 5th character determines Input Type; "T" = AC input with precharge and DC terminals, and "A" = AC input with precharge and no DC terminals. For DC input drives, see [DRIVES-5G001](#), the PowerFlex Common Bus Configuration Selection Guide.
- (2) Drive must be programmed to lower voltage to obtain the currents shown in parentheses.
- (3) The 12th character determines whether an internal dynamic braking IGBT is included; "A" = Internal dynamic braking transistor installed, and "N" = No internal dynamic braking transistor.

200...240V AC, Three-phase Drives (Continued)

Note: Frame 6...7 IP00, NEMA Type Open drives can be converted to a flange mount drive (Back/Heatsink: IP66, NEMA/UL Type 4X) with an optional user installed flange kit (kit 20-750-FLNG4-F6 for Frame 6, and kit 20-750-FLNG4-F7 for Frame 7). See page 25 for 200...240V, Frame 6...7 IP00, NEMA Type Open drives.

Flange Mount (Front: IP20, NEMA/UL Type Open; Back/Heatsink: IP66, NEMA/UL Type 4X)

Normal Duty					Heavy Duty					Cat. No. (1)	Frame Size
Output Amps: 240V (208V) (2)			HP	kW	Output Amps: 240V (208V) (2)			HP	kW		
Cont.	60 s	3 s			Cont.	60 s	3 s				
2.2 (2.5)	3.3 (3.7)	3.9 (4.5)	0.5	0.37	2.2 (2.5)	3.3 (3.7)	3.9 (4.5)	0.5	0.37	20G11FB2P2JA0NNNNN	2
4.2 (4.8)	6.3 (7.2)	7.5 (8.6)	1	0.75	4.2 (4.8)	6.3 (7.2)	7.5 (8.6)	1	0.75	20G11FB4P2JA0NNNNN	
6.8 (7.8)	10.2 (11.7)	12.2 (14)	2	1.5	6.8 (7.8)	10.2 (11.7)	12.2 (14)	2	1.5	20G11FB6P8JA0NNNNN	
9.6 (11)	14.4 (16.5)	17.2 (19.8)	3	2.2	9.6 (11)	14.4 (16.5)	17.2 (19.8)	3	2.2	20G11FB9P6JA0NNNNN	
15.3 (17.5)	16.8 (19.2)	22.9 (26.2)	5	4	9.6 (11)	16.8 (19.2)	22.9 (26.2)	3	2.2	20G11FB015JA0NNNNN	
22 (22)	24.2 (24.2)	33 (33)	7.5	5.5	15.3 (17.5)	24.2 (24.2)	33 (33)	5	4	20G11FB022JA0NNNNN	3
28 (32.2)	30.8 (35.4)	42 (48.3)	10	7.5	22 (22)	33 (35.4)	42 (48.3)	7.5	5.5	20G11FB028JA0NNNNN	
42 (43)	46.2 (47.3)	63 (64.5)	15	11	28 (32.2)	46.2 (48.3)	63 (64.5)	10	7.5	20G11FB042JA0NNNNN	
54 (60)	59.4 (66)	81 (90)	20	15	42 (43)	63 (64.5)	81 (90)	15	11	20G11FB054JA0NNNNN	4
70 (78.2)	77 (86)	105 (117)	25	18.5	54 (60)	81 (90)	105 (117)	20	15	20G11FB070JA0NNNNN	5
80 (92)	88 (101)	120 (138)	30	22	70 (78.2)	105 (117)	126 (140)	25	18.5	20G11FB080JA0NNNNN	

(1) The 5th character determines Input Type; "T" = AC input with precharge and DC terminals, and "A" = AC input with precharge and no DC terminals. For DC input drives, see [DRIVES-SG001](#), the PowerFlex Common Bus Configuration Selection Guide.

(2) Drive must be programmed to lower voltage to obtain the currents shown in parentheses.

380...400V AC, Three-phase Drives

IP00/IP20, NEMA/UL Type Open (1)

Light Duty (2)		kW	Normal Duty				Heavy Duty				Cat. No. (3)	Frame Size
Output Amps			Output Amps			kW	Output Amps			kW		
Cont.	60 s		Cont.	60 s	3 s		Cont.	60 s	3 s			
-	-	-	2.1	2.3	3.2	0.75	1.3	2.3	3.2	0.37	20G11RC2P1JA0NNNNN	1
-	-	-	3.5	3.9	5.3	1.5	2.1	3.9	5.3	0.75	20G11RC3P5JA0NNNNN	
-	-	-	5	5.5	7.5	2.2	3.5	5.5	7.5	1.5	20G11RC5P0JA0NNNNN	
-	-	-	8.7	9.6	13.1	4	5	9.6	13.1	2.2	20G11RC8P7JA0NNNNN	
-	-	-	11.5	13.1	17.3	5.5	8.7	13.1	17.3	4	20G11RC011JA0NNNNN	
-	-	-	15.4	16.9	23.1	7.5	11.5	17.2	23.1	5.5	20G11RC015JA0NNNNN	2
-	-	-	2.1	3.1	3.7	0.75	2.1	3.1	3.7	0.75	20G11NC2P1JA0NNNNN	
-	-	-	3.5	5.2	6.3	1.5	3.5	5.2	6.3	1.5	20G11NC3P5JA0NNNNN	
-	-	-	5	7.5	9	2.2	5	7.5	9	2.2	20G11NC5P0JA0NNNNN	
-	-	-	8.7	13	15.6	4	8.7	13.0	15.6	4	20G11NC8P7JA0NNNNN	
-	-	-	11.5	17.2	20.7	5.5	11.5	17.2	20.7	5.5	20G11NC011JA0NNNNN	3
-	-	-	15.4	16.9	23.1	7.5	11.5	17.2	20.7	5.5	20G11NC015JA0NNNNN	
-	-	-	22	24.2	33	11	15.4	24.2	33	7.5	20G11NC022JA0NNNNN	
-	-	-	30	33	45	15	22	33	45	11	20G11NC030JA0NNNNN	
-	-	-	37	40.7	55.5	18.5	30	45	55.5	15	20G11NC037JA0NNNNN	
-	-	-	43	47.3	64.5	22	37	55.5	66.6	18.5	20G11NC043JA0NNNNN	4
-	-	-	60	66	90	30	43	66	90	22	20G11NC060JA0NNNNN	
-	-	-	72	79.2	108	37	60	90	108	30	20G11NC072JA0NNNNN	
-	-	-	85	93.5	128	45	72	108	130	37	20G11NC085JA0NNNNN	
-	-	-	104	114	156	55	85	128	156	45	20G11NC104JA0NNNNN	
-	-	-	140	154	210	75	104	156	210	55	20G11NC140JNONNNNN (4)	6
-	-	-	170	187	255	90	140	210	255	75	20G11NC170JNONNNNN (4)	
-	-	-	205	226	308	110	170	255	308	90	20G11NC205JNONNNNN (4)	
-	-	-	260	286	390	132	205	308	390	110	20G11NC260JNONNNNN (4)	
-	-	-	302	332	453	160	260	390	468	132	20G11NC302JNONNNNN (4)	
-	-	-	367	404	551	200	302	453	551	160	20G11NC367JNONNNNN (4)	7
-	-	-	456	502	684	250	367	551	684	200	20G11NC456JNONNNNN (4)	
-	-	-	477	525	716	270	367	551	684	200	20G11NC477JNONNNNN (4)	

IP00/IP20, NEMA/UL Type Open (Continued) ⁽¹⁾

Light Duty ⁽²⁾			Normal Duty				Heavy Duty				Cat. No. ⁽³⁾	Frame Size
Output Amps		kW	Output Amps			kW	Output Amps			kW		
Cont.	60 s		Cont.	60 s	3 s		Cont.	60 s	3 s			
540	594	315	460	506	690	250	385	578	693	200	20G1A*C460JNONNNNN ⁽⁵⁾	8 ⁽⁶⁾
585	644	315	540	594	810	315	456	684	821	250	20G1A*C540JNONNNNN ⁽⁵⁾	
612	673	355	567	624	851	315	472	708	850	250	20G1A*C567JNONNNNN ⁽⁵⁾	
750	825	400	650	715	975	355	540	810	972	315	20G1A*C650JNONNNNN ⁽⁵⁾	
796	876	450	750	825	1125	400	585	878	1053	315	20G1A*C750JNONNNNN ⁽⁵⁾	
832	915	450	770	847	1155	400	642	963	1156	355	20G1A*C770JNONNNNN ⁽⁵⁾	
1040	1144	560	910	1001	1365	500	750	1125	1350	400	20G11*C910JNONNNNN ⁽⁵⁾	
1090	1199	630	1040	1144	1560	560	880	1320	1584	500	20G11*C1K0JNONNNNN ⁽⁵⁾	9 ⁽⁶⁾
1175	1293	710	1090	1199	1635	630	910	1365	1638	500	20G11*C1K1JNONNNNN ⁽⁵⁾	
1465	1612	800	1175	1293	1763	710	1040	1560	1872	560	20G11*C1K2JNONNNNN ⁽⁵⁾	
1480	1628	850	1465	1612	2198	800	1090	1635	1962	630	20G11*C1K4JNONNNNN ⁽⁵⁾	
1600	1760	900	1480	1628	2220	850	1175	1763	2115	710	20G11*C1K5JNONNNNN ⁽⁵⁾	
1715	1887	1000	1590	1749	2385	900	1325	1988	2385	710	20G11*C1K6JNONNNNN ⁽⁵⁾	10 ⁽⁶⁾
2330	2563	1400	2150	2365	3225	1250	1800	2700	3240	1000	20G11*C2K1JNONNNNN ⁽⁵⁾	

- (1) Frames 1...5 are IP20, NEMA/UL Type Open. Frames 6...7 are IP00, NEMA/UL Type Open. Frames 8...10 are IP20, NEMA/UL Type 1. Frames 1...7 can be converted to IP20, NEMA/UL Type 1 with optional kit (20-750-NEMA1-Fx), where x is the frame size of the drive.
- (2) Light Duty rating only available on Frame 8...10 drives. Light Duty allows 110% overload for 1 minute, and does not have a 3 second overload rating.
- (3) The 5th character determines Input Type; "1" = AC input with precharge and DC terminals, and "A" = AC input with precharge and no DC terminals. For DC input drives, see [DRIVES-SS001](#), the PowerFlex Common Bus Configuration Selection Guide.
- (4) The 12th character determines whether an internal dynamic braking IGBT is included; "A" = Internal dynamic braking transistor installed, and "N" = No internal dynamic braking transistor.
- (5) The 6th character (designated by an * in this table) determines Enclosure Type and Depth. "B" = IP20, NEMA/UL Type 1, MCC style 600 mm (23.6 in.) deep, and "L" = IP20, NEMA/UL Type 1, MCC style 800 mm (31.5 in.).
- (6) A roll-out cart is required with Frame 8...10 drives to assist with power wiring and cabinet mounting. See page [200](#).

380...400V AC, Three-phase Drives (Continued)

IP54, NEMA/UL Type 12

Light Duty ⁽¹⁾			Normal Duty				Heavy Duty				Cat. No. ⁽²⁾	Frame Size	
Output Amps		kW	Output Amps			kW	Output Amps			kW			
Cont.	60 s		Cont.	60 s	3 s		Cont.	60 s	3 s				
-	-	-	2.1	3.1	3.7	0.75	2.1	3.1	3.7	0.75	20G1GC2P1JA0NNNNN	2	
-	-	-	3.5	5.2	6.3	1.5	3.5	5.2	6.3	1.5	20G1GC3P5JA0NNNNN		
-	-	-	5	7.5	9	2.2	5	7.5	9	2.2	20G1GC5P0JA0NNNNN		
-	-	-	8.7	13	15.6	4	8.7	13	15.6	4	20G1GC8P7JA0NNNNN		
-	-	-	11.5	17.2	20.7	5.5	11.5	17.2	20.7	5.5	20G1GC0T1JA0NNNNN		
-	-	-	15.4	16.9	23.1	7.5	11.5	17.2	20.7	5.5	20G1GC015JA0NNNNN		
-	-	-	22	24.2	33	11	15.4	24.2	33	7.5	20G1GC022JA0NNNNN		
-	-	-	30	33	45	15	22	33	45	11	20G1GC030JA0NNNNN	3	
-	-	-	37	40.7	55.5	18.5	30	45	55.5	15	20G1GC037JA0NNNNN		
-	-	-	43	47.3	64.5	22	37	55.5	66.6	18.5	20G1GC043JA0NNNNN	4	
-	-	-	60	66	90	30	43	66	90	22	20G1GC060JA0NNNNN		
-	-	-	72	79.2	108	37	60	90	108	30	20G1GC072JA0NNNNN	5	
-	-	-	85	93.5	128	45	72	108	130	37	20G1GC085JA0NNNNN		
-	-	-	104	114	156	55	85	128	156	45	20G1AGC104JNONNNNN ⁽³⁾	6	
-	-	-	140	154	210	75	104	156	210	55	20G1AGC140JNONNNNN ⁽³⁾		
-	-	-	170	187	255	90	140	210	255	75	20G1AGC170JNONNNNN ⁽³⁾		
-	-	-	205	226	308	110	170	255	308	90	20G1AGC205JNONNNNN ⁽³⁾		
-	-	-	260	286	390	132	205	308	390	110	20G1AGC260JNONNNNN ⁽³⁾	7	
-	-	-	302	332	453	160	260	390	468	132	20G1AGC302JNONNNNN ⁽³⁾		
-	-	-	367	404	551	200	302	453	551	160	20G1AGC367JNONNNNN ⁽³⁾		
-	-	-	456	502	684	250	367	551	684	200	20G1AGC456JNONNNNN ⁽³⁾	8 ⁽⁴⁾	
540	594	315	460	506	690	250	385	578	693	200	20G1AJC460JNONNNNN		
585	644	315	540	594	810	315	456	684	821	250	20G1AJC540JNONNNNN		
612	673	355	567	624	851	315	472	708	850	250	20G1AJC567JNONNNNN		
750	825	400	650	715	975	355	540	810	972	315	20G1AJC650JNONNNNN		
796	876	450	750	825	1125	400	585	878	1053	315	20G1AJC750JNONNNNN		
832	915	450	770	847	1155	400	642	963	1156	355	20G1AJC770JNONNNNN		
1040	1144	560	910	1001	1365	500	750	1125	1350	400	20G1JJC910JNONNNNN		9 ⁽⁴⁾
1090	1199	630	1040	1144	1560	560	880	1320	1584	500	20G1JJC1K0JNONNNNN		
1175	1293	710	1090	1199	1635	630	910	1365	1638	500	20G1JJC1K1JNONNNNN		
1465	1612	800	1175	1293	1763	710	1040	1560	1872	560	20G1JJC1K2JNONNNNN		
1480	1628	850	1465	1612	2198	800	1090	1635	1962	630	20G1JJC1K4JNONNNNN	10 ⁽⁴⁾	
1600	1760	900	1480	1628	2220	850	1175	1763	2115	710	20G1JJC1K5JNONNNNN		
1715	1887	1000	1590	1749	2385	900	1325	1988	2385	710	20G1JJC1K6JNONNNNN		
2330	2563	1400	2150	2365	3225	1250	1800	2700	3240	1000	20G1JJC2K1JNONNNNN		

(1) Light Duty rating only available on Frame 8...10 drives. Light Duty allows 110% overload for 1 minute, and does not have a 3 second overload rating.
 (2) The 5th character determines Input Type; "T" = AC input with precharge and DC terminals, and "A" = AC input with precharge and no DC terminals. For DC input drives, see [DRIVES-S6001](#), the PowerFlex Common Bus Configuration Selection Guide.
 (3) Also available with internal Brake IGBT (20G1xxxxxxANONNNNN).
 (4) A roll-out cart is required with Frame 8...10 drives to assist with power wiring and cabinet mounting. See page [200](#).

380...400V AC, Three-phase Drives (Continued)

Note: Frame 6...7 IP00, NEMA Type Open drives can be converted to a flange mount drive (back/heatsink: IP66, NEMA/UL Type 4X) with an optional user installed flange kit (kit 20-750-FLNG4-F6 for Frame 6, and kit 20-750-FLNG4-F7 for Frame 7). See page 27 for 380...400V, Frame 6...7 IP00, NEMA Type Open drives.

Flange Mount (Front: IP20, NEMA/UL Type Open; Back/Heatsink: IP66, NEMA/UL Type 4X)

Normal Duty				Heavy Duty				Cat. No. (1)	Frame Size
Output Amps			kW	Output Amps			kW		
Cont.	60 s	3 s		Cont.	60 s	3 s			
2.1	3.1	3.7	0.75	2.1	3.1	3.7	0.75	20G11FC2P1JA0NNNNN	2
3.5	5.2	6.3	1.5	3.5	5.2	6.3	1.5	20G11FC3P5JA0NNNNN	
5	7.5	9	2.2	5	7.5	9	2.2	20G11FC5P0JA0NNNNN	
8.7	13	15.6	4	8.7	13	15.6	4	20G11FC8P7JA0NNNNN	
11.5	17.2	20.7	5.5	11.5	17.2	20.7	5.5	20G11FC011JA0NNNNN	
15.4	16.9	23.1	7.5	11.5	17.2	20.7	5.5	20G11FC015JA0NNNNN	
22	24.2	33	11	15.4	24.2	33	7.5	20G11FC022JA0NNNNN	
30	33	45	15	22	33	45	11	20G11FC030JA0NNNNN	3
37	40.7	55.5	18.5	30	45	55.5	15	20G11FC037JA0NNNNN	
43	47.3	64.5	22	37	55.5	66.6	18.5	20G11FC043JA0NNNNN	
60	66	90	30	43	66	90	22	20G11FC060JA0NNNNN	4
72	79.2	108	37	60	90	108	30	20G11FC072JA0NNNNN	
85	93.5	128	45	72	108	130	37	20G11FC085JA0NNNNN	5
104	114	156	55	85	128	156	45	20G11FC104JA0NNNNN	

(1) The 5th character determines Input Type; "1" = AC input with precharge and DC terminals, and "A" = AC input with precharge and no DC terminals. For DC input drives, see [DRIVES-SG001](#), the PowerFlex Common Bus Configuration Selection Guide.

480V AC, Three-phase Drives

IPO0/IP20, NEMA/UL Type Open ⁽¹⁾

Light Duty ⁽²⁾		Hp	Normal Duty				Heavy Duty				Cat. No. ⁽³⁾	Frame Size
Output Amps			Output Amps			Hp	Output Amps			Hp		
Cont.	60 s		Cont.	60 s	3 s		Cont.	60 s	3 s			
-	-	-	2.1	2.3	3.2	1	1.1	2.3	3.2	0.5	20G1RD2P1JAONNNNN	1
-	-	-	3.4	3.7	5.1	2	2.8	4.2	5.1	1	20G1RD3P4JAONNNNN	
-	-	-	5	5.5	7.5	3	3.4	5.5	7.5	2	20G1RD5P0JAONNNNN	
-	-	-	8	8.8	12	5	5	8.8	12	3	20G1RD8P0JAONNNNN	
-	-	-	11	12.1	16.5	7.5	8	12.1	16.5	5	20G1RD0T1JAONNNNN	
-	-	-	14	15.4	21	10	11	16.5	21	7.5	20G1RD014JAONNNNN	
-	-	-	2.1	3.1	3.7	1	2.1	3.1	3.7	1	20G1IND2P1JAONNNNN	2
-	-	-	3.4	5.1	6.1	2	3.4	5.1	6.1	2	20G1IND3P4JAONNNNN	
-	-	-	5	7.5	9	3	5	7.5	9	3	20G1IND5P0JAONNNNN	
-	-	-	8	12	14.4	5	8	12	14.4	5	20G1IND8P0JAONNNNN	
-	-	-	11	16.5	19.8	7.5	11	16.5	19.8	7.5	20G1IND0T1JAONNNNN	
-	-	-	14	15.4	21	10	11	16.5	21	7.5	20G1IND014JAONNNNN	
-	-	-	22	24.2	33	15	14	24.2	33	10	20G1IND022JAONNNNN	3
-	-	-	27	29.7	40.5	20	22	33	40.5	15	20G1IND027JAONNNNN	
-	-	-	34	37.4	51	25	27	40.5	51	20	20G1IND034JAONNNNN	
-	-	-	40	44	60	30	34	51	61.2	25	20G1IND040JAONNNNN	
-	-	-	52	57.2	78	40	40	60	78	30	20G1IND052JAONNNNN	
-	-	-	65	71.5	97.5	50	52	78	97.5	40	20G1IND065JAONNNNN	
-	-	-	77	84.7	116	60	65	97.5	116	50	20G1IND077JAONNNNN	4
-	-	-	96	106	144	75	77	116	144	60	20G1IND096JAONNNNN	
-	-	-	125	138	188	100	96	144	188	75	20G1AND125JNONNNNN ⁽⁴⁾	
-	-	-	156	172	234	125	125	188	234	100	20G1AND156JNONNNNN ⁽⁴⁾	
-	-	-	186	205	279	150	156	234	281	125	20G1AND186JNONNNNN ⁽⁴⁾	
-	-	-	248	273	372	200	186	279	372	150	20G1AND248JNONNNNN ⁽⁴⁾	
-	-	-	302	332	453	250	248	372	453	200	20G1AND302JNONNNNN ⁽⁴⁾	5
-	-	-	361	397	542	300	302	453	535	250	20G1AND361JNONNNNN ⁽⁴⁾	
-	-	-	415	457	623	350	361	542	650	300	20G1AND415JNONNNNN ⁽⁴⁾	
-	-	-	477	525	716	400	361	542	650	300	20G1AND477JNONNNNN ⁽⁴⁾	
485	534	400	430	473	645	350	370	555	666	300	20G1A*D430JNONNNNN ⁽⁵⁾	
545	600	450	485	534	728	400	414	621	745	350	20G1A*D485JNONNNNN ⁽⁵⁾	
590	649	500	545	600	818	450	454	681	817	350	20G1A*D545JNONNNNN ⁽⁵⁾	8 ⁽⁶⁾
710	781	600	617	679	926	500	485	728	873	400	20G1A*D617JNONNNNN ⁽⁵⁾	
765	842	650	710	781	1065	600	545	818	981	450	20G1A*D710JNONNNNN ⁽⁵⁾	
800	880	700	740	814	1110	650	617	926	1111	500	20G1A*D740JNONNNNN ⁽⁵⁾	
960	1056	800	800	880	1200	700	710	1065	1278	600	20G11*D800JNONNNNN ⁽⁵⁾	
1045	1150	900	960	1056	1440	800	795	1193	1431	700	20G11*D960JNONNNNN ⁽⁵⁾	
1135	1249	1000	1045	1150	1568	900	800	1200	1440	750	20G11*D1K0JNONNNNN ⁽⁵⁾	9 ⁽⁶⁾
1365	1502	1100	1135	1249	1703	1000	960	1440	1728	800	20G11*D1K2JNONNNNN ⁽⁵⁾	
1420	1562	1250	1365	1502	2048	1100	1045	1568	1881	900	20G11*D1K3JNONNNNN ⁽⁵⁾	
1540	1694	1350	1420	1562	2130	1250	1135	1703	2043	1000	20G11*D1K4JNONNNNN ⁽⁵⁾	
1655	1821	1500	1525	1678	2288	1350	1270	1905	2286	1100	20G11*D1K5JNONNNNN ⁽⁵⁾	
2240	2464	2000	2070	2277	3105	1750	1730	2595	3114	1650	20G11*D2K0JNONNNNN ⁽⁵⁾	

(1) Frames 1...5 are IP20, NEMA/UL Type Open. Frames 6...7 are IPO0, NEMA/UL Type Open. Frames 8...10 are IP20, NEMA/UL Type 1. Frames 1...7 can be converted to IP20, NEMA/UL Type 1 with optional kit (20-750-NEMA1-Fx), where x is the frame size of the drive.

(2) Light Duty rating only available on Frame 8...10 drives. Light Duty allows 110% overload for 1 minute, and does not have a 3 second overload rating.

(3) The 5th character determines Input Type; "T" = AC input with precharge and DC terminals, and "A" = AC input with precharge and no DC terminals. For DC input drives, see [DRIVES-S6001](#), the PowerFlex Common Bus Configuration Selection Guide.

(4) The 12th character determines whether an internal dynamic braking IGBT is included; "A" = Internal dynamic braking transistor installed, and "N" = No internal dynamic braking transistor.

(5) The 6th character (designated by an * in this table) determines Enclosure Type and Depth. "B" = IP20, NEMA/UL Type 1, MCC style 600 mm (23.6 in.) deep, and "L" = IP20, NEMA/UL Type 1, MCC style 800 mm (31.5 in.).

(6) A roll-out cart is required with Frame 8...10 drives to assist with power wiring and cabinet mounting. See page [200](#).

480V AC, Three-phase Drives (Continued)

IP54, NEMA/UL Type 12

Light Duty ⁽¹⁾		Hp	Normal Duty				Heavy Duty				Cat. No. ⁽²⁾	Frame Size
Output Amps			Output Amps			Hp	Output Amps			Hp		
Cont.	60 s		Cont.	60 s	3 s		Cont.	60 s	3 s			
-	-	-	2.1	3.1	3.7	1	2.1	3.1	3.7	1	20G11GD2P1JA0NNNNN	2
			3.4	5.1	6.1	2	3.4	5.1	6.1	2	20G11GD3P4JA0NNNNN	
			5	7.5	9	3	5	7.5	9	3	20G11GD5P0JA0NNNNN	
			8	12	14.4	5	8	12	14.4	5	20G11GD8P0JA0NNNNN	
			11	16.5	19.8	7.5	11	16.5	19.8	7.5	20G11GD011JA0NNNNN	
			14	15.4	21	10	11	16.5	21	7.5	20G11GD014JA0NNNNN	
			22	24.2	33	15	14	24.2	33	10	20G11GD022JA0NNNNN	
			27	29.7	40.5	20	22	33	40.5	15	20G11GD027JA0NNNNN	3
			34	37.4	51	25	27	40.5	51	20	20G11GD034JA0NNNNN	
			40	44	60	30	34	51	61.2	25	20G11GD040JA0NNNNN	
			52	57.2	78	40	40	60	78	30	20G11GD052JA0NNNNN	4
			65	71.5	97.5	50	52	78	97.5	40	20G11GD065JA0NNNNN	5
			77	84.7	116	60	65	97.5	116	50	20G11GD077JA0NNNNN	
			96	106	144	75	77	116	144	60	20G1AGD096JNONNNNN ⁽³⁾	6
			125	138	188	100	96	144	188	75	20G1AGD125JNONNNNN ⁽³⁾	
			156	172	234	125	125	188	234	100	20G1AGD156JNONNNNN ⁽³⁾	
			186	205	279	150	156	234	281	125	20G1AGD186JNONNNNN ⁽³⁾	
			248	273	372	200	186	279	372	150	20G1AGD248JNONNNNN ⁽³⁾	7
			302	332	453	250	248	372	453	200	20G1AGD302JNONNNNN ⁽³⁾	
			361	397	542	300	302	453	535	250	20G1AGD361JNONNNNN ⁽³⁾	
			415	457	623	350	361	542	650	300	20G1AGD415JNONNNNN ⁽³⁾	
485	534	400	430	473	645	350	370	555	666	300	20G1AJD430JNONNNNN	8 ⁽⁴⁾
545	600	450	485	534	728	400	414	621	745	350	20G1AJD485JNONNNNN	
590	649	500	545	600	818	450	454	681	817	350	20G1AJD545JNONNNNN	
710	781	600	617	679	926	500	485	728	873	400	20G1AJD617JNONNNNN	
765	842	650	710	781	1065	600	545	818	981	450	20G1AJD710JNONNNNN	
800	880	700	740	814	1110	650	617	926	1111	500	20G1AJD740JNONNNNN	9 ⁽⁴⁾
960	1056	800	800	880	1200	700	710	1065	1278	600	20G11JD800JNONNNNN	
1045	1150	900	960	1056	1440	800	795	1193	1431	700	20G11JD960JNONNNNN	
1135	1249	1000	1045	1150	1568	900	800	1200	1440	750	20G11JD1K0JNONNNNN	
1365	1502	1100	1135	1249	1703	1000	960	1440	1728	800	20G11JD1K2JNONNNNN	
1420	1562	1250	1365	1502	2048	1100	1045	1568	1881	900	20G11JD1K3JNONNNNN	10 ⁽⁴⁾
1540	1694	1350	1420	1562	2130	1250	1135	1703	2043	1000	20G11JD1K4JNONNNNN	
1655	1821	1500	1525	1678	2288	1350	1270	1905	2286	1100	20G11JD1K5JNONNNNN	
2240	2464	2000	2070	2277	3105	1750	1730	2595	3114	1650	20G11JD2K0JNONNNNN	

(1) Light Duty rating only available on Frame 8...10 drives. Light Duty allows 110% overload for 1 minute, and does not have a 3 second overload rating.
 (2) The 5th character determines Input Type; "T" = AC input with precharge and DC terminals, and "A" = AC input with precharge and no DC terminals. For DC input drives, see [DRIVES-56001](#), the PowerFlex Common Bus Configuration Selection Guide.
 (3) The 12th character determines whether an internal dynamic braking IGBT is included; "A" = Internal dynamic braking transistor installed, and "N" = No internal dynamic braking transistor.
 (4) A roll-out cart is required with Frame 8...10 drives to assist with power wiring and cabinet mounting. See page [200](#).

480V AC, Three-phase Drives (Continued)

Note: Frame 6...7 IPOO, NEMA Type Open drives can be converted to a flange mount drive (back/heatsink: IP66, NEMA/UL Type 4X) with an optional user installed flange kit (kit 20-750-FLNG4-F6 for Frame 6, and kit 20-750-FLNG4-F7 for Frame 7). See page 31 for 480V, Frame 6...7 IPOO, NEMA Type Open drives.

Flange Mount (Front: IP20, NEMA/UL Type Open; Back/Heatsink: IP66, NEMA/UL Type 4X)

Normal Duty				Heavy Duty				Cat. No. ⁽¹⁾	Frame Size
Output Amps			Hp	Output Amps			Hp		
Cont.	60 s	3 s		Cont.	60 s	3 s			
2.1	3.1	3.7	1	2.1	3.1	3.7	1	20G1FD2P1JAONNNNN	2
3.4	5.1	6.1	2	3.4	5.1	6.1	2	20G1FD3P4JAONNNNN	
5	7.5	9	3	5	7.5	9.0	3	20G1FD5P0JAONNNNN	
8	12	14.4	5	8	12	14.4	5	20G1FD8P0JAONNNNN	
11	16.5	19.8	7.5	11	16.5	19.8	7.5	20G1FD0T1JAONNNNN	
14	15.4	21	10	11	16.5	21	7.5	20G1FD0T4JAONNNNN	
22	24.2	33	15	14	24.2	33	10	20G1FD022JAONNNNN	
27	29.7	40.5	20	22	33	40.5	15	20G1FD027JAONNNNN	3
34	37.4	51	25	27	40.5	51	20	20G1FD034JAONNNNN	
40	44	60	30	34	51	61.2	25	20G1FD040JAONNNNN	
52	57.2	78	40	40	60	78	30	20G1FD052JAONNNNN	4
65	71.5	97.5	50	52	78	97.5	40	20G1FD065JAONNNNN	
77	84.7	116	60	65	97.5	116	50	20G1FD077JAONNNNN	5
96	106	144	75	77	116	144	60	20G1FD096JAONNNNN	

(1) The 5th character determines Input Type; "1" = AC input with precharge and DC terminals, and "A" = AC input with precharge and no DC terminals. For DC input drives, see [DRIVES-SG001](#), the PowerFlex Common Bus Configuration Selection Guide.

600V AC, Three-phase Drives

Frames 3, 4, and 5 are only 600V AC drives. Frames 6 and 7 are dual-voltage drives, and can be operated at 600V or 690V AC.

IMPORTANT Frames 3, 4, and 5 must not be used in common DC input-sharing applications with Frames 6 or larger drives. For more details, contact your local Rockwell Automation sales office or your Allen-Bradley distributor.

IP00/IP20, NEMA/UL Type Open ⁽¹⁾

Light Duty ⁽²⁾		Hp	Normal Duty				Heavy Duty				Cat. No. ⁽³⁾	Frame Size	
Output Amps			Output Amps			Hp	Output Amps			Hp			
Cont.	60 s		Cont.	60 s	3 s		Cont.	60 s	3 s				
-	-	-	1.7	1.9	2.6	1	1.7	1.4	2.6	1	20G1NE1P7JA0NNNNN	3	
-	-	-	2.7	3	4.1	2	1.7	2.6	4.1	1	20G1NE2P7JA0NNNNN		
-	-	-	3.9	4.29	5.85	3	2.7	4.1	5.9	2	20G1NE3P9JA0NNNNN		
-	-	-	6.1	6.7	9.2	5	3.9	5.9	9.2	3	20G1NE6P1JA0NNNNN		
-	-	-	9	9.9	13.5	7.5	6.1	9.2	13.5	5	20G1NE9P0JA0NNNNN		
-	-	-	11	12.1	16.5	10	9	13.5	16.5	7.5	20G1NE011JA0NNNNN		
-	-	-	17	18.7	25.5	15	11	16.5	25.5	10	20G1NE017JA0NNNNN		
-	-	-	22	24.2	33	20	17	25.5	33	15	20G1NE022JA0NNNNN	4	
-	-	-	27	29.7	40.5	25	22	33	40.5	20	20G1NE027JA0NNNNN		
-	-	-	32	35.2	48	30	27	40.5	48.6	25	20G1NE032JA0NNNNN	5	
-	-	-	41	45.1	61.5	40	32	48	61.5	30	20G1NE041JA0NNNNN		
-	-	-	52	57.2	78	50	41	61.5	78	40	20G1NE052JA0NNNNN	6	
-	-	-	12	13.2	18	10	9.1	13.7	18	7.5	20G1ANE012JNONNNNN ⁽⁴⁾		
-	-	-	18	19.8	27	15	12	18	27	10	20G1ANE018JNONNNNN ⁽⁴⁾		
-	-	-	23	25.3	34.5	20	18	27	34.5	15	20G1ANE023JNONNNNN ⁽⁴⁾		
-	-	-	24	26.4	36	20	22	33	39.6	20	20G1ANE024JNONNNNN ⁽⁴⁾		
-	-	-	28	30.8	42	25	23	34.5	42	20	20G1ANE028JNONNNNN ⁽⁴⁾		
-	-	-	33	36.3	49.5	30	28	42	50.4	25	20G1ANE033JNONNNNN ⁽⁴⁾		
-	-	-	42	46.2	63	40	33	49.5	63	30	20G1ANE042JNONNNNN ⁽⁴⁾		
-	-	-	53	58	80	50	42	63	80	40	20G1ANE053JNONNNNN ⁽⁴⁾		
-	-	-	63	69	95	60	52	78	95	50	20G1ANE063JNONNNNN ⁽⁴⁾		
-	-	-	77	85	116	75	63	95	116	60	20G1ANE077JNONNNNN ⁽⁴⁾		
-	-	-	99	109	149	100	77	116	149	75	20G1ANE099JNONNNNN ⁽⁴⁾		
-	-	-	125	138	188	125	99	149	188	100	20G1ANE125JNONNNNN ⁽⁴⁾		
-	-	-	144	158	216	150	125	188	225	125	20G1ANE144JNONNNNN ⁽⁴⁾		
-	-	-	192	211	288	200	144	216	288	150	20G1ANE192JNONNNNN ⁽⁴⁾		7
-	-	-	242	266	363	250	192	288	363	200	20G1ANE242JNONNNNN ⁽⁴⁾		
-	-	-	289	318	434	300	242	363	436	250	20G1ANE289JNONNNNN ⁽⁴⁾		
355	391	350	295	325	443	300	272	408	490	250	20G1A*E295JNONNNNN ⁽⁵⁾	8 ⁽⁶⁾	
395	435	400	355	391	533	350	295	443	531	300	20G1A*E355JNONNNNN ⁽⁵⁾		
435	479	450	395	435	593	400	329	494	592	350	20G1A*E395JNONNNNN ⁽⁵⁾		
460	506	500	435	479	653	450	355	533	639	350	20G1A*E435JNONNNNN ⁽⁵⁾		
510	561	500	460	506	690	500	395	593	711	400	20G1A*E460JNONNNNN ⁽⁵⁾		
545	600	550	510	561	765	500	425	638	765	450	20G1A*E510JNONNNNN ⁽⁵⁾		

IP00/IP20, NEMA/UL Type Open (Continued) ⁽¹⁾

Light Duty ⁽²⁾			Normal Duty				Heavy Duty				Cat. No. ⁽³⁾	Frame Size
Output Amps		Hp	Output Amps			Hp	Output Amps			Hp		
Cont.	60 s		Cont.	60 s	3 s		Cont.	60 s	3 s			
690	759	700	595	655	893	600	510	765	918	500	20G11*E595JNONNNNN ⁽⁵⁾	9 ⁽⁶⁾
760	836	800	630	693	945	700	595	893	1071	600	20G11*E630JNONNNNN ⁽⁵⁾	
835	919	900	760	836	1140	800	630	945	1134	700	20G11*E760JNONNNNN ⁽⁵⁾	
900	990	950	825	908	1238	900	700	1050	1260	750	20G11*E825JNONNNNN ⁽⁵⁾	
980	1078	1000	900	990	1350	950	760	1140	1368	800	20G11*E900JNONNNNN ⁽⁵⁾	
1045	1150	1100	980	1078	1470	1000	815	1223	1467	900	20G11*E980JNONNNNN ⁽⁵⁾	
1220	1342	1200	1110	1221	1665	1100	920	1380	1656	1000	20G11*E1K1JNONNNNN ⁽⁵⁾	10 ⁽⁶⁾
1530	1683	1500	1430	1573	2145	1400	1190	1785	2142	1250	20G11*E1K4JNONNNNN ⁽⁵⁾	

(1) Frames 3...5 are IP20, NEMA/UL Type Open. Frames 6...7 are IP00, NEMA/UL Type Open. Frames 8...10 are IP20, NEMA/UL Type 1. Frames 3...7 can be converted to IP20, NEMA/UL Type 1 with optional kit (20-750-NEMA1-Fx), where x is the frame size of the drive.

(2) Light Duty rating only available on Frame 8...10 drives. Light Duty allows 110% overload for 1 minute, and does not have a 3 second overload rating.

(3) The 5th character determines Input Type; "I" = AC input with precharge and DC terminals, and "A" = AC input with precharge and no DC terminals. For DC input drives, see [DRIVES-SG001](#), the PowerFlex Common Bus Configuration Selection Guide.

(4) The 12th character determines whether an internal dynamic braking IGBT is included; "A" = Internal dynamic braking transistor installed, and "N" = No internal dynamic braking transistor.

(5) The 6th character (designated by an * in this table) determines Enclosure Type and Depth. "B" = IP20, NEMA/UL Type 1, MCC style 600 mm (23.6 in.) deep, and "L" = IP20, NEMA/UL Type 1, MCC style 800 mm (31.5 in.).

(6) A roll-out cart is required with Frame 8...10 drives to assist with power wiring and cabinet mounting. See page [200](#).

600V AC, Three-phase Drives (Continued)

Frames 3, 4, and 5 are only 575...600V AC drives. Frames 6 and 7 are dual-voltage drives, and can be operated at 575...600 V or 660...690V AC.

IMPORTANT Frames 3, 4, and 5 must not be used in common DC input-sharing applications with Frames 6 or larger drives. For more details, contact your local Rockwell Automation sales office or your Allen-Bradley distributor.

IP54, NEMA/UL Type 12

Light Duty ⁽¹⁾			Normal Duty				Heavy Duty				Cat. No. ⁽²⁾	Frame Size
Output Amps		Hp	Output Amps			Hp	Output Amps			Hp		
Cont.	60 s		Cont.	60 s	3 s		Cont.	60 s	3 s			
-	-	-	1.7	1.9	2.6	1	1.7	1.4	2.6	1	20G11GE1P7JA0NNNNN	3
			2.7	3	4.1	2	1.7	2.6	4.1	1	20G11GE2P7JA0NNNNN	
			3.9	4.29	5.85	3	2.7	4.1	5.9	2	20G11GE3P9JA0NNNNN	
			6.1	6.7	9.2	5	3.9	5.9	9.2	3	20G11GE6P1JA0NNNNN	
			9	9.9	13.5	7.5	6.1	9.2	13.5	5	20G11GE9P0JA0NNNNN	
			11	12.1	16.5	10	9	13.5	16.5	7.5	20G11GE0T1JA0NNNNN	
			17	18.7	25.5	15	11	16.5	25.5	10	20G11GE017JA0NNNNN	
			22	24.2	33	20	17	25.5	33	15	20G11GE022JA0NNNNN	
			27	29.7	40.5	25	22	33	40.5	20	20G11GE027JA0NNNNN	4
			32	35.2	48	30	27	40.5	48.6	25	20G11GE032JA0NNNNN	
			41	45.1	61.5	40	32	48	61.5	30	20G11GE041JA0NNNNN	5

IP54, NEMA/UL Type 12 (Continued)

Light Duty ⁽¹⁾			Normal Duty				Heavy Duty				Cat. No. ⁽²⁾	Frame Size
Output Amps		Hp	Output Amps			Hp	Output Amps			Hp		
Cont.	60 s		Cont.	60 s	3 s		Cont.	60 s	3 s			
-	-	-	12	13.2	18	10	9.1	13.7	18	7.5	20G1AGE012JNONNNNN ⁽³⁾	6
-	-	-	18	19.8	27	15	12	18	27	10	20G1AGE018JNONNNNN ⁽³⁾	
-	-	-	23	25.3	34.5	20	18	27	34.5	15	20G1AGE023JNONNNNN ⁽³⁾	
-	-	-	24	26.4	36	20	22	33	39.6	20	20G1AGE024JNONNNNN ⁽³⁾	
-	-	-	28	30.8	42	25	23	34.5	42	20	20G1AGE028JNONNNNN ⁽³⁾	
-	-	-	33	36.3	49.5	30	28	42	50.4	25	20G1AGE033JNONNNNN ⁽³⁾	
-	-	-	42	46.2	63	40	33	49.5	63	30	20G1AGE042JNONNNNN ⁽³⁾	
-	-	-	53	58	80	50	42	63	80	40	20G1AGE053JNONNNNN ⁽³⁾	
-	-	-	63	69	95	60	52	78	95	50	20G1AGE063JNONNNNN ⁽³⁾	
-	-	-	77	85	116	75	63	95	116	60	20G1AGE077JNONNNNN ⁽³⁾	
-	-	-	99	109	149	100	77	116	149	75	20G1AGE099JNONNNNN ⁽³⁾	
-	-	-	125	138	188	125	99	149	188	100	20G1AGE125JNONNNNN ⁽³⁾	
-	-	-	144	158	216	150	125	188	225	125	20G1AGE144JNONNNNN ⁽³⁾	
-	-	-	192	211	288	200	144	216	288	150	20G1AGE192JNONNNNN ⁽³⁾	
-	-	-	242	266	363	250	192	288	363	200	20G1AGE242JNONNNNN ⁽³⁾	
-	-	-	289	318	434	300	242	363	436	250	20G1AGE289JNONNNNN ⁽³⁾	
355	391	350	295	325	443	300	272	408	490	250	20G1AJE295JNONNNNN	8 ⁽⁴⁾
395	435	400	355	391	533	350	295	443	531	300	20G1AJE355JNONNNNN	
435	479	450	395	435	593	400	329	494	592	350	20G1AJE395JNONNNNN	
460	506	500	435	479	653	450	355	533	639	350	20G1AJE435JNONNNNN	
510	561	500	460	506	690	500	395	593	711	400	20G1AJE460JNONNNNN	
545	600	550	510	561	765	500	425	638	765	450	20G1AJE510JNONNNNN	
690	759	700	595	655	893	600	510	765	918	500	20G1JE595JNONNNNN	9 ⁽⁴⁾
760	836	800	630	693	945	700	595	893	1071	600	20G1JE630JNONNNNN	
835	919	900	760	836	1140	800	630	945	1134	700	20G1JE760JNONNNNN	
900	990	950	825	908	1238	900	700	1050	1260	750	20G1JE825JNONNNNN	
980	1078	1000	900	990	1350	950	760	1140	1368	800	20G1JE900JNONNNNN	
1045	1150	1100	980	1078	1470	1000	815	1223	1467	900	20G1JE980JNONNNNN	
1220	1342	1200	1110	1221	1665	1100	920	1380	1656	1000	20G1JE1K1JNONNNNN	10 ⁽⁴⁾
1530	1683	1500	1430	1573	2145	1400	1190	1785	2142	1250	20G1JE1K4JNONNNNN	

(1) Light Duty rating only available on Frame 8...10 drives. Light Duty allows 110% overload for 1 minute, and does not have a 3 second overload rating.
 (2) The 5th character determines Input Type; "I" = AC input with precharge and DC terminals, and "A" = AC input with precharge and no DC terminals. For DC input drives, see [DRIVES-56001](#), the PowerFlex Common Bus Configuration Selection Guide.
 (3) The 12th character determines whether an internal dynamic braking IGBT is included; "A" = Internal dynamic braking transistor installed, and "N" = No internal dynamic braking transistor.
 (4) A roll-out cart is required with Frame 8...10 drives to assist with power wiring and cabinet mounting. See page [200](#).

600V AC, Three-phase Drives (Continued)

Frames 3, 4, and 5 are only 600V AC drives. Frames 6 and 7 are dual-voltage drives, and can be operated at 600V or 690V AC.

IMPORTANT Frames 3, 4, and 5 must not be used in common DC input-sharing applications with Frames 6 or larger drives. For more details, contact your local Rockwell Automation sales office or your Allen-Bradley distributor.

Note: Frame 6...7 IP00, NEMA Type Open drives can be converted to a flange mount drive (back/heatsink: IP66, NEMA/UL Type 4X) with an optional user installed flange kit (kit 20-750-FLNG4-F6 for Frame 6, and kit 20-750-FLNG4-F7 for Frame 7). See page [34](#) for 600V, Frame 6...7 IP00, NEMA Type Open drives.

Flange Mount (Front: IP20, NEMA/UL Type Open; Back/Heatsink: IP66, NEMA/UL Type 4X)

Normal Duty				Heavy Duty				Cat. No. (1)	Frame Size
Output Amps			Hp	Output Amps			Hp		
Cont.	60 s	3 s		Cont.	60 s	3 s			
1.7	1.9	2.6	1	1.7	1.4	2.6	1	20G1FE1P7JAONNNNN	3
2.7	3	4.1	2	1.7	2.6	4.1	1	20G1FE2P7JAONNNNN	
3.9	4.29	5.85	3	2.7	4.1	5.9	2	20G1FE3P9JAONNNNN	
6.1	6.7	9.2	5	3.9	5.9	9.2	3	20G1FE6P1JAONNNNN	
9	9.9	13.5	7.5	6.1	9.2	13.5	5	20G1FE9P0JAONNNNN	
11	12.1	16.5	10	9	13.5	16.5	7.5	20G1FE011JAONNNNN	
17	18.7	25.5	15	11	16.5	25.5	10	20G1FE017JAONNNNN	
22	24.2	33	20	17	25.5	33	15	20G1FE022JAONNNNN	4
27	29.7	40.5	25	22	33	40.5	20	20G1FE027JAONNNNN	
32	35.2	48	30	27	40.5	48.6	25	20G1FE032JAONNNNN	
41	45.1	61.5	40	32	48	61.5	30	20G1FE041JAONNNNN	5
52	57.2	78.0	50	41	61.5	78	40	20G1FE052JAONNNNN	

(1) The 5th character determines Input Type; "T" = AC input with precharge and DC terminals, and "A" = AC input with precharge and no DC terminals. For DC input drives, see [DRIVES-56001](#), the PowerFlex Common Bus Configuration Selection Guide.

690V AC, Three-phase Drives

IP00/IP20, NEMA/UL Type Open (1)

Light Duty (2)			Normal Duty				Heavy Duty				Cat. No. (3)	Frame Size
Output Amps		kW	Output Amps			kW	Output Amps			kW		
Cont.	60 s		Cont.	60 s	3 s		Cont.	60 s	3 s			
-	-	-	12	13.2	18	7.5	9	13.5	18	5.5	20G1ANF012JNONNNNN (4)	6
-	-	-	15	16.5	22.5	11	12	18	22.5	7.5	20G1ANF015JNONNNNN (4)	
-	-	-	20	22	30	15	15	22.5	30	11	20G1ANF020JNONNNNN (4)	
-	-	-	23	25.3	34.5	18.5	20	30	36	15	20G1ANF023JNONNNNN (4)	
-	-	-	30	33	45	22	23	34.5	45	18.5	20G1ANF030JNONNNNN (4)	
-	-	-	34	37.4	51	30	30	45	54	22	20G1ANF034JNONNNNN (4)	
-	-	-	46	50.6	69	37	34	51	69	30	20G1ANF046JNONNNNN (4)	
-	-	-	50	55	75	45	46	69	83	37	20G1ANF050JNONNNNN (4)	
-	-	-	61	67	92	55	50	75	92	45	20G1ANF061JNONNNNN (4)	
-	-	-	82	90	123	75	61	92	123	55	20G1ANF082JNONNNNN (4)	
-	-	-	98	108	147	90	82	123	148	75	20G1ANF098JNONNNNN (4)	
-	-	-	119	131	179	110	98	147	179	90	20G1ANF119JNONNNNN (4)	
-	-	-	142	156	213	132	119	179	214	110	20G1ANF142JNONNNNN (4)	
-	-	-	171	188	257	160	142	213	257	132	20G1ANF171JNONNNNN (4)	7
-	-	-	212	233	318	200	171	257	318	160	20G1ANF212JNONNNNN (4)	
-	-	-	263	289	395	250	212	318	395	200	20G1ANF263JNONNNNN (4)	

IP00/IP20, NEMA/UL Type Open (Continued)⁽¹⁾

Light Duty ⁽²⁾			Normal Duty				Heavy Duty				Cat. No. ⁽³⁾	Frame Size
Output Amps		kW	Output Amps			kW	Output Amps			kW		
Cont.	60 s		Cont.	60 s	3 s		Cont.	60 s	3 s			
330	363	315	265	292	398	250	215	323	387	200	20G1A*F265JNONNNNN ⁽⁵⁾	8 ⁽⁶⁾
370	407	355	330	363	495	315	265	398	477	250	20G1A*F330JNONNNNN ⁽⁵⁾	
410	451	400	370	407	555	355	308	462	554	300	20G1A*F370JNONNNNN ⁽⁵⁾	
460	506	450	415	457	623	400	370	555	666	355	20G1A*F415JNONNNNN ⁽⁵⁾	
500	550	500	460	506	690	450	375	563	675	375	20G1A*F460JNONNNNN ⁽⁵⁾	
530	583	530	500	550	750	500	413	620	743	400	20G1A*F500JNONNNNN ⁽⁵⁾	
650	715	630	590	649	885	560	460	690	828	450	20G11*F590JNONNNNN ⁽⁵⁾	9 ⁽⁶⁾
710	781	710	650	715	975	630	500	750	900	500	20G11*F650JNONNNNN ⁽⁵⁾	
790	869	800	710	781	1065	710	590	885	1062	560	20G11*F710JNONNNNN ⁽⁵⁾	
860	946	850	765	842	1148	750	650	975	1170	630	20G11*F765JNONNNNN ⁽⁵⁾	
960	1056	900	795	875	1193	800	750	1125	1350	710	20G11*F795JNONNNNN ⁽⁵⁾	
1020	1122	1000	960	1056	1440	900	795	1193	1431	800	20G11*F960JNONNNNN ⁽⁵⁾	
1150	1265	1100	1040	1144	1560	1000	865	1298	1557	900	20G11*F1K0JNONNNNN ⁽⁵⁾	10 ⁽⁶⁾
1485	1634	1500	1400	1540	2100	1400	1160	1740	2088	1120	20G11*F1K4JNONNNNN ⁽⁵⁾	

- (1) Frames 6...7 are IP00, NEMA/UL Type Open. Frames 8...10 are IP20, NEMA/UL Type 1. Frames 6...7 can be converted to IP20, NEMA/UL Type 1 with optional kit (20-750-NEMA1-Fx), where x is the frame size.
- (2) Light Duty rating only available on Frame 8...10 drives. Light Duty allows 110% overload for 1 minute, and does not have a 3 second overload rating.
- (3) The 5th character determines Input Type; "I" = AC input with precharge and DC terminals, and "A" = AC input with precharge and no DC terminals. For DC input drives, see [DRIVES-SG001](#), the PowerFlex Common Bus Configuration Selection Guide.
- (4) The 12th character determines whether an internal dynamic braking IGBT is included; "A" = Internal dynamic braking transistor installed, and "N" = No internal dynamic braking transistor.
- (5) The 6th character (designated by an * in this table) determines Enclosure Type and Depth. "B" = IP20, NEMA/UL Type 1, MCC style 600 mm (23.6 in.) deep, and "L" = IP20, NEMA/UL Type 1, MCC style 800 mm (31.5 in.).
- (6) A roll-out cart is required with Frame 8...10 drives to assist with power wiring and cabinet mounting. See page [200](#).

690V AC, Three-phase Drives (Continued)

IP54, NEMA/UL Type 12

Light Duty ⁽¹⁾			Normal Duty				Heavy Duty				Cat. No. ⁽²⁾	Frame Size
Output Amps		kW	Output Amps			kW	Output Amps			kW		
Cont.	60 s		Cont.	60 s	3 s		Cont.	60 s	3 s			
-	-	-	12	13.2	18	7.5	9	13.5	18	5.5	20F1AGF012JNONNNNN ⁽³⁾	6
-	-	-	15	16.5	22.5	11	12	18	22.5	7.5	20F1AGF015JNONNNNN ⁽³⁾	
-	-	-	20	22	30	15	15	22.5	30	11	20F1AGF020JNONNNNN ⁽³⁾	
-	-	-	23	25.3	34.5	18.5	20	30	36	15	20F1AGF023JNONNNNN ⁽³⁾	
-	-	-	30	33	45	22	23	34.5	45	18.5	20F1AGF030JNONNNNN ⁽³⁾	
-	-	-	34	37.4	51	30	30	45	54	22	20F1AGF034JNONNNNN ⁽³⁾	
-	-	-	46	50.6	69	37	34	51	69	30	20F1AGF046JNONNNNN ⁽³⁾	
-	-	-	50	55	75	45	46	69	83	37	20F1AGF050JNONNNNN ⁽³⁾	
-	-	-	61	67	92	55	50	75	92	45	20F1AGF061JNONNNNN ⁽³⁾	
-	-	-	82	90	123	75	61	92	123	55	20F1AGF082JNONNNNN ⁽³⁾	
-	-	-	98	108	147	90	82	123	148	75	20F1AGF098JNONNNNN ⁽³⁾	
-	-	-	119	131	179	110	98	147	179	90	20F1AGF119JNONNNNN ⁽³⁾	
-	-	-	142	156	213	132	119	179	214	110	20F1AGF142JNONNNNN ⁽³⁾	
-	-	-	171	188	257	160	142	213	257	132	20F1AGF171JNONNNNN ⁽³⁾	
-	-	-	212	233	318	200	171	257	318	160	20F1AGF212JNONNNNN ⁽³⁾	
-	-	-	263	289	395	250	212	318	395	200	20F1AGF263JNONNNNN ⁽³⁾	
330	363	315	265	292	398	250	215	323	387	200	20G1AJF265JNONNNNN	8 ⁽⁴⁾
370	407	355	330	363	495	315	265	398	477	250	20G1AJF330JNONNNNN	
410	451	400	370	407	555	355	308	462	554	300	20G1AJF370JNONNNNN	
460	506	450	415	457	623	400	370	555	666	355	20G1AJF415JNONNNNN	
500	550	500	460	506	690	450	375	563	675	375	20G1AJF460JNONNNNN	
530	583	530	500	550	750	500	413	620	743	400	20G1AJF500JNONNNNN	
650	715	630	590	649	885	560	460	690	828	450	20G1JF590JNONNNNN	9 ⁽⁴⁾
710	781	710	650	715	975	630	500	750	900	500	20G1JF650JNONNNNN	
790	869	800	710	781	1065	710	590	885	1062	560	20G1JF710JNONNNNN	
860	946	850	765	842	1148	750	650	975	1170	630	20G1JF765JNONNNNN	
960	1056	900	795	875	1193	800	750	1125	1350	710	20G1JF795JNONNNNN	
1020	1122	1000	960	1056	1440	900	795	1193	1431	800	20G1JF960JNONNNNN	10 ⁽⁴⁾
1150	1265	1100	1040	1144	1560	1000	865	1298	1557	900	20G1JF1K0JNONNNNN	
1485	1634	1500	1400	1540	2100	1400	1160	1740	2088	1120	20G1JF1K4JNONNNNN	

(1) Light Duty rating only available on Frame 8...10 drives. Light Duty allows 110% overload for 1 minute, and does not have a 3 second overload rating.

(2) The 5th character determines Input Type; "I" = AC input with precharge and DC terminals, and "A" = AC input with precharge and no DC terminals. For DC input drives, see [DRIVES-5600](#), the PowerFlex Common Bus Configuration Selection Guide.

(3) The 12th character determines whether an internal dynamic braking IGBT is included; "A" = Internal dynamic braking transistor installed, and "N" = No internal dynamic braking transistor.

(4) A roll-out cart is required with Frame 8...10 drives to assist with power wiring and cabinet mounting. See page [200](#).

Flange Mount (Front: IP20, NEMA/UL Type Open; Back/Heatsink: IP66, NEMA/UL Type 4X)

Note: Frame 6...7 IP00, NEMA Type Open drives can be converted to a flange mount drive (Back/Heatsink: IP66, NEMA/UL Type 4X) with an optional user installed flange kit (20-750-FLNG4-F6 for Frame 6, and 20-750-FLNG4-F7 for Frame 7). See page [37](#) for 690V, Frame 6...7 IP00, NEMA Type Open drives.

Product Selection – PowerFlex 755 Common Bus Drives

540V DC Nominal Input - Common Bus Drives

IP00/IP20, NEMA/UL Type Open ⁽¹⁾

Light Duty ⁽²⁾			Normal Duty				Heavy Duty				Cat. No.	Frame Size
Output Amps		kW	Output Amps			kW	Output Amps			kW		
Cont.	60 s		Cont.	60 s	3 s		Cont.	60 s	3 s			
-	-	-	2.1	2.3	3.2	0.75	1.3	2.3	3.2	0.37	20G11RC2P1JA0NNNNN	1
			3.5	3.9	5.3	1.5	2.1	3.9	5.3	0.75	20G11RC3P5JA0NNNNN	
			5	5.5	7.5	2.2	3.5	5.5	7.5	1.5	20G11RC5P0JA0NNNNN	
			8.7	9.6	13.1	4	5	9.6	13.1	2.2	20G11RC8P7JA0NNNNN	
			11.5	13.1	17.3	5.5	8.7	13.1	17.3	4	20G11RC011JA0NNNNN	
			15.4	16.9	23.1	7.5	11.5	17.2	23.1	5.5	20G11RC015JA0NNNNN	
			2.1	3.1	3.7	0.75	2.1	3.1	3.7	0.75	20G11NC2P1JA0NNNNN	2
			3.5	5.2	6.3	1.5	3.5	5.2	6.3	1.5	20G11NC3P5JA0NNNNN	
			5	7.5	9	2.2	5	7.5	9	2.2	20G11NC5P0JA0NNNNN	
			8.7	13	15.6	4	8.7	13	15.6	4	20G11NC8P7JA0NNNNN	
			11.5	17.2	20.7	5.5	11.5	17.2	20.7	5.5	20G11NC011JA0NNNNN	
			15.4	16.9	23.1	7.5	11.5	17.2	23.1	5.5	20G11NC015JA0NNNNN	
			22	24.2	33	11	15.4	24.2	33	7.5	20G11NC022JA0NNNNN	3
			30	33	45	15	22	33	45	11	20G11NC030JA0NNNNN	
			37	40.7	55.5	18.5	30	45	55.5	15	20G11NC037JA0NNNNN	
			43	47.3	64.5	22	37	55.5	66.6	18.5	20G11NC043JA0NNNNN	
			60	66	90	30	44	66	90	22	20G11NC060JA0NNNNN	4
			72	79.2	108	37	60	90	108	30	20G11NC072JA0NNNNN	
			85	93.5	128	45	72	108	130	37	20G14NC085JA0NNNNN	5
			104	114	156	55	85	128	156	45	20G14NC104JA0NNNNN	
140	154	210	75	104	156	210	55	20G14NC140JNONNNNN ⁽³⁾	6			
170	187	255	90	140	210	255	75	20G14NC170JNONNNNN ⁽³⁾				
205	226	308	110	170	255	308	90	20G14NC205JNONNNNN ⁽³⁾				
260	286	390	132	205	308	390	110	20G14NC260JNONNNNN ⁽³⁾				
302	332	453	160	260	390	468	132	20G14NC302JNONNNNN ⁽³⁾	7			
367	404	551	200	302	453	551	160	20G14NC367JNONNNNN ⁽³⁾				
456	502	684	250	367	551	684	200	20G14NC456JNONNNNN ⁽³⁾				
477	525	716	270	367	551	684	200	20G14NC477JNONNNNN ⁽³⁾				
540	594	315	460	506	690	250	385	578	693	200	21G14*C460JNONNNNN ⁽⁴⁾	8 ⁽⁵⁾
585	644	315	540	594	810	315	456	684	821	250	21G14*C540JNONNNNN ⁽⁴⁾	
612	673	355	567	624	851	315	472	708	850	250	21G14*C567JNONNNNN ⁽⁴⁾	
750	825	400	650	715	975	355	540	810	972	315	21G14*C650JNONNNNN ⁽⁴⁾	
796	876	450	750	825	1125	400	585	878	1053	315	21G14*C750JNONNNNN ⁽⁴⁾	
832	915	450	770	847	1155	400	642	963	1156	355	21G14*C770JNONNNNN ⁽⁴⁾	

IP00/IP20, NEMA/UL Type Open ⁽¹⁾ (Continued)

Light Duty ⁽²⁾			Normal Duty				Heavy Duty				Cat. No.	Frame Size
Output Amps			Output Amps				Output Amps					
Cont.	60 s	kW	Cont.	60 s	3 s	kW	Cont.	60 s	3 s	kW		
1040	1144	560	910	1001	1365	500	750	1125	1350	400	21G14*C910JNONNNNN ⁽⁴⁾	9 ⁽⁵⁾
1090	1199	630	1040	1144	1560	560	880	1320	1584	500	21G14*C1K0JNONNNNN ⁽⁴⁾	
1175	1293	710	1090	1199	1635	630	910	1365	1638	500	21G14*C1K1JNONNNNN ⁽⁴⁾	
1465	1612	800	1175	1293	1763	710	1040	1560	1872	560	21G14*C1K2JNONNNNN ⁽⁴⁾	
1480	1628	850	1465	1612	2198	800	1090	1635	1962	630	21G14*C1K4JNONNNNN ⁽⁴⁾	
1600	1760	900	1480	1628	2220	850	1175	1763	2115	710	21G14*C1K5JNONNNNN ⁽⁴⁾	
1715	1887	1000	1590	1749	2385	900	1325	1988	2385	710	21G14*C1K6JNONNNNN ⁽⁴⁾	10 ⁽⁵⁾
2330	2563	1400	2150	2365	3225	1250	1800	2700	3240	1000	21G14*C2K1JNONNNNN ⁽⁴⁾	

(1) Frames 1...5 are IP20, NEMA/UL Type Open. Frames 6...7 are IP00, NEMA/UL Type Open. Frames 8...10 are IP20, NEMA/UL Type 1. Frames 1...7 can be converted to IP20, NEMA/UL Type 1 with optional kit (20-750-NEMA1-Fx), where x is the frame size of the drive.

(2) Light Duty rating available only on Frame 8...10 drives. Light duty allows 110% overload for 1 minute, and does not have a 3 second overload rating.

(3) The 12th character determines whether an internal dynamic braking IGBT is included; "A" = Internal dynamic braking transistor installed, and "N" = No internal dynamic braking transistor.

(4) The 6th character (designated by an * in this table) determines the enclosure type. Refer to the Enclosure Type table in the [Catalog Number Explanation on page 5](#).

(5) A roll-out cart is required for Frames 8...10 drives to assist with power wiring and cabinet mounting. See page 199.

540V DC Nominal Input - Common Bus Drives (continued)

IP54, NEMA/UL Type 12

Light Duty ⁽¹⁾			Normal Duty				Heavy Duty				Cat. No. ⁽²⁾	Frame Size
Output Amps			Output Amps				Output Amps					
Cont.	60 s	kW	Cont.	60 s	3 s	kW	Cont.	60 s	3 s	kW		
-	-	-	2.1	3.1	3.7	0.75	2.1	3.1	3.7	0.75	20G11GC2P1JAONNNNN	2
-	-	-	3.5	5.2	6.3	1.5	3.5	5.2	6.3	1.5	20G11GC3P5JAONNNNN	
-	-	-	5	7.5	9	2.2	5	7.5	9.0	2.2	20G11GC5P0JAONNNNN	
-	-	-	8.7	13	15.6	4	8.7	13	15.6	4	20G11GC8P7JAONNNNN	
-	-	-	11.5	17.2	20.7	5.5	11.5	17.2	20.7	5.5	20G11GC0T1JAONNNNN	
-	-	-	15.4	16.9	23.1	7.5	11.5	17.2	23.1	5.5	20G11GC015JAONNNNN	
-	-	-	22	24.2	33	11	15.4	24.2	33	7.5	20G11GC022JAONNNNN	
-	-	-	30	33	45	15	22	33	45	11	20G11GC030JAONNNNN	3
-	-	-	37	40.7	55.5	18.5	30	45	55.5	15	20G11GC037JAONNNNN	
-	-	-	43	47.3	64.5	22	37	55.5	66.6	18.5	20G11GC043JAONNNNN	
-	-	-	60	66	90	30	44	66	90	22	20G11GC060JAONNNNN	4
-	-	-	72	79.2	108	37	60	90	108	30	20G14GC072JAONNNNN	5
-	-	-	85	93.5	128	45	72	108	130	37	20G14GC085JAONNNNN	
-	-	-	104	114	156	55	85	128	156	45	20G14GC104JNONNNNN ⁽³⁾	6
-	-	-	140	154	210	75	104	156	210	55	20G14GC140JNONNNNN ⁽³⁾	
-	-	-	170	187	255	90	140	210	255	75	20G14GC170JNONNNNN ⁽³⁾	
-	-	-	205	226	308	110	170	255	308	90	20G14GC205JNONNNNN ⁽³⁾	
-	-	-	260	286	390	132	205	308	390	110	20G14GC260JNONNNNN ⁽³⁾	7
-	-	-	302	332	453	160	260	390	468	132	20G14GC302JNONNNNN ⁽³⁾	
-	-	-	367	404	551	200	302	453	551	160	20G14GC367JNONNNNN ⁽³⁾	
-	-	-	456	502	684	250	367	551	684	200	20G14GC456JNONNNNN ⁽³⁾	
-	-	-										

IP54, NEMA/UL Type 12

540	594	315	460	506	690	250	385	578	693	200	21G14*C460JNONNNNN ⁽⁴⁾	8 ⁽⁵⁾
585	644	315	540	594	810	315	456	684	821	250	21G14*C540JNONNNNN ⁽⁴⁾	
612	673	355	567	624	851	315	472	708	850	250	21G14*C567JNONNNNN ⁽⁴⁾	
750	825	400	650	715	975	355	540	810	972	315	21G14*C650JNONNNNN ⁽⁴⁾	
796	876	450	750	825	1125	400	585	878	1053	315	21G14*C750JNONNNNN ⁽⁴⁾	
832	915	450	770	847	1155	400	642	963	1156	355	21G14*C770JNONNNNN ⁽⁴⁾	9 ⁽⁵⁾
1040	1144	560	910	1001	1365	500	750	1125	1350	400	21G14*C910JNONNNNN ⁽⁴⁾	
1090	1199	630	1040	1144	1560	560	880	1320	1584	500	21G14*C1K0JNONNNNN ⁽⁴⁾	
1175	1293	710	1090	1199	1635	630	910	1365	1638	500	21G14*C1K1JNONNNNN ⁽⁴⁾	
1465	1612	800	1175	1293	1763	710	1040	1560	1872	560	21G14*C1K2JNONNNNN ⁽⁴⁾	
1480	1628	850	1465	1612	2198	800	1090	1635	1962	630	21G14*C1K4JNONNNNN ⁽⁴⁾	10 ⁽⁵⁾
1600	1760	900	1480	1628	2220	850	1175	1763	2115	710	21G14*C1K5JNONNNNN ⁽⁴⁾	
1715	1887	1000	1590	1749	2385	900	1325	1988	2385	710	21G14*C1K6JNONNNNN ⁽⁴⁾	
2330	2563	1400	2150	2365	3225	1250	1800	2700	3240	1000	21G14*C2K1JNONNNNN ⁽⁴⁾	

- (1) Light Duty rating only available on Frame 8...10 drives. Light Duty allows 110% overload for 1 minute, and does not have a 3 second overload rating.
- (2) The 11th character determines default Filtering and Common Mode Cap jumper configuration. "J" = Installed, "A" = Removed.
- (3) The 12th character determines whether an internal dynamic braking IGBT is included; "A" = Internal dynamic braking transistor installed, and "N" = No internal dynamic braking transistor.
- (4) The 6th character (designated by an * in this table) determines the enclosure type. Refer to the Enclosure Type table in the [Catalog Number Explanation on page 5](#).
- (5) A roll-out cart is required with Frame 8...10 drives to assist with power wiring and cabinet mounting. See page [199](#).

540V DC Nominal Input - Common Bus Drives (continued)

IMPORTANT Frame 6...7 IP00, NEMA Type Open drives can be converted to a flange mount drive (Back/Heatsink: IP66, NEMA/UL Type 4X) with an optional user installed flange kit (20-750-FLNG4-F6 for Frame 6, and 20-750-FLNG4-F7 for Frame7). See page [40](#) for 540V DC, Frame 6...7 IP00, NEMA Type Open drives.

Flange Mount (Front: IP20, NEMA/UL Type Open; Back/Heatsink: IP66, NEMA/UL Type 4X)

Normal Duty				Heavy Duty				Cat. No.	Frame Size
Outputs Amp			kW	Output Amps			kW		
Cont.	60 s	3 s		Cont.	60 s	3 s			
2.1	3.1	3.7	0.75	2.1	3.1	3.7	0.75	20G11FC2P1JAONNNNN	2
3.5	5.2	6.3	1.5	3.5	5.2	6.3	1.5	20G11FC3P5JAONNNNN	
5	7.5	9	2.2	5	7.5	9	2.2	20G11FC5P0JAONNNNN	
8.7	13	15.6	4	8.7	13	15.6	4	20G11FC8P7JAONNNNN	
11.5	17.2	20.7	5.5	11.5	17.2	20.7	5.5	20G11FC011JAONNNNN	
15.4	16.9	23.1	7.5	11.5	17.2	23.1	5.5	20G11FC015JAONNNNN	
22	24.2	33	11	15.4	24.2	33	7.5	20G11FC022JAONNNNN	3
30	33	45	15	22	33	45	11	20G11FC030JAONNNNN	
37	40.7	55.5	18.5	30	45	55.5	15	20G11FC037JAONNNNN	
43	47.3	64.5	22	37	55.5	66.6	18.5	20G11FC043JAONNNNN	
60	66	90	30	44	66	90	22	20G11FC060JAONNNNN	
72.0	79.2	108	37	60	90	108	30	20G11FC072JAONNNNN	4
85	93.5	128	45	72	108	130	37	20G14FC085JAONNNNN	5
104	114	156	55	85	128	156	45	20G14FC104JAONNNNN	

650V DC Nominal Input - Common Bus Drives

IPO0/IP20, NEMA/UL Type Open ⁽¹⁾

Light Duty ⁽²⁾			Normal Duty				Heavy Duty				Cat. No.	Frame Size
Output Amps		Hp	Output Amps			Hp	Output Amps			Hp		
Cont.	60 s		Cont.	60 s	3 s		Cont.	60 s	3 s			
-	-	-	2.1	2.3	3.2	1	1.1	2.3	3.2	0.5	20G11RD2P1JAONNNNN	1
			3.4	3.7	5.1	2	2.8	4.2	5.1	1	20G11RD3P4JAONNNNN	
			5	5.5	7.5	3	3.4	5.5	7.5	2	20G11RD5P0JAONNNNN	
			8	8.8	12	5	5	8.8	12	3	20G11RD8P0JAONNNNN	
			11	12.1	16.5	7.5	8	12.1	16.5	5	20G11RD011JAONNNNN	
			14	15.4	21	10	11	16.5	21	7.5	20G11RD014JAONNNNN	
			2.1	3.1	3.7	1	2.1	3.1	3.7	1	20G11ND2P1JAONNNNN	2
			3.4	5.1	6.1	2	3.4	5.1	6.1	2	20G11ND3P4JAONNNNN	
			5	7.5	9.0	3	5	7.5	9	3	20G11ND5P0JAONNNNN	
			8	12	14.4	5	8	12	14.4	5	20G11ND8P0JAONNNNN	
			11	16.5	19.8	7.5	11	16.5	19.8	7.5	20G11ND011JAONNNNN	
			14	15.4	21	10	11	16.5	21	7.5	20G11ND014JAONNNNN	
			22	24.2	33	15	14	24.2	33	15	20G11ND022JAONNNNN	3
			27	29.7	40.5	20	22	33	40.5	15	20G11ND027JAONNNNN	
			34	37.4	51	25	27	40.5	51	20	20G11ND034JAONNNNN	
			40	44	60	30	34	51	61.2	25	20G11ND040JAONNNNN	
			52	57.2	78.0	40	40	60	78	30	20G11ND052JAONNNNN	
			65	71.5	97.5	50	52	78	97.5	40	20G11ND065JAONNNNN	
			77	84.7	116	60	65	97.5	116	50	20G14ND077JAONNNNN	4
			96	106	144	75	77	116	144	60	20G14ND096JAONNNNN	
			125	138	188	100	96	144	188	75	20G14ND125JNONNNNN ⁽³⁾	5
			156	172	234	125	125	188	234	100	20G14ND156JNONNNNN ⁽³⁾	
			186	205	279	150	156	234	281	125	20G14ND186JNONNNNN ⁽³⁾	
			248	273	372	200	186	279	372	150	20G14ND248JNONNNNN ⁽³⁾	
			302	332	453	250	248	372	453	200	20G14ND302JNONNNNN ⁽³⁾	6
			361	397	542	300	302	453	535	250	20G14ND361JNONNNNN ⁽³⁾	
			415	457	623	350	361	542	650	300	20G14ND415JNONNNNN ⁽³⁾	
			477	525	716	400	361	542	650	300	20G14ND477JNONNNNN ⁽³⁾	
485	534	400	430	473	645	350	370	555	666	300	21G14*D430JNONNNNN ⁽⁴⁾	7
545	600	450	485	534	728	400	414	621	745	350	21G14*D485JNONNNNN ⁽⁴⁾	
590	649	500	545	600	818	450	454	681	817	350	21G14*D545JNONNNNN ⁽⁴⁾	
710	781	600	617	679	926	500	485	728	873	400	21G14*D617JNONNNNN ⁽⁴⁾	
765	842	650	710	781	1065	600	545	818	981	450	21G14*D710JNONNNNN ⁽⁴⁾	
800	880	700	740	814	1110	650	617	926	1111	500	21G14*D740JNONNNNN ⁽⁴⁾	
960	1056	800	800	880	1200	700	710	1065	1278	600	21G14*D800JNONNNNN ⁽⁴⁾	8 ⁽⁵⁾
1045	1150	900	960	1056	1440	800	795	1193	1431	700	21G14*D960JNONNNNN ⁽⁴⁾	
1135	1249	1000	1045	1150	1568	900	800	1200	1440	750	21G14*D1K0JNONNNNN ⁽⁴⁾	
1365	1502	1100	1135	1249	1703	1000	960	1440	1728	800	21G14*D1K2JNONNNNN ⁽⁴⁾	
1420	1562	1250	1365	1502	2048	1100	1045	1568	1881	900	21G14*D1K3JNONNNNN ⁽⁴⁾	9 ⁽⁵⁾
1540	1694	1350	1420	1562	2130	1250	1135	1703	2043	1000	21G14*D1K4JNONNNNN ⁽⁴⁾	
1655	1821	1500	1525	1678	2288	1350	1270	1905	2286	1100	21G14*D1K5JNONNNNN ⁽⁴⁾	
2240	2464	2000	2070	2277	3105	1750	1730	2595	3114	1650	21G14*D2K0JNONNNNN ⁽⁴⁾	

(1) Frames 1...5 are IP20, NEMA/UL Type Open. Frames 6...7 are IPO0, NEMA/UL Type Open. Frames 8...10 are IP20, NEMA/UL Type 1. Frames 1...7 can be converted to IP20, NEMA/UL Type 1 with optional kit (20-750-NEMA1-Fx), where x is the frame size of the drive.

- (2) Light Duty rating only available on Frame 8...10 drives. Light Duty allows 110% overload for 1 minute, and does not have a 3 second overload rating.
- (3) The 12th character determines whether an internal dynamic braking IGBT is included; "A" = Internal dynamic braking transistor installed, and "N" = No internal dynamic braking transistor.
- (4) The 6th character (designated by an * in this table) determines the enclosure type. Refer to the Enclosure Type table in the [Catalog Number Explanation on page 5](#).
- (5) A roll-out cart is required with Frame 8...10 drives to assist with power wiring and cabinet mounting. See page [199](#).

650V DC Nominal Input - Common Bus Drives (continued)

IP54, NEMA/UL Type 12

Light Duty ⁽¹⁾			Normal Duty				Heavy Duty				Cat. No.	Frame Size
Output Amps		Hp	Output Amps			Hp	Output Amps			Hp		
Cont.	60 s		Cont.	60 s	3 s		Cont.	60 s	3 s			
-	-	-	2.1	3.1	3.7	1	2.1	3.1	3.7	1	20G11GD2P1JA0N0N0N0N	2
			3.4	5.1	6.1	2	3.4	5.1	6.1	2	20G11GD3P4JA0N0N0N0N	
			5	7.5	9	3	5	7.5	9	3	20G11GD5P0JA0N0N0N0N	
			8	12	14.4	5	8	12	14.4	5	20G11GD8P0JA0N0N0N0N	
			11	16.5	19.8	7.5	11	16.5	19.8	7.5	20G11GD0T1JA0N0N0N0N	
			14	15.4	21	10	11	16.5	21	7.5	20G11GD0T4JA0N0N0N0N	
			22	24.2	33	15	14	24.2	33	15	20G11GD022JA0N0N0N0N	
			27	29.7	40.5	20	22	33	40.5	15	20G11GD027JA0N0N0N0N	3
			34	37.4	51	25	27	40.5	51	20	20G11GD034JA0N0N0N0N	
			40	44	60	30	34	51	61.2	25	20G11GD040JA0N0N0N0N	
			52	57.2	78	40	40	60	78	30	20G11GD052JA0N0N0N0N	4
			65	71.5	97.5	50	52	78	97.5	40	20G14GD065JA0N0N0N0N	5
			77	84.7	116	60	65	97.5	116	50	20G14GD077JA0N0N0N0N	
			96	106	144	75	77	116	144	60	20G14GD096JN0N0N0N0N ⁽²⁾	6
			125	138	188	100	96	144	188	75	20G14GD125JN0N0N0N0N ⁽²⁾	
			156	172	234	125	125	188	234	100	20G14GD156JN0N0N0N0N ⁽²⁾	
			186	205	279	150	156	234	281	125	20G14GD186JN0N0N0N0N ⁽²⁾	
			248	273	372	200	186	279	372	150	20G14GD248JN0N0N0N0N ⁽²⁾	7
			302	332	453	250	248	372	453	200	20G14GD302JN0N0N0N0N ⁽²⁾	
			361	397	542	300	302	453	535	250	20G14GD361JN0N0N0N0N ⁽²⁾	
			415	457	623	350	361	542	650	300	20G14GD415JN0N0N0N0N ⁽²⁾	
485	534	400	430	473	645	350	370	555	666	300	21G14*D430JN0N0N0N0N ⁽³⁾	8 ⁽⁴⁾
545	600	450	485	534	728	400	414	621	745	350	21G14*D485JN0N0N0N0N ⁽³⁾	
590	649	500	545	600	818	450	454	681	817	350	21G14*D545JN0N0N0N0N ⁽³⁾	
710	781	600	617	679	926	500	485	728	873	400	21G14*D617JN0N0N0N0N ⁽³⁾	
765	842	650	710	781	1065	600	545	818	981	450	21G14*D710JN0N0N0N0N ⁽³⁾	
800	880	700	740	814	1110	650	617	926	1111	500	21G14*D740JN0N0N0N0N ⁽³⁾	

IP54, NEMA/UL Type 12

Light Duty ⁽¹⁾			Normal Duty				Heavy Duty				Cat. No.	Frame Size
Output Amps		Hp	Output Amps			Hp	Output Amps			Hp		
Cont.	60 s		Cont.	60 s	3 s		Cont.	60 s	3 s			
960	1056	800	800	880	1200	700	710	1065	1278	600	21G14*D800JNONNNNN ⁽³⁾	g ⁽⁴⁾
1045	1150	900	960	1056	1440	800	795	1193	1431	700	21G14*D960JNONNNNN ⁽³⁾	
1135	1249	1000	1045	1150	1568	900	800	1200	1440	750	21G14*D1K0JNONNNNN ⁽³⁾	
1365	1502	1100	1135	1249	1703	1000	960	1440	1728	800	21G14*D1K2JNONNNNN ⁽³⁾	
1420	1562	1250	1365	1502	2048	1100	1045	1568	1881	900	21G14*D1K3JNONNNNN ⁽³⁾	
1540	1694	1350	1420	1562	2130	1250	1135	1703	2043	1000	21G14*D1K4JNONNNNN ⁽³⁾	
1655	1821	1500	1525	1678	2288	1350	1270	1905	2286	1100	21G14*D1K5JNONNNNN ⁽³⁾	10 ⁽⁴⁾
2240	2464	2000	2070	2277	3105	1750	1730	2595	3114	1650	21G14*D2K0JNONNNNN ⁽³⁾	

(1) Light Duty rating available only on Frame 8...10 drives. Light Duty allows 110% overload for 1 minute, and does not have a 3 second overload rating.

(2) The 12th character determines whether an internal dynamic braking IGBT is included; "A" = Internal dynamic braking transistor installed, and "N" = No internal dynamic braking transistor.

(3) The 6th character (designated by an * in this table) determines the enclosure type. Refer to the Enclosure Type table in the [Catalog Number Explanation on page 5](#).

(4) A roll-out cart is required with Frame 8...10 drives to assist with power wiring and cabinet mounting. See page 199.

650V DC Nominal Input - Common Bus Drives (continued)

IMPORTANT Frame 6...7 IP00, NEMA Type Open drives can be converted to a flange mount drive (Back/Heatsink: IP66, NEMA/UL Type 4X) with an optional user installed flange kit (20-750-FLNG4-F6 for Frame 6, and 20-750-FLNG4-F7 for Frame7). See page 43 for 650V DC, Frame 6...7 IP00, NEMA Type Open drives.

Flange Mount (Front: IP20, NEMA/UL Type Open; Back/Heatsink: IP66, NEMA/UL Type 4X)

Normal Duty				Heavy Duty				Cat. No. ⁽¹⁾	Frame Size
Output Amps			Hp	Output Amps			Hp		
Cont.	60 s	3 s		Cont.	60 s	3 s			
2.1	3.1	3.7	1	2.1	3.1	3.7	1	20G11FD2P1JAONNNNN	2
3.4	5.1	6.1	2	3.4	5.1	6.1	2	20G11FD3P4JAONNNNN	
5	7.5	9	3	5	7.5	9	3	20G11FD5P0JAONNNNN	
8	12	14.4	5	8	12	14.4	5	20G11FD8P0JAONNNNN	
11	16.5	19.8	7.5	11	16.5	19.8	7.5	20G11FD011JAONNNNN	
14	15.4	21	10	11	16.5	21	7.5	20G11FD014JAONNNNN	
22	24.2	33	15	14	24.2	33	15	20G11FD022JAONNNNN	
27	29.7	40.5	20	22	33	40.5	15	20G11FD027JAONNNNN	3
34	37.4	51	25	27	40.5	51	20	20G11FD034JAONNNNN	
40	44	60	30	34	51	61.2	25	20G11FD040JAONNNNN	
52.0	57.2	78	40	40	60	78	30	20G11FD052JAONNNNN	4
65.0	71.5	97.5	50	52	78	97.5	40	20G11FD065JAONNNNN	
77	84.7	116	60	65	97.5	116	50	20G14FD077JAONNNNN	5
96	106	144	75	77	116	144	60	20G14FD096JAONNNNN	

(1) The 11th character determines default Filtering and Common Mode Cap jumper configuration. "J" = Installed, "A" = Removed.

810V DC Nominal Input - Common Bus Drives

IMPORTANT At 810V DC, PowerFlex 750-series Frames 3...5 drives cannot be used on the same common DC bus as 810/932V DC PowerFlex 750-series Frames 6...10 drives. For more details, contact your local Rockwell Automation salesoffice or your Allen-Bradley distributor.

IP00/IP20, NEMA/UL Type Open ⁽¹⁾

Light Duty ⁽²⁾			Normal Duty				Heavy Duty				Cat. No.	Frame Size
Outputs Amp		Hp	Outputs Amp			Hp	Output Amps			Hp		
Cont.	60 s		Cont.	60 s	3 s		Cont.	60 s	3 s			
-	-	-	1.7	1.9	2.6	1	1.7	1.4	2.6	1	20G1NE1P7JAONNNNN	3
			2.7	3	4.1	2	1.7	2.6	4.1	2	20G1NE2P7JAONNNNN	
			3.9	4.29	5.85	3	2.7	4.1	5.9	3	20G1NE3P9JAONNNNN	
			6.1	6.7	9.2	5	3.9	5.9	9.2	5	20G1NE6P1JAONNNNN	4
			9	9.9	13.5	7.5	6.1	9.2	13.5	7.5	20G1NE9P0JAONNNNN	
			11	12.1	16.5	10	9	13.5	16.5	10	20G1NE0T1JAONNNNN	
			17	18.7	25.5	15	11	16.5	25.5	15	20G1NE0T7JAONNNNN	5
			22	24.2	33	20	17	25.5	33	20	20G1NE022JAONNNNN	
			27	29.7	40.5	25	22	33	40.5	25	20G1NE027JAONNNNN	
			32	35.2	48	30	27	40.5	48.6	30	20G1NE032JAONNNNN	6
			41	45.1	61.5	40	32	48	61.5	40	20G14NE041JAONNNNN	
			52	57.2	78	50	41	61.5	78	40	20G14NE052JAONNNNN	
			12	13.2	18	10	9.1	13.7	18	7.5	20G14NE012JNONNNNN ⁽³⁾	7
			18	19.8	27	15	12	18	27	10	20G14NE018JNONNNNN ⁽³⁾	
			23	25.3	34.5	20	18	27	34.5	15	20G14NE023JNONNNNN ⁽³⁾	
			24	26.4	36	20	22	33	39.6	20	20G14NE024JNONNNNN ⁽³⁾	
			28	30.8	42	25	23	34.5	42	20	20G14NE028JNONNNNN ⁽³⁾	
			33	36.3	49.5	30	28	42	50.4	25	20G14NE033JNONNNNN ⁽³⁾	
			42	46.2	63	40	33	49.5	63	30	20G14NE042JNONNNNN ⁽³⁾	
			53	58	80	50	42	63	80	40	20G14NE053JNONNNNN ⁽³⁾	
			63	69	95	60	52	78	95	50	20G14NE063JNONNNNN ⁽³⁾	
			77	85	116	75	63	95	116	50	20G14NE077JNONNNNN ⁽³⁾	
			99	109	149	100	77	116	149	60	20G14NE099JNONNNNN ⁽³⁾	8 ⁽⁵⁾
			125	138	188	125	99	149	188	75	20G14NE125JNONNNNN ⁽³⁾	
			144	158	216	150	125	188	225	100	20G14NE144JNONNNNN ⁽³⁾	
			192	211	288	200	144	216	288	125	20G14NE192JNONNNNN ⁽³⁾	9 ⁽⁵⁾
			242	266	363	250	192	288	363	150	20G14NE242JNONNNNN ⁽³⁾	
			289	318	434	300	242	363	436	200	20G14NE289JNONNNNN ⁽³⁾	
355	391	350	295	325	443	300	272	408	490	250	21G14*E295JNONNNNN ⁽⁴⁾	10 ⁽⁵⁾
395	435	400	355	391	533	350	295	443	531	300	21G14*E355JNONNNNN ⁽⁴⁾	
435	479	450	395	435	593	400	329	494	592	350	21G14*E395JNONNNNN ⁽⁴⁾	
460	506	500	435	479	653	450	355	533	639	350	21G14*E435JNONNNNN ⁽⁴⁾	10 ⁽⁵⁾
510	561	500	460	506	690	500	395	593	711	400	21G14*E460JNONNNNN ⁽⁴⁾	
545	600	550	510	561	765	500	425	638	765	450	21G14*E510JNONNNNN ⁽⁴⁾	
690	759	700	595	655	893	600	510	765	918	500	21G14*E595JNONNNNN ⁽⁴⁾	9 ⁽⁵⁾
760	836	800	630	693	945	700	595	893	1071	600	21G14*E630JNONNNNN ⁽⁴⁾	
835	919	900	760	836	1140	800	630	945	1134	700	21G14*E760JNONNNNN ⁽⁴⁾	
900	990	950	825	908	1238	900	700	1050	1260	750	21G14*E825JNONNNNN ⁽⁴⁾	10 ⁽⁵⁾
980	1078	1000	900	990	1350	950	760	1140	1368	800	21G14*E900JNONNNNN ⁽⁴⁾	
1045	1150	1100	980	1078	1470	1000	815	1223	1467	900	21G14*E980JNONNNNN ⁽⁴⁾	
1220	1342	1200	1110	1221	1665	1100	920	1380	1656	1000	21G14*E1K1JNONNNNN ⁽⁴⁾	10 ⁽⁵⁾
1530	1683	1500	1430	1573	2145	1400	1190	1785	2142	1250	21G14*E1K4JNONNNNN ⁽⁴⁾	

(1) Frames 3...5 are IP20, NEMA/UL Type Open. Frames 6...7 are IP00, NEMA/UL Type Open. Frames 8...10 are IP20, NEMA/UL Type 1. Frames 3...7 can be converted to IP20, NEMA/UL Type 1 with optional kit (20-750-NEMA1-Fx), where x is the frame size of the drive.

(2) Light Duty rating only available on Frame 8...10 drives. Light Duty allows 110% overload for 1 minute, and does not have a 3 second overload rating.

(3) The 12th character determines whether an internal dynamic braking IGBT is included; "A" = Internal dynamic braking transistor installed, and "N" = No internal dynamic braking transistor.

(4) The 6th character (designated by an * in this table) determines the enclosure type. Refer to the Enclosure Type table in the [Catalog Number Explanation on page 5](#).

(5) A roll-out cart is required with Frame 8...10 drives to assist with power wiring and cabinet mounting. See page 199.

810V DC Nominal Input - Common Bus Drives (continued)

IMPORTANT At 810V DC, PowerFlex 750-series Frames 3...5 drives cannot be used on the same common DC bus as 810/932V DC PowerFlex 750-series Frames 6...10 drives. For more details, contact your local Rockwell Automation sales office or your Allen-Bradley distributor.

IP54, NEMA/UL Type 12

Light Duty ⁽¹⁾			Normal Duty				Heavy Duty				Cat. No.	Frame Size
Output Amps		Hp	Output Amps			Hp	Output Amps			Hp		
Cont.	60 s		Cont.	60 s	3 s		Cont.	60 s	3 s			
-	-	-	1.7	1.9	2.6	1	1.7	1.4	2.6	1	20G11GE1P7JAONNNNN	3
			2.7	3	4.1	2	1.7	2.6	4.1	1	20G11GE2P7JAONNNNN	
			3.9	4.29	5.85	3	2.7	4.1	5.9	2	20G11GE3P9JAONNNNN	
			6.1	6.7	9.2	5	3.9	5.9	9.2	3	20G11GE6P1JAONNNNN	
			9	9.9	13.5	7.5	6.1	9.2	13.5	5	20G11GE9P0JAONNNNN	
			11	12.1	16.5	10	9	13.5	16.5	7.5	20G11GE0T1JAONNNNN	
			17	18.7	25.5	15	11	16.5	25.5	10	20G11GE0T7JAONNNNN	
			22	24.2	33	20	17	25.5	33	15	20G11GE022JAONNNNN	
			27	29.7	40.5	25	22	33	40.5	20	20G11GE027JAONNNNN	4
			32	35.2	48	30	27	40.5	48.6	25	20G11GE032JAONNNNN	
			41	45.1	61.5	40	32.0	48	61.5	30	20G14GE041JAONNNNN	5
			12	13.2	18	10	9.1	13.7	18	7.5	20G14GE012JNONNNNN ⁽²⁾	6
			18	19.8	27	15	12	18	27	10	20G14GE018JNONNNNN ⁽²⁾	
			23	25.3	34.5	20	18	27	34.5	15	20G14GE023JNONNNNN ⁽²⁾	
			24	26.4	36	20	22	33	39.6	20	20G14GE024JNONNNNN ⁽²⁾	
			28	30.8	42	25	23	34.5	42	20	20G14GE028JNONNNNN ⁽²⁾	
			33	36.3	49.5	30	28	42	50.4	25	20G14GE033JNONNNNN ⁽²⁾	
			42	46.2	63	40	33	49.5	63	30	20G14GE042JNONNNNN ⁽²⁾	
			53	58	80	50	42	63	80	40	20G14GE053JNONNNNN ⁽²⁾	
			63	69	95	60	52	78	95	50	20G14GE063JNONNNNN ⁽²⁾	
			77	85	116	75	63	95	116	50	20G14GE077JNONNNNN ⁽²⁾	
			99	109	149	100	77	116	149	60	20G14GE099JNONNNNN ⁽²⁾	
			125	138	188	125	99	149	188	75	20G14GE125JNONNNNN ⁽²⁾	
			144	158	216	150	125	188	225	100	20G14GE144JNONNNNN ⁽²⁾	7
			192	211	288	200	144	216	288	125	20G14GE192JNONNNNN ⁽²⁾	
			242	266	363	250	192	288	363	150	20G14GE242JNONNNNN ⁽²⁾	
			289	318	434	300	242	363	436	200	20G14GE289JNONNNNN ⁽²⁾	
355	391	350	295	325	443	300	272	408	490	250	21G14*E295JNONNNNN ⁽³⁾	8 ⁽⁴⁾
395	435	400	355	391	533	350	295	443	531	300	21G14*E355JNONNNNN ⁽³⁾	
435	479	450	395	435	593	400	329	494	592	350	21G14*E395JNONNNNN ⁽³⁾	
460	506	500	435	479	653	450	355	533	639	350	21G14*E435JNONNNNN ⁽³⁾	
510	561	500	460	506	690	500	395	593	711	400	21G14*E460JNONNNNN ⁽³⁾	
545	600	550	510	561	765	500	425	638	765	450	21G14*E510JNONNNNN ⁽³⁾	

IP54, NEMA/UL Type 12

Light Duty ⁽¹⁾			Normal Duty				Heavy Duty				Cat. No.	Frame Size
Output Amps		Hp	Output Amps			Hp	Output Amps			Hp		
Cont.	60 s		Cont.	60 s	3 s		Cont.	60 s	3 s			
690	759	700	595	655	893	600	510	765	918	500	21G14*E595JNONNNNN ⁽³⁾	9 ⁽⁴⁾
760	836	800	630	693	945	700	595	893	1071	600	21G14*E630JNONNNNN ⁽³⁾	
835	919	900	760	836	1140	800	630	945	1134	700	21G14*E760JNONNNNN ⁽³⁾	
900	990	950	825	908	1238	900	700	1050	1260	750	21G14*E825JNONNNNN ⁽³⁾	
980	1078	1000	900	990	1350	950	760	1140	1368	800	21G14*E900JNONNNNN ⁽³⁾	
1045	1150	1100	980	1078	1470	1000	815	1223	1467	900	21G14*E980JNONNNNN ⁽³⁾	
1220	1342	1200	1110	1221	1665	1100	920	1380	1656	1000	21G14*E1K1JNONNNNN ⁽³⁾	10 ⁽⁴⁾
1530	1683	1500	1430	1573	2145	1400	1190	1785	2142	1250	21G14*E1K4JNONNNNN ⁽³⁾	

- (1) Light Duty rating only available on Frame 8...10 drives. Light Duty allows 110% overload for 1 minute, and does not have a 3 second overload rating.
- (2) The 12th character determines whether an internal dynamic braking IGBT is included; "A" = Internal dynamic braking transistor installed, and "N" = No internal dynamic braking transistor.
- (3) The 6th character (designated by an * in this table) determines the enclosure type. Refer to the Enclosure Type table in the [Catalog Number Explanation on page 5](#).
- (4) A roll-out cart is required with Frame 8...10 drives to assist with power wiring and cabinet mounting. See page [199](#).

810V DC Nominal Input - Common Bus Drives (continued)

- IMPORTANT** At 810V DC, PowerFlex 750-series Frames 3...5 drives cannot be used on the same common DC bus as 810/932V DC PowerFlex 750-series Frames 6...10 drives. For more details, contact your local Rockwell Automation sales office or your Allen-Bradley distributor.
- IMPORTANT** Frame 6...7 IP00, NEMA Type Open drives can be converted to a flange mount drive (back/heatsink: IP66, NEMA/UL Type 4X) with an optional user installed flange kit (kit 20-750-FLNG4-F6 for Frame 6, and kit 20-750-FLNG4-F7 for Frame 7). See page [46](#) for 810V DC, Frame 6...7 IP00, NEMA Type Open drives.

Flange Mount (Front: IP20, NEMA/UL Type Open; Back/Heatsink: IP66, NEMA/UL Type 4X)

Normal Duty				Heavy Duty				Cat. No. ⁽¹⁾	Frame Size
Outputs Amp			Hp	Output Amps			Hp		
Cont.	60 s	3 s		Cont.	60 s	3 s			
1.7	1.9	2.6	1	1.7	1.4	2.6	1	20G11FE1P7JA0NNNNN	3
2.7	3	4.1	2	1.7	2.6	4.1	1	20G11FE2P7JA0NNNNN	
3.9	4.29	5.85	3	2.7	4.1	5.9	2	20G11FE3P9JA0NNNNN	
6.1	6.7	9.2	5	3.9	5.9	9.2	3	20G11FE6P1JA0NNNNN	
9	9.9	13.5	7.5	6.1	9.2	13.5	5	20G11FE9P0JA0NNNNN	
11	12.1	16.5	10	9	13.5	16.5	7.5	20G11FE011JA0NNNNN	
17	18.7	25.5	15	11	16.5	25.5	10	20G11FE017JA0NNNNN	
22	24.2	33	20	17	25.5	33	15	20G11FE022JA0NNNNN	
27	29.7	40.5	25	22	33	40.5	20	20G11FE027JA0NNNNN	4
32	35.2	48	30	27	40.5	48.6	25	20G11FE032JA0NNNNN	
41	45.1	61.5	40	32	48	61.5	30	20G14FE041JA0NNNNN	5
52	57.2	78	50	41	61.5	78.0	40	20G14FE052JA0NNNNN	

- (1) The 11th character determines default Filtering and Common Mode Cap jumper configuration. "J" = Installed, "A" = Removed.

932V DC Nominal Input - Common Bus Drives

IP00/IP20, NEMA/UL Type Open ⁽¹⁾

Light Duty ⁽²⁾			Normal Duty				Heavy Duty				Cat. No.	Frame Size
Output Amps		kW	Output Amps			kW	Output Amps			kW		
Cont.	60 s		Cont.	60 s	3 s		Cont.	60 s	3 s			
-	-	-	12	13.2	18	7.5	9	13.5	18	5.5	20G14NF012JNONNNNN ⁽³⁾	6
			15	16.5	22.5	11	12	18	22.5	7.5	20G14NF015JNONNNNN ⁽³⁾	
			20	22	30	15	15	22.5	30	11	20G14NF020JNONNNNN ⁽³⁾	
			23	25.3	34.5	18.5	20	30	36	15	20G14NF023JNONNNNN ⁽³⁾	
			30	33	45	22	23	34.5	45	18.5	20G14NF030JNONNNNN ⁽³⁾	
			34	37.4	51	30	30	45	54	22	20G14NF034JNONNNNN ⁽³⁾	
			46	50.6	69	37	34	51	69	30	20G14NF046JNONNNNN ⁽³⁾	
			50	55	75	45	46	69	83	37	20G14NF050JNONNNNN ⁽³⁾	
			61	67	92	55	50	75	92	45	20G14NF061JNONNNNN ⁽³⁾	
			82	90	123	75	61	92	123	55	20G14NF082JNONNNNN ⁽³⁾	
			98	108	147	90	82	123	148	75	20G14NF098JNONNNNN ⁽³⁾	
			119	131	179	110	98	147	179	90	20G14NF119JNONNNNN ⁽³⁾	
			142	156	213	132	119	179	214	110	20G14NF142JNONNNNN ⁽³⁾	
			171	188	257	160	142	213	257	132	20G14NF171JNONNNNN ⁽³⁾	
			212	233	318	200	171	257	318	160	20G14NF212JNONNNNN ⁽³⁾	
			263	289	395	250	212	318	395	200	20G14NF263JNONNNNN ⁽³⁾	
330	363	315	265	292	398	250	215	323	387	200	21G14*F265JNONNNNN ⁽⁴⁾	8 ⁽⁵⁾
370	407	355	330	363	495	315	265	398	477	250	21G14*F330JNONNNNN ⁽⁴⁾	
410	451	400	370	407	555	355	308	462	554	300	21G14*F370JNONNNNN ⁽⁴⁾	
460	506	450	415	457	623	400	370	555	666	355	21G14*F415JNONNNNN ⁽⁴⁾	
500	550	500	460	506	690	450	375	563	675	375	21G14*F460JNONNNNN ⁽⁴⁾	
530	583	530	500	550	750	500	413	620	743	400	21G14*F500JNONNNNN ⁽⁴⁾	
650	715	630	590	649	885	560	460	690	828	450	21G14*F590JNONNNNN ⁽⁴⁾	9 ⁽⁵⁾
710	781	710	650	715	975	630	500	750	900	500	21G14*F650JNONNNNN ⁽⁴⁾	
790	869	800	710	781	1065	710	590	885	1062	560	21G14*F710JNONNNNN ⁽⁴⁾	
860	946	850	765	842	1148	750	650	975	1170	630	21G14*F765JNONNNNN ⁽⁴⁾	
960	1056	900	795	875	1193	800	750	1125	1350	710	21G14*F795JNONNNNN ⁽⁴⁾	
1020	1122	1000	960	1056	1440	900	795	1193	1431	800	21G14*F960JNONNNNN ⁽⁴⁾	10 ⁽⁵⁾
1150	1265	1100	1040	1144	1560	1000	865	1298	1557	900	21G14*F1K0JNONNNNN ⁽⁴⁾	
1485	1634	1500	1400	1540	2100	1400	1160	1740	2088	1120	21G14*F1K4JNONNNNN ⁽⁴⁾	

(1) Frames 6...7 are IP00, NEMA/UL Type Open. Frames 8...10 are IP20, NEMA/UL Type 1. Frames 6...7 can be converted to IP20, NEMA/UL Type 1 with optional kit (20-750-NEMA1-Fx), where x is the frame size of the drive.

(2) Light Duty rating only available on Frame 8...10 drives. Light Duty allows 110% overload for 1 minute, and does not have a 3 second overload rating.

(3) The 12th character determines whether an internal dynamic braking IGBT is included; "A" = Internal dynamic braking transistor installed, and "N" = No internal dynamic braking transistor.

(4) The 6th character (designated by an * in this table) determines the enclosure type. Refer to the Enclosure Type table in the [Catalog Number Explanation on page 5](#).

(5) A roll-out cart is required with Frame 8...10 drives to assist with power wiring and cabinet mounting. See page [199](#).

932V DC Nominal Input - Common Bus Drives (continued)

IP54, NEMA/UL Type 12

Light Duty ⁽¹⁾			Normal Duty				Heavy Duty				Cat. No.	Frame Size
Output Amps		kW	Output Amps			kW	Output Amps			kW		
Cont.	60 s		Cont.	60 s	3 s		Cont.	60 s	3 s			
-	-	-	12	13.2	18	7.5	9	13.5	18	5.5	20G14GF012JNONNNNN ⁽²⁾	6
			15	16.5	22.5	11	12	18	22.5	7.5	20G14GF015JNONNNNN ⁽²⁾	
			20	22	30	15	15	22.5	30	11	20G14GF020JNONNNNN ⁽²⁾	
			23	25.3	34.5	18.5	20	30	36	15	20G14GF023JNONNNNN ⁽²⁾	
			30	33	45	22	23	34.5	45	18.5	20G14GF030JNONNNNN ⁽²⁾	
			34	37.4	51	30	30	45	54	22	20G14GF034JNONNNNN ⁽²⁾	
			46	50.6	69	37	34	51	69	30	20G14GF046JNONNNNN ⁽²⁾	
			50	55	75	45	46	69	83	37	20G14GF050JNONNNNN ⁽²⁾	
			61	67	92	55	50	75	92	45	20G14GF061JNONNNNN ⁽²⁾	
			82	90	123	75	61	92	123	55	20G14GF082JNONNNNN ⁽²⁾	
			98	108	147	90	82	123	148	75	20G14GF098JNONNNNN ⁽²⁾	
			119	131	179	110	98	147	179	90	20G14GF119JNONNNNN ⁽²⁾	
			142	156	213	132	119	179	214	110	20G14GF142JNONNNNN ⁽²⁾	
			171	188	257	160	142	213	257	132	20G14GF171JNONNNNN ⁽²⁾	
			212	233	318	200	171	257	318	160	20G14GF212JNONNNNN ⁽²⁾	7
			263	289	395	250	212	318	395	200	20G14GF263JNONNNNN ⁽²⁾	
330	363	315	265	292	398	250	215	323	387	200	21G14*F265JNONNNNN ⁽³⁾	8 ⁽⁴⁾
370	407	355	330	363	495	315	265	398	477	250	21G14*F330JNONNNNN ⁽³⁾	
410	451	400	370	407	555	355	308	462	554	300	21G14*F370JNONNNNN ⁽³⁾	
460	506	450	415	457	623	400	370	555	666	355	21G14*F415JNONNNNN ⁽³⁾	
500	550	500	460	506	690	450	375	563	675	375	21G14*F460JNONNNNN ⁽³⁾	
530	583	530	500	550	750	500	413	620	743	400	21G14*F500JNONNNNN ⁽³⁾	
650	715	630	590	649	885	560	460	690	828	450	21G14*F590JNONNNNN ⁽³⁾	
710	781	710	650	715	975	630	500	750	900	500	21G14*F650JNONNNNN ⁽³⁾	9 ⁽⁴⁾
790	869	800	710	781	1065	710	590	885	1062	560	21G14*F710JNONNNNN ⁽³⁾	
860	946	850	765	842	1148	750	650	975	1170	630	21G14*F765JNONNNNN ⁽³⁾	
960	1056	900	795	875	1193	800	750	1125	1350	710	21G14*F795JNONNNNN ⁽³⁾	
1020	1122	1000	960	1056	1440	900	795	1193	1431	800	21G14*F960JNONNNNN ⁽³⁾	10 ⁽⁴⁾
1150	1265	1100	1040	1144	1560	1000	865	1298	1557	900	21G14*F1K0JNONNNNN ⁽³⁾	
1485	1634	1500	1400	1540	2100	1400	1160	1740	2088	1120	21G14*F1K4JNONNNNN ⁽³⁾	

(1) Light Duty rating only available on Frame 8...10 drives. Light Duty allows 110% overload for 1 minute, and does not have a 3 second overload rating.
 (2) The 12th character determines whether an internal dynamic braking IGBT is included; "A" = internal dynamic braking transistor installed, and "N" = No internal dynamic braking transistor.
 (3) The 6th character (designated by an * in this table) determines the enclosure type. Refer to the Enclosure Type table in the [Catalog Number Explanation on page 5](#).
 (4) A roll-out cart is required with Frame 8...10 drives to assist with power wiring and cabinet mounting. See page [199](#).

Flange Mount (Front: IP20, NEMA/UL Type Open; Back/Heatsink: IP66, NEMA/UL Type 4X)

Tip: Frame 6...7 IP00, NEMA Type Open drives can be converted to a flange mount drive (Back/Heatsink: IP66, NEMA/UL Type 4X) with an optional user installed flange kit (20-750-FLNG4-F6 for Frame 6, and 20-750-FLNG4-F7 for Frame 7). See page [49](#) for 932V DC, Frame 6...7 IP00, NEMA Type Open drives.

PowerFlex 755 Floor Mount Drives for Open Frame Designs

Floor mount, open frame drives are for applications that require power ranges from 215 kW to 1500kW (250 Hp...2000 Hp) and are contained within an enclosure of your choosing. These drives use the same drive unit(s) as standard IP20 and IP54 product. Open Frame applications can accommodate either AC input or Common Bus DC input systems.

Floor mount, open frame drives can also be horizontally mounted, with derating. See publication [750-INO20](#) for details.

To order an IPO0 drive:

- Using the tables that follow, locate your desired drive output values.
- Select the Base Drive Catalog Number for your desired output values.
- Note the Quantity Required.
- Order the specified quantity (1, 2, or 3) of the Base Drive Catalog Number.
- See page 130 for option kits and the PowerFlex 755 IPO0 NEMA/UL Open Type Drive Installation Instructions, publication [750-INO20](#) for installation details.

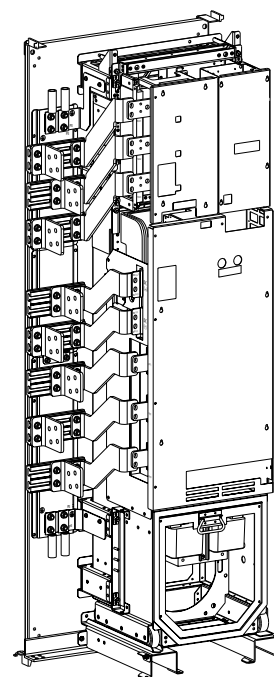

380...400V AC, Three-phase and 540V DC Drives with DC Inputs

Light Duty		Normal Duty		Heavy Duty		Base Drive Cat. No.	Quantity Required	Equivalent Frame Size ⁽¹⁾
Output Amps	kW	Output Amps	kW	Output Amps	kW			
Cont.		Cont.		Cont.				
540	315	460	250	385	200	20G11TC460JNONNNNN	1	8
585	315	540	315	456	250	20G11TC540JNONNNNN		
612	355	567	315	472	250	20G11TC567JNONNNNN		
750	400	650	355	540	315	20G11TC650JNONNNNN		
796	450	750	400	585	315	20G11TC750JNONNNNN		
832	450	770	400	642	355	20G11TC770JNONNNNN		
1040	560	910	500	750	400	20G11TC460JNONNNNN	2	9
1090	630	1040	560	880	500	20G11TC540JNONNNNN		
1175	710	1090	630	910	500	20G11TC567JNONNNNN		
1465	800	1175	710	1040	560	20G11TC650JNONNNNN		
1480	850	1465	800	1090	630	20G11TC750JNONNNNN		
1600	900	1480	850	1175	710	20G11TC770JNONNNNN		
1715	1000	1590	900	1325	710	20G11TC567JNONNNNN	3	10
2330	1400	2150	1250	1800	1000	20G11TC770JNONNNNN		

(1) A roll-out cart is required with Frame 8...10 drives to assist with power wiring and cabinet mounting. See page [200](#).

540V DC Nominal Input - Common Bus Drives

Light Duty (-LD)		Normal Duty (-ND)		Heavy Duty (-HD)		Base Drive Cat. No. ⁽¹⁾	Quantity Required	Equivalent Frame Size ⁽²⁾
Output Amps	kW	Output Amps	kW	Output Amps	kW			
Cont.		Cont.		Cont.				
540	315	460	250	385	200	20G14TC460JNONNNNN	1	8
585	315	540	315	456	250	20G14TC540JNONNNNN		
612	355	567	315	472	250	20G14TC567JNONNNNN		
750	400	650	355	540	315	20G14TC650JNONNNNN		
796	450	750	400	585	315	20G14TC750JNONNNNN		
832	450	770	400	642	355	20G14TC770JNONNNNN		
1040	560	910	500	750	400	20G14TC460JNONNNNN	2	9
1090	630	1040	560	880	500	20G14TC540JNONNNNN		
1175	710	1090	630	910	500	20G14TC567JNONNNNN		
1465	800	1175	710	1040	560	20G14TC650JNONNNNN		
1480	850	1465	800	1090	630	20G14TC750JNONNNNN		
1600	900	1480	850	1175	710	20G14TC770JNONNNNN		
1715	1000	1590	900	1325	710	20G14TC567JNONNNNN	3	10
2330	1400	2150	1250	1800	1000	20G14TC770JNONNNNN		

(1) The 11th character determines default filtering and common mode cap jumper configuration. "J" = Installed, "A" = Removed.
 (2) A roll-out cart is required with Frame 8...10 drives to assist with power wiring and cabinet mounting. See page 199.

480V AC, Three-phase and 650V DC Drives with DC Inputs

Light Duty		Normal Duty		Heavy Duty		Base Drive Cat. No.	Quantity Required	Equivalent Frame Size ⁽¹⁾
Output Amps	Hp	Output Amps	Hp	Output Amps	Hp			
Cont.		Cont.		Cont.				
485	400	430	350	370	300	20G11TD430JNONNNNN	1	8
545	450	485	400	414	350	20G11TD485JNONNNNN		
590	500	545	450	454	350	20G11TD545JNONNNNN		
710	600	617	500	485	400	20G11TD617JNONNNNN		
765	650	710	600	545	450	20G11TD710JNONNNNN		
800	700	740	650	617	500	20G11TD740JNONNNNN		
960	800	800	700	710	600	20G11TD430JNONNNNN	2	9
1045	900	960	800	795	700	20G11TD485JNONNNNN		
1135	1000	1045	900	800	750	20G11TD545JNONNNNN		
1365	1100	1135	1000	960	800	20G11TD617JNONNNNN		
1420	1250	1365	1100	1045	900	20G11TD710JNONNNNN		
1540	1350	1420	1250	1135	1000	20G11TD740JNONNNNN		
1655	1500	1525	1350	1270	1100	20G11TD545JNONNNNN	3	10
2240	2000	2070	1750	1730	1650	20G11TD740JNONNNNN		

(1) A roll-out cart is required with Frame 8...10 drives to assist with power wiring and cabinet mounting. See page 200.

650V DC Nominal Input - Common Bus Drives

Light Duty (-LD)		Normal Duty (-ND)		Heavy Duty (-HD)		Base Drive Cat. No.	Quantity Required	Equivalent Frame Size ⁽¹⁾
Output Amps	Hp	Output Amps	Hp	Output Amps	Hp			
Cont.		Cont.		Cont.				
485	400	430	350	370	300	20G14TD430JNONNNNN	1	8
545	450	485	400	414	350	20G14TD485JNONNNNN		
590	500	545	450	454	350	20G14TD545JNONNNNN		
710	600	617	500	485	400	20G14TD617JNONNNNN		
765	650	710	600	545	450	20G14TD710JNONNNNN		
800	700	740	650	617	500	20G14TD740JNONNNNN		
960	800	800	700	710	600	20G14TD430JNONNNNN	2	9
1045	900	960	800	795	700	20G14TD485JNONNNNN		
1135	1000	1045	900	800	750	20G14TD545JNONNNNN		
1365	1100	1135	1000	960	800	20G14TD617JNONNNNN		
1420	1250	1365	1100	1045	900	20G14TD710JNONNNNN		
1540	1350	1420	1250	1135	1000	20G14TD740JNONNNNN		
1655	1500	1525	1350	1270	1100	20G14TD545JNONNNNN	3	10
2240	2000	2070	1750	1730	1650	20G14TD740JNONNNNN		

(1) A roll-out cart is required with Frame 8...10 drives to assist with power wiring and cabinet mounting. See page [200](#).

600V AC, Three-phase and 810V DC Drives with DC Inputs

Light Duty		Normal Duty		Heavy Duty		Base Drive Cat. No.	Quantity Required	Equivalent Frame Size ⁽¹⁾
Output Amps	Hp	Output Amps	Hp	Output Amps	Hp			
Cont.		Cont.		Cont.				
355	350	295	300	272	250	20G11TE295JNONNNNN	1	8
395	400	355	350	295	300	20G11TE355JNONNNNN		
435	450	395	400	329	350	20G11TE395JNONNNNN		
460	500	435	450	355	350	20G11TE435JNONNNNN		
510	500	460	500	395	400	20G11TE460JNONNNNN		
545	550	510	500	425	450	20G11TE510JNONNNNN		
690	700	595	600	510	500	20G11TE295JNONNNNN	2	9
760	800	630	700	595	600	20G11TE355JNONNNNN		
835	900	760	800	630	700	20G11TE395JNONNNNN		
900	950	825	900	700	750	20G11TE435JNONNNNN		
980	1000	900	950	760	800	20G11TE460JNONNNNN		
1045	1100	980	1000	815	900	20G11TE510JNONNNNN		
1220	1200	1110	1100	920	1000	20G11TE395JNONNNNN	3	10
1530	1500	1430	1400	1190	1250	20G11TE510JNONNNNN		

(1) A roll-out cart is required with Frame 8...10 drives to assist with power wiring and cabinet mounting. See page [200](#).

810V DC Nominal Input - Common Bus Drives

Light Duty (-LD)		Normal Duty (-ND)		Heavy Duty (-HD)		Base Drive Cat. No.	Quantity Required	Equivalent Frame Size ⁽¹⁾
Output Amps	Hp	Output Amps	Hp	Output Amps	Hp			
Cont.		Cont.		Cont.				
355	350	295	300	272	250	20G14TE295JNONNNNN	1	8
395	400	355	350	295	300	20G14TE355JNONNNNN		
435	450	395	400	329	350	20G14TE395JNONNNNN		
460	500	435	450	355	350	20G14TE435JNONNNNN		
510	500	460	500	395	400	20G14TE460JNONNNNN		
545	550	510	500	425	450	20G14TE510JNONNNNN		
690	700	595	600	510	500	20G14TE295JNONNNNN	2	9
760	800	630	700	595	600	20G14TE355JNONNNNN		
835	900	760	800	630	700	20G14TE395JNONNNNN		
900	950	825	900	700	750	20G14TE435JNONNNNN		
980	1000	900	950	760	800	20G14TE460JNONNNNN		
1045	1100	980	1000	815	900	20G14TE510JNONNNNN		
1220	1200	1110	1100	920	1000	20G14TE395JNONNNNN	3	10
1530	1500	1430	1400	1190	1250	20G14TE510JNONNNNN		

(1) A roll-out cart is required with Frame 8...10 drives to assist with power wiring and cabinet mounting. See page 200.

690V AC, Three-phase and 932V DC Drives with DC Inputs

Light Duty (-LD)		Normal Duty (-ND)		Heavy Duty (-HD)		Base Drive Cat. No.	Quantity Required	Equivalent Frame Size ⁽¹⁾
Output Amps	kW	Output Amps	kW	Output Amps	kW			
Cont.		Cont.		Cont.				
330	315	265	250	215	200	20G11TF265JNONNNNN	1	8
370	355	330	315	265	250	20G11TF330JNONNNNN		
410	400	370	355	308	300	20G11TF370JNONNNNN		
460	450	415	400	370	355	20G11TF415JNONNNNN		
500	500	460	450	375	375	20G11TF460JNONNNNN		
530	530	500	500	413	400	20G11TF500JNONNNNN		
650	630	590	560	460	450	20G11TF265JNONNNNN	2	9
710	710	650	630	500	500	20G11TF330JNONNNNN		
790	800	710	710	590	560	20G11TF370JNONNNNN		
860	850	765	750	650	630	20G11TF415JNONNNNN		
960	900	795	800	750	710	20G11TF460JNONNNNN		
1020	1000	960	900	795	800	20G11TF500JNONNNNN		
1150	1100	1040	1000	865	900	20G11TF370JNONNNNN	3	10
1485	1500	1400	1400	1160	1120	20G11TF500JNONNNNN		

(1) A roll-out cart is required with Frame 8...10 drives to assist with power wiring and cabinet mounting. See page 200.

932V DC Nominal Input - Common Bus Drives

Light Duty (-LD)		Normal Duty (-ND)		Heavy Duty (-HD)		Base Drive Cat. No. (1)	Quantity Required	Equivalent Frame Size (2)
Output Amps	kW	Output Amps	kW	Output Amps	kW			
Cont.		Cont.		Cont.				
330	315	265	250	215	200	20G14TF265JNONNNNN	1	8
370	355	330	315	265	250	20G14TF330JNONNNNN		
410	400	370	355	308	300	20G14TF370JNONNNNN		
460	450	415	400	370	355	20G14TF415JNONNNNN		
500	500	460	450	375	375	20G14TF460JNONNNNN		
530	530	500	500	413	400	20G14TF500JNONNNNN		
650	630	590	560	460	450	20G14TF265JNONNNNN	2	9
710	710	650	630	500	500	20G14TF330JNONNNNN		
790	800	710	710	590	560	20G14TF370JNONNNNN		
860	850	765	750	650	630	20G14TF415JNONNNNN		
960	900	795	800	750	710	20G14TF460JNONNNNN		
1020	1000	960	900	795	800	20G14TF500JNONNNNN		
1150	1100	1040	1000	865	900	20G14TF370JNONNNNN	3	10
1485	1500	1400	1400	1160	1120	20G14TF500JNONNNNN		

(1) The 11th character determines filtering and common mode cap jumper configuration. "J" = Installed, "A" = Removed.

(2) A roll-out cart is required with Frame 8...10 drives to assist with power wiring and cabinet mounting. See page 200.

Option kits provide electrical connections, mounting and ventilation provisions along with the control pod and its corresponding cables for PowerFlex 755 Floor Mount Open Frame designs. Other available accessories include the rollout cart and EMC cores. See PowerFlex 755 IP00, NEMA/UL Open Type Drive Frames 8...10, publication [750-IN020](#) for option kit details.

Power Options for PowerFlex 755 Floor Mount, AC Input Drives

Pre-engineered, factory installed options are available with the PowerFlex 755 floor mount drives, which includes disconnects, reactors, contactors, MCC bus and wiring only bays.

To configure a catalog number for a floor-mount drive with options, perform the following steps:

1. Select the base drive catalog number from the tables on pages 108...111. Drive selection is based on the output amps and corresponding system overload(s) required by the application.
2. Select the duty rating. See the Required Options table on page 107 for duty rating details. For example: 21G1ALC460JNONNNNN-**LD**.
3. Select the desired enclosure type as described on pages 108...111. For example: 21G1ALC460JNONNNNN-LD.
4. Select Power Disconnect and/or Wire Only Bay option from the Required Options table on page 107. Add the desired option codes to the end of the base drive catalog number, separating each option code with a dash. For example: 21G1ALC460JNONNNNN-LD-**P3**.
5. If options listed in the Additional Options table on page 107 are required, add the option code(s) to the end of the drive catalog number, separating each code with a dash. For example: 21G1ALC460JNONNNNN-LD-P3-**P11**.

Note: A 600 mm wide cabinet bay is added to the right of the drive cabinet(s) to house the power options. The Wiring Only Bay option (-P14) also adds a 600 mm wide cabinet bay to the right of the drive cabinet(s).

Frame 8 with Power Option Bay

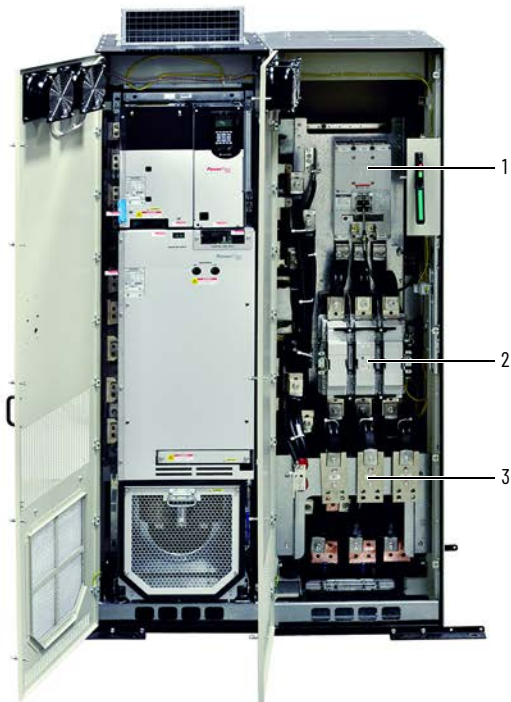

Input power landed on line-side of power disconnect.

Frame 9 with Power Option Bay



Input power landed behind circuit breaker, which is accessed by extracting rollout

Item	Description
1	Power Disconnect: Options -P3 or -P5
2	Contactors: Options -P11 or -P12
3	Reactor: Options -L1, -L2, -L3, or -L4

See Additional Options on page 56.

Required Options

Type	Option	Frame Size	Description
System Overload Duty Cycle ⁽¹⁾⁽²⁾	LD	Light Duty	100% continuous current, 110% current for 1 minute.
	ND	Normal Duty	100% continuous current, 110% current for 1 minute, 150% for 3 seconds.
	HD	Heavy Duty	100% continuous current, 150% current for 1 minute, 180% for 3 seconds.
Power Disconnect ⁽¹⁾	P3	Input Thermal Magnetic Circuit Breaker	8...10 ⁽³⁾ This option is for disconnecting drive power. An Allen-Bradley 140G Molded Case Circuit Breaker is provided. Frame 8 drives include flange style handle operators that are door interlocking and padlockable. Frame 9 drive circuit breakers are pushbutton actuated with door interlocks and are padlockable.
	P5	Input Non-Fused Molded Case Disconnect Switch	8 Only This option is for disconnecting drive power. An Allen-Bradley 140G Molded Case Switch is provided. All switches include flange style handle operators that are door interlocking and padlockable. Note: PowerFlex 755 Frame 8 converter modules input fuses installed as standard equipment do not provide branch protection.
Wiring Only Bay	P14	Wiring Only Bay	8...10 This option identifies that an extra bay is provided for wiring the drive. This option extends the drive power bus from the drive bay into the option bay, making field connection options more flexible. No drive input protection is supplied with this option selection. If desired, a power option bay with a disconnect option can be added to the wiring bay. Documentation to reflect input disconnection and protection is customer supplied. See page 130 for more information on power cable entry/exit locations.

(1) Only one option of this type can be selected.
 (2) See following selection tables for specific rating information.
 (3) Frame 10 ordered via Engineered-To-Order (ETO) process.

Additional Options

Type	Option		Applicable Frame Size	Description
Contactors ⁽¹⁾⁽²⁾	P11	Input Contactor	8 Only	A contactor is provided between the AC line and the drive. The contactor is controlled by customer supplied 120V AC (480V input) or 230V AC (400V input) remote contact closure logic. A terminal block for control is provided for customer use, and is wired to 1 N.O. and 1 N.C. auxiliary contact on the contactor. IMPORTANT The P11 option 'Alternate Contact Circuit' is not intended to be used as a Start/Stop circuit.
	P12	Output Contactor		A contactor is provided between the drive output and the motor. The contactor is controlled by customer supplied 120V AC (480V input) or 230V AC (400V input) remote contact closure logic. A terminal block for control is provided for customer use and is wired to 1 N.O. and 1 N.C. auxiliary contact on the contactor. Note: As an alternative to an output contactor, certain safety applications can be satisfied using the PowerFlex 750-Series Safe Torque Off Option Card (Cat. No. 20-750-S). Safe Torque Off is ideal for safety related applications requiring removal of rotational power to the motor without removing power from the drive. Safe Torque Off functionality offers the benefit of quick start-up after a demand on the safety system and helps reduce wear from repetitive start-up. It also provides safety ratings up to and including SIL3, PLe, and CAT 3.
Reactors ⁽¹⁾⁽³⁾	L1	3% Input Reactor	8...9	Provides an open core drive input line reactor that mounts inside the power bay option enclosure. Typical impedance is 3%.
	L2	3% Output Reactor		Provides an open core drive output load reactor, which mounts inside the power bay option enclosure. Typical impedance is 3%.
	L3	5% Input Reactor	8 Only	Provides an open core drive input line reactor that mounts inside the power bay option enclosure. Typical impedance is 5%.
	L4	5% Output Reactor		Provides an open core drive output load reactor, which mounts inside the power bay option enclosure. Typical impedance is 5%.
MCC Power Bus ⁽¹⁾⁽⁴⁾	P20	1250 Amp Bus	8...10	Provides a 1250 Amp MCC Bus.
	P22	2000 Amp Bus		Provides a 2000 Amp MCC Bus.
	P24	3000 Amp Bus		Provides a 3000 Amp MCC Bus.
Auxiliary Power	X1	Auxiliary Transformer	8 Only	Auxiliary transformer providing 500VA. Available as an option on frame 8, IP20 units. This option is standard on all other cabinet configurations.

(1) Only one option of this type can be selected.

(2) Contactor options are not available for systems with MCC power bus.

(3) To accommodate a larger reactor, an 800 mm deep cabinet must be selected for the following Frame 8 drives; C750, C770, D710, D740 at light duty (LD), and C770 at normal-duty (ND).

(4) MCC bus is connected to the line side of the disconnect, as delivered from the factory.

Enclosure Type Selections

Code	Description
B	600 mm deep, IP20/NEMA 1, standard color (RAL 7032)
L	800 mm deep, IP20/NEMA 1, standard color (RAL 7032)
P	800 mm deep, IP20/NEMA 1, with Motor Control Center (MCC) power bus option, standard color (RAL 7032)
W	800 mm deep, IP20/NEMA 1, with MCC power bus option, CENTERLINE 2100 gray (ASA49)
J	800 mm deep, IP54/NEMA 12, standard color (RAL 7032)
K	800 mm deep, IP54/NEMA 12, with MCC power bus option, standard color (RAL 7032)
Y	800 mm deep, IP54/NEMA 12, with MCC power bus option, CENTERLINE 2100 gray (ASA49)

380...400V AC, Three-phase Input Drives ^{(1) (2)}

Light Duty			Normal Duty				Heavy Duty				Base Drive Cat. No. ^{(3) (4)}	Frame Size	
Output Amps			Hp	Output Amps			Hp	Output Amps					Hp
Cont.	60 s	3 s		Cont.	60 s	3 s		Cont.	60 s	3 s			
485	534	-	400	430	473	666	350	370	555	666	300	21G1A*D430JNONNNNN	8
545	600		450	485	534	745	400	414	621	745	350	21G1A*D485JNONNNNN	
590	649		500	545	600	818	450	454	681	818	350	21G1A*D545JNONNNNN	
710	781		600	617	679	926	500	485	728	926	400	21G1A*D617JNONNNNN	
765	842		650	710	781	1065	600	545	818	1065	450	21G1A*D710JNONNNNN	
800	880		700	740	817	1110	650	617	926	1110	500	21G1A*D740JNONNNNN	
960	1056		800	800	880	1278	700	710	1065	1278	600	21G11*D800JNONNNNN	9
1045	1150		900	960	1056	1440	800	795	1193	1440	700	21G11*D960JNONNNNN	
1135	1249		1000	1045	1150	1568	900	800	1200	1568	750	21G11*D1K0JNONNNNN	
1365	1502		1100	1135	1249	1728	1000	960	1440	1728	800	21G11*D1K2JNONNNNN	
1420	1562	1250	1365	1502	2048	1100	1045	1568	2048	900	21G11*D1K3JNONNNNN		
1540	1694	1350	1420	1562	2130	1250	1135	1703	2130	1000	21G11*D1K4JNONNNNN		
1655	1821	1500	1525	1678	2288	1350	1270	1905	2288	1100	21G11*D1K5JNONNNNN	10	
2240	2464	2000	2070	2277	3105	1750	1730	2595	3105	1650	21G11*D2K0JNONNNNN		

- (1) Contact your local Rockwell Automation sales office or Allen-Bradley distributor for availability.
- (2) A Roll-out Cart is required with Frame 8...10 drives to assist with power wiring and cabinet mounting. See page 200.
- (3) The 5th character determines Input Type. "T" = AC input with precharge and DC terminals. "A" = AC input with precharge and no DC terminals. For DC input drives, see DRIVES-SG001, the PowerFlex Common Bus Configuration Selection Guide.
- (4) The 6th character (designated by an * in this table) determines enclosure type. For that selection, refer to the Enclosure Type Selections table on this page.

600V AC, Three-phase Input Drives ^{(1) (2)}

Light Duty			Normal Duty				Heavy Duty				Base Drive Cat. No. ^{(3) (4)}	Frame Size	
Output Amps			Hp	Output Amps			Hp	Output Amps					Hp
Cont.	60 s	3 s		Cont.	60 s	3 s		Cont.	60 s	3 s			
355	391	-	350	295	325	490	300	272	408	490	250	21G1A*E295JNONNNNN	8
395	435		400	355	391	533	350	295	443	533	300	21G1A*E355JNONNNNN	
435	479		450	395	435	593	400	329	494	593	350	21G1A*E395JNONNNNN	
460	506		500	435	479	639	450	355	533	639	350	21G1A*E435JNONNNNN	
510	561		500	460	506	711	500	395	593	711	400	21G1A*E460JNONNNNN	
545	600		550	510	561	765	500	425	638	765	450	21G1A*E510JNONNNNN	
690	759		700	595	655	918	600	510	765	918	500	21G11*E595JNONNNNN	9
760	836		800	630	693	1071	700	595	893	1071	600	21G11*E630JNONNNNN	
835	919		900	760	836	1140	800	630	945	1140	700	21G11*E760JNONNNNN	
900	990		950	825	908	1260	900	700	1050	1260	750	21G11*E825JNONNNNN	
980	1078	1000	900	990	1368	950	760	1140	1368	800	21G11*E900JNONNNNN		
1045	1150	1100	980	1078	1470	1000	815	1223	1470	900	21G11*E980JNONNNNN		
1220	1342	1200	1110	1221	1665	1100	920	1380	1665	1000	21G11*E1K1JNONNNNN	10	
1530	1683	1500	1430	1573	2145	1400	1190	1785	2145	1250	21G11*E1K4JNONNNNN		

- (1) Contact your local Rockwell Automation sales office or Allen-Bradley distributor for availability.
- (2) A Roll-out Cart is required with Frame 8...10 drives to assist with power wiring and cabinet mounting. See page 200.
- (3) The 5th character determines Input Type. "T" = AC input with precharge and DC terminals. "A" = AC input with precharge and no DC terminals. For DC input drives, see DRIVES-SG001, the PowerFlex Common Bus Configuration Selection Guide.
- (4) The 6th character (designated by an * in this table) determines enclosure type. For that selection, refer to the Enclosure Type Selections table on this page.

690V AC, Three-phase Input Drives ^{(1) (2)}

Light Duty			Normal Duty				Heavy Duty				Base Drive Cat. No. ^{(3) (4)}	Frame Size	
Output Amps			Hp	Output Amps			Hp	Output Amps					Hp
Cont.	60 s	3 s		Cont.	60 s	3 s		Cont.	60 s	3 s			
330	363	-	315	265	292	375	250	215	323	375	200	21G1A*F265JNONNNNN	8
370	407		355	330	363	473	315	265	398	473	250	21G1A*F330JNONNNNN	
410	451		400	370	407	555	355	308	462	555	300	21G1A*F370JNONNNNN	
460	506		450	415	457	639	400	370	555	639	355	21G1A*F415JNONNNNN	
500	550		500	460	506	675	450	375	563	675	375	21G1A*F460JNONNNNN	
530	583		530	500	550	750	500	413	620	750	400	21G1A*F500JNONNNNN	
650	715		630	590	649	885	560	460	690	885	450	21G11*F590JNONNNNN	9
710	781		710	650	715	975	630	500	750	975	500	21G11*F650JNONNNNN	
790	869		800	710	781	1065	710	590	885	1065	560	21G11*F710JNONNNNN	
860	946		850	765	842	1170	750	650	975	1170	630	21G11*F765JNONNNNN	
960	1056		900	795	875	1350	800	750	1125	1350	710	21G11*F795JNONNNNN	
1020	1122		1000	960	1056	1440	900	795	1193	1440	800	21G11*F960JNONNNNN	
1150	1265		1100	1040	1144	1560	1000	865	1298	1560	900	21G11*F1K0JNONNNNN	10
1485	1634		1500	1400	1540	2100	1400	1160	1740	2100	1120	21G11*F1K4JNONNNNN	

(1) Contact your local Rockwell Automation sales office or Allen-Bradley distributor for availability.

(2) A Roll-out Cart is required with Frame 8...10 drives to assist with power wiring and cabinet mounting. See page 200.

(3) The 5th character determines Input Type. "T" = AC input with precharge and DC terminals. "A" = AC input with precharge and no DC terminals. For DC input drives, see DRIVES-SG001, the PowerFlex Common Bus Configuration Selection Guide.

(4) The 6th character (designated by an * in this table) determines enclosure type. For that selection, refer to the Enclosure Type Selections table on this page.

Connect to a CENTERLINE 2100 Motor Control Center (MCC)

Select the splice kit best suited for your application, determine which drive side that you want to connect.

NOTE: A splice kit contains three splice plates.

PowerFlex 755 CENTERLINE 2100 Splice Kits

A complete installation requires one transition section and one bus bar splicing kit. Splicing kits include all necessary hardware to complete connection of all three-phases.

PowerFlex 755 CENTERLINE® 2100 Splice Kits

Mounting Channel	Busbar Position ⁽¹⁾	Amp Rating	Left-side Kit Cat. No.	Right-side Kit Cat. No.	Frame Sizes
N/A	Transition section ⁽²⁾	N/A	20-750-XSEC-LH-20G	20-750-XSEC-RH-20G	8...10
For use with MCCs that have 1.5 in. mounting channels	Standard	1200	20-750-XBUS-LHNB-1200	20-750-XBUS-RHNB-1200	
		2000	20-750-XBUS-LHNB-2000	20-750-XBUS-RHNB-2000	
		3000	20-750-XBUS-LHNB-3000	20-750-XBUS-RHNB-3000	
	Bumped back	1200	20-750-XBUS-LHBB-1200	20-750-XBUS-RHBB-1200	
		2000	20-750-XBUS-LHBB-2000	20-750-XBUS-RHBB-2000	
		3000	20-750-XBUS-LHBB-3000	20-750-XBUS-RHBB-3000	
For use with MCCs that do not have mounting channels	Standard	1200	20-750-XBUS-LLNB-1200	20-750-XBUS-RLNB-1200	8...10
		2000	20-750-XBUS-LLNB-2000	20-750-XBUS-RLNB-2000	
		3000	20-750-XBUS-LLNB-3000	20-750-XBUS-RLNB-3000	
	Bumped back	1200	20-750-XBUS-LLBB-1200	20-750-XBUS-RLBB-1200	
		2000	20-750-XBUS-LLBB-2000	20-750-XBUS-RLBB-2000	
		3000	20-750-XBUS-LLBB-3000	20-750-XBUS-RLBB-3000	

(1) All busbar positions are 20 in. deep.

(2) Hardware is included to install the optional 1.5 in. mounting channel.

PowerFlex 755 Empty Option Bay

This section is for applications with a PowerFlex 755 floor mount drive that need additional cabinet space. These added cabinets provide an elegant packaging option when expanding a PowerFlex 755, frame 8, 9, or 10 lineup. All Empty Option Bay cabinets match the standard color (RAL 7032) of the PowerFlex 755 Floor Mount Drive. Each Empty Option Bay includes a sub-panel. Reference publication For installation details, see publication 750-IN031.

The Right Mount Bus Bar kits listed below can only be installed to the right of a PowerFlex 755 Floor Mount Drive, when facing the front of the drive. If the application requires mounting the Empty Option Bay to the left of the PowerFlex 755 Floor Mount Drive, then the Rear Drive Bus Bar can be installed behind the drive unit(s). Power cabling is landed on the Rear Drive Bus Bars and passed through the cabinet side wall to the Empty Option Bay.

The Option Bay Hardware Kit listed below contains the door handle, an air barrier (for use between cabinets) and a door overlay label. One is required for each option bay.

PowerFlex 755 Empty Option Bay ⁽¹⁾

Description	Cat. No.	Frame Sizes
Option Bay, 600 mm wide by 600 mm deep, Beige ⁽²⁾	20-750-PBAY-66 8...10	8...10
Option Bay, 800 mm wide by 600 mm deep, Beige ⁽²⁾	20-750-PBAY-86	
Option Bay, 1200 mm wide by 600 mm deep, Beige ⁽²⁾	20-750-PBAY-126	
Option Bay, 600 mm wide by 800 mm deep, Beige ⁽³⁾	20-750-PBAY-68	
Option Bay, 800 mm wide by 800 mm deep, Beige ⁽³⁾	20-750-PBAY-88	
Option Bay, 1200 mm wide by 800 mm deep, Beige ⁽³⁾	20-750-PBAY-128	
Option Bay Hardware Kit (one kit is required for each cabinet selected) ⁽⁴⁾	20-750-PBAY-HWD-1	
Option Bay Seal Kit, IP54	20-750-PBAY-IP54	
Empty Bay, RH Bus Bar, 975 A, continuous ⁽⁵⁾	20-750-PBAY-RHBB-975	
Empty Bay, RH Bus Bar, 1235 A, continuous ⁽⁵⁾	20-750-PBAY-RHBB-1235	
Empty Bay, RH Bus Bar, 1625 A, continuous ⁽⁵⁾	20-750-PBAY-RHBB-1625	
Empty Bay, RH Bus Bar, 2437 A, continuous ⁽⁵⁾	20-750-PBAY-RHBB-2437	
Right Mount Bus Bar, Cable Connection, 2-Hole	20-750-PBAY-LBRK-2	
Right Mount Bus Bar, Cable Connection, 4-Hole	20-750-PBAY-LBRK-4	
Right Mount Bus Bar, Installation Kit, 3-Phase Connection ⁽⁵⁾	20-750-PBAY-INS-3	
Right Mount Bus Bar, Installation Kit, DC Connection ⁽⁵⁾	20-750-PBAY-INS-2	
Rear Drive Bus Bar, Cable Connection ⁽³⁾	20-750-PBAY-RBRK-2	

(1) Contact your local Rockwell Automation sales office or Allen-Bradley distributor for availability.

(2) Only use with 600mm deep cabinet (drive enclosure code B).

(3) Only use with a 800 mm deep cabinet (drive enclosure code J, K, L, P, W or Y).

(4) Hardware kit includes door handle, door overlay label and Formex air barrier (installed between cabinets).

(5) Installed to the right of any PowerFlex 755 floor mount drive except a Frame 8 with disconnect (-P3 or -P5 option).

Certifications and Specifications

This section provides information for certifications and specifications.

Certifications

Certification	Description
ABS	American Bureau of Shipping Certificate 11-HS743429
c-UL-us	Listed to UL508C and CSA22.2 No. 14 (does not apply to 21G drives with enclosure code K, P, W, or Y).
CE	In conformity with these European Directives EMC Directive 2014/30/EU EN 61800-3 Low Voltage Directive 2014/35/EU EN 61800-5-1 ATEX Directive (2014/34/EU) EU-Type-Examination Certificate Number TÜV 12 ATEX 7328 X EN 50495

Certifications

Certification	Description
SEMI F47	Certified compliant with the following standards SEMI F47 IEC 61000-4-34
EAC	Low Voltage TP TC 004/2011 EMC TP TC 020/2011
Efficiency Class	Ecodesign regulation (EU) 2019/1781, IE2 efficiency class, refer to PowerFlex AC Drive Performance Specifications per Ecodesign Regulation (EU) 2019/1781, publication PFLEX-TD003 for additional information.
Functional Safety	TÜV Rheinland - Certification applies to 20-750-S, 20-750-S1, 20-750-S3, and 20-750-S4 Safety Options when installed in drive. Standards applied EN 61800-3, EN 61508 PARTS 1-7 EN 61800-5-1, EN 62061 EN 61800-5-2, EN 60204-1 EN ISO 13849-1
KCC	R-R-RAA-Drive See the certificate of registration for specific drive catalog numbers that have this certification. ⁽¹⁾
Lloyd's Register	Lloyd's Register Type Approval Certificate 11/60008 (For drives manufactured before 6/28/2016)
Morocco	Compliance to NM EN 61800-5-1
UKCA	Electromagnetic Compatibility Regulations (EMC) 2016 No. 1091 EN 61800-3 Electrical Equipment (Safety) Regulations (LV) 2016 No. 1101 EN 61800-5-1 Equipment and Protective Systems Intended for Use in Potentially Explosive Atmospheres Regulations (Ex) 2016 No. 1107 UK Type Examination Certificate Number TÜV 21 UKEX 7032 X EN 50495
RCM	Australian Communications and Media Authority In conformity with the following items Radiocommunications Act:1992 (including Amendments up to 2018) Radiocommunications (Electromagnetic Compatibility) Standard 2017 Radiocommunications Labeling (Electromagnetic Compatibility) Notice 2017 Standards applied EN 61800-3

(1) See the product certifications website, <http://www.rockwellautomation.com/global/certification/overview.page>, for declarations of conformity, certificates, and other certification details.

Environmental Specifications

Category	Specification																																	
Altitude	Based on load. See derating guidelines on pages 77...97 .																																	
	Based on voltage. See this table and the footnotes that are based on EN61800-5-1 (Electro-thermal Safety Standard for drives).																																	
	<table border="1"> <thead> <tr> <th rowspan="2">System and Ground Configuration</th> <th rowspan="2">Overvoltage Category⁽¹⁾</th> <th colspan="4">Altitude Limit Above Sea Level, m (ft)⁽²⁾⁽³⁾</th> </tr> <tr> <th>208/240V AC</th> <th>400/480V AC</th> <th>600V AC</th> <th>690V AC</th> </tr> </thead> <tbody> <tr> <td rowspan="2">Center grounded (Y neutral) (TT or TN-S)⁽⁴⁾</td> <td>II (2)</td> <td>9000 (29,527.5)⁽⁵⁾</td> <td>9000 (29,527.5)⁽⁵⁾</td> <td>7500 (24,606.3)⁽⁵⁾</td> <td>7500 (24,606.3)⁽⁵⁾</td> </tr> <tr> <td>III (3)</td> <td>9000 (29,527.5)⁽⁵⁾</td> <td>4800 (15,748.0)</td> <td>4800 (15,748.0)</td> <td>4800 (15,748.0)</td> </tr> <tr> <td>Ungrounded, impedance⁽⁶⁾ (IT)⁽⁴⁾</td> <td>II (2)</td> <td>9000 (29,527.5)⁽⁵⁾</td> <td>4800 (15,748.0)</td> <td>7500 (24,606.3)⁽⁵⁾</td> <td>4800 (15,748.0)</td> </tr> <tr> <td>Grounded, or corner grounded⁽⁶⁾</td> <td>III (3)</td> <td>4800 (15,748.0)</td> <td>2000 (6,561.7)</td> <td>4800 (15,748.0)</td> <td>2000 (6,561.7)</td> </tr> </tbody> </table>	System and Ground Configuration	Overvoltage Category ⁽¹⁾	Altitude Limit Above Sea Level, m (ft) ⁽²⁾⁽³⁾				208/240V AC	400/480V AC	600V AC	690V AC	Center grounded (Y neutral) (TT or TN-S) ⁽⁴⁾	II (2)	9000 (29,527.5) ⁽⁵⁾	9000 (29,527.5) ⁽⁵⁾	7500 (24,606.3) ⁽⁵⁾	7500 (24,606.3) ⁽⁵⁾	III (3)	9000 (29,527.5) ⁽⁵⁾	4800 (15,748.0)	4800 (15,748.0)	4800 (15,748.0)	Ungrounded, impedance ⁽⁶⁾ (IT) ⁽⁴⁾	II (2)	9000 (29,527.5) ⁽⁵⁾	4800 (15,748.0)	7500 (24,606.3) ⁽⁵⁾	4800 (15,748.0)	Grounded, or corner grounded ⁽⁶⁾	III (3)	4800 (15,748.0)	2000 (6,561.7)	4800 (15,748.0)	2000 (6,561.7)
	System and Ground Configuration			Overvoltage Category ⁽¹⁾	Altitude Limit Above Sea Level, m (ft) ⁽²⁾⁽³⁾																													
		208/240V AC	400/480V AC		600V AC	690V AC																												
Center grounded (Y neutral) (TT or TN-S) ⁽⁴⁾	II (2)	9000 (29,527.5) ⁽⁵⁾	9000 (29,527.5) ⁽⁵⁾	7500 (24,606.3) ⁽⁵⁾	7500 (24,606.3) ⁽⁵⁾																													
	III (3)	9000 (29,527.5) ⁽⁵⁾	4800 (15,748.0)	4800 (15,748.0)	4800 (15,748.0)																													
Ungrounded, impedance ⁽⁶⁾ (IT) ⁽⁴⁾	II (2)	9000 (29,527.5) ⁽⁵⁾	4800 (15,748.0)	7500 (24,606.3) ⁽⁵⁾	4800 (15,748.0)																													
Grounded, or corner grounded ⁽⁶⁾	III (3)	4800 (15,748.0)	2000 (6,561.7)	4800 (15,748.0)	2000 (6,561.7)																													
	<p>(1) Category II (Isolation Transformer Level) - Typically two levels of isolation or protection from outdoor power lines. Category III (most common) Distribution Level Inside a Building - Typically one level of isolation or protection from outdoor power lines.</p> <p>(2) Excluding failure from cosmic radiation. Cosmic radiation increases rate of IGBT malfunction at altitudes greater than 3000 m (9842.6) above sea level. Concrete walls and ceilings or concrete walls and large bottles of water overhead are examples of ways to shield against cosmic radiation.</p> <p>(3) Frame 1 drives are limited to a maximum of 2000 m (6,561.7 ft) thermally. See Derating Guidelines on page 70.</p> <p>(4) IEC Standard 60364</p> <p>(5) Drive is limited to a maximum of 4800 m (15,748.0 ft) thermally. See Derating Guidelines on page 70.</p> <p>(6) PowerFlex 755 Frame 1 can only be operated on a solidly grounded system.</p>																																	
Maximum surrounding air temperature IP20, NEMA/UL Open Type	0...50 °C (32...122 °F) Frames 1...5, all ratings																																	

Environmental Specifications (Continued)

Category	Specification																									
IP00, NEMA/UL Open Type	0...50 °C (32...122 °F) 0...40 °C (32...104 °F)	Frames 6 and 7, 12...456 A ratings Frame 7, 477 A rating																								
IP20, NEMA/UL Type 1 (with hood)	0...40 °C (32...104 °F)	Frames 1...5, all ratings																								
IP20, NEMA/UL Type 1 (with label)	0...40 °C (32...104 °F)	Frames 6 and 7, all ratings																								
IP00, NEMA/UL Open Type	0...40 °C (32...104 °F) ⁽¹⁾	Frames 8...10, all ratings																								
IP20, NEMA/UL Type 1	0...40 °C (32...104 °F) ⁽¹⁾	Frames 8...10, all ratings																								
IP54, NEMA 12	0...40 °C (32...104 °F) ⁽¹⁾	Frames 8...10, all ratings																								
Flange mount - front																										
IP20, NEMA/UL Open Type	0...50 °C (32...122 °F)	Frames 2...5, all ratings																								
IP00, NEMA/UL Open Type	0...50 °C (32...122 °F) 0...40 °C (32...104 °F)	Frames 6 and 7, 12...456 A ratings Frame 7, 477 A rating																								
Back/Heat sink																										
IP66, NEMA/UL Type 4X	0...40 °C (32...104 °F)	Frames 2...7, all ratings																								
Stand-alone/Wall-mount																										
IP54, NEMA/UL Type 12	0...40 °C (32...104 °F)	Frames 2...7, all ratings																								
Storage temperature (all constructions)	-40...70 °C (-40...158 °F)																									
Atmospheric protection	<p>IMPORTANT Do not install the drive in an area where the ambient atmosphere contains volatile or corrosive gas, vapors, or dust. If the drive is not going to be installed right away, store the drive in an area where it is not exposed to a corrosive atmosphere.</p>																									
IEC	<p>Conformity with IEC 60721-3-3, 3C3 and 3S2, for components manufactured by Rockwell Automation. A suitable IP54, UL Type 12 Cabinet is required to meet the 3S2 requirement.</p>																									
UV radiation	The HIM and IP54, NEMA/UL Type 12 drive plastics are not UV rated.																									
Relative humidity	5...95% noncondensing																									
Shock - operating	Frames 1...6 Frame 7 Frames 8...10	15 g peak for 11 ms duration (±1.0 ms) 10 g peak for 11 ms duration (±1.0 ms) Power core - 10 g peak for 11 ms duration (±1.0 ms) in cabinet with option bay - 5 g peak for 11 ms duration (±1.0 ms)																								
Shock - packaged for shipment	Frames 1 and 2 Frames 3 and 4 Frame 5 Frames 6...10	381 mm (15 in.) drop height 330 mm (13 in.) drop height 305 mm (12 in.) drop height Meets International Safe Transit Association (ISTA) test procedure 2B																								
Vibration - operating	Frames 1 and 2 Frames 3...5 Frames 6 and 7 Frames 8...10	1.000 mm (0.040 in.) displacement, 2 g peak 1.000 mm (0.040 in.) displacement, 1.5 g peak 1.000 mm (0.040 in.) displacement, 1 g peak Power core, drive in cabinet with option bay - 1.000 mm (0.040 in.) displacement, 1 g peak																								
Vibration - packaged for shipment, sinusoidal loose load	Frames 1...5 Frames 6...10	20.0 mm (0.8 in.) peak to peak, 2...5.186 Hz; 1.1 g peak from 5.186...20 Hz Meets ISTA 2B packaging standards																								
Vibration - packaged for shipment, random secured	Frames 1...5 Frames 6...10	<table border="1"> <thead> <tr> <th>Frequency (Hz)</th> <th>PSD (g²/Hz)</th> </tr> </thead> <tbody> <tr><td>1</td><td>0.00005</td></tr> <tr><td>4</td><td>0.01</td></tr> <tr><td>16</td><td>0.01</td></tr> <tr><td>40</td><td>0.001</td></tr> <tr><td>80</td><td>0.001</td></tr> <tr><td>200</td><td>0.00001</td></tr> </tbody> </table> <p>Meets International Safe Transit Association (ISTA) test procedure 2B.</p>	Frequency (Hz)	PSD (g ² /Hz)	1	0.00005	4	0.01	16	0.01	40	0.001	80	0.001	200	0.00001										
Frequency (Hz)	PSD (g ² /Hz)																									
1	0.00005																									
4	0.01																									
16	0.01																									
40	0.001																									
80	0.001																									
200	0.00001																									
Required airflow	<table border="1"> <thead> <tr> <th>Frame</th> <th>Total fan airflow</th> <th>Frame</th> <th>Total fan airflow</th> </tr> </thead> <tbody> <tr> <td>1 and 2</td> <td>84.95 m³/h (50 CFM)</td> <td>7</td> <td>1284.45 m³/h (756 CFM)</td> </tr> <tr> <td>3</td> <td>135.92 m³/h (80 CFM)</td> <td>8</td> <td>2293.67 m³/h (1350 CFM)</td> </tr> <tr> <td>4</td> <td>543.68 m³/h (320 CFM)</td> <td>9</td> <td>4587.33 m³/h (2700 CFM)</td> </tr> <tr> <td>5</td> <td>883.49 m³/h (520 CFM)</td> <td>10</td> <td>6880.99 m³/h (4050 CFM)</td> </tr> <tr> <td>6</td> <td>856.30 m³/h (504CFM)</td> <td></td> <td></td> </tr> </tbody> </table>	Frame	Total fan airflow	Frame	Total fan airflow	1 and 2	84.95 m ³ /h (50 CFM)	7	1284.45 m ³ /h (756 CFM)	3	135.92 m ³ /h (80 CFM)	8	2293.67 m ³ /h (1350 CFM)	4	543.68 m ³ /h (320 CFM)	9	4587.33 m ³ /h (2700 CFM)	5	883.49 m ³ /h (520 CFM)	10	6880.99 m ³ /h (4050 CFM)	6	856.30 m ³ /h (504CFM)			
Frame	Total fan airflow	Frame	Total fan airflow																							
1 and 2	84.95 m ³ /h (50 CFM)	7	1284.45 m ³ /h (756 CFM)																							
3	135.92 m ³ /h (80 CFM)	8	2293.67 m ³ /h (1350 CFM)																							
4	543.68 m ³ /h (320 CFM)	9	4587.33 m ³ /h (2700 CFM)																							
5	883.49 m ³ /h (520 CFM)	10	6880.99 m ³ /h (4050 CFM)																							
6	856.30 m ³ /h (504CFM)																									

Environmental Specifications (Continued)

Category	Specification																								
Sound Note: Sound pressure level is measured at 2 m (6.7 ft).	<table border="0"> <tr> <td>Frame</td> <td>Sound level</td> <td>Frame</td> <td>Sound level</td> </tr> <tr> <td>1 and 2</td> <td>63 dB</td> <td>7</td> <td>74 dB</td> </tr> <tr> <td>3</td> <td>64 dB</td> <td>8</td> <td>79 dB</td> </tr> <tr> <td>4</td> <td>72 dB</td> <td>9</td> <td>79 dB</td> </tr> <tr> <td>5</td> <td>77 dB</td> <td>10</td> <td>83 dB</td> </tr> <tr> <td>6</td> <td>73 dB</td> <td></td> <td></td> </tr> </table>	Frame	Sound level	Frame	Sound level	1 and 2	63 dB	7	74 dB	3	64 dB	8	79 dB	4	72 dB	9	79 dB	5	77 dB	10	83 dB	6	73 dB		
Frame	Sound level	Frame	Sound level																						
1 and 2	63 dB	7	74 dB																						
3	64 dB	8	79 dB																						
4	72 dB	9	79 dB																						
5	77 dB	10	83 dB																						
6	73 dB																								
Surrounding environment pollution degree Pollution Degree 1 and 2 Pollution Degree 3 and 4	See page 133 for descriptions of each pollution degree rating. All enclosures acceptable. Enclosure that meets or exceeds IP54, NEMA/UL Type 12 required.																								

(1) Maximum surrounding air temperature of 50 °C (122 °F) with derating. See [Derating Guidelines on page 70](#).

Technical Specifications

Category	Specification																																																																																																	
Protection	<table border="1"> <thead> <tr> <th rowspan="2"></th> <th colspan="6">Motor Voltage</th> </tr> <tr> <th>200/208V</th> <th>240V</th> <th>380/400V</th> <th>480V</th> <th>600V</th> <th>690V</th> </tr> </thead> <tbody> <tr> <td>AC input overvoltage trip</td> <td>288V AC</td> <td>288V AC</td> <td>576V AC</td> <td>576V AC</td> <td>714V AC (Frames 3...5) 825V AC (Frames 6...10)</td> <td>825V AC</td> </tr> <tr> <td>AC input undervoltage trip</td> <td>125V AC</td> <td>150V AC</td> <td>250V AC</td> <td>300V AC</td> <td>360V AC</td> <td>430V AC</td> </tr> <tr> <td>Bus overvoltage trip</td> <td>408V DC</td> <td>408V DC</td> <td>815V DC</td> <td>815V DC</td> <td>1013V DC (Frames 3...5) 1172V DC (Frames 6...10)</td> <td>1172V DC</td> </tr> <tr> <td>Bus undervoltage shutoff Frames 1...7 Frames 8...10</td> <td>150V DC —</td> <td>150V DC —</td> <td>200V DC 400V DC</td> <td>200V DC 400V DC</td> <td>200V DC (Frames 3...7) 400V DC</td> <td>200V DC (Frames 6 and 7) 400V DC</td> </tr> <tr> <td>Nominal bus voltage (full load)</td> <td>281V DC</td> <td>324V DC</td> <td>540V DC</td> <td>648V DC</td> <td>810V DC</td> <td>932V DC</td> </tr> <tr> <td>Drive overcurrent trip Software overcurrent trip Instantaneous current limit Hardware overcurrent trip</td> <td colspan="6">200% of drive rated 100% of 3 s rating (158...210%) 143% of 3 s rating (215...287%)</td> </tr> <tr> <td>Line transients</td> <td colspan="6">Up to 6000V peak per IEEE C62.41-1991</td> </tr> <tr> <td>Control logic noise immunity</td> <td colspan="6">Showering arc transients up to 1500V peak</td> </tr> <tr> <td>Power ride-through</td> <td colspan="6">15 ms at full load</td> </tr> <tr> <td>Logic control ride-through</td> <td colspan="6">0.5 s min, 2 s typical</td> </tr> <tr> <td>Ground fault trip</td> <td colspan="6">Phase-to-ground on drive output</td> </tr> <tr> <td>Short circuit trip</td> <td colspan="6">Phase-to-phase on drive output</td> </tr> </tbody> </table>		Motor Voltage						200/208V	240V	380/400V	480V	600V	690V	AC input overvoltage trip	288V AC	288V AC	576V AC	576V AC	714V AC (Frames 3...5) 825V AC (Frames 6...10)	825V AC	AC input undervoltage trip	125V AC	150V AC	250V AC	300V AC	360V AC	430V AC	Bus overvoltage trip	408V DC	408V DC	815V DC	815V DC	1013V DC (Frames 3...5) 1172V DC (Frames 6...10)	1172V DC	Bus undervoltage shutoff Frames 1...7 Frames 8...10	150V DC —	150V DC —	200V DC 400V DC	200V DC 400V DC	200V DC (Frames 3...7) 400V DC	200V DC (Frames 6 and 7) 400V DC	Nominal bus voltage (full load)	281V DC	324V DC	540V DC	648V DC	810V DC	932V DC	Drive overcurrent trip Software overcurrent trip Instantaneous current limit Hardware overcurrent trip	200% of drive rated 100% of 3 s rating (158...210%) 143% of 3 s rating (215...287%)						Line transients	Up to 6000V peak per IEEE C62.41-1991						Control logic noise immunity	Showering arc transients up to 1500V peak						Power ride-through	15 ms at full load						Logic control ride-through	0.5 s min, 2 s typical						Ground fault trip	Phase-to-ground on drive output						Short circuit trip	Phase-to-phase on drive output					
			Motor Voltage																																																																																															
		200/208V	240V	380/400V	480V	600V	690V																																																																																											
	AC input overvoltage trip	288V AC	288V AC	576V AC	576V AC	714V AC (Frames 3...5) 825V AC (Frames 6...10)	825V AC																																																																																											
	AC input undervoltage trip	125V AC	150V AC	250V AC	300V AC	360V AC	430V AC																																																																																											
	Bus overvoltage trip	408V DC	408V DC	815V DC	815V DC	1013V DC (Frames 3...5) 1172V DC (Frames 6...10)	1172V DC																																																																																											
	Bus undervoltage shutoff Frames 1...7 Frames 8...10	150V DC —	150V DC —	200V DC 400V DC	200V DC 400V DC	200V DC (Frames 3...7) 400V DC	200V DC (Frames 6 and 7) 400V DC																																																																																											
	Nominal bus voltage (full load)	281V DC	324V DC	540V DC	648V DC	810V DC	932V DC																																																																																											
	Drive overcurrent trip Software overcurrent trip Instantaneous current limit Hardware overcurrent trip	200% of drive rated 100% of 3 s rating (158...210%) 143% of 3 s rating (215...287%)																																																																																																
	Line transients	Up to 6000V peak per IEEE C62.41-1991																																																																																																
	Control logic noise immunity	Showering arc transients up to 1500V peak																																																																																																
	Power ride-through	15 ms at full load																																																																																																
	Logic control ride-through	0.5 s min, 2 s typical																																																																																																
	Ground fault trip	Phase-to-ground on drive output																																																																																																
Short circuit trip	Phase-to-phase on drive output																																																																																																	

Technical Specifications (Continued)

Category	Specification																		
Electrical	AC input voltage tolerance	See Input Voltage Tolerance on page 66 for full power and operating range.																	
	Frequency tolerance	47...63 Hz																	
	Input phases	Three-phase input provides full rating for all drives. For Frames 1...7 (output current up to 456 A), single-phase operation provides up to 50% of rated current at 25 °C (77 °F) surrounding temperature. Single-phase operation is not recommended for Frames 8 and larger.																	
	DC input voltage tolerance	±10% of nominal bus voltage (see Nominal bus voltage (full load) on page 63)																	
	Displacement power factor	0.98 across entire speed range																	
	DC link impedance	≤ 4%																	
	Efficiency	97.5% at rated amps, nominal line volts																	
	Maximum short circuit rating	200,000 A RMS symmetrical (20F and 20G drives only)																	
	Actual short circuit rating	Determined by AIC rating of installed fuse/circuit breaker. See page 120 for 21G drives.																	
	Drive to motor power ratio Min Max	Recommended not less than 1:2 ratio Recommended not greater than 2:1 ratio																	
	Brake IGBT rating	100% of motor-rated torque																	
	Control POD current draw	5 A																	
	Digital inputs Nominal Maximum High state Low state	<table border="0"> <tr> <td>DC</td> <td>AC</td> </tr> <tr> <td>24V DC</td> <td>120V AC</td> </tr> <tr> <td>30V DC</td> <td>132V AC</td> </tr> <tr> <td>20...24V DC</td> <td>100...132V AC</td> </tr> <tr> <td>0...5V DC</td> <td>0...30V AC</td> </tr> </table>	DC	AC	24V DC	120V AC	30V DC	132V AC	20...24V DC	100...132V AC	0...5V DC	0...30V AC							
	DC	AC																	
	24V DC	120V AC																	
	30V DC	132V AC																	
	20...24V DC	100...132V AC																	
0...5V DC	0...30V AC																		
PTC inputs Standard Trip resistance Nominal resistance Reset resistance Short circuit trip resistance	<table border="0"> <tr> <td>PowerFlex 753 MCB</td> <td>22-Series I/O option module</td> <td>ATEX option module for 11-Series I/O option module</td> </tr> <tr> <td>N/A ⁽¹⁾</td> <td>DIN 44082</td> <td>IEC 6094-8</td> </tr> <tr> <td>3.1 kΩ</td> <td>3.1 kΩ</td> <td>3.2 kΩ</td> </tr> <tr> <td>1.8 kΩ</td> <td>1.8 kΩ</td> <td>1.6 kΩ</td> </tr> <tr> <td>2.2 kΩ</td> <td>2.2 kΩ</td> <td>N/A ⁽³⁾</td> </tr> <tr> <td>N/A ⁽²⁾</td> <td>80 Ω</td> <td>100 Ω</td> </tr> </table> <p>(1) Not designed to a standard. (2) No short circuit fault. (3) No hysteresis, fault is latched.</p>	PowerFlex 753 MCB	22-Series I/O option module	ATEX option module for 11-Series I/O option module	N/A ⁽¹⁾	DIN 44082	IEC 6094-8	3.1 kΩ	3.1 kΩ	3.2 kΩ	1.8 kΩ	1.8 kΩ	1.6 kΩ	2.2 kΩ	2.2 kΩ	N/A ⁽³⁾	N/A ⁽²⁾	80 Ω	100 Ω
PowerFlex 753 MCB	22-Series I/O option module	ATEX option module for 11-Series I/O option module																	
N/A ⁽¹⁾	DIN 44082	IEC 6094-8																	
3.1 kΩ	3.1 kΩ	3.2 kΩ																	
1.8 kΩ	1.8 kΩ	1.6 kΩ																	
2.2 kΩ	2.2 kΩ	N/A ⁽³⁾																	
N/A ⁽²⁾	80 Ω	100 Ω																	
Battery	User-installed CR1220 lithium coin cell battery provides power to the real-time clock (optional, not supplied). Preserves the clock setting in the event power to the drive is lost or cycled. Approximate life is 4.5 years with drive unpowered, or lifetime if drive is powered.																		

Technical Specifications (Continued)

Category	Specification															
Control	Method	Sine coded PWM with programmable carrier frequency. Ratings apply to all drives.														
	Carrier frequency	<table border="0"> <tr> <td>Default settings</td> <td></td> </tr> <tr> <td>Frames 1...3</td> <td>4 kHz</td> </tr> <tr> <td>Frames 4...10</td> <td>2 kHz</td> </tr> <tr> <td>Settings</td> <td></td> </tr> <tr> <td>Frames 1...6</td> <td>2, 4, 8, 12 kHz ^{(1) (2)}</td> </tr> <tr> <td>Frame 7</td> <td>2, 4, 8 kHz ⁽¹⁾</td> </tr> <tr> <td>Frames 8...10</td> <td>2, 4 kHz</td> </tr> </table>	Default settings		Frames 1...3	4 kHz	Frames 4...10	2 kHz	Settings		Frames 1...6	2, 4, 8, 12 kHz ^{(1) (2)}	Frame 7	2, 4, 8 kHz ⁽¹⁾	Frames 8...10	2, 4 kHz
	Default settings															
	Frames 1...3	4 kHz														
	Frames 4...10	2 kHz														
	Settings															
	Frames 1...6	2, 4, 8, 12 kHz ^{(1) (2)}														
	Frame 7	2, 4, 8 kHz ⁽¹⁾														
	Frames 8...10	2, 4 kHz														
	Output voltage range	0 to rated motor voltage														
	Output frequency range	0...325 Hz at 2 kHz carrier 0...590 Hz at 4 kHz carrier														
	Frequency accuracy															
	Digital input	Within $\pm 0.01\%$ of set output frequency														
	Analog input	Within $\pm 0.4\%$ of maximum output frequency														
	Frequency control	Speed regulation – with slip compensation (V/Hz and Sensorless Vector modes) 0.5% of base speed across 40:1 speed range, 40:1 operating range														
	Speed control	Without feedback (Flux Vector mode), 0.1% of base speed across 100:1 speed range, 120:1 operating range, 50 rad/s bandwidth														
		With feedback (Flux Vector mode), 0.001% of base speed across 100:1 speed range, 1000:1 operating range, 190 rad/s bandwidth														
Torque regulation	Without feedback (Flux Vector mode), $\pm 5\%$, 600 rad/s bandwidth															
	With feedback (Flux Vector mode), $\pm 2\%$, 2500 rad/s bandwidth															
Selectable motor control	<ul style="list-style-type: none"> • Standard V/Hz with full custom capability • Sensorless Vector mode with full tuning • Flux Vector mode with and without a feedback device • Induction motor control • Surface-mount permanent magnet motor control with encoder feedback (Frames 1...10)⁽³⁾ • Surface-mount permanent magnet motor control without encoder feedback (Frames 1...7)⁽³⁾ • Internal permanent-magnet motor control with encoder feedback (Frames 1...10) • Internal permanent-magnet motor control without encoder feedback (Frames 1...7) 															
Stop modes	Multiple programmable stop modes including - Ramp, Coast, DC-Brake, Ramp-to-Hold, Fast Braking, and Current Limit Stop.															
Accel/Decel	Two independently programmable accel and decel times. Each time can be programmed from 0...3600 seconds in 0.1 second increments (0 to motor nameplate speed).															
S-curve time	Adjustable from 0...100% of ramp time (normal duty rating)															
Intermittent overload	Light duty (only Frames 8...10)	110% overload capability for up to 1 min out of 10 min														
	Normal duty	110% overload capability for up to 1 min out of 10 min 150% overload capability for up to 3 s out of 60 s														
	Heavy duty	150% overload capability for up to 1 min out of 10 min 180% overload capability for up to 3 s out of 60 s														
Current limit capability	Proactive current limit programmable from 20...160% of rated output current. Independently programmable proportional and integral gain.															
Electronic motor overload protection	Class 10 motor overload protection according to NEC article 430 and motor over-temperature protection according to NEC article 430.126 (A)(2). UL 508C File E59272.															

(1) Frames 6 and 7 600/690V AC input drives can be set to 2 kHz or 4 kHz.

(2) Frames 3...5 600/690V AC input drives can be set to 2, 4, or 8 kHz.

(3) Only PowerFlex 755 drives.

Design Considerations

This section provides information for design considerations.

Input Voltage Tolerance

Table 0.A

Drive Rating	Nominal Line Voltage	Nominal Motor Voltage	Drive Full Power Range	Drive Operating Range
200...240	200	200	200...264	180...264
	208	208	208...264	
	240	230	230...264	
380...480	380	380	380...528	342...528
	400	400	400...528	
	480	460	460...528	
600...690	600	575	575...759	517...759
	690	660	660...759	
Drive full power range =	Nominal motor voltage to drive-rated voltage + 10%. Rated current is available across the entire drive full-power range.			
Drive operating range =	Lowest nominal motor voltage - 10% to drive-rated voltage + 10%. Drive output is linearly created when actual line voltage is less than the nominal motor voltage			

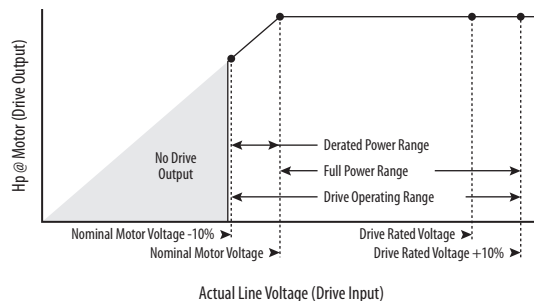

EXAMPLE

Calculate the maximum power of a 5.0 Hp, 460V motor connected to a 480V-rated drive supplied with 342V actual line voltage input.

- Actual line voltage/nominal motor voltage = 74.3%
 - 74.3% x 5.0 Hp = 3.7 Hp
 - 74.3% x 60 Hz = 44.6 Hz
- At 342V actual line voltage, the maximum power the 5.0 Hp, 460V motor can produce is 3.7 Hp at 44.6 Hz.

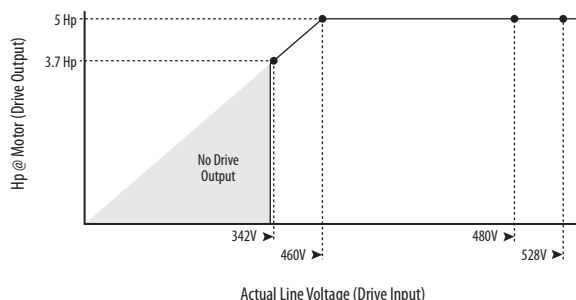

IMPORTANT

For maximum protection of the drive and its internal components, we recommend the use of semiconductor fuses to other methods of circuit protection. Semiconductor fuses reduce the risk of drive damage from power quality events and improves machine and process utilization.

Approximate Watts Loss

The following table lists watts loss data for PowerFlex 750-Series drives running at full load, full speed, and default carrier frequency.

Internal watts are the watts that the control structure of the drive dissipates into the cabinet, regardless of mounting style. External watts are the watts that are dissipated directly through the heatsink and are outside the cabinet for flange mount, and inside the cabinet for other mounting types.

Watts Loss for 208/240V Drives

Drive Cat. No. (1)(2)	Normal Duty		External Watts (3)	Internal Watts (3)	Total Watts (3)	Drive Cat. No. (1)(2)	Normal Duty		External Watts (3)	Internal Watts (3)	Total Watts (3)
	kW	Continuous Output Amps (3)					Hp	Continuous Output Amps			
208V						240V					
20x...B2P2	0.37	2.5	34 (23)	57 (57)	91 (80)	20x...B2P2	0.5	2.2	29 (20)	61 (56)	90 (76)
20x...B4P2	0.75	4.8	63 (46)	60 (62)	124 (108)	20x...B4P2	1	4.2	52 (40)	63 (60)	115 (100)
20x...B6P8	1.5	7.8	80 (72)	64 (75)	144 (147)	20x...B6P8	2	6.8	67 (61)	66 (71)	133 (132)
20x...B9P6	2.2	11	110 (99)	70 (82)	180 (181)	20x...B9P6	3	9.6	92 (84)	71 (76)	163 (160)
20x...B015	4	17.5 (15.3)	169 (157)	76 (79)	245 (236)	20x...B015	5	15.3	141 (158)	76 (80)	217 (238)

Watts Loss for 208/240V Drives (Continued)

Drive Cat. No. (1)(2)	Normal Duty		External Watts (3)	Internal Watts (3)	Total Watts (3)	Drive Cat. No. (1)(2)	Normal Duty		External Watts (3)	Internal Watts (3)	Total Watts (3)
	kW	Continuous Output Amps (3)					Hp	Continuous Output Amps			
20x...B022	5.5	22	237	87	324	20x...B022	7.5	22	240	92	331
20x...B028	7.5	32.2	328	104	432	20x...B028	10	28	272	98	370
20x...B042	11	43	459	122	581	20x...B042	15	42	458	125	583
20x...B054	15	60	505	132	637	20x...B054	20	54	439	128	567
20x...B070	18.5	78.2	643	152	796	20x...B070	25	70	557	146	703
20x...B080	22	92	788	181	969	20x...B080	30	80	653	163	816
20x...B104	30	120	1054	274	1327	20x...B104	40	104	874	252	1126
20x...B130	37	150	1184	266	1449	20x...B130	50	130	997	248	1245
20x...B154	45	177	1492	317	1808	20x...B154	60	154	1250	288	1538
20x...B192	55	221	1921	403	2324	20x...B192	75	192	1597	355	1952
20x...B260	66	260	2418	499	2917	20x...B260	100	260	2426	513	2939
20x...B312	90	359	3120	561	3681	20x...B312	125	312	2602	491	3094
20x...B360	110	414	3384	646	4029	20x...B360	150	360	2817	557	3373
20x...B477	132	477	4135	789	4924	20x...B477	200	477	4156	810	4966

(1) Select the watts loss based on the catalog number.

(2) Frames 8...10, enclosure codes B, J, L, P, and W.

(3) Frame 1 watts loss in parentheses.

Watts Loss for 400/480V Drives

Drive Cat. No. (1)(2)	Normal Duty		External Watts (3)	Internal Watts (3)	Total Watts (3)	Drive Cat. No. (1)(2)	Normal Duty		External Watts (3)	Internal Watts (3)	Total Watts (3)
	kW	Continuous Output Amps					Hp	Continuous Output Amps			
400V						480V					
20x...C2P1	0.75	2.1	16 (16)	55 (56)	71 (72)	20x...D2P1	1.0	2.1	17 (21)	60 (61)	77 (82)
20x...C3P5	1.5	3.5	26 (33)	57 (60)	83 (93)	20x...D3P4	2.0	3.4	27 (39)	61 (64)	88 (103)
20x...C5P0	2.2	5	39 (44)	58 (62)	97 (106)	20x...D5P0	3.0	5	41 (54)	63 (67)	104 (121)
20x...C8P7	4.0	8.7	75 (79)	64 (80)	139 (159)	20x...D8P0	5.0	8	71 (91)	68 (82)	139 (173)
20x...C011	5.5	11.5	108 (107)	70 (85)	178 (192)	20x...D011	7.5	11	108 (118)	74 (88)	182 (206)
20x...C015	7.5	15.4	161 (166)	80 (80)	241 (246)	20x...D014	10	14	149 (152)	81 (81)	230 (233)
20x...C022	11	22	225	86	311	20x...D022	15	22	237	91	328
20x...C030	15	30	300	103	403	20x...D027	20	27	273	101	374
20x...C037	18.5	37	362	115	477	20x...D034	25	34	368	115	483
20x...C043	22	43	505	126	631	20x...D040	30	40	503	126	629
20x...C060	30	60	487	130	617	20x...D052	40	52	422	125	547
20x...C072	37	72	615	147	762	20x...D065	50	65	559	144	703
20x...C085	45	85	705	162	867	20x...D077	60	77	646	158	804
20x...C104	55	104	928	201	1129	20x...D096	75	96	855	189	1044
20x...C140	75	140	1239	319	1558	20x...D125	100	125	1109	299	1408
20x...C170	90	170	1381	300	1681	20x...D156	125	156	1299	294	1593
20x...C205	110	205	1893	381	2274	20x...D186	150	186	1718	358	2076
20x...C260	132	260	2449	502	2951	20x...D248	200	248	2384	492	2876
20x...C302	160	302	2566	461	3027	20x...D302	250	302	2704	491	3195
20x...C367	200	367	3322	586	3908	20x...D361	300	361	3409	606	4015
20x...C456	250	456	3922	743	4665	20x...D415	350	415	3604	683	4287
2xG...C460	250	460	4779	1090	5869	2xG...D430	350	430	4385	971	5356
20x...C477	270	477	4199	793	4992	20x...D477	400	477	4392	828	5220
2xG...C540	315	540	5316	1216	6532	2xG...D485	400	485	5091	1126	6217
2xG...C567	315	567	5652	1298	6950	2xG...D545	450	545	5649	1253	6902

Watts Loss for 400/480V Drives (Continued)

Drive Cat. No. (1)(2)	Normal Duty		External Watts (3)	Internal Watts (3)	Total Watts (3)	Drive Cat. No. (1)(2)	Normal Duty		External Watts (3)	Internal Watts (3)	Total Watts (3)
	kW	Continuous Output Amps					Hp	Continuous Output Amps			
2xG...C650	355	650	7011	1577	8588	2xG...D617	500	617	6942	1489	8431
2xG...C750	400	750	7577	1726	9303	2xG...D710	600	710	7631	1659	9290
2xG...C770	400	770	8086	1848	9934	2xG...D740	650	740	8133	1776	9909
2xG...C910	500	910	9155	2251	11406	2xG...D800	700	800	8710	2216	10926
2xG...C1K0	560	1040	9732	2357	12089	2xG...D960	800	960	9696	2391	12087
2xG...C1K1	630	1090	10745	2548	13293	2xG...D1K0	900	1045	10784	2589	13373
2xG...C1K2	710	1175	13778	2978	16756	2xG...D1K2	1000	1135	13378	2899	16277
2xG...C1K4	800	1465	13959	3013	16973	2xG...D1K3	1100	1365	14055	3025	17080
2xG...C1K5	850	1480	15441	3308	18749	2xG...D1K4	1250	1420	15573	3314	18887
2xG...C1K6	900	1590	15569	3717	19286	2xG...D1K5	1350	1525	15619	3779	19398
2xG...C2K1	1250	2150	22320	4790	27110	2xG...D2K0	1750	2070	22495	4802	27297

- (1) Select the watts loss based on the catalog number.
- (2) Frames 8...10, enclosure codes B, J, L, P, and W.
- (3) Frame 1 watts loss in parentheses.

Watts Loss for 600/690V Drives

Drive Cat. No. (1)(2)	Normal Duty		External Watts	Internal Watts	Total Watts	Drive Cat. No. (1)(2)	Normal Duty		External Watts	Internal Watts	Total Watts
	kW	Continuous Output Amps					Hp	Continuous Output Amps			
690V						600V					
						20x...E1P7	1.0	1.7	23	15	38
						20x...E2P7	2.0	2.7	40	17	57
						20x...E3P9	3.0	3.9	51	18	69
						20x...E6P1	5.0	6.1	80	22	103
						20x...E9P0	7.5	9	122	29	150
						20x...E011	10	11	152	34	186
20x...F012	7.5	12	169	50	219	20x...E012	10	12	168	50	217
						20x...E017	15	17	249	54	302
						20x...F015	11	15	226	56	282
						20x...E022	20	22	329	74	403
						20x...F020	15	20	296	65	361
20x...F023	18.5	23	327	70	397	20x...E024	20	24	326	71	397
						20x...E027	25	27	411	84	494
						20x...F030	22	30	428	85	513
						20x...E032	30	32	503	105	608
						20x...F034	30	34	478	94	573
						20x...E041	40	41	590	128	718
						20x...F046	37	46	649	126	775
						20x...E052	50	52	784	176	959
						20x...F050	45	50	699	138	836
20x...F061	55	61	760	130	891	20x...E063	60	63	757	132	889
20x...F082	75	82	1044	182	1226	20x...E077	75	77	935	166	1101
20x...F098	90	98	1310	231	1541	20x...E099	100	99	1269	229	1499
20x...F119	110	119	1658	302	1961	20x...E125	125	125	1678	318	1996
20x...F142	132	142	2003	387	2391	20x...E144	150	144	1960	389	2349
20x...F171	160	171	2655	389	3044	20x...E192	200	192	2801	433	3234
20x...F212	200	212	3375	513	3889	20x...E242	250	242	3642	593	4235
20x...F263	250	263	4286	690	4976	20x...E289	300	289	4437	762	5200

Watts Loss for 600/690V Drives (Continued)

Drive Cat. No. (1)(2)	Normal Duty		External Watts	Internal Watts	Total Watts	Drive Cat. No. (1)(2)	Normal Duty		External Watts	Internal Watts	Total Watts
	kW	Continuous Output Amps					Hp	Continuous Output Amps			
2xG...F265	250	265	4314	996	5310	2xG...E295	300	295	4592	1030	5622
2xG...F330	315	330	5160	1127	6287	2xG...E355	350	355	5191	1131	6321
2xG...F370	355	370	5803	1233	7036	2xG...E395	400	395	5812	1240	7052
2xG...F415	400	415	5865	1211	7076	2xG...E435	450	435	5590	1163	6753
2xG...F460	450	460	6638	1337	7975	2xG...E460	500	460	6407	1301	7708
2xG...F500	500	500	7117	1417	8534	2xG...E510	500	510	6946	1396	8342
2xG...F590	560	590	8941	2077	11019	2xG...E595	600	595	8903	2053	10956
2xG...F650	630	650	9865	2220	12085	2xG...E630	700	630	9942	2225	12167
2xG...F710	710	710	11136	2425	13561	2xG...E760	800	760	11093	2424	13517
2xG...F765	750	765	11139	2368	13507	2xG...E825	900	825	11046	2342	13389
2xG...F795	800	795	12663	2611	15275	2xG...E900	950	900	12225	2539	14764
2xG...F960	900	860	13608	2767	16375	2xG...E980	1000	980	13211	2709	15920
2xG...F1K0	1000	1040	16147	3545	19692	2xG...E1K1	1100	1110	16169	3552	19720
2xG...F1K4	1400	1400	19716	4034	23750	2xG...E1K4	1400	1430	19256	3966	23222

(1) Select the watts loss based on the catalog number.

(2) Frames 8...10, enclosure codes B, L, P, and W.

Additional Watts Loss for Cabinet Options Bay

Drive Cat. No. (1)	Normal Duty		Cabinet Options Bay		Drive Cat. No. (1)	Normal Duty		Cabinet Options Bay	
	kW	Continuous Output Amps	Without Input or Output Line Reactor (Watts) (2)	With Input or Output Line Reactor (Watts) (2)		Hp	Continuous Output Amps	Without Input or Output Line Reactor (Watts) (2)	With Input or Output Line Reactor (Watts) (2)
400V					480V				
21G...C460	250	460	219	626	21G...D430	350	430	177	652
21G...C540	315	540	256	735	21G...D485	400	485	204	652
21G...C567	315	567	280	792	21G...D545	450	545	239	725
21G...C650	355	650	359	1123	21G...D617	500	617	295	983
21G...C750	400	750	404	1549	21G...D710	600	710	355	1410
21G...C770	400	770	441	1692	21G...D740	650	740	388	1542
21G...C910	500	910	327	2425	21G...D800	700	800	246	1867
21G...C1K0	560	1040	350	2651	21G...D960	800	960	364	2325
21G...C1K1	630	1090	384	2912	21G...D1K0	900	1045	353	2677
21G...C1K2	710	1175	446	3384	21G...D1K2	1000	1135	416	3158
21G...C1K4	800	1465	662	3520	21G...D1K3	1100	1365	574	3056
21G...C1K5	850	1480	675	3593	21G...D1K4	1250	1420	622	3307
690V					600V				
21G...F265	250	265	266	1090	21G...E295	300	295	233	838
21G...F330	315	330	304	1067	21G...E355	350	355	289	902
21G...F370	355	370	343	1288	21G...E395	400	395	328	759
21G...F415	400	415	379	1547	21G...E435	450	435	354	1208
21G...F460	450	460	240	1195	21G...E460	500	460	379	1327
21G...F500	500	500	251	1315	21G...E510	500	510	410	1450
21G...F590	560	590	134	2617	21G...E595	600	595	136	1659
21G...F650	630	650	162	3175	21G...E630	700	630	153	1860
21G...F710	710	710	194	2362	21G...E760	800	760	222	2706

Additional Watts Loss for Cabinet Options Bay (Continued)

Drive Cat. No. (1)	Normal Duty		Cabinet Options Bay		Drive Cat. No. (1)	Normal Duty		Cabinet Options Bay	
	kW	Continuous Output Amps	Without Input or Output Line Reactor (Watts) (2)	With Input or Output Line Reactor (Watts) (2)		Hp	Continuous Output Amps	Without Input or Output Line Reactor (Watts) (2)	With Input or Output Line Reactor (Watts) (2)
21G...F765	750	765	225	2742	21G...E825	900	825	269	3196
21G...F795	800	795	243	2961	21G...E900	950	900	320	2372
21G...F960	900	960	364	2699	21G...E980	1000	980	310	2744

(1) Select the watts loss based on the catalog number.

(2) For MCC power bus options, add the following watts: 1250 A power bus = 188 watts; 2000 A power bus = 261 watts; 3200 A power bus = 421 watts.

Derating Guidelines

If a catalog number is not shown, you can operate that drive without derating as long as the limits specified on [page 61](#) and [page 63](#) are followed.

Ambient Temperature/Load and Altitude/Load – 208V AC (Frames 1...7)

Cat. No. (see page 5)	208V AC Power Rating						Derating for IP20 NEMA/UL Type Open (Frames 1...5) and IP00 NEMA/UL Type Open (Frames 6 and 7) (1)			
	Light Duty		Normal Duty		Heavy Duty		Ambient Temperature/Load		Altitude/Load	
	kW	Cont. Amps	kW	Cont. Amps	kW	Cont. Amps				
20x...B6P8 (Frame 1)	-	-	1.5	7.8	0.75	4.8				
20x...B9P6 (Frame 1)	-	-	2.2	11	1.5	7.8				
20x...B015 (Frame 1)	-	-	4	15.3	2.2	11				

Ambient Temperature/Load and Altitude/Load – 208V AC (Frames 1...7) (Continued)

Cat. No. (see page 5)	208V AC Power Rating						Derating for IP20 NEMA/UL Type Open (Frames 1...5) and IPO0 NEMA/UL Type Open (Frames 6 and 7) ⁽¹⁾			
	Light Duty		Normal Duty		Heavy Duty		Ambient Temperature/Load		Altitude/Load	
	kW	Cont. Amps	kW	Cont. Amps	kW	Cont. Amps				
20x...B015 (Frame 2)	-	-	4	17.5	2.2	11				
20x...B022	-	-	5.5	22	4	17.5				
20x...B028	-	-	7.5	32.2	5.5	22				
20x...B042	-	-	11	43	7.5	32.2				
20x...B054	-	-	15	60	11	43				

Ambient Temperature/Load and Altitude/Load – 208V AC (Frames 1...7) (Continued)

Cat. No. (see page 5)	208V AC Power Rating						Derating for IP20 NEMA/UL Type Open (Frames 1...5) and IP00 NEMA/UL Type Open (Frames 6 and 7) ⁽¹⁾	
	Light Duty		Normal Duty		Heavy Duty		Ambient Temperature/Load	
	kW	Cont. Amps	kW	Cont. Amps	kW	Cont. Amps	Altitude/Load	
20x...B070	-	-	18.5	78.2	15	60		
20x...B080	-	-	22	92	18.5	78.2		
20x...B104	-	-	30	120	22	92		
20x...B130	-	-	37	1550	30	120		
20x...B154	-	-	45	177	37	150		

Ambient Temperature/Load and Altitude/Load – 208V AC (Frames 1...7) (Continued)

Cat. No. (see page 5)	208V AC Power Rating						Derating for IP20 NEMA/UL Type Open (Frames 1...5) and IPO0 NEMA/UL Type Open (Frames 6 and 7) ⁽¹⁾	
	Light Duty		Normal Duty		Heavy Duty		Ambient Temperature/Load	
	kW	Cont. Amps	kW	Cont. Amps	kW	Cont. Amps	Altitude/Load	
20x...B192	-	-	55	221	45	177		
20x...B260	-	-	66	260	55	221		
20x...B312	-	-	90	359	66	260		
20x...B360	-	-	110	414	90	359		
20x...B477	-	-	132	477	90	359		

(1) Other enclosure types follow the same derating, while not exceeding, the maximum surrounding air temperature listed in [Environmental Specifications on page 61](#).

Ambient Temperature/Load and Altitude/Load – 240V AC (Frames 1...7)

Cat. No. (see page 5)	240V AC Power Rating						Derating for IP20 NEMA/UL Type Open (Frames 1...5) and IP00 NEMA/UL Type Open (Frames 6 and 7) ⁽¹⁾	
	Light Duty		Normal Duty		Heavy Duty		Ambient Temperature/Load	Altitude/Load
	Hp	Cont. Amps	Hp	Cont. Amps	Hp	Cont. Amps	— 2 kHz - - - 4 kHz - - - 8 kHz — 12 kHz — 2 kHz w/Cabinet Option (21G) — 4 kHz w/Cabinet Option (21G)	
20x...B6P8 (Frame 1)	-	-	2	6.8	1	4.2		
20x...B9P6 (Frame 1)	-	-	3	9.6	2	6.8		
20x...B015 (Frame 1)	-	-	5	15.3	3	9.6		
20x...B015 (Frame 2)	-	-	5	15.3	3	9.6		
20x...B022	-	-	7.5	22	5	15.3		

Ambient Temperature/Load and Altitude/Load – 240V AC (Frames 1...7) (Continued)

Cat. No. (see page 5)	240V AC Power Rating						Derating for IP20 NEMA/UL Type Open (Frames 1...5) and IPO0 NEMA/UL Type Open (Frames 6 and 7) ⁽¹⁾	
	Light Duty		Normal Duty		Heavy Duty		Ambient Temperature/Load	
	Hp	Cont. Amps	Hp	Cont. Amps	Hp	Cont. Amps	Altitude/Load	
20x...B028	-	-	10	28	7.5	22		
20x...B042	-	-	15	42	10	28		
20x...B054	-	-	20	54	15	42		
20x...B070	-	-	25	70	20	54		
20x...B080	-	-	30	80	25	75		

Ambient Temperature/Load and Altitude/Load – 240V AC (Frames 1...7) (Continued)

Cat. No. (see page 5)	240V AC Power Rating						Derating for IP20 NEMA/UL Type Open (Frames 1...5) and IP00 NEMA/UL Type Open (Frames 6 and 7) ⁽¹⁾	
	Light Duty		Normal Duty		Heavy Duty		Ambient Temperature/Load	
	Hp	Cont. Amps	Hp	Cont. Amps	Hp	Cont. Amps	Altitude/Load	
20x...B104	-	-	40	104	30	80		
20x...B130	-	-	50	130	40	104		
20x...B154	-	-	60	154	50	130		
20x...B192	-	-	75	192	60	154		
20x...B260	-	-	100	260	75	192		

Ambient Temperature/Load and Altitude/Load – 240V AC (Frames 1...7) (Continued)

Cat. No. (see page 5)	240V AC Power Rating						Derating for IP20 NEMA/UL Type Open (Frames 1...5) and IPO0 NEMA/UL Type Open (Frames 6 and 7) ⁽¹⁾	
	Light Duty		Normal Duty		Heavy Duty		Ambient Temperature/Load	Altitude/Load
	Hp	Cont. Amps	Hp	Cont. Amps	Hp	Cont. Amps		
20x...B312	-	-	125	312	100	260		
20x...B360	-	-	150	360	125	312		
20x...B477	-	-	200	477	125	312		

(1) Other enclosure types follow the same derating, while not exceeding, the maximum surrounding air temperature listed in [Environmental Specifications on page 61](#).

Ambient Temperature/Load and Altitude/Load – 400V AC (Frames 1...7)

Cat. No. (see page 5)	400V AC Power Rating						Derating for IP20 NEMA/UL Type Open (Frames 1...5) and IPO0 NEMA/UL Type Open (Frames 6 and 7) ⁽¹⁾	
	Light Duty		Normal Duty		Heavy Duty		Ambient Temperature/Load	Altitude/Load
	kW	Cont. Amps	kW	Cont. Amps	kW	Cont. Amps		
20x...C8P7 (Frame 1)	-	-	4.0	8.7	2.2	5.0		

Ambient Temperature/Load and Altitude/Load – 400V AC (Frames 1...7) (Continued)

Cat. No. (see page 5)	400V AC Power Rating						Derating for IP20 NEMA/UL Type Open (Frames 1...5) and IP00 NEMA/UL Type Open (Frames 6 and 7) ⁽¹⁾	
	Light Duty		Normal Duty		Heavy Duty		Ambient Temperature/Load	
	kW	Cont. Amps	kW	Cont. Amps	kW	Cont. Amps	Altitude/Load	
20x...C011 (Frame 1)	-	-	5.5	11.5	4.0	8.7		
20x...C015 (Frame 1)	-	-	7.5	15.4	5.5	11.5		
20x...C015 (Frame 2)	-	-	7.5	15.4	5.5	11.5		
20x...C022	-	-	11	22	7.5	15.4		
20x...C030	-	-	15	30	11	22		

Ambient Temperature/Load and Altitude/Load – 400V AC (Frames 1...7) (Continued)

Cat. No. (see page 5)	400V AC Power Rating						Derating for IP20 NEMA/UL Type Open (Frames 1...5) and IPO0 NEMA/UL Type Open (Frames 6 and 7) ⁽¹⁾	
	Light Duty		Normal Duty		Heavy Duty		Ambient Temperature/Load	
	kW	Cont. Amps	kW	Cont. Amps	kW	Cont. Amps	Altitude/Load	
20x...C037	-	-	18.5	37	15	30		
20x...C043	-	-	22	43	18.5	37		
20x...C060	-	-	30	60	22	43		
20x...C072	-	-	37	72	30	60		
20x...C085	-	-	45	85	37	72		

Ambient Temperature/Load and Altitude/Load – 400V AC (Frames 1...7) (Continued)

Cat. No. (see page 5)	400V AC Power Rating						Derating for IP20 NEMA/UL Type Open (Frames 1...5) and IP00 NEMA/UL Type Open (Frames 6 and 7) ⁽¹⁾	
	Light Duty		Normal Duty		Heavy Duty		Ambient Temperature/Load	
	kW	Cont. Amps	kW	Cont. Amps	kW	Cont. Amps	Altitude/Load	
20x...C104	-	-	55	104	45	85		
20x...C140	-	-	75	140	55	104		
20x...C170	-	-	90	170	75	140		
20x...C205	-	-	110	205	90	170		
20x...C260	-	-	132	260	110	205		

Ambient Temperature/Load and Altitude/Load – 400V AC (Frames 1...7) (Continued)

Cat. No. (see page 5)	400V AC Power Rating						Derating for IP20 NEMA/UL Type Open (Frames 1...5) and IP00 NEMA/UL Type Open (Frames 6 and 7) ⁽¹⁾	
	Light Duty		Normal Duty		Heavy Duty		Ambient Temperature/Load	
	kW	Cont. Amps	kW	Cont. Amps	kW	Cont. Amps	Altitude/Load	
20x...C302	-	-	160	302	132	260		
20x...C367	-	-	200	367	160	302		
20x...C456	-	-	250	456	200	367		
20x...C477	-	-	270	477	200	367		

(1) Other enclosure types follow the same derating, while not exceeding, the maximum surrounding air temperature listed in [Environmental Specifications on page 61](#).

Ambient Temperature/Load and Altitude/Load – 400V AC (Frames 8...10)

Cat. No. (see page 5)	400V AC, Power Rating at 40 °C (104 °F) (Power Rating at 50 °C [122 °F])						Derating for IP20 NEMA/UL Type 1 (Frames 8...10), IP00 NEMA/UL Type 0 (Frames 8...10), and IP54 NEMA/UL Type 12 (Frames 8...10)											
	Light Duty		Normal Duty		Heavy Duty		Ambient Temperature/Load						Altitude/Load					
	kW	Cont. Amps	kW	Cont. Amps	kW	Cont. Amps	— 2 kHz — 4 kHz — 8 kHz — 12 kHz						— 2 kHz w/Cabinet Option (21G) — 4 kHz w/Cabinet Option (21G)					
2xG...C460	315 (200)	540 (421)	250 (186)	460 (359)	200 (160)	385 (300)												
2xG...C540	315 (250)	585 (456)	315 (224)	540 (421)	250 (186)	456 (356)												
2xG...C567	355 (250)	612 (477)	315 (250)	567 (442)	250 (200)	472 (368)												
2xG...C650	400 (315)	750 (585)	355 (300)	650 (507)	315 (224)	540 (421)												
2xG...C750	450 (315)	796 (621)	400 (315)	750 (585)	315 (250)	585 (456)												

Ambient Temperature/Load and Altitude/Load – 400V AC (Frames 8...10) (Continued)

Cat. No. (see page 5)	400V AC, Power Rating at 40 °C (104 °F) (Power Rating at 50 °C [122 °F])						Derating for IP20 NEMA/UL Type 1 (Frames 8...10), IP00 NEMA/UL Type 0 (Frames 8...10), and IP54 NEMA/UL Type 12 (Frames 8...10)			
	Light Duty		Normal Duty		Heavy Duty		Ambient Temperature/Load		Altitude/Load	
	kW	Cont. Amps	kW	Cont. Amps	kW	Cont. Amps	2 kHz	4 kHz	8 kHz	12 kHz
2xG...C770	450 (355)	832 (649)	400 (355)	770 (601)	355 (300)	642 (501)				
2xG...C910	560 (425)	1040 (811)	500 (375)	910 (710)	400 (315)	750 (585)	See 2xG...C460		See 2xG...C460	
2xG...C1K0	630 (475)	1090 (850)	560 (425)	1040 (811)	500 (355)	880 (686)	See 2xG...C540		See 2xG...C540	
2xG...C1K1	710 (500)	1175 (917)	630 (475)	1090 (850)	500 (375)	910 (710)	See 2xG...C567		See 2xG...C567	
2xG...C1K2	800 (630)	1465 (1143)	710 (500)	1175 (917)	560 (425)	1040 (811)	See 2xG...C650		See 2xG...C650	
2xG...C1K4	850 (670)	1480 (1154)	800 (630)	1465 (1143)	630 (450)	1090 (850)	See 2xG...C750		See 2xG...C750	
2xG...C1K5	900 (750)	1600 (1248)	850 (670)	1480 (1154)	710 (500)	1175 (917)	See 2xG...C770		See 2xG...C770	
2xG...C1K6	1000 (710)	1715 (1338)	900 (750)	1590 (1240)	710 (600)	1325 (1034)	See 2xG...C567		See 2xG...C567	
2xG...C2K1	1400 (1000)	2330 (1817)	1250 (950)	2150 (1677)	1000 (750)	1800 (1404)	See 2xG...C770		See 2xG...C770	

Ambient Temperature/Load and Altitude/Load – 480V AC (Frames 1...7)

Cat. No. (see page 5)	480V AC Power Rating						Derating for IP20 NEMA/UL Type Open (Frames 1...5) and IP00 NEMA/UL Type Open (Frames 6 and 7) ⁽¹⁾			
	Light Duty		Normal Duty		Heavy Duty		Ambient Temperature/Load		Altitude/Load	
	Hp	Cont. Amps	Hp	Cont. Amps	Hp	Cont. Amps	2 kHz	4 kHz	8 kHz	12 kHz
20x...D8PO (Frame 1)	-	-	5.0	8.0	3.0	5.0				
20x...D011 (Frame 1)	-	-	7.5	11	5.0	8.0				

Ambient Temperature/Load and Altitude/Load – 480V AC (Frames 1...7) (Continued)

Cat. No. (see page 5)	480V AC Power Rating						Derating for IP20 NEMA/UL Type Open (Frames 1...5) and IP00 NEMA/UL Type Open (Frames 6 and 7) ⁽¹⁾	
	Light Duty		Normal Duty		Heavy Duty		Ambient Temperature/Load	
	Hp	Cont. Amps	Hp	Cont. Amps	Hp	Cont. Amps	Altitude/Load	
20x...D014 (Frame 1)	-	-	10	14	7.5	11		
20x...D014 (Frame 2)	-	-	10	14	7.5	11		
20x...D022	-	-	15	22	10	14		
20x...D027	-	-	20	27	15	22		
20x...D034	-	-	25	34	20	27		

Ambient Temperature/Load and Altitude/Load – 480V AC (Frames 1...7) (Continued)

Cat. No. (see page 5)	480V AC Power Rating						Derating for IP20 NEMA/UL Type Open (Frames 1...5) and IP00 NEMA/UL Type Open (Frames 6 and 7) ⁽¹⁾	
	Light Duty		Normal Duty		Heavy Duty		Ambient Temperature/Load	Altitude/Load
	Hp	Cont. Amps	Hp	Cont. Amps	Hp	Cont. Amps	— 2 kHz — 4 kHz — 8 kHz — 12 kHz	— 2 kHz — 4 kHz — 8 kHz — 12 kHz — 2 kHz w/Cabinet Option (21G) — 4 kHz w/Cabinet Option (21G)
20x...D040	-	-	30	40	25	34		
20x...D052	-	-	40	52	30	40		
20x...D065	-	-	50	65	40	52		
20x...D077	-	-	60	77	50	65		
20x...D096	-	-	75	96	60	77		

Ambient Temperature/Load and Altitude/Load – 480V AC (Frames 1...7) (Continued)

Cat. No. (see page 5)	480V AC Power Rating						Derating for IP20 NEMA/UL Type Open (Frames 1...5) and IP00 NEMA/UL Type Open (Frames 6 and 7) ⁽¹⁾	
	Light Duty		Normal Duty		Heavy Duty		Ambient Temperature/Load	Altitude/Load
	Hp	Cont. Amps	Hp	Cont. Amps	Hp	Cont. Amps	— 2 kHz — 4 kHz — 8 kHz — 12 kHz	— 2 kHz — 4 kHz — 8 kHz — 12 kHz — 2 kHz w/Cabinet Option (21G) — 4 kHz w/Cabinet Option (21G)
20x...D125	-	-	100	125	75	96		
20x...D156	-	-	125	156	100	125		
20x...D186	-	-	150	186	125	156		
20x...D248	-	-	200	248	150	186		
20x...D302	-	-	250	302	200	248		

Ambient Temperature/Load and Altitude/Load – 480V AC (Frames 1...7) (Continued)

Cat. No. (see page 5)	480V AC Power Rating						Derating for IP20 NEMA/UL Type Open (Frames 1...5) and IP00 NEMA/UL Type Open (Frames 6 and 7) ⁽¹⁾			
	Light Duty		Normal Duty		Heavy Duty		Ambient Temperature/Load		Altitude/Load	
	Hp	Cont. Amps	Hp	Cont. Amps	Hp	Cont. Amps	2 kHz	4 kHz	8 kHz	12 kHz
20x...D361	-	-	300	361	250	302				
20x...D415	-	-	350	415	300	361				
20x...D477	-	-	400	477	300	361				

(1) Other enclosure types follow the same derating, while not exceeding, the maximum surrounding air temperature listed in [Environmental Specifications on page 61](#).

Ambient Temperature/Load and Altitude/Load – 480V AC (Frames 8...10)

Cat. No. (see page 5)	480V AC Power Rating at 40 °C (104 °F) (Power Rating at 50 °C [122 °F])						Derating for IP20 NEMA/UL Type 1 (Frames 8...10), IP00 NEMA/UL Type 0 (Frames 8...10), and IP54 NEMA/UL Type 12 (Frames 8...10)			
	Light Duty		Normal Duty		Heavy Duty		Ambient Temperature/Load		Altitude/Load	
	Hp	Cont. Amps	Hp	Cont. Amps	Hp	Cont. Amps	2 kHz	4 kHz	8 kHz	12 kHz
2xG...D430	400 (300)	485 (378)	350 (250)	430 (335)	300 (250)	370 (289)				

Ambient Temperature/Load and Altitude/Load – 480V AC (Frames 8...10) (Continued)

Cat. No. (see page 5)	480V AC Power Rating at 40 °C (104 °F) (Power Rating at 50 °C [122 °F])						Derating for IP20 NEMA/UL Type 1 (Frames 8...10), IP00 NEMA/UL Type 0 (Frames 8...10), and IP54 NEMA/UL Type 12 (Frames 8...10)			
	Light Duty		Normal Duty		Heavy Duty		Ambient Temperature/Load		Altitude/Load	
	Hp	Cont. Amps	Hp	Cont. Amps	Hp	Cont. Amps	2 kHz	4 kHz	8 kHz	12 kHz
2xG...D485	450 (350)	545 (425)	400 (300)	485 (378)	350 (250)	414 (323)				
2xG...D545	500 (400)	590 (460)	450 (350)	545 (425)	350 (300)	454 (354)				
2xG...D617	600 (450)	710 (554)	500 (400)	617 (481)	400 (300)	485 (378)				
2xG...D710	650 (500)	765 (597)	600 (450)	710 (554)	450 (350)	545 (425)				
2xG...D740	700 (500)	800 (624)	650 (450)	740 (577)	500 (400)	617 (481)				
2xG...D800	800 (650)	960 (749)	700 (500)	800 (624)	600 (450)	710 (554)	See 2xG...D430	See 2xG...D430		
2xG...D960	900 (750)	1045 (815)	800 (650)	960 (749)	700 (500)	795 (620)	See 2xG...D485	See 2xG...D485		
2xG...D1K0	1000 (850)	1135 (885)	900 (700)	1045 (815)	750 (500)	800 (624)	See 2xG...D545	See 2xG...D545		
2xG...D1K2	1100 (900)	1365 (1065)	1000 (800)	1135 (885)	800 (600)	960 (749)	See 2xG...D617	See 2xG...D617		

Ambient Temperature/Load and Altitude/Load – 480V AC (Frames 8...10) (Continued)

Cat. No. (see page 5)	480V AC Power Rating at 40 °C (104 °F) (Power Rating at 50 °C [122 °F])						Derating for IP20 NEMA/UL Type 1 (Frames 8...10), IP00 NEMA/UL Type 0 (Frames 8...10), and IP54 NEMA/UL Type 12 (Frames 8...10)		
	Light Duty		Normal Duty		Heavy Duty		Ambient Temperature/Load		Altitude/Load
	Hp	Cont. Amps	Hp	Cont. Amps	Hp	Cont. Amps	— 2 kHz — 4 kHz — 8 kHz — 12 kHz	— 2 kHz — 4 kHz — 8 kHz — 12 kHz	
2xG...D1K3	1250 (950)	1420 (1108)	1100 (900)	1365 (1065)	900 (700)	1045 (815)	See 2xG...D710	See 2xG...D710	
2xG...D1K4	1350 (1000)	1540 (1201)	1250 (950)	1420 (1108)	1000 (750)	1135 (885)	See 2xG...D740	See 2xG...D740	
2xG...D1K5	1500 (1100)	1655 (1291)	1350 (1000)	1525 (1190)	1100 (900)	1270 (991)	See 2xG...D545	See 2xG...D545	
2xG...D2K0	2000 (1650)	2240 (1747)	1750 (1350)	2070 (1615)	1650 (1100)	1730 (1349)	See 2xG...D740	See 2xG...D740	

Ambient Temperature/Load and Altitude/Load – 600V AC (Frames 3...7)

Cat. No. (see page 5)	600V AC Power Rating						Derating for IP20 NEMA/UL Type Open (Frames 3...5), and IP00 NEMA/UL Type Open (Frames 6 and 7)		
	Light Duty		Normal Duty		Heavy Duty		Ambient Temperature/Load		Altitude/Load
	Hp	Cont. Amps	Hp	Cont. Amps	Hp	Cont. Amps	— 2 kHz — 4 kHz — 8 kHz — 12 kHz	— 2 kHz w/Cabinet Option (21G) — 4 kHz w/Cabinet Option (21G)	
20x...E017	-	-	15	17	10	11			
20x...E022	-	-	20	22	15	17			
20x...E027	-	-	25	27	20	22			
20x...E032	-	-	30	32	25	27			

Ambient Temperature/Load and Altitude/Load – 600V AC (Frames 3...7) (Continued)

Cat. No. (see page 5)	600V AC Power Rating						Derating for IP20 NEMA/UL Type Open (Frames 3...5), and IP00 NEMA/UL Type Open (Frames 6 and 7)			
	Light Duty		Normal Duty		Heavy Duty		Ambient Temperature/Load		Altitude/Load	
	Hp	Cont. Amps	Hp	Cont. Amps	Hp	Cont. Amps				
20x...E041	-	-	40	41	30	32				
20x...E052	-	-	50	52	40	41				
20x...E099	-	-	100	99	75	77				
20x...E125	-	-	125	125	100	99				
20x...E144	-	-	150	144	125	125				

Ambient Temperature/Load and Altitude/Load – 600V AC (Frames 3...7) (Continued)

Cat. No. (see page 5)	600V AC Power Rating						Derating for IP20 NEMA/UL Type Open (Frames 3...5), and IP00 NEMA/UL Type Open (Frames 6 and 7)			
	Light Duty		Normal Duty		Heavy Duty		Ambient Temperature/Load		Altitude/Load	
	Hp	Cont. Amps	Hp	Cont. Amps	Hp	Cont. Amps				
20x...E192	-	-	200	192	150	144				
20x...E242	-	-	250	242	200	192				
20x...E289	-	-	300	289	250	242				

Ambient Temperature/Load and Altitude/Load – 600V AC (Frames 8...10)

Cat. No. (see page 5)	600V AC Power Rating at 40 °C (104 °F) (Power Rating at 50 °C [122 °F])						Derating for IP20 NEMA/UL Type 1 (Frames 8...10), IP00 NEMA/UL Type 0 (Frames 8...10), and IP54 NEMA/UL Type 12 (Frames 8...10)			
	Light Duty		Normal Duty		Heavy Duty		Ambient Temperature/Load		Altitude/Load	
	Hp	Cont. Amps	Hp	Cont. Amps	Hp	Cont. Amps				
2xG...E295	350 (250)	355 (277)	300 (200)	295 (230)	250 (200)	272 (212)				

Ambient Temperature/Load and Altitude/Load – 600V AC (Frames 8...10) (Continued)

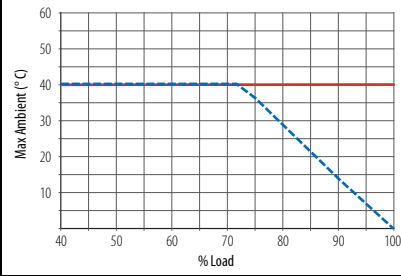
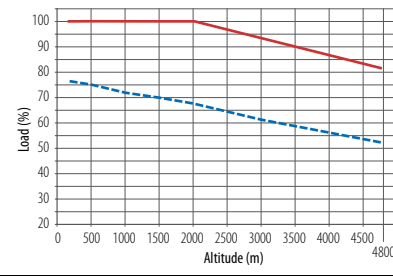
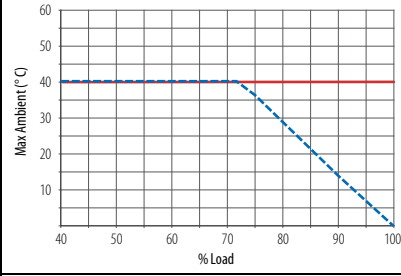
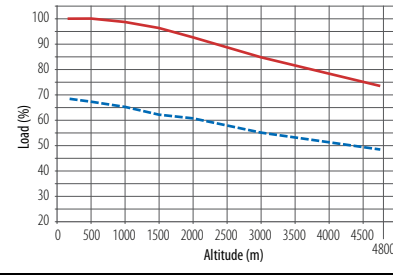
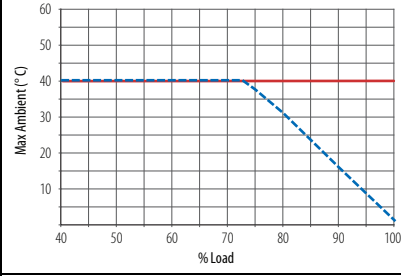
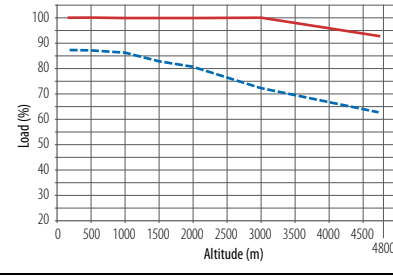
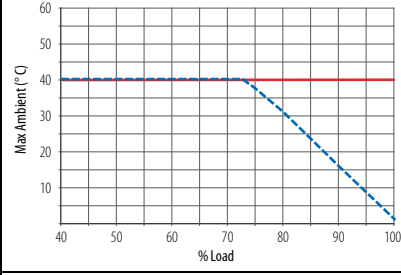
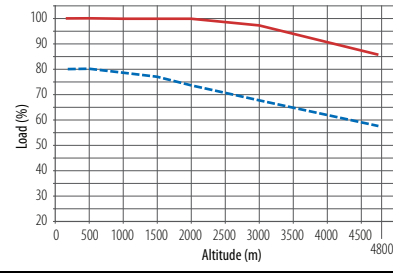
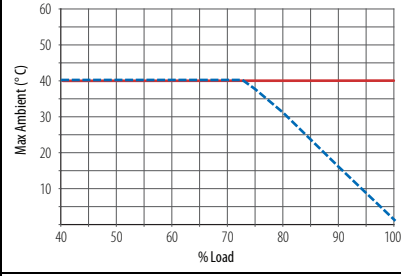
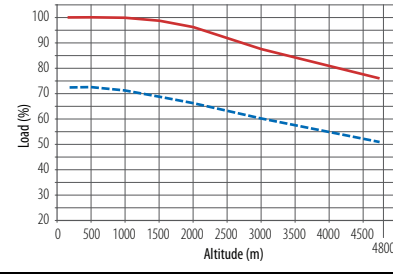
Cat. No. (see page 5)	600V AC Power Rating at 40 °C (104 °F) (Power Rating at 50 °C [122 °F])						Derating for IP20 NEMA/UL Type 1 (Frames 8...10), IP00 NEMA/UL Type 0 (Frames 8...10), and IP54 NEMA/UL Type 12 (Frames 8...10)	
	Light Duty		Normal Duty		Heavy Duty		Ambient Temperature/Load	
	Hp	Cont. Amps	Hp	Cont. Amps	Hp	Cont. Amps	Altitude/Load	
2xG...E355	400 (300)	395 (308)	350 (250)	355 (277)	300 (200)	295 (230)		
2xG...E395	450 (300)	435 (339)	400 (300)	395 (308)	350 (250)	329 (257)		
2xG...E435	500 (350)	460 (359)	450 (300)	435 (339)	350 (250)	355 (277)		
2xG...E460	500 (400)	510 (398)	500 (350)	460 (359)	400 (300)	395 (308)		
2xG...E510	550 (400)	545 (425)	500 (400)	510 (398)	450 (300)	425 (332)		
2xG...E595	700 (500)	690 (538)	600 (450)	595 (464)	500 (400)	510 (398)	See 2xG...E295	See 2xG...E295
2xG...E630	800 (550)	760 (593)	700 (500)	630 (491)	600 (450)	595 (464)	See 2xG...E395	See 2xG...E355
2xG...E760	900 (650)	835 (651)	800 (550)	760 (593)	700 (500)	630 (491)	See 2xG...E395	See 2xG...E395
2xG...E825	950 (700)	900 (702)	900 (600)	825 (644)	750 (550)	700 (546)	See 2xG...E435	See 2xG...E435

Ambient Temperature/Load and Altitude/Load – 600V AC (Frames 8...10) (Continued)

Cat. No. (see page 5)	600V AC Power Rating at 40 °C (104 °F) (Power Rating at 50 °C [122 °F])						Derating for IP20 NEMA/UL Type 1 (Frames 8...10), IP00 NEMA/UL Type 0 (Frames 8...10), and IP54 NEMA/UL Type 12 (Frames 8...10)			
	Light Duty		Normal Duty		Heavy Duty		Ambient Temperature/Load		Altitude/Load	
	Hp	Cont. Amps	Hp	Cont. Amps	Hp	Cont. Amps	2 kHz	4 kHz	8 kHz	12 kHz
2xG...E900	1000 (750)	980 (764)	950 (700)	900 (702)	800 (600)	760 (593)	See 2xG...E460		See 2xG...E460	
2xG...E980	1100 (800)	1045 (815)	1000 (750)	980 (764)	900 (625)	815 (636)	See 2xG...E510		See 2xG...E510	
2xG...E1K1	1200 (950)	1220 (952)	1100 (850)	1110 (866)	1000 (700)	920 (718)	See 2xG...E395		See 2xG...E395	
2xG...E1K4	1500 (1100)	1530 (1193)	1400 (1000)	1430 (1115)	1250 (900)	1190 (928)	See 2xG...E510		See 2xG...E510	

Ambient Temperature/Load and Altitude/Load – 690V AC (Frames 6 and 7)

Cat. No. (see page 5)	690V AC Power Rating						Derating for IP00 NEMA/UL Type Open (Frames 6 and 7)			
	Light Duty		Normal Duty		Heavy Duty		Ambient Temperature/Load		Altitude/Load	
	kW	Cont. Amps	kW	Cont. Amps	kW	Cont. Amps	2 kHz	4 kHz	8 kHz	12 kHz
2xG...F030	-	-	22	30	18.5	23				
2xG...F034	-	-	30	34	22	30				
2xG...F046	-	-	37	46	30	34				
2xG...F050	-	-	45	50	37	46				

Ambient Temperature/Load and Altitude/Load – 690V AC (Frames 6 and 7) (Continued)

Cat. No. (see page 5)	690V AC Power Rating				Derating for IP00 NEMA/UL Type Open (Frames 6 and 7)		Ambient Temperature/Load		Altitude/Load	
	Light Duty		Normal Duty		Heavy Duty					
	kW	Cont. Amps	kW	Cont. Amps	kW	Cont. Amps				
2xG...F061	-	-	55	61	45	50				
2xG...F082	-	-	75	82	55	61				
2xG...F098	-	-	90	98	75	82				
2xG...F119	-	-	110	119	90	98				
2xG...F142	-	-	132	142	110	119				

Ambient Temperature/Load and Altitude/Load – 690V AC (Frames 6 and 7) (Continued)

Cat. No. (see page 5)	690V AC Power Rating						Derating for IP00 NEMA/UL Type Open (Frames 6 and 7)	
	Light Duty		Normal Duty		Heavy Duty		Ambient Temperature/Load	Altitude/Load
	kW	Cont. Amps	kW	Cont. Amps	kW	Cont. Amps		
2xG...F171	-	-	160	171	132	142		
2xG...F212	-	-	200	212	160	171		
2xG...F263	-	-	250	263	200	212		

Ambient Temperature/Load and Altitude/Load – 690V AC (Frames 8...10)

Cat. No. (see page 5)	690V AC Power Rating at 40 °C (104 °F) (Power Rating at 50 °C [122 °F])						Derating for IP20 NEMA/UL Type 1 (Frames 8...10), IP00 NEMA/UL Type 0 (Frames 8...10), and IP54 NEMA/UL Type 12 (Frames 8...10)	
	Light Duty		Normal Duty		Heavy Duty		Ambient Temperature/Load	Altitude/Load
	kW	Cont. Amps	kW	Cont. Amps	kW	Cont. Amps		
2xG...F265	315 (250)	330 (257)	250 (200)	265 (207)	200 (160)	215 (168)		
2xG...F330	355 (250)	370 (289)	315 (224)	330 (257)	250 (200)	285 (207)		

Ambient Temperature/Load and Altitude/Load – 690V AC (Frames 8...10) (Continued)

Cat. No. (see page 5)	690V AC Power Rating at 40 °C (104 °F) (Power Rating at 50 °C [122 °F])						Derating for IP20 NEMA/UL Type 1 (Frames 8...10), IP00 NEMA/UL Type 0 (Frames 8...10), and IP54 NEMA/UL Type 12 (Frames 8...10)	
	Light Duty		Normal Duty		Heavy Duty		Ambient Temperature/Load	
	kW	Cont. Amps	kW	Cont. Amps	kW	Cont. Amps	Altitude/Load	
2xG...F370	400 (315)	410 (320)	355 (250)	370 (289)	300 (224)	308 (240)		
2xG...F415	450 (355)	460 (359)	400 (315)	415 (324)	355 (250)	370 (289)		
2xG...F460	500 (375)	500 (390)	450 (350)	460 (359)	375 (300)	375 (293)		
2xG...F500	530 (400)	530 (413)	500 (400)	500 (390)	400 (315)	413 (322)		
2xG...F590	630 (500)	650 (507)	560 (450)	590 (460)	450 (355)	460 (359)	See 2xG...F265	See 2xG...F265
2xG...F650	710 (530)	710 (554)	630 (500)	650 (507)	500 (375)	500 (390)	See 2xG...F330	See 2xG...F330
2xG...F710	800 (560)	790 (616)	710 (530)	710 (554)	560 (450)	590 (460)	See 2xG...F370	See 2xG...F370
2xG...F765	850 (630)	860 (671)	750 (600)	765 (597)	630 (500)	650 (507)	See 2xG...F415	See 2xG...F415
2xG...F795	900 (710)	960 (749)	800 (630)	795 (620)	710 (600)	750 (585)	See 2xG...F460	See 2xG...F460
2xG...F960	1000 (800)	1020 (796)	900 (750)	960 (749)	800 (600)	795 (620)	See 2xG...F500	See 2xG...F500
2xG...F1K0	1100 (900)	1150 (897)	1000 (750)	1040 (811)	900 (670)	865 (675)	See 2xG...F370	See 2xG...F370
2xG...F1K4	1500 (1120)	1485 (1158)	1400 (1000)	1400 (1092)	1120 (900)	1160 (905)	See 2xG...F500	See 2xG...F500

Minimum Dynamic Brake Resistance

The tables in this section show the minimum dynamic brake resistance when you use the internal dynamic braking transistor.

Brake Resistance for 208/240V Drives

Frame	240V				208V			
	ND Hp	Catalog Code	Min Resistance	Max DB Current	ND kW	Catalog Code	Min Resistance	Max DB Current
1	0.5	B2P2	39.5	10	0.37	B2P2	39.5	10
	1.0	B4P2	39.5	10	0.75	B4P2	39.5	10
	2.0	B6P8	26.3	15	1.5	B6P8	26.3	15
	3.0	B9P6	15.8	25	2.2	B9P6	15.8	25
	5.0	B015	15.8	25	4	B015	15.8	25
2	0.5	B2P2	15.8	25	0.37	B2P2	15.8	25
	1.0	B4P2	15.8	25	0.75	B4P2	15.8	25
	2.0	B6P8	15.8	25	1.5	B6P8	15.8	25
	3.0	B9P6	15.8	25	2.2	B9P6	15.8	25
	5.0	B015	11.29	35	4	B015	11.29	35
	7.5	B022	11.29	35	5.5	B022	11.29	35
3	10	B028	15.8	25	7.5	B028	15.8	25
	15	B042	8.3	47.6	11	B042	8.3	47.6
4	20	B054	7.9	50	15	B054	7.9	50
5	25	B070	3.95	100	18.5	B070	3.95	100
	30	B080	3.95	100	22	B080	3.95	100
6	30 ⁽¹⁾	B080 ⁽¹⁾	1.65	239.4	22 ⁽¹⁾	B080 ⁽¹⁾	1.65	239.4
	40	B104	1.65	239.4	30	B104	1.65	239.4
	50	B130	1.65	239.4	37	B130	1.65	239.4
	60	B154	1.65	239.4	45	B154	1.65	239.4
	75	B192	1.65	239.4	55	B192	1.65	239.4
	100	B260	1.65	239.4	66	B260	1.65	239.4
7	100 ⁽¹⁾	B260 ⁽¹⁾	1.2	329	66 ⁽¹⁾	B260 ⁽¹⁾	1.2	329
	125	B312	1.2	329	90	B312	1.2	329
	150	B360	0.82	478.8	110	B360	0.82	478.8
	200	B477	0.82	478.8	132	B477	0.82	478.8

(1) IP54, NEMA/UL Type 12 (enclosure code 6).

Brake Resistance for 400/480V Drives

Frame	480V				400V			
	ND Hp	Catalog Code	Min Resistance	Max DB Current	ND kW	Catalog Code	Min Resistance	Max DB Current
1	1.0	D2P1	79.0	10	0.75	C2P1	79.0	10
	2.0	D3P4	79.0	10	1.5	C3P5	79.0	10
	3.0	D5P0	79.0	10	2.2	C5P0	79.0	10
	5.0	D8P0	52.7	15	4	C8P7	52.7	15
	7.5	D011	31.6	25	5.5	C011	31.6	25
	10	D014	31.6	25	7.5	C015	31.6	25
2	1.0	D2P1	31.6	25	0.75	C2P1	31.6	25
	2.0	D3P4	31.6	25	1.5	C3P5	31.6	25
	3.0	D5P0	31.6	25	2.2	C5P0	31.6	25
	5.0	D8P0	31.6	25	4	C8P0	31.6	25
	7.5	D011	31.6	25	5.5	C011	31.6	25
	10	D014	31.6	25	7.5	C015	31.6	25
	15	D022	22.6	34.9	11	C022	22.6	34.9
3	20	D027	31.6	25	15	C030	31.6	25
	25	D034	31.6	25	18.5	C037	31.6	25
	30	D040	16.6	47.6	22	C043	16.6	47.6

Brake Resistance for 400/480V Drives (Continued)

Frame	480V				400V			
	ND Hp	Catalog Code	Min Resistance	Max DB Current	ND kW	Catalog Code	Min Resistance	Max DB Current
4	40	D052	15.8	50	30	C060	15.8	50
	50	D065	15.8	50	37	C072	15.8	50
5	50 ⁽¹⁾	D065 ⁽¹⁾	7.9	100	37 ⁽¹⁾	C075 ⁽¹⁾	7.9	100
	60	D077	7.9	100	45	C085	7.9	100
	75	D096	7.9	100	55	C104	7.9	100
6	75 ⁽¹⁾	D096 ⁽¹⁾	3.3	239.4	55 ⁽¹⁾	C104 ⁽¹⁾	3.3	239.4
	100	D125	3.3	239.4	75	C140	3.3	239.4
	125	D156	3.3	239.4	90	C170	3.3	239.4
	150	D186	3.3	239.4	110	C205	3.3	239.4
	200	D248	3.3	239.4	132	C260	3.3	239.4
7	200 ⁽¹⁾	D248 ⁽¹⁾	2.4	329	132 ⁽¹⁾	C260 ⁽¹⁾	2.4	329
	250	D302	2.4	329	160	C302	2.4	329
	300	D361	2.4	329	200	C367	2.4	329
	350	D415	1.65	478.8	250	C456	1.65	478.8
	400	D477	1.65	478.8	270	C477	1.65	478.8

(1) IP54, NEMA/UL Type 12 (enclosure code G).

Brake Resistance for 600V Drives (Frames 3...5)

Frame	600V			
	ND Hp	Catalog Code	Min Resistance	Max DB Current
3	1.0	E1P7	92	11
	2.0	E2P7	92	11
	3.0	E3P9	92	11
	5.0	E6P1	32	30
	7.5	E9P0	32	30
	10	E011	32	30
	15	E017	32	30
	20	E022	32	30
4	25	E027	32	30
	30	E032	32	30
5	40	E041	13.5	71
	50	E052	13.5	71

Brake Resistance for 600/690V Drives (Frames 6 and 7)

Frame	600V				690V			
	ND Hp	Catalog Code	Min Resistance	Max DB Current	ND kW	Catalog Code	Min Resistance	Max DB Current
6	10	E012	14.4	76.4	7.5	F012	14.4	76.4
	15	E018	14.4	76.4	11	F015	14.4	76.4
	20	E023	14.4	76.4	15	F020	14.4	76.4
	20	E024	14.4	76.4	18.5	F023	14.4	76.4
	25	E028	14.4	76.4	22	F030	14.4	76.4
	30	E033	14.4	76.4	30	F034	14.4	76.4
	40	E042	14.4	76.4	37	F046	14.4	76.4
	50	E053	14.4	76.4	45	F050	14.4	76.4
	60	E063	5.5	200	55	F061	5.5	200
	75	E077	5.5	200	75	F082	5.5	200
	100	E099	5.5	200	90	F098	5.5	200
	125	E125	5.5	200	110	F119	5.5	200
	150	E144	5.5	200	132	F142	5.5	200
	7	200	E192	3.8	289	160	F171	3.8
250		E242	3.8	289	200	F212	3.8	289
300		E289	3.2	344	250	F263	3.2	344

Fuse and Circuit Breaker Ratings

The tables in this section provide recommended AC line input fuse and circuit breaker information. See [Fusing on page 100](#) and [Circuit Breakers on page 100](#) for UL and IEC requirements. The size recommendations are based on 40 °C (104 °F) and the U.S. NEC. Other country, state, or local codes can require different ratings. DC link fuse recommendations for DC input drives are also provided. In addition, Frame 8 and larger drives include AC line fuses (with blown fuse indicators) to provide drive short circuit protection.

Input Device Requirements

Frame s	Enclosure Catalog Code	Enclosure Type	Installation Type	UL Certification Required	UL Certification Not Required
1	R	IP20 NEMA/UL Open Type	Installed in a ventilated or non-ventilated cabinet.	All devices that are listed on pages 101 , 103 , 105 and 109 are acceptable. When installed in a ventilated cabinet, time delay fuses, circuit breakers, and 140M/MT Motor Protection Circuit Breakers (MPCBs) that are rated for use as self-protected combination motor controller must meet or exceed the listed minimum enclosure volume on pages 105 and 109 .	All devices that are listed on pages 101 through 117 are acceptable.
			Installed outside of cabinet by using NEMA Type 1 kit or in a ventilated cabinet.	Only non-time delay fuses that are listed on pages 101 , 103 , 105 and 109 , excluding maximum value, are acceptable.	
2...5	N	IP20 NEMA/UL Open Type	Installed in a ventilated or non-ventilated cabinet. Heat sink is inside or outside of cabinet.	All devices that are listed on pages 101 , 103 , 105 , 109 , and 113 are acceptable. When installed in a ventilated cabinet, time delay fuses, circuit breakers, and 140M/MT MPCBs must meet or exceed the listed minimum enclosure volume on pages 101 , 103 , 105 , 109 , and 113 .	
	F	Flange			
	N	IP20 NEMA/UL Open Type	Installed outside of cabinet by using NEMA Type 1 kit or in a ventilated cabinet.	208V AC/281V DC or 240V AC/324V DC drives. Only non-time delay fuses that are listed on pages 101 and 103 , excluding maximum value, are acceptable. 400V AC/540V DC or 480V AC/650V DC drives. Only non-time delay fuses that are listed on pages 105 and 109 , excluding maximum value, are acceptable. 600V AC/810V DC drives. Only non-time delay fuses that are listed on page 113 are acceptable, with maximum value of 40 A (Frame 3), 60 A (Frame 4), and 100 A (Frame 5).	
	F	Flange			
	G	IP54 NEMA/UL Type 12	Installed inside or outside of any cabinet.	All devices that are listed on pages 101 , 103 , 105 , 109 , and 113 are acceptable.	
6 and 7	N	IP00 NEMA/UL Open Type	Installed in any cabinet. Heat sink is inside or outside of cabinet.	208V AC/281V DC or 240V AC/324V DC drives. Only non-time delay fuses that are listed on pages 101 and 103 , excluding maximum value, are acceptable. 400V AC/540V DC or 480V AC/650V DC drives. All devices that are listed on pages 105 and 109 are acceptable. 600V AC/810V DC drives. Only time delay and non-time delay fuses that are listed on page 113 are acceptable.	
			Installed outside of cabinet by using NEMA Type 1 kit.		
	G	IP54 NEMA/UL Type 12	Installed inside or outside of any cabinet.	All devices that are listed on pages 101 , 103 , 105 , 109 , and 113 are acceptable.	
8...10	B, L, P, W	IP20 NEMA/UL Type 1	Installed inside of any cabinet.	All devices that are listed on pages 107 , 111 , and 115 are acceptable.	
	J, K, Y	IP54 NEMA 12	Installed inside or outside of any cabinet.	All devices that are listed on pages 107 , 111 , and 115 are acceptable.	

IMPORTANT

For maximum protection of the drive and its internal components, we recommend the use of semiconductor fuses to other methods of circuit protection. Semiconductor fuses reduce the risk of drive damage from power quality events and improves machine and process utilization.

Fusing

The recommended fuse types are listed here. If available current ratings do not match the ratings that are listed in these tables, choose the next higher fuse rating.

- IEC – BS88 (British Standard) Parts 1 & 2, EN60269-1, Parts 1 & 2, type gG or equivalent must be used.
Typical designations include, but is not limited to the following; Parts 1 & 2: AC, AD, BC, BD, CD, DD, ED, EFS, EF, FF, FG, GF, GG, GH.
- UL – UL Class CC, T, RK1, J, or L must be used.

Circuit Breakers

The non-fuse listings in the following tables include inverse time circuit breakers, instantaneous trip circuit breakers (motor circuit protectors), and 140M/MT Motor Protection Circuit Breakers (MPCBs) that are rated for use as self-protected combination motor controller. If one of these methods are chosen for protection, the following requirements apply:

- IEC – Both types of circuit breakers and 140M/MT self-protected combination motor controllers are acceptable for IEC installations.
- UL – Only inverse time circuit breakers and the specified 140M/MT self-protected combination motor controllers are acceptable for UL installations.

208V AC and 281V DC Input Protection Devices - Wall Mount Frames 1...7

Applied Rating ⁽¹⁾	Frame	Cont. Output [A]		Drive Sized for Normal Duty		Drive Sized for Heavy Duty		Input Quantities		AC Input Protection Devices							DC Input Protection ⁽¹⁵⁾					
		Cont. Output [A]	[A]	Cat. No.	Output Overload [A]	60 s	3 s	Cat. No.	Output Overload [A]	60 s	3 s	[kVA]	[A]	Continuous AC Input	Circuit Breaker [A] ⁽⁶⁾	Non-time Delay Fuse	Motor Circuit Protector [A] ⁽⁶⁾	140M/MT MPCB with Adjustable Current Range ⁽⁹⁾⁽¹⁰⁾	Min Enclosure Volume (in. ³) ⁽¹⁴⁾	Input Quantities	Continuous DC Input	Non-time Delay Fuse
208V AC Input																						
0.37 kW	1	2.5	20x...B2P2	2.75	3.75	20x...B4P2	5.28	7.2	0.73	2.0	3	6	3	10	15	3840	3	140M-xxx-B25 140MT-xxx-B25 ⁽¹²⁾	7269	2.4	JKS-6	
0.75 kW	1	4.8	20x...B4P2	5.28	7.2	20x...B6P8	8.58	11.7	1.4	3.9	6	10	6	15	20	3840	7	140M-xxx-B63 140MT-xxx-B63 ⁽¹²⁾	7269	4.5	JKS-10	
1.5 kW	1	7.8	20x...B6P8	8.58	11.7	20x...B9P6	12.1	16.5	2.5	7.0	10	15	10	25	30	3840	15	140M-xxx-C10 140MT-xxx-C10 ⁽¹²⁾	7269	8.2	HSJ-15	
2.2 kW	1	11	20x...B9P6	12.1	16.5	20x...B015	16.8	22.95	3.6	9.9	15	20	15	35	40	3840	15	140M-xxx-C16 140MT-xxx-C16 ⁽¹²⁾	7269	11.6	HSJ-20	
4 kW	1	15.3	20x...B015	16.83	22.95	20x...B022 ⁽³⁾	24.2	33	5.2	14.3	20	30	20	50	60	3840	20	140M-xxx-C20 140MT-xxx-C20 ⁽¹²⁾	7269	16.7	HSJ-30	
0.37 kW	2	2.5	20x...B2P2	3.75	4.5	20x...B2P2	3.75	4.5	0.7	2.0	3	6	3	10	15	3840	3	140M-xxx-B25 140MT-xxx-B25 ⁽¹²⁾	9086	2.4	JKS-6	
0.75 kW	2	4.8	20x...B4P2	7.2	8.64	20x...B4P2	7.2	8.64	1.4	3.9	6	10	6	15	20	3840	7	140M-xxx-B63 140MT-xxx-B63 ⁽¹²⁾	9086	4.5	JKS-10	
1.5 kW	2	7.8	20x...B6P8	11.7	14.04	20x...B6P8	11.7	14.04	2.5	7.0	10	15	10	25	30	3840	15	140M-xxx-C10 140MT-xxx-C10 ⁽¹²⁾	9086	8.2	HSJ-15	
2.2 kW	2	11	20x...B9P6	16.5	19.8	20x...B9P6	16.5	19.8	3.6	9.9	15	20	15	35	40	3840	15	140M-xxx-C16 140MT-xxx-C16 ⁽¹²⁾	9086	11.6	HSJ-20	
4 kW	2	17.5	20x...B015	19.25	26.25	20x...B022 ⁽³⁾	24.2	33	5.9	16.4	20	35	20	60	70	3840	20	140M-xxx-C20 140MT-xxx-C20 ⁽¹²⁾	9086	19.1	HSJ-30	
5.5 kW	2	22	20x...B022	24.2	33	20x...B028 ⁽³⁾	35.4	48.3	7.5	20.8	30	45	30	70	80	3840	30	140M-xxx-C25 140MT-xxx-C25 ⁽¹³⁾	9086	24.3	HSJ-45	
7.5 kW	3	32.2	20x...B028	35.42	48.3	20x...B042	48.3	64.5	11.1	30.8	40	60	40	100	125	4800	50	140M-F8E-C32	9086	36.0	HSJ-60	
11 kW	3	43	20x...B042	47.3	64.5	20x...B054 ⁽³⁾	64.5	90	14.8	41.2	60	80	60	150	150	4800	60	140M-F8E-C45	9086	48.1	HSJ-90	
15 kW	4	60	20x...B054	66	90	20x...B070 ⁽³⁾	90	117.3	20.7	57.4	80	125	80	200	225	4800	100			67.1	HSJ-100	
18.5 kW	5	78.2	20x...B070	86.02	117.3	20x...B080	117.3	140.8	27.0	74.9	90	150	90	250	300	7200	100			87.5	HSJ-150	
22 kW	5 ⁽²⁾	92	20x...B080	101.2	138	20x...B104 ⁽³⁾	138	180	31.7	88.1	110	175	110	300	350	7200	150			102.9	HSJ-200	
30 kW	6	120	20x...B104	132	180	20x...B130	180	225	42.4	117.6	150	250	150	400	350		150			137.4	HSJ-225	
37 kW	6	150	20x...B130	165	225	20x...B154	225	270	52.9	147.0	200	300	200	500	450		250			171.7	HSJ-300	
45 kW	6	177	20x...B154	194.7	265.5	20x...B192	265.5	331.5	62.5	173.4	225	350	225	600	500		250			202.6	HSJ-350	
281V DC Input																						

208V AC and 281V DC Input Protection Devices – Wall Mount Frames 1...7 (Continued)

Applied Rating ⁽¹⁾	Frame	Cont. Output [A]		Drive Sized for Normal Duty		Drive Sized for Heavy Duty		Input Quantities		AC Input Protection Devices						Input Quantities		DC Input Protection ⁽¹⁵⁾		
		60 s	3 s	Cat. No.	Output Overload [A]	Cat. No.	Output Overload [A]	60 s	3 s	[kVA]	[A]	Continuous AC Input	Non-time Delay Fuse	Dual Element Time Delay Fuse	Circuit Breaker [A] ⁽⁹⁾	Circuit Breaker, Dual Element Time Delay Fuse	Motor Circuit Protector [A] ⁽¹⁰⁾		140M/MT MPCB with Adjustable Current Range ⁽⁹⁾⁽¹⁰⁾	Continuous DC Input
55 kW	6	221	20x...B192	243.1	331.5	20x...B260	331.5	390	78.0	216.5	300	400	300	650	600	400	400	253.0	HSJ-400	
66 kW	6 ⁽²⁾	260	20x...B260	286	390	20x...B312 ⁽³⁾	394	538.5	91.87	254.7	350	500	350	750	700	400		297.7	HSJ-400	
90 kW	7	359	20x...B312	394.9	538.5	20x...B360	538.5	646.2	126.7	351.7	500	700	500	1000	1000	600		411.0	Bussmann 470MM612	
110 kW	7	414	20x...B360	455.4	621			7.2	146.1	405.6	600	800	600	1200	1200	600		474.0	Bussmann 470MM613	
132 kW	7	477	20x...B477	524.7	715.5			11.7	168.4	467.3	600	900	600	1400	1200	600		546.1	Bussmann 470MM613	

(1) 'Applied Rating' refers to the motor that will be connected to the drive. For example, a 'C022' drive can be used in Normal Duty mode on a 7.5 kW motor, a 'C015' drive can be used in Heavy-duty mode on a 5.5 kW motor with the same ratings as a 'C011'. The drive can be programmed for either mode. Wiring and fuses can be sized based on the programmed mode. For any given drive catalog number, Normal Duty mode provides higher continuous current but smaller overload current regarding Heavy-duty mode. See parameter 306 [Duty Rating].

(2) For IP66 (NEMA 7UL Type 4X/72) enclosures, this drive increases from the frame size listed to the next higher frame size. For example, if this drive is listed as Frame 4, then for all IP ratings other than IP66, it is a Frame 4 and for the IP66 rating, it increases to Frame 5. See table [Fl on page 5](#) for frame/rating cross reference.

(3) This drive is the next larger frame size.

(4) Minimum protection device size is the lowest rated device that supplies maximum protection without nuisance tripping.

(5) Maximum protection device size is the highest rated device that supplies drive protection. For US NEC, minimum size is 125% of motor F.L.A. Ratings that are shown are maximum.

(6) Circuit Breaker – inverse time breaker. For US NEC, minimum size is 125% of motor F.L.A. Ratings that are shown are maximum.

(7) When using a circuit breaker or time-delay fuse with a drive installed in a ventilated enclosure, the enclosure volume must be greater than or equal to the minimum volume specified in this column. Application-specific thermal considerations can require a larger enclosure.

(8) Motor Protection Circuit Breaker – instantaneous trip circuit breaker. For US NEC, minimum size is 125% of motor F.L.A. Ratings that are shown are maximum.

(9) Bulletin 140M/MT devices with adjustable current range must have the current trip set to the minimum range that the device does not trip.

(10) Manual Self-Protected (Type E) Combination Motor Controller. UL Listed for 208V Wye or Delta, 240V Wye or Delta, 480V Y/277 or 600V Y/347. Not UL Listed for use on 480V or 600V Delta/Delta, corner ground, or high-resistance ground systems.

(11) The AC ratings of Bulletin 140M/MT devices can vary. See publication [140-ID005](#) or [140M-ID002](#).

(12) Bulletin 140MT devices must be Frame C (C3E) or Frame D (D9E).

(13) Bulletin 140MT Devices must be Frame D (D9E).

(14) When using a Manual Self-Protected (Type E) Combination Motor Controller, the drive must be installed in a ventilated or non-ventilated enclosure with the minimum volume that is specified in this column. Application-specific thermal considerations can require a larger enclosure.

(15) See Fuse Certification and Test Data in PowerFlex AC Drives in Common Bus Configurations Application Guidelines, publication [DRIVES-A1002](#), for fuse self-certification and test data for Bussmann 170M and JKS fuses recommended for the DC bus fusing.

240V AC and 324V DC Input Protection Devices – Wall Mount Frames 1...7

Applied Rating (1)	Frame	Drive Sized for Normal Duty		Drive Sized for Heavy Duty		Input Quantities		AC Input Protection Devices								DC Input Protection (15)				
		Cont. Output [A]		Output Overload [A]		Output Overload [A]		Continuous AC Input [A]	[kVA]	[A]	Circuit Breaker [A] (6)				Motor Circuit Protector [A] (8)				Continuous DC Input	Non-time Delay Fuse
		Cat. No.	60 s	3 s	Cat. No.	60 s	3 s				Min (4)	Max (5)	Min Enclosure Volume (in.³) (7)	Max (5)	Min Enclosure Volume (in.³) (7)	Min Enclosure Volume (in.³) (7)	140M/MT MPCB with Adjustable Current Range (9)(10)	Cat. No. (11)		
240V AC Input																				
0.5 Hp	1	2.2	20x...B2P2	2.42	3.3	4.62	20x...B4P2	6.3	0.71	1.7	3	6	3	10	15	3840	3	140M-xxx-B25 140MT-xxx-B25 (12)	7269	JKS-6
1 Hp	1	4.2	20x...B4P2	4.62	6.3	7.48	20x...B6P8	10.2	1.36	3.3	6	10	6	15	20	3840	7	140M-xxx-B63 140MT-xxx-B63 (12)	7269	JKS-10
2 Hp	1	6.8	20x...B6P8	7.48	10.2	10.56	20x...B9P6	14.4	2.44	5.9	10	15	10	25	30	3840	15	140M-xxx-C10 140MT-xxx-C10 (12)	7269	HSJ-15
3 Hp	1	9.6	20x...B9P6	10.56	14.4	16.83	20x...B015	16.83	3.45	8.3	15	20	15	35	40	3840	15	140M-xxx-C16 140MT-xxx-C16 (12)	7269	HSJ-20
5 Hp	1	15.3	20x...B015	16.83	22.95	24.2	20x...B022 (B)	24.2	5.70	13.7	20	30	20	50	60	3840	20	140M-xxx-C20 140MT-xxx-C20 (12)	7269	HSJ-30
0.5 Hp	2	2.2	20x...B2P2	3.3	3.96	3.3	20x...B2P2	3.3	0.71	1.7	3	6	3	10	15	3840	3	140M-xxx-B25 140MT-xxx-B25 (12)	9086	JKS-6
1 Hp	2	4.2	20x...B4P2	6.3	7.56	6.3	20x...B4P2	6.3	1.36	3.3	6	10	6	15	20	3840	7	140M-xxx-B63 140MT-xxx-B63 (12)	9086	JKS-10
2 Hp	2	6.8	20x...B6P8	10.2	12.24	10.2	20x...B6P8	10.2	2.44	5.9	10	15	10	25	30	3840	15	140M-xxx-C10 140MT-xxx-C10 (12)	9086	HSJ-15
3 Hp	2	9.6	20x...B9P6	14.4	17.28	14.4	20x...B9P6	14.4	3.45	8.3	15	20	15	35	40	3840	15	140M-xxx-C16 140MT-xxx-C16 (12)	9086	HSJ-20
5 Hp	2	15.3	20x...B015	16.83	22.95	24.2	20x...B022	24.2	5.70	13.7	20	30	20	50	70	3840	20	140M-xxx-C20 140MT-xxx-C20 (12)	9086	HSJ-30
7.5 Hp	2	22	20x...B022	24.2	33	33	20x...B028 (B)	33	8.29	19.9	30	45	30	70	80	3840	30	140M-xxx-C25 140MT-xxx-C25 (13)	9086	HSJ-45
10 Hp	3	28	20x...B028	30.8	42	46.2	20x...B042	46.2	10.68	25.7	40	60	40	100	125	4800	50	140M-FBE-C32	9086	HSJ-60
15 Hp	3	42	20x...B042	46.2	63	63	20x...B054 (B)	63	16.02	38.5	60	80	60	150	150	4800	60	140M-FBE-C45	9086	HSJ-90
20 Hp	4	54	20x...B054	59.4	81	81	20x...B070 (B)	81	20.59	49.5	80	100	80	175	225	4800	100			HSJ-100
25 Hp	5	70	20x...B070	77	105	105	20x...B080	105	26.69	64.2	90	150	90	225	300	7200	100			HSJ-150
30 Hp	5(2)	80	20x...B080	88	120	120	20x...B104 (B)	120	30.50	73.4	100	175	100	300	350	7200	150			HSJ-200
40 Hp	6	104	20x...B104	114.4	156	156	20x...B130	156	40.59	97.6	150	200	150	350	350		150			HSJ-225
50 Hp	6	130	20x...B130	143	195	195	20x...B154	195	50.74	122.1	175	250	200	450	450		250			HSJ-300
60 Hp	6	154	20x...B154	169.4	231	231	20x...B192	231	60.10	144.6	225	300	225	500	500		250			HSJ-350
75 Hp	6	192	20x...B192	211.2	288	288	20x...B260	288	74.93	180.3	250	350	250	600	600		400			HSJ-400
100 Hp	6(2)	260	20x...B260	286	390	390	20x...B312 (B)	390	101.47	244.11	350	500	350	750	700		400			HSJ-400
324V DC Input																				
2.0																				JKS-6
3.8																				JKS-10
6.9																				HSJ-15
9.7																				HSJ-20
16.0																				HSJ-30
2.0																				JKS-6
3.8																				JKS-10
6.9																				HSJ-15
9.7																				HSJ-20
16.0																				HSJ-30
23.3																				HSJ-45
30.0																				HSJ-60
45.0																				HSJ-90
57.9																				HSJ-100
75.0																				HSJ-150
85.8																				HSJ-200
114.1																				HSJ-225
142.6																				HSJ-300
169.0																				HSJ-350
210.6																				HSJ-400
285.3																				HSJ-400

240V AC and 324V DC Input Protection Devices – Wall Mount Frames 1...7 (Continued)

Applied Rating (1)	Frame	Drive Sized for Normal Duty		Drive Sized for Heavy Duty		Input Quantities		AC Input Protection Devices						Input Quantities	DC Input Protection (15)			
		Cont. Output [A]	Output Overload [A]		Cat. No.	Output Overload [A]	Continuous AC Input	Circuit Breaker [A] (6)	Circuit Breaker, Dual Element Time Delay Fuse	Motor Circuit Protector [A] (8)	140M/MT MPCB with Adjustable Current Range (9)(10)		Continuous DC Input					
			60 s	3 s							(x = F or G)	60 s		3 s	[kVA]	[A]	Min Enclosure Volume (in. 3) (7)	Cat. No. (11)
125 Hp	7	312	20x...B312	343.2	468	20x...B360	561.6	121.77	292.9	400	600	400	900	1000	600	[A]	342.3	Bussmann 470MM608
150 Hp	7	360	20x...B360	396	540			140.50	338.0	500	700	500	1000	1200	600	[A]	395.0	Bussmann 470MM612
200 Hp	7	477	20x...B477	524.7	715.5			186.17	447.8	600	900	600	1400	1200	600	[A]	523.3	Bussmann 470MM613

- (1) 'Applied Rating' refers to the motor that will be connected to the drive. For example, a 'C022' drive can be used in Normal Duty mode on a 11kW motor, or in Heavy-duty mode on a 7.5 kW motor. A 'C015' drive can be used in Heavy-duty mode on a 5.5 kW motor with the same ratings as a 'C011'. The drive can be programmed for either mode. Wiring and fuses can be sized based on the programmed mode. For any given drive catalog number, Normal Duty mode provides higher continuous current but smaller overload current regarding Heavy-duty mode. See parameter 306 [Duty Rating].
- (2) For IP66 (NEMA IUL Type 4X/12) enclosures, this drive increases from the frame size listed to the next higher frame size. For example, if this drive is listed as Frame 4, then for all IP ratings other than IP66, it is a Frame 4 and for the IP66 rating, it increases to Frame 5. See table [F2 on page 5](#) for frame/rating cross reference.
- (3) This drive is the next larger frame size.
- (4) Minimum protection device size is the lowest rated device that supplies maximum protection without nuisance tripping.
- (5) Maximum protection device size is the highest rated device that supplies drive protection. For US NEC, minimum size is 125% of motor FLA. Ratings that are shown are maximum.
- (6) Circuit Breaker - inverse time breaker. For US NEC, minimum size is 125% of motor FLA. Ratings that are shown are maximum.
- (7) When using a circuit breaker or time-delay fuse with a drive installed in a ventilated enclosure, the enclosure volume must be greater than or equal to the minimum volume specified in this column. Application-specific thermal considerations can require a larger enclosure.
- (8) Motor Protection Circuit Breaker - instantaneous trip circuit breaker. For US NEC, minimum size is 125% of motor FLA. Ratings that are shown are maximum.
- (9) Bulletin 140M/MT devices with adjustable current range must have the current trip set to the minimum range that the device does not trip.
- (10) Manual Self-Protected (Type E) Combination Motor Controller. UL Listed for use on 208V Wye or Delta, 240V Wye or Delta, 480V Y/277 or 600V Y/347. Not UL Listed for use on 480V or 600V Delta/Delta, corner ground, or high-resistance ground systems.
- (11) The AIC ratings of Bulletin 140M/MT devices can vary. See publication [140-ID005](#) or [140M-ID002](#).
- (12) Bulletin 140MT devices must be Frame C (C3E) or Frame D (D9N).
- (13) Bulletin 140MT Devices must be Frame D (D9E).
- (14) When using a Manual Self-Protected (Type E) Combination Motor Controller, the drive must be installed in a ventilated or non-ventilated enclosure with the minimum volume that is specified in this column. Application-specific thermal considerations can require a larger enclosure.
- (15) See Fuse Certification and Test Data in PowerFlex AC Drives in Common Bus Configurations Application Guidelines, publication [DRIVES-AT002](#) for fuse self-certification and test data for Bussmann 170M and JKS fuses recommended for the DC bus fusing.

400V AC and 540V DC Input Protection Devices – Wall Mount Frames 1...7

Applied Rating ⁽¹⁾	Frame	Cont. Output [A]		Drive Sized For Normal Duty		Drive Sized For Heavy Duty		Input Quantities		AC Input Protection Devices								Input Quantities		DC Input Protection ⁽¹⁴⁾											
		Cat. No.	Output Overload [A]	60 s	3 s	Cat. No.	Output Overload [A]	60 s	3 s	[kVA]	[A]	Dual-element Time-delay Fuse [A]	Non Time-delay Fuse [A]	Circuit Breaker [A] ⁽⁵⁾	Circuit Breaker, Dual-element Time-delay Fuse	Motor Circuit Protector [A] ⁽⁷⁾	140M/MT MPCB with Adjustable Current Range ⁽⁸⁾⁽⁹⁾	Cat. No. ⁽¹⁰⁾	Min Enclosure Volume (in. ³) ⁽¹³⁾	Continuous DC Input	Non-Time Delay Fuse										
																						Min ⁽³⁾	Max ⁽⁴⁾	Min ⁽³⁾	Max ⁽⁴⁾	Min ⁽⁶⁾	Max ⁽⁴⁾	[A]	Min Enclosure Volume (in. ³) ⁽⁶⁾	[A]	[A]
400V AC Input																															
0.37	1	1.3				20x...C2P1	2.3	3.2	0.7	1.1	2	3	2	3	15	3840	3	140M-xxx-B25 140MT-xxx-B25 ⁽¹¹⁾		7269	1.2	JKS-6									
0.75 kW	1	2.1	20x...C2P1	2.3	3.2	20x...C3P5	3.9	5.3	1.2	1.7	2	3	2	3	15	3840	3	140M-xxx-B25 140MT-xxx-B25 ⁽¹¹⁾		7269	2.1	JKS-6									
1.5 kW	1	3.5	20x...C3P5	3.9	5.3	20x...C5P0	5.5	7.5	1.9	2.8	6	6	6	6	15	3840	7	140M-xxx-B40 140MT-xxx-B40 ⁽¹¹⁾		7269	3.7	JKS-8									
2.2 kW	1	5	20x...C5P0	5.5	7.5	20x...C8P7	9.6	13.1	3.1	4.5	6	6	6	6	20	3840	7	140M-xxx-B63 140MT-xxx-B63 ⁽¹¹⁾		7269	5.3	JKS-10									
4.0 kW	1	8.7	20x...C8P7	9.6	13.1	20x...C011	13.1	17.3	5.4	7.8	10	15	10	15	30	3840	15	140M-xxx-C10 140MT-xxx-C10 ⁽¹¹⁾		7269	9.3	HSJ15									
5.5 kW	1	11.5	20x...C011	12.7	17.3	20x...C015	17.3	23.1	7.4	10.7	15	20	15	20	45	3840	15	140M-xxx-C16 140MT-xxx-C16 ⁽¹¹⁾		7269	12.6	HSJ20									
7.5 kW	1	15.4	20x...C015	16.9	23.1				10.1	14.6	20	25	20	25	60	3840	20	140M-xxx-C20 140MT-xxx-C20 ⁽¹¹⁾		7269	17.0	HSJ25									
0.75 kW	2	2.1	20x...C2P1	3.1	3.7	20x...C2P1	3.1	3.7	1.2	1.7	3	6	3	6	15	3840	3	140M-xxx-B25 140MT-xxx-B25 ⁽¹¹⁾		9086	2.1	JKS-6									
1.5 kW	2	3.5	20x...C3P5	5.2	6.3	20x...C3P5	5.2	6.3	1.9	2.8	6	7	6	12	15	3840	7	140M-xxx-B40 140MT-xxx-B40 ⁽¹¹⁾		9086	3.7	JKS-8									
2.2 kW	2	5	20x...C5P0	7.5	9.0	20x...C5P0	7.5	9.0	3.1	4.5	6	10	6	20	20	3840	7	140M-xxx-B63 140MT-xxx-B63 ⁽¹¹⁾		9086	5.3	JKS-10									
4.0 kW	2	8.7	20x...C8P7	13.0	15.6	20x...C8P7	13.0	15.6	5.4	7.8	10	17.5	10	30	30	3840	15	140M-xxx-C10 140MT-xxx-C10 ⁽¹¹⁾		9086	9.3	HSJ15									
5.5 kW	2	11.5	20x...C011	17.2	20.7	20x...C011	17.2	20.7	7.4	10.7	15	25	15	45	45	3840	15	140M-xxx-C16 140MT-xxx-C16 ⁽¹¹⁾		9086	12.6	HSJ20									
7.5 kW	2	15.4	20x...C015	16.9	23.1	20x...C022	24.2	33.0	10.1	14.6	20	30	20	60	60	3840	20	140M-xxx-C20 140MT-xxx-C20 ⁽¹¹⁾		9086	17.0	HSJ25									
11 kW	2	22	20x...C022	24.2	33.0	20x...C030	33.0	45.0	14.6	21.1	30	45	30	80	80	3840	30	140M-xxx-C25 140MT-xxx-C25 ⁽¹²⁾		9086	24.6	HSJ40									
15 kW	3	30	20x...C030	33.0	45.0	20x...C037	45.0	55.5	19.9	28.7	40	60	40	100	100	4800	50	140M-FBE-C32		9086	33.6	HSJ50									
18.5 kW	3	37	20x...C037	40.7	55.5	20x...C043	55.5	66.6	24.5	35.4	45	80	45	125	110	4800	50	140M-FBE-C45		9086	41.4	HSJ70									
22 kW	3	43	20x...C043	47.3	64.5	20x...C060	66.0	90.0	28.5	41.2	55	90	55	150	120	4800	60			9086	48.1	HSJ90									
30 kW	4	60	20x...C060	66.0	90.0	20x...C072	90.0	108.0	39.8	57.4	75	125	75	225	180	4800	100			9086	67.1	HSJ100									
37 kW	4 ⁽²⁾	72	20x...C072	79.2	108.0	20x...C085	108.0	129.6	48.9	70.5	90	150	90	275	200	4800	100			9086	82.4	HSJ125									
45 kW	5	85	20x...C085	93.5	127.5	20x...C104	127.5	156.0	57.7	83.3	110	175	110	325	250	7200	150			9086	97.3	HSJ150									
55 kW	5 ⁽²⁾	104	20x...C104	114.4	156.0	20x...C140	156.0	210.0	71.3	102.9	130	225	130	400	300	7200	150			9086	120.2	HSJ175									
75 kW	6	140	20x...C140	154.0	210.0	20x...C170	210.0	255.0	95.0	137.2	175	300	175	550	400	7200	250			9086	160.3	HSJ250									
90 kW	6	170	20x...C170	187.0	255.0	20x...C205	255.0	307.5	115.4	166.5	225	375	225	600	500	7200	250			9086	194.6	HSJ350									

400V AC and 540V DC Input Protection Devices – Wall Mount Frames 1...7 (Continued)

Applied Rating ⁽¹⁾	Frame	Drive Sized For Normal Duty		Drive Sized For Heavy Duty		Input Quantities		AC Input Protection Devices						Input Quantities		DC Input Protection ⁽¹⁴⁾						
		Cont. Output [A]		Output Overload [A]		Output Overload [A]		Continuous AC Input	140M/MT MPCB with Adjustable Current Range ⁽⁸⁾⁽⁹⁾	Motor Circuit Protector [A] ⁽⁷⁾	Circuit Breaker, Dual-element Time-delay Fuse	Circuit Breaker [A] ⁽⁵⁾	Non Time-delay Fuse [A]	Dual-element Time-delay Fuse [A]	Min Enclosure Volume ⁽⁶⁾ (in. ³)		Cat. No. ⁽¹⁰⁾	Min Enclosure Volume ⁽⁶⁾ (in. ³)	Continuous DC Input	Non-Time Delay Fuse		
		Cat. No.	60 s	3 s	60 s	3 s	[kVA]														[A]	Min ⁽³⁾
400V AC Input																						
110 kW	6	205	20x...C205	225.5	307.5	307.5	20x...C260	307.5	390.0	139.1	200.8	275	450	600	600	600	600	600	400	400	HS1350	234.7
132 kW	6 ⁽²⁾	260	20x...C260	286.0	390.0	390.0	20x...C302	390.0	468.0	176.5	254.7	325	575	700	700	750	750	750	400	400	HS1400	297.7
160 kW	7	302	20x...C302	332.2	453.0	453.0	20x...C367	453.0	550.5	205.0	295.9	400	675	900	900	900	900	900	600	600	Bussmann 170M6608	345.7
200 kW	7	367	20x...C367	403.7	550.5	550.5	20x...C456	550.5	684.0	249.1	359.5	475	800	1100	1100	1000	1000	1000	600	600	Bussmann 170M6612	420.2
250 kW	7	456	20x...C456	501.6	684.0	684.0	20x...C477	684.0	850.5	249.1	359.5	475	800	1300	1300	1000	1000	1000	600	600	Bussmann 170M6612	420.2
270 kW	7	477	20x...C477	524	715.5	715.5				309.5	446.7	600	1000	1400	1400	1400	1400	1400	600	600	Bussmann 170M6613	546.0

(1) Applied rating refers to the motor that is connected to the drive. For example, a C022 drive can be used in Normal Duty mode on a 7.5 kW motor, or in Heavy Duty mode on a 11 kW motor, or in Heavy Duty mode on a 5.5 kW motor with the same ratings as a C011. The drive can be programmed for either mode. Wiring and fuses can be sized based on the programmed mode. For any given drive catalog number, Normal Duty mode provides higher continuous current but smaller overload current when compared to Heavy Duty mode. See parameter 306 [Duty Rating].

(2) For IP66 (NEMA UL Type 4X/12) enclosures, this drive increases from the frame size listed to the next higher frame size. For example, if this drive is listed as Frame 4, then for all IP ratings other than IP66, it is a Frame 4 and for the IP66 rating, it increases to Frame 5. See table 13 on page 6 for frame/rating cross reference.

(3) Minimum protection device size is the lowest rated device that supplies maximum protection without nuisance tripping.

(4) Maximum protection device size is the highest rated device that supplies drive protection. For US NEC, minimum size is 125% of motor F.L.A. Ratings that are shown are maximum.

(5) Circuit breaker - inverse time breaker. For US NEC, minimum size is 125% of motor F.L.A. Ratings that are shown are maximum.

(6) When using a circuit breaker or time-delay fuse with a drive that is installed in a ventilated enclosure, the enclosure volume must be greater than or equal to the minimum volume specified in this column. Application-specific thermal considerations can require a larger enclosure.

(7) Motor Protection Circuit Breaker - instantaneous trip circuit breaker. For US NEC, minimum size is 125% of motor F.L.A. Ratings that are shown are maximum.

(8) Bulletin 140M/MT devices with adjustable current range must have the current trip set to the minimum range that the device does not trip.

(9) Manual Self-Protected (Type E) Combination Motor Controller. UL Listed for 208V Wye or Delta, 240V Wye or Delta, 480V Y/277 or 600V Y/347. Not UL Listed for use on 480V or 600V Delta/Delta, corner ground, or high-resistance ground systems.

(10) The AIC ratings of Bulletin 140M/MT devices can vary. See publication 140-ID005 or 140M-ID002.

(11) Bulletin 140MT devices must be Frame C (C3E) or Frame D (D9N).

(12) Bulletin 140MT Devices must be Frame D (D9E).

(13) When using a Manual Self-Protected (Type E) Combination Motor Controller, the drive must be installed in a ventilated or non-ventilated enclosure with the minimum volume that is specified in this column. Application-specific thermal considerations can require a larger enclosure.

(14) See Fuse Certification and Test Data in PowerFlex AC Drives in Common Bus Configurations Application Guidelines, publication DRIVES-AT002, for fuse self-certification and test data for Bussmann 170M and JKS fuses recommended for the DC bus fusing.

400V AC and 540V DC Input Protection Devices – Floor Mount Frames 8...10

Applied Rating (1)	Frame	Cont. Output [A]	Duty	Cat. No.	Output Overload [A]		Continuous AC Input	AC Input Integral Semiconductor Fuse Size (170M)	DC Bay to Bay Integral Semiconductor Fuse Size (170M)	AC Input Protection Devices Recommended for Branch Circuit Protection (Does not apply to 21G Drives with Options)						Motor Circuit Protector [A]	DC Input Integral Semiconductor Fuse Size (170M)		
					60 s	3 s				[A]	[A]	Dual-element Time-delay Fuse [A]		Non Time-delay Fuse [A]				Circuit Breaker [A] (6)	Max (5)
										1/Phase Min (4)	2/Phase Min (4)	1/Phase Min (4)	2/Phase Min (4)	Max (5)	Max (5)	Max (5)	Max (5)	Max (5)	Max (5)
400V AC Input																			
200 kW	8	385	Heavy	206...C460	578	693	380	1100	–	500	–	850	–	500	–	1100	1100	1600	1600
250 kW	8	460	Normal	206...C460	506	693	455	1100	–	600	–	1000	–	600	–	1300	1300	1600	1600
		456	Heavy	206...C540	684	821	450	1100	–	600	–	1000	–	600	–	1300	1300	1600	1600
315 kW	8	472	Heavy	206...C567	708	851	466	1100	–	700	–	1000	–	700	–	1400	1400	1600	1600
		540	Light	206...C460	594	–	534	1100	–	700	350	1200	700	350	1600	1600	1600	1600	1600
315 kW	8	540	Normal	206...C540	594	821	533	1100	–	700	350	1200	700	350	1600	1600	1600	1600	1600
		540	Heavy	206...C650	810	975	533	1100	–	700	–	1200	700	–	1600	1600	1600	1600	1600
315 kW	8	585	Light	206...C540	644	–	578	1100	–	750	375	1300	750	375	1700	1700	1600	1600	1600
		567	Normal	206...C567	624	851	560	1100	–	750	375	1200	750	375	1700	1700	1600	1600	1600
355 kW	8	585	Heavy	206...C750	878	1125	577	1100	–	750	375	1300	750	375	1700	1700	1600	1600	1600
		612	Light	206...C567	673	–	604	1100	–	800	400	1300	800	400	1800	1800	1600	1600	1600
400 kW	8	650	Normal	206...C650	715	975	640	1100	–	850	425	1400	850	425	1900	1900	1600	1600	1600
		642	Heavy	206...C770	963	1155	634	1100	–	800	400	1400	800	400	1900	1900	1600	1600	1600
400 kW	8	750	Light	206...C650	825	–	739	1100	–	1000	500	1600	1000	500	2200	2200	1600	1600	1600
		750	Normal	206...C750	825	1125	739	1100	–	1000	500	1600	1000	500	2200	2200	1600	1600	1600
450 kW	8	770	Normal	206...C770	847	1155	758	1100	–	1000	500	1700	1000	500	2300	2300	1600	1600	1600
		796	Light	206...C750	876	–	784	1100	–	1000	500	1700	1000	500	2300	2300	1600	1600	1600
400 kW	9	832	Light	206...C770	915	–	819	1100	–	1100	550	1800	1100	550	2400	2400	1600	1600	1600
		750	Heavy	206...C910	1125	1365	739	1100	1400 (3)	900	450	1700	900	450	2200	2200	1600 (3)	1600 (3)	1600 (3)
500 kW	9	880	Heavy	206...C1K0	1320	1584	867	1100	1400 (3)	1100	550	2000	1100	550	2600	2600	1600 (3)	1600 (3)	1600 (3)
		910	Heavy	206...C1K1	1365	1638	896	1100	1400 (3)	1100	550	2000	1100	550	2700	2700	1600 (3)	1600 (3)	1600 (3)
560 kW	9	910	Normal	206...C910	1001	1365	896	1100	1400 (3)	1100	550	2000	1100	550	2700	2700	1600 (3)	1600 (3)	1600 (3)
		1040	Light	206...C910	1144	–	1024	1100	1400 (3)	1300	650	2300	1300	650	3100	3100	1600 (3)	1600 (3)	1600 (3)
630 kW	9	1040	Normal	206...C1K0	1144	1584	1024	1100	1400 (3)	1300	650	2300	1300	650	3100	3100	1600 (3)	1600 (3)	1600 (3)
		1090	Heavy	206...C1K2	1560	1872	1024	1100	1400 (3)	1300	650	2300	1300	650	3100	3100	1600 (3)	1600 (3)	1600 (3)
710 kW	9	1090	Light	206...C1K0	1199	–	1073	1100	1400 (3)	1350	675	2400	1350	675	3200	3200	1600 (3)	1600 (3)	1600 (3)
		1090	Normal	206...C1K1	1199	1638	1073	1100	1400 (3)	1350	675	2400	1350	675	3200	3200	1600 (3)	1600 (3)	1600 (3)
710 kW	9	1090	Heavy	206...C1K4	1635	2198	1073	1100	1400 (3)	1350	675	2400	1350	675	3200	3200	1600 (3)	1600 (3)	1600 (3)
		1175	Light	206...C1K1	1293	–	1157	1100	1400 (3)	1450	725	2600	1450	725	3500	3500	1600 (3)	1600 (3)	1600 (3)
800 kW	10	1175	Normal	206...C1K2	1293	1872	1157	1100	1400 (3)	1450	725	2600	1450	725	3500	3500	1600 (3)	1600 (3)	1600 (3)
		1175	Heavy	206...C1K5	1763	2220	1157	1100	1400 (3)	1450	725	2600	1450	725	3500	3500	1600 (3)	1600 (3)	1600 (3)
850 kW	9	1325	Heavy	206...C1K6	1988	2385	1305	1100	1400 (3)	1650	825	2900	1650	825	3900	3900	1600 (3)	1600 (3)	1600 (3)
		1465	Light	206...C1K2	1612	–	1443	1100	1400 (3)	1800	900	3200	1800	900	4300	4300	1600 (3)	1600 (3)	1600 (3)
850 kW	9	1465	Normal	206...C1K4	1612	2198	1443	1100	1400 (3)	1800	900	3200	1800	900	4300	4300	1600 (3)	1600 (3)	1600 (3)
		1480	Light	206...C1K4	1628	–	1457	1100	1400 (3)	1800	900	3300	1800	900	4400	4400	1600 (3)	1600 (3)	1600 (3)
		1480	Normal	206...C1K5	1628	2220	1457	1100	1400 (3)	1800	900	3300	1800	900	4400	4400	1600 (3)	1600 (3)	1600 (3)

400V AC and 540V DC Input Protection Devices – Floor Mount Frames 8...10 (Continued)

Applied Rating ⁽¹⁾	Frame	Cont. Output [A]	Duty	Cat. No.	Output Overload [A]		Continuous AC Input	AC Input Integral Semiconductor Fuse Size (170M)	DC Bay to Bay Integral Semiconductor Fuse Size (170M)	AC Input Protection Devices Recommended for Branch Circuit Protection (Does not apply to 21G Drives with Options)						Motor Circuit Protector [A] ⁽⁷⁾	Input Quantities	DC Input Integral Semiconductor Fuse Size ⁽⁸⁾ (170M)
					60 s	3 s				1/Phase Min ⁽⁴⁾	2/Phase Min ⁽⁴⁾	Max ⁽⁵⁾	1/Phase Min ⁽⁴⁾	2/Phase Min ⁽⁴⁾	Max ⁽⁵⁾			
900 kW	9	1600	Light	206...C1K5	1760	—	1576	1100	1400 ⁽³⁾	400V AC Input						1600 ⁽³⁾	540V DC Input	1600 ⁽³⁾
	10	1590	Normal	206...C1K6	1749	2385	1566	1100	1400 ⁽³⁾	1950	975	3500	1950	975	4700	4700		1841
1000 kW	10	1715	Light	206...C1K6	1887	2058	1689	1100	1400 ⁽³⁾	1950	975	3500	1950	975	4700	4700	1830	1600 ⁽³⁾
										2100	1050	3800	2100	1050	5100	5100	1974	1600 ⁽³⁾
1250 kW	10	2150	Normal	206...C2K1	2365	3240	2117	1100	1400 ⁽³⁾	2200	1100	4000	2200	1100	5300	5300	2071	1600 ⁽³⁾
										2650	1325	4800	2650	1325	6400	6400	2474	1600 ⁽³⁾
1400 kW	10	2330	Light	206...C2K1	2563	2796	2294	1100	1400 ⁽³⁾	2850	1425	5200	2850	1425	6900	6900	2681	1600 ⁽³⁾

(1) Applied rating refers to the motor that is connected to the drive. For example, a C460 drive can be used in Normal Duty mode on a 250 kW motor, in Heavy Duty mode on a 200 kW motor or in Light Duty mode on a 315 kW motor. The drive can be programmed for each mode. Wiring and fuses can be sized based on the programmed mode. For any given drive catalog number, Normal Duty mode provides higher continuous current but smaller overload current when compared to Heavy Duty mode. See parameter 306 [Duty Rating].

(2) These AC line fuses (with blown fuse indicators) are included in the drive to provide drive short circuit protection. AC input protection devices for branch circuit protection based on US NEC are listed in the table. Each drive bay has one fuse per phase.

(3) Each drive bay has one fuse per DC line.

(4) Minimum protection device size is the lowest rated device that supplies maximum protection without nuisance tripping.

(5) Maximum protection device size is the highest rated device that supplies drive protection. For US NEC, minimum size is 125% of motor F.L.A. Ratings that are shown are maximum.

(6) Circuit breaker – inverse time breaker. For US NEC, minimum size is 125% of motor F.L.A. Ratings that are shown are maximum.

(7) Recommended motor circuit protector – instantaneous trip circuit breaker. The trip setting must be set to the input current of the drive and must be sized for the continuous current of the system.

(8) These DC line fuses (with blown fuse indicators) are included in the drive to provide drive short circuit protection.

480V AC and 650V DC Input Protection Devices – Wall Mount Frames 1...7

Applied Rating ⁽¹⁾	Frame	Drive Sized For Normal Duty		Drive Sized For Heavy Duty		Input Quantities		AC Input Protection Devices						DC Input Protection ^(1,4)													
		Cat. No.	Output Overload [A]	60 s	3 s	Cat. No.	Output Overload [A]	60 s	3 s	[kVA]	[A]	Min ⁽³⁾	Max ⁽⁴⁾	Dual-element Time-delay Fuse [A]	Non-Time Delay Fuse Min ⁽³⁾	Max ⁽⁴⁾	Circuit Breaker, Dual-element Time-delay Fuse Min Enclosure Volume (in. ³) ⁽⁶⁾	Motor Circuit Protector [A]	140M/MT MPCB with Adjustable Current Range ⁽⁸⁾⁽⁹⁾	Cat. No. ⁽¹⁰⁾	Min Enclosure Volume (in. ³) ⁽¹³⁾	Continuous DC Input	Non-Time Delay Fuse				
																								[A]	[A]	[A]	[A]
480V AC Input																											
0.5 Hp	1	1.1				20x...D2P1	2.3	3.2	0.7	0.9	2	3	2	3	15	3840		3	140M-xxx-B25 140MT-xxx-B25 ⁽¹¹⁾	7269	1.0	JKS-6					
1.0 Hp	1	2.1	20x...D2P1	2.3	3.2	20x...D3P4	3.7	5.1	1.3	1.6	2	3	2	3	15	3840		3	140M-xxx-B25 140MT-xxx-B25 ⁽¹¹⁾	7269	1.9	JKS-6					
2.0 Hp	1	3.4	20x...D3P4	3.7	5.1	20x...D5P0	5.5	7.5	2.2	2.6	6	6	6	6	15	3840		7	140M-xxx-B40 140MT-xxx-B40 ⁽¹¹⁾	7269	3.0	JKS-6					
3.0 Hp	1	5	20x...D5P0	5.5	7.5	20x...D8P0	8.8	12.0	3.2	3.9	6	6	6	6	20	3840		7	140M-xxx-B63 140MT-xxx-B63 ⁽¹¹⁾	7269	4.5	JKS-10					
5.0 Hp	1	8	20x...D8P0	8.8	12.0	20x...D011	12.1	16.5	5.7	6.9	10	15	10	15	30	3840		15	140M-xxx-C10 140MT-xxx-C10 ⁽¹¹⁾	7269	8.1	HS115					
7.5 Hp	1	11	20x...D011	12.1	16.5	20x...D014	16.5	21.0	7.9	9.5	15	20	15	20	40	3840		15	140M-xxx-C16 140MT-xxx-C16 ⁽¹¹⁾	7269	11.1	HS120					
10 Hp	1	14	20x...D014	15.4	21.0				10.4	12.5	20	25	20	25	50	3840		20	140M-xxx-C16 140MT-xxx-C16 ⁽¹¹⁾	7269	14.7	HS130					
1.0 Hp	2	2.1	20x...D2P1	3.1	3.7	20x...D2P1	3.1	3.7	1.3	1.6	2	6	2	8	15	3840		3	140M-xxx-B25 140MT-xxx-B25 ⁽¹¹⁾	9086	1.9	JKS-6					
2.0 Hp	2	3.4	20x...D3P4	5.1	6.1	20x...D3P4	5.1	6.1	2.2	2.6	4	7	4	12	15	3840		7	140M-xxx-B40 140MT-xxx-B40 ⁽¹¹⁾	9086	3.0	JKS-6					
3.0 Hp	2	5	20x...D5P0	7.5	9.0	20x...D5P0	7.5	9.0	3.2	3.9	6	10	6	20	20	3840		7	140M-xxx-B63 140MT-xxx-B63 ⁽¹¹⁾	9086	4.5	JKS-10					
5.0 Hp	2	8	20x...D8P0	12.0	14.4	20x...D8P0	12.0	14.4	5.7	6.9	10	17.5	10	30	30	3840		15	140M-xxx-C10 140MT-xxx-C10 ⁽¹¹⁾	9086	8.1	HS115					
7.5 Hp	2	11	20x...D011	16.5	19.8	20x...D011	16.5	19.8	7.9	9.5	12	20	12	40	40	3840		15	140M-xxx-C16 140MT-xxx-C16 ⁽¹¹⁾	9086	11.1	HS120					
10 Hp	2	14	20x...D014	15.4	21.0	20x...D014	16.5	21.0	7.9	9.5	12	20	12	40	40	3840		15	140M-xxx-C16 140MT-xxx-C16 ⁽¹¹⁾	9086	11.1	HS120					
15 Hp	2	22	20x...D022	24.2	33.0	20x...D027	33.0	40.5	16.6	19.9	30	50	30	80	80	3840		30	140M-xxx-C25 140MT-xxx-C25 ⁽¹²⁾	9086	23.3	HS140					
20 Hp	3	27	20x...D027	29.7	40.5	20x...D034	40.5	51.0	20.6	24.8	35	60	35	100	100	4800		50	140M-F8E-C32	9086	28.9	HS150					
25 Hp	3	34	20x...D034	37.4	51.0	20x...D040	51.0	61.2	25.9	31.2	45	75	45	125	100	4800		50	140M-F8E-C45	9086	36.4	HS160					
30 Hp	3	40	20x...D040	44.0	60.0	20x...D052	60.0	78.0	30.5	36.7	50	90	50	150	120	4800		50	140M-F8E-C45	9086	42.9	HS180					
40 Hp	4	52	20x...D052	57.2	78.0	20x...D065	78.0	97.5	39.7	47.7	65	110	65	200	150	4800		70	140M-F8E-C45	9086	55.7	HS190					
50 Hp	4 ⁽²⁾	65	20x...D065	71.5	97.5	20x...D077	97.5	117.0	49.6	59.6	90	125	90	250	175	4800		100	140M-F8E-C45	9086	69.7	HS1100					
60 Hp	5	77	20x...D077	84.7	115.5	20x...D096	115.5	144.0	60.1	72.3	100	170	100	300	225	7200		100	140M-F8E-C45	9086	84.5	HS1150					
75 Hp	5 ⁽²⁾	96	20x...D096	105.6	144.0	20x...D125	144.0	187.5	74.9	90.1	125	200	125	375	275	7200		125	140M-F8E-C45	9086	105.3	HS1175					
100 Hp	6	125	20x...D125	137.5	187.5	20x...D156	187.5	234.0	97.6	117.4	175	275	175	500	375	7200		250	140M-F8E-C45	9086	137.1	HS1200					
125 Hp	6	156	20x...D156	171.6	234.0	20x...D186	234.0	280.8	121.8	146.5	200	350	200	600	450	7200		250	140M-F8E-C45	9086	171.2	HS1300					
150 Hp	6	186	20x...D186	204.6	279.0	20x...D248	279.0	372.0	145.2	174.6	250	400	250	600	550	7200		250	140M-F8E-C45	9086	204.1	HS1400					
200 Hp	6 ⁽²⁾	248	20x...D248	272.8	372.0	20x...D302	372.0	453.0	193.6	232.8	325	550	325	700	700	7200		400	140M-F8E-C45	9086	272.1	HS1400					

480V AC and 650V DC Input Protection Devices – Wall Mount Frames 1...7 (Continued)

Applied Rating ⁽¹⁾	Frame	Drive Sized For Normal Duty		Drive Sized For Heavy Duty		Input Quantities		AC Input Protection Devices						DC Input Protection ⁽¹⁴⁾			
		Output [A]		Output Overload [A]		Cat. No.		Continuous AC Input	Non-Time Delay Fuse	Circuit Breaker, Dual-element Time-delay Fuse	Circuit Breaker, Motor Circuit Protector [A]	140M/MT MPCB with Adjustable Current Range ⁽⁸⁾⁽⁹⁾	Continuous DC Input	Non-Time Delay Fuse			
		60 s	3 s	60 s	3 s	(x = F or G)	(x = F or G)	[kVA]	[A]	Min ⁽³⁾	Max ⁽⁴⁾	Min Enclosure Volume (in. ³) ⁽⁶⁾	Max ⁽⁴⁾	[A]	Min Enclosure Volume (in. ³) ⁽¹³⁾		
480V AC Input																	
250 Hp	7	302	332.2	453.0	453.0	20x...D361	20x...D361	283.5	400	675	400	900	900	600	600	331.3	Bussmann 170M6608
300 Hp	7	361	397.1	541.5	541.5	20x...D415	20x...D415	338.9	475	800	475	1000	1000	600	600	396.1	Bussmann 170M6612
350 Hp	7	415	456.5	622.5	622.5	20x...D415	20x...D477	338.9	475	800	475	1000	1000	600	600	396.1	Bussmann 170M6612
400 Hp	7	477	524.7	715.5	715.5	20x...D477		372.3	600	1000	600	1400	1400	600	600	455.3	Bussmann 170M6612
								372.3	600	1000	600	1400	1400	600	600	523.3	Bussmann 170M6613

(1) Applied rating refers to the motor that is connected to the drive. For example, a D022 drive can be used in Normal Duty mode on a 15 Hp motor, or in Heavy Duty mode on a 10 Hp motor. A D074 drive can be used in Heavy Duty mode on a 7.5 Hp motor with the same ratings as a D011. The drive can be programmed for either mode. Wiring and fuses can be sized based on the programmed mode. For any given drive catalog number, Normal Duty mode provides higher continuous current but smaller overload current when compared to Heavy Duty mode. See parameter 306 [Duty Rating].

(2) For IP66 (NEMA /UL Type 4X/12) enclosures, this drive increases from the frame size listed to the next higher frame size. For example, if this drive is listed as Frame 4, then for all IP ratings other than IP66, it is a Frame 4 and for the IP66 rating, it increases to Frame 5. See table 14 on page 6 for frame/rating cross reference.

(3) Minimum protection device size is the lowest rated device that supplies maximum protection without nuisance tripping.

(4) Maximum protection device size is the highest rated device that supplies drive protection. For US NEC, minimum size is 125% of motor FLA. Ratings that are shown are maximum.

(5) Circuit breaker - inverse time breaker. For US NEC, minimum size is 125% of motor FLA. Ratings that are shown are maximum.

(6) When using a circuit breaker or time-delay fuse with a drive that is installed in a ventilated enclosure, the enclosure volume must be greater than or equal to the minimum volume specified in this column. Application specific thermal considerations can require a larger enclosure.

(7) Motor Protection Circuit Breaker - instantaneous trip circuit breaker. For US NEC, minimum size is 125% of motor FLA. Ratings that are shown are maximum.

(8) Bulletin 140M/MT devices with adjustable current range must have the current trip set to the minimum range that the device does not trip.

(9) Manual Self-Protected (Type E) Combination Motor Controller, UL Listed for 208V Wye or Delta, 240V Wye or Delta, 480V Y/277 or 600V Y/347. Not UL Listed for use on 480V or 600V Delta/Delta, corner ground, or high-resistance ground systems.

(10) The AIC ratings of Bulletin 140M/MT devices can vary. See publication 140-TD005 or 140M-TD002.

(11) Bulletin 140MT devices must be Frame C (C3E) or Frame D (D9N).

(12) Bulletin 140MT devices must be Frame D (D9E).

(13) When using a Manual Self-Protected (Type E) Combination Motor Controller, the drive must be installed in a ventilated or non-ventilated enclosure with the minimum volume that is specified in this column. Application-specific thermal considerations can require a larger enclosure.

(14) See Fuse Certification and Test Data in PowerFlex AC Drives in Common Bus Configurations Application Guidelines, publication DRIVES-AT002, for fuse self-certification and test data for Bussmann 170M and JKS fuses recommended for the DC bus fusing.

480V AC and 650V DC Input Protection Devices – Floor Mount Frames 8...10

Applied Rating (1)	Frame	Cont. Output (A)	Duty	Cat. No.	Output Overload (A)		Continuous AC Input (A)	AC Input Integral Semiconductor Fuse Size (170M)	DC Bay to Bay Integral Semiconductor Fuse Size (170M)	AC Input Protection Devices Recommended for Branch Circuit Protection (Does not apply to 21G Drives with Options)						Input Quantities Continuous DC Input	DC Input Integral Semiconductor Fuse Size (170M)		
					60 s	3 s				Dual-element Time-delay Fuse (A)			Non Time-delay Fuse (A)					Circuit Breaker (A)	Motor Circuit Protector (A) (7)
										1/Phase Min (4)	2/Phase Min (4)	Max (5)	1/Phase Min (4)	2/Phase Min (4)	Max (5)				
480V AC Input																			
300 Hp	8	370	Heavy	206...D430	555	666	349	1100	–	450	–	800	450	–	1100	1100	450	1600	
350 Hp	8	430	Normal	206...D430	473	666	406	1100	–	550	–	900	1200	–	1200	1200	1200	1600	
		414	Heavy	206...D485	621	745	391	1100	–	500	–	900	1200	–	1200	1200	1200	1600	
400 Hp	8	454	Heavy	206...D545	681	818	428	1100	–	550	–	1000	1300	–	1300	1300	1300	1600	
		485	Light	206...D430	534	–	458	1100	–	600	–	1000	1400	–	1400	1400	1400	1600	
		485	Normal	206...D485	534	745	458	1100	–	600	–	1000	1400	–	1400	1400	1400	1600	
		485	Heavy	206...D617	728	926	458	1100	–	600	–	1000	1400	–	1400	1400	1400	1600	
450 Hp	8	545	Light	206...D485	600	–	514	1100	–	650	–	1200	1600	–	1600	1600	1600	1600	
		545	Normal	206...D545	600	818	514	1100	–	650	–	1200	1600	–	1600	1600	1600	1600	
500 Hp	8	545	Heavy	206...D710	818	1065	514	1100	–	650	325	1200	1600	325	1600	1600	1600	1600	
		590	Light	206...D545	649	–	557	1100	–	700	–	1300	1700	–	1700	1700	1700	1600	
600 Hp	8	617	Normal	206...D617	679	926	582	1100	–	750	325	1300	1800	325	1800	1800	1800	1600	
		617	Heavy	206...D740	926	1110	582	1100	–	750	375	1300	2400	375	2400	1800	1800	1600	
650 Hp	8	710	Light	206...D617	781	–	670	1100	–	850	425	1500	2100	425	2100	2100	2100	1600	
		710	Normal	206...D710	781	1065	670	1100	–	850	425	1500	2100	425	2100	2100	2100	1600	
700 Hp	8	765	Light	206...D710	842	–	722	1100	–	1000	500	1700	2200	500	2200	2200	2200	1600	
		740	Normal	206...D740	814	1110	698	1100	–	900	450	1600	2200	450	2200	2200	2200	1600	
700 Hp	8	800	Light	206...D740	880	–	755	1100	–	1000	500	1800	2400	500	1800	2400	1000	1600 (3)	
600 Hp	9	710	Heavy	206...D800	1065	1278	670	1100	1400 (3)	850	425	1500	2000	425	2000	2000	850	1600 (3)	
700 Hp	9	795	Heavy	206...D960	1193	1440	750	1100	1400 (3)	950	475	1700	2300	475	2300	2300	950	1600 (3)	
750 Hp	9	800	Normal	206...D800	880	1278	755	1100	1400 (3)	950	475	1700	2300	475	2300	2300	950	1600 (3)	
		800	Heavy	206...D1K0	1200	1568	755	1100	1400 (3)	950	475	1700	2300	475	2300	2300	950	1600 (3)	
800 Hp	9	960	Light	206...D800	1056	–	906	1100	1400 (3)	1150	575	2000	2700	575	2700	2700	1150	1600 (3)	
		960	Normal	206...D960	1056	1440	906	1100	1400 (3)	1150	575	2000	2700	575	2700	2700	1150	1600 (3)	
900 Hp	9	1045	Light	206...D1K0	1150	–	986	1100	1400 (3)	1250	625	2200	3000	625	3000	3000	1250	1600 (3)	
		1045	Normal	206...D1K0	1150	1568	986	1100	1400 (3)	1250	625	2200	3000	625	3000	3000	1250	1600 (3)	
1000 Hp	9	1045	Heavy	206...D1K3	1568	2048	986	1100	1400 (3)	1250	625	2200	3000	625	3000	3000	1250	1600 (3)	
		1135	Light	206...D1K0	1249	–	1071	1100	1400 (3)	1350	675	2400	3200	675	3200	3200	1350	1600 (3)	
1100 Hp	9	1135	Normal	206...D1K2	1249	1728	1071	1100	1400 (3)	1350	675	2400	3200	675	3200	3200	1350	1600 (3)	
		1135	Heavy	206...D1K4	1703	2130	1071	1100	1400 (3)	1350	675	2400	3200	675	3200	3200	1350	1600 (3)	
1250 Hp	9	1365	Light	206...D1K3	1502	–	1288	1100	1400 (3)	1600	800	2900	3900	800	3900	3900	1600	1600 (3)	
		1365	Normal	206...D1K3	1502	2048	1288	1100	1400 (3)	1600	800	2900	3900	800	3900	3900	1600	1600 (3)	
1250 Hp	9	1420	Heavy	206...D1K5	1905	2288	1199	1100	1400 (3)	1500	750	2700	3600	750	3600	3600	1500	1600 (3)	
		1420	Light	206...D1K3	1562	–	1340	1100	1400 (3)	1700	850	3000	4000	850	4000	4000	1700	1600 (3)	
		1420	Normal	206...D1K4	1562	2130	1340	1100	1400 (3)	1700	850	3000	4000	850	4000	4000	1700	1600 (3)	

480V AC and 650V DC Input Protection Devices – Floor Mount Frames 8...10 (Continued)

Applied Rating ⁽¹⁾	Frame	Cont. Output [A]	Duty	Cat. No.	Output Overload [A]		Continuous AC Input	AC Input Integral Semiconductor Fuse Size (170M) ⁽²⁾	DC Bay to Bay Integral Semiconductor Fuse Size (170M)	AC Input Protection Devices Recommended for Branch Circuit Protection (Does not apply to 21G Drives with Options)						Input Quantities Continuous DC Input	DC Input Integral Semiconductor Fuse Size (170M) ⁽⁸⁾			
					60 s	3 s				Time-delay Fuse [A]		Non Time-delay Fuse [A]		Circuit Breaker [A] ⁽⁶⁾	Motor Circuit Protector [A] ⁽⁷⁾					
										1/Phase Min ⁽⁴⁾	2/Phase Min ⁽⁴⁾	Max ⁽⁵⁾	1/Phase Min ⁽⁴⁾					2/Phase Min ⁽⁴⁾	Max ⁽⁵⁾	
480V AC Input																				
1350 Hp	9	1540	Light	206...D1K4	1694	—	1453	1100	1400 ⁽³⁾	1800	900	3300	1800	900	4400	4400	4400	4400	1800	1600 ⁽³⁾
	10	1525	Normal	206...D1K5	1678	2288	1439	1100	1400 ⁽³⁾	1800	900	3200	1800	900	4300	4300	4300	4300	1800	1600 ⁽³⁾
1500 Hp	10	1655	Light	206...D1K5	1821	1986	1562	1100	1400 ⁽³⁾	1950	975	3500	1950	975	4700	4700	4700	4700	1950	1600 ⁽³⁾
1650 Hp	10	1730	Heavy	206...D2K0	2595	3114	1633	1100	1400 ⁽³⁾	2050	1025	3700	2050	1025	4900	4900	4900	4900	2050	1600 ⁽³⁾
1750 Hp	10	2070	Normal	206...D2K0	2277	3114	1953	1100	1400 ⁽³⁾	2450	1225	4400	2450	1225	5900	5900	5900	5900	2450	1600 ⁽³⁾
2000 Hp	10	2240	Light	206...D2K0	2464	2688	2114	1100	1400 ⁽³⁾	2650	1325	4800	2650	1325	6300	6300	6300	6300	2650	1600 ⁽³⁾

(1) Applied rating refers to the motor that is connected to the drive. For example, a D430 drive can be used in Normal Duty mode on a 350 Hp motor, in Heavy Duty mode on a 300 Hp motor or in Light Duty mode on a 400 Hp motor. The drive can be programmed for each mode. Wiring and fuses can be sized based on the programmed mode. For any given drive catalog number, Normal Duty mode provides higher continuous current but smaller overload current when compared to Heavy Duty mode. See parameter 306 [Duty Rating].

(2) These AC line fuses (with blown fuse indicators) are included in the drive to provide drive short circuit protection. AC input protection devices for branch circuit protection based on US NEC are listed in the table. Each drive bay has one fuse per phase.

(3) Each drive bay has one fuse per DC line.

(4) Minimum protection device size is the lowest rated device that supplies maximum protection without nuisance tripping.

(5) Maximum protection device size is the highest rated device that supplies drive protection. For US NEC, minimum size is 125% of motor F.L.A. Ratings that are shown are maximum.

(6) Circuit breaker – inverse time breaker. For US NEC, minimum size is 125% of motor F.L.A. Ratings that are shown are maximum.

(7) Motor Protection Circuit Breaker – instantaneous trip circuit breaker. For US NEC, minimum size is 125% of motor F.L.A. Ratings that are shown are maximum.

(8) These DC line fuses (with blown fuse indicators) are included in the drive to provide drive short circuit protection.

600V AC and 810V DC Input Protection Devices – Wall Mount Frames 3...7

Applied Rating (1)	Frame	Cont. Output [A]		Drive Sized For Normal Duty		Drive Sized For Heavy Duty		Continuous AC Input		AC Input Protection Devices						Input Quantities	DC Input Protection (15)				
		Cat. No.	Output Overload [A]	60 s	3 s	Cat. No.	Output Overload [A]	60 s	3 s	[A]	Min (2)	Max (3)	Dual-element Time-delay Fuse [A]	Non Time-delay Fuse [A]	Circuit Breaker [A]			Circuit Breaker, Dual-element Time-delay Fuse	Motor Circuit Protector [A] (8)	140M/MT MPCB with Adjustable Current Range (9)(10)	Cat. No. (11)
																(x = F or G)	(x = F or G)				
600V AC Input																					
0.5 Hp	3	0.9				20x...E1P7	1.4	2.6	0.8	1	2	1	3	3	4800	1	140M-xxx-B16 (12) 140MT-xxx-B16 (12)	9086	1.0	JKS-2	
1 Hp	3	1.7	20x...E1P7	1.9	2.6	20x...E2P7	2.6	4.1	1.6	2	4	2	5	5	4800	2	140M-xxx-B25 140MT-xxx-B25 (12)	9086	1.9	JKS-4	
2 Hp	3	2.7	20x...E2P7	3.0	4.1	20x...E3P9	4.1	5.9	2.5	3	6	3	8	8	4800	3	140M-xxx-B40 140MT-xxx-B40 (12)	9086	3.0	JKS-5	
3 Hp	3	3.9	20x...E3P9	4.3	5.9	20x...E6P1	5.9	9.2	3.7	5	8	5	11(4), 10(5)	11(4), 20(5)	4800	5	140M-DBE-B63 140MT-D9E-B63	9086	4.3	JKS-8	
5 Hp	3	6.1	20x...E6P1	6.7	9.2	20x...E9P0	9.2	13.5	5.7	7	13	7	15	20	4800	10	140M-DBE-B63 140MT-D9E-B63	9086	6.7	HS110	
7.5 Hp	3	9	20x...E9P0	9.9	13.5	20x...E011	13.5	16.5	8.4	11	19	11	25	30	4800	15	140M-xxx-C10 140MT-xxx-C10 (13)	9086	9.9	HS115	
10 Hp	3	11	20x...E011	12.1	16.5	20x...E017	16.5	25.5	10.3	13	23	13	30	40	4800	15	140M-xxx-C16 140MT-xxx-C16 (13)	9086	12.0	HS120	
15 Hp	3	17	20x...E017	18.7	25.5	20x...E022	25.5	33.0	16.0	20	36	20	50	50	4800	20	140M-FBE-C20	9086	18.6	HS130	
20 Hp	3	22	20x...E022	24.2	33.0				20.7	26	46	26	60	70	4800	30	140M-FBE-C25	9086	24.1	HS140	
25 Hp	4	27	20x...E027	29.7	40.5	20x...E032	40.5	48.6	25.3	32	57	32	75	80	4800	35	140M-FBE-C32	9086	24.1	HS140	
30 Hp	4	32	20x...E032	35.2	48.0				30.0	38	68	38	90	100	4800	40	140M-FBE-C32	9086	29.6	HS150	
40 Hp	5	41	20x...E041	45.1	61.5	20x...E052	61.5	78.0	38.5	48	87	48	115	120	7200	50	140M-FBE-C32	13630	35.0	HS160	
50 Hp	5	52	20x...E052	57.2	78.0				48.8	61	110	61	145	150	7200	65			44.9	HS170	
7.5 Hp	6	9.1				20x...E012	13.7	18.0	8.5	11	19	11	25	30	7200	15	140M-xxx-C10 (13) 140MT-xxx-C10 (13)	14400	56.9	HS190	
10 Hp	6	12	20x...E012	13.2	18.0	20x...E018	18.0	27.0	11.3	14	25	14	35	40		15	140M-xxx-C16 140MT-xxx-C16 (13)	14400	10.0	HS115	
15 Hp	6	18	20x...E018	19.8	27.0	20x...E023	27.0	34.5	16.9	21	38	21	50	60		25	140M-FBE-C20	14400	13.1	HS120	
20 Hp	6	23	20x...E023	25.3	34.5	20x...E028	34.5	42.0	21.6	27(6), 25(5)	49(4), 50(5)	27(4), 25(5)	65	70		30	140M-FBE-C25	14400	19.7	HS130	
25 Hp	6	24	20x...E024	26.4	36.0				22.5	28	51	28	70	70		30	140M-FBE-C25	14400	25.2	HS140	
30 Hp	6	28	20x...E028	30.8	42.0	20x...E033	42.0	50.4	26.3	35	60	35	80	80		30	140M-FBE-C25	14400	26.3	HS140	
40 Hp	6	33	20x...E033	36.3	49.5	20x...E042	49.5	63.0	31.0	40	70	40	95	100		35	140M-FBE-C32	14400	24.1	HS140	
50 Hp	6	42	20x...E042	46.2	63.0	20x...E053	63.0	79.5	39.4	50	90	50	120	120		40	140M-FBE-C32	14400	30.7	HS150	
60 Hp	6	53(4), 57(5)	20x...E053	58.3	79.5	20x...E063	78.0	94.5	49.8(4), 48.8(5)	60	110	60	150(4), 145(5)	150		65			36.1	HS160	
75 Hp	6	63	20x...E063	69.3	94.5	20x...E077	94.5	115.5	59.1	75	135	75	175	180		75			46.0	HS170	
100 Hp	6	77	20x...E077	84.7	115.5	20x...E099	115.5	148.5	72.3	90	165	90	215	220		95			58.0(4), 56.9(5)	HS190	
125 Hp	6	99	20x...E099	108.9	148.5	20x...E125	148.5	187.5	92.9	115	210	115	280	280		120			69.0	HS110	
	6	125	20x...E125	137.5	187.5	20x...E144	187.5	225.0	117.4	145	265	145	350	360		150			84.3	HS150	
	6																		108.4	HS175	
	6																		136.8	HS225	

600V AC and 810V DC Input Protection Devices – Wall Mount Frames 3...7 (Continued)

Applied Rating ⁽¹⁾	Frame	Drive Sized For Normal Duty		Drive Sized For Heavy Duty		Continuous AC Input		AC Input Protection Devices						Input Quantities		DC Input Protection ⁽¹⁵⁾ Non-Time Delay Fuse		
		Cat. No.	Output Overload [A]	Cat. No.	Output Overload [A]	Cat. No.	3 s	Cat. No.	3 s	Dual-element Time-delay Fuse [A]		Circuit Breaker [A]	Circuit Breaker, Dual-element Time-delay Fuse	Motor Circuit Protector [A] ⁽⁹⁾	140M/MT MPCB with Adjustable Current Range ⁽⁹⁾⁽¹⁰⁾		Continuous DC Input	
										Min ⁽²⁾	Max ⁽³⁾							Min ⁽²⁾
600V AC Input																		
150 Hp	6	20x...E144	158.4	216.0	20x...E192	216.0	288.0	135.2	170	300	170	400	400	170	170	400	170	HSJ250
	7	20x...E192			20x...E242	288.0	363.0	135.2	170	305	170	405	410	170	170	410	170	HSJ250
200 Hp	7	20x...E192	211.2	288.0	20x...E242	288.0	363.0	180.3	225	405	225	540	550	230	230	550	230	HSJ350
250 Hp	7	20x...E242	266.2	363.0	20x...E289	363.0	435.6	227.2	285	510	285	680	690	285	285	680	285	HSJ400
300 Hp	7	20x...E289	317.9	433.5				271.3	340	600	340	800	800	340	340	800	340	HSJ500

(1) Applied rating refers to the motor that is connected to the drive. For example, a E063 drive can be used in Normal Duty mode on a 60 Hp motor, in Heavy Duty mode on a 50 Hp motor. The drive can be programmed for each mode. Wiring and fuses can be sized based on the programmed mode. For any given drive catalog number, Normal Duty mode provides higher continuous current but smaller overload current when compared to Heavy Duty mode. See parameter 306 [Duty Rating].

(2) Minimum protection device size is the lowest rated device that supplies maximum protection without nuisance tripping.

(3) Maximum protection device size is the highest rated device that supplies drive protection. For US NEC, minimum size is 125% of motor FLA. Ratings that are shown are maximum.

(4) Normal duty.

(5) Heavy duty.

(6) Circuit breaker – inverse time breaker. For US NEC, minimum size is 125% of motor FLA. Ratings that are shown are maximum.

(7) When using a circuit breaker or time-delay fuse with a drive that is installed in a ventilated enclosure, the enclosure volume must be greater than or equal to the minimum volume specified in this column. Application specific thermal considerations can require a larger enclosure.

(8) Motor Protection Circuit Breaker – instantaneous trip circuit breaker. For US NEC, minimum size is 125% of motor FLA. Ratings that are shown are maximum.

(9) Bulletin 140M/MT devices with adjustable current range must have the current trip set to the minimum range that the device does not trip.

(10) Manual Self-Protected (Type E) Combination Motor Controller. UL Listed for 208V Wye or Delta, 240V Wye or Delta, 480V Y/277 or 600V Y/347. Not UL Listed for use on 480V or 600V Delta/Delta, corner ground, or high-resistance ground systems.

(11) The AC ratings of Bulletin 140M/MT devices can vary. See publication [140-ID005](#) or [140M-ID002](#).

(12) Bulletin 140MT devices must be Frame C (C3E) or Frame D (D9N).

(13) Bulletin 140MT devices must be Frame D (D9E).

(14) When using a Manual Self-Protected (Type E) Combination Motor Controller, the drive must be installed in a ventilated or non-ventilated enclosure with the minimum volume that is specified in this column. Application-specific thermal considerations can require a larger enclosure.

(15) See Fuse Certification and Test Data in PowerFlex AC Drives in Common Bus Configurations Application Guidelines; publication [DRIVES-AT002](#), for fuse self-certification and test data for Bussmann 170M and JKS fuses recommended for the DC bus fusing.

600V AC and 810V DC Input Protection Devices – Floor Mount Frames 8...10

Applied Rating (1)	Frame	Cont. Output (A)	Duty	Cat. No.	Output Overload (A)		Continuous AC Input	AC Input Integral Semiconductor Fuse Size (170M) (2)	DC Bay to Bay Integral Semiconductor Fuse Size (170M6648)	AC Input Protection Devices Recommended for Branch Circuit Protection (Does not apply to 21G Drives with Options)						Input Quantities	DC Input Integral Semiconductor Fuse Size (170M6253) (7)	
					60 s	3 s				Dual-element Time-delay Fuse (A)			Non Time-delay Fuse (A)					Circuit Breaker (A)
							[A]	[A]	[A]	1/Phase Min (3)	2/Phase Min (3)	Max (4)	1/Phase Min (3)	2/Phase Min (3)	Max (4)	[A]	[A]	
600V AC Input																		
250Hp	8	272	Heavy	206...E295	408	490	257	900	–	350	175	600	350	175	800	800	350	1000
300Hp	8	295	Heavy	206...E355	443	533	278	900	–	350	175	700	350	175	900	900	350	1000
		295	Normal	206...E295	325	490	278	900	–	400	200	700	400	200	1000	1000	400	1000
350Hp	8	355	Light	206...E295	391	–	335	900	–	450	225	800	450	225	1100	1100	450	1000
		355	Normal	206...E355	391	533	335	900	–	450	225	800	450	225	1100	1100	450	1000
		329	Heavy	206...E395	494	593	310	900	–	400	200	700	400	200	1000	1000	400	1000
		355	Heavy	206...E435	533	639	335	900	–	450	225	800	450	225	1100	1100	450	1000
400Hp	8	395	Light	206...E355	435	–	373	900	–	500	250	900	500	250	1200	1200	500	1000
		395	Normal	206...E395	435	593	373	900	–	500	250	900	500	250	1200	1200	500	1000
		395	Heavy	206...E460	593	711	373	900	–	500	250	900	500	250	1200	1200	500	1000
450Hp	8	435	Light	206...E395	479	–	411	900	–	550	275	1000	550	275	1300	1300	550	1000
		435	Normal	206...E435	479	639	411	900	–	500	250	900	500	250	1200	1200	500	1000
		425	Heavy	206...E510	638	765	401	900	–	550	275	1000	550	275	1300	1300	550	1000
500Hp	8	460	Light	206...E435	506	–	434	900	–	550	275	1000	550	275	1300	1300	550	1000
		510	Light	206...E460	561	–	481	900	–	650	325	1100	650	325	1500	1500	650	1000
		460	Normal	206...E460	506	711	434	900	–	550	275	1000	550	275	1300	1300	550	1000
550Hp	8	510	Normal	206...E510	561	765	481	900	–	650	325	1100	650	325	1500	1500	650	1000
500Hp	9	510	Light	206...E510	600	–	514	900	–	650	325	1200	650	325	1600	1600	650	1000
600Hp	9	595	Heavy	206...E630	893	1071	562	900	1000	600	300	1100	600	300	1400	1400	600	1000
		595	Normal	206...E595	655	918	562	900	1000	700	350	1300	700	350	1700	1700	700	1000
700Hp	9	630	Heavy	206...E760	945	1149	595	900	1000	750	375	1300	750	375	1800	1800	750	1000
		630	Normal	206...E630	693	1071	595	900	1000	750	375	1300	750	375	1800	1800	750	1000
750Hp	9	595	Light	206...E595	693	–	651	900	1000	800	400	1500	800	400	2000	2000	800	1000
		700	Heavy	206...E825	1050	1260	661	900	1000	850	425	1500	850	425	2000	2000	850	1000
800Hp	9	760	Heavy	206...E900	1140	1368	717	900	1000	900	450	1600	900	450	2200	2200	900	1000
		760	Normal	206...E760	836	1140	717	900	1000	900	450	1600	900	450	2200	2200	900	1000
		760	Light	206...E630	836	–	717	900	1000	900	450	1600	900	450	2200	2200	900	1000
810V DC Input																		
																		300
																		325
																		325
																		391
																		391
																		363
																		391
																		436
																		436
																		436
																		480
																		480
																		469
																		507
																		562
																		601
																		562
																		656
																		656
																		695
																		695
																		761
																		772
																		838
																		838
																		838

600V AC and 810V DC Input Protection Devices – Floor Mount Frames 8...10 (Continued)

Applied Rating (1)	Frame	Cont. Output [A]	Duty	Cat. No.	Output Overload [A]		Continuous AC Input	AC Input Integral Semiconductor Fuse Size (170M) (2)	DC Bay to Bay Integral Semiconductor Fuse Size (170M6648)	AC Input Protection Devices Recommended for Branch Circuit Protection (Does not apply to 21G Drives with Options)						DC Input Integral Semiconductor Fuse Size (170M6253) (7)			
					60 s	3 s				Dual-element Time-delay Fuse [A]		Non Time-delay Fuse [A]			Circuit Breaker [A]		Motor Circuit Protector (6)	Input Quantities	
										1/Phase Min (3)	2/Phase Min (3)	Max (4)	1/Phase Min (3)	2/Phase Min (3)	Max (4)				
600V AC Input																			
900 Hp	9	815	Heavy	206...E980	1223	1470	769	900	1000	950	475	1700	950	475	2300	2300	950	899	1000
		825	Normal	206...E825	908	1260	779	900	1000	950	475	1800	950	475	2300	2300	950	910	1000
		835	Light	206...E760	919	-	788	900	1000	1000	500	1800	1000	500	2400	2400	1000	921	1000
950 Hp	9	900	Normal	206...E900	990	1368	849	900	1000	1050	525	1900	1050	525	2500	2500	1050	993	1000
		900	Light	206...E825	990	-	849	900	1000	1050	525	1900	1050	525	2500	2500	1050	993	1000
1000 Hp	9	980	Normal	206...E980	1078	1470	925	900	1000	1150	575	2100	1150	575	2800	2800	1150	1081	1000
		980	Light	206...E900	1078	-	925	900	1000	1150	575	2100	1150	575	2800	2800	1150	1081	1000
	10	920	Heavy	206...E1K1	1380	1665	868	900	1000	1100	550	2000	1100	550	2600	2600	1100	1015	1000
1100 Hp	9	1045	Light	206...E980	1150	-	986	900	1000	1250	625	2200	1250	625	3000	3000	1250	1152	1000
	10	1110	Normal	206...E1K1	1221	1665	1048	900	1000	1300	650	2400	1300	650	3100	3100	1300	1224	1000
1200 Hp	10	1220	Light	206...E1K1	1342	1464	1151	900	1000	1450	725	2600	1450	725	3500	3500	1450	1345	1000
1250 Hp	10	1190	Heavy	206...E1K4	1785	2145	1123	900	1000	1400	700	2500	1400	700	3400	3400	1400	1312	1000
1400 Hp	10	1430	Normal	206...E1K4	1573	2145	1350	900	1000	1700	850	3000	1700	850	4100	4100	1700	1577	1000
1500 Hp	10	1530	Light	206...E1K4	1683	1836	1444	900	1000	1800	900	3200	1800	900	4300	4300	1800	1687	1000

(1) Applied rating refers to the motor that is connected to the drive. For example, a E420 drive can be used in Normal Duty mode on a 450 Hp motor, in Heavy Duty mode on a 350 Hp motor or in Light Duty mode on a 500 Hp motor. The drive can be programmed for each mode. Wiring and fuses can be sized based on the programmed mode. For any given drive catalog number, Normal Duty mode provides higher continuous current but smaller overload current when compared to Heavy Duty mode. See parameter 306 [Duty Rating].

(2) These AC line fuses (with blown fuse indicators) are included in the drive to provide drive short circuit protection. AC input protection devices for branch circuit protection based on US NEC are listed in the table. Each drive bay has one fuse per phase.

(3) Minimum protection device size is the lowest rated device that supplies maximum protection without nuisance tripping.

(4) Maximum protection device size is the highest rated device that supplies drive protection. For US NEC, minimum size is 125% of motor FLA. Ratings that are shown are maximum.

(5) Circuit breaker - inverse time breaker. For US NEC, minimum size is 125% of motor FLA. Ratings that are shown are maximum.

(6) Motor Protection Circuit Breaker - instantaneous trip circuit breaker. For US NEC, minimum size is 125% of motor FLA. Ratings that are shown are maximum.

(7) These DC line fuses (with blown fuse indicators) are included in the drive to provide drive short circuit protection.

690V AC and 932V DC Input Protection Devices – Wall Mount Frames 6 and 7

Applied Rating ⁽¹⁾	Frame	Cont. Output [A]	Drive Sized For Normal Duty				Drive Sized For Heavy Duty				Continuous AC Input [A]	AC Input Protection Devices						DC Input Protection Non-Time Delay Fuse	
			Output Overload [A]		Cat. No. (x = F or G)	3 s	Output Overload [A]		Cat. No. (x = F or G)	3 s		Dual Element Time Delay Fuse Min ⁽²⁾ [A]	Max ⁽⁵⁾ [A]	Non-Time Delay Fuse Min ⁽²⁾ [A]	Max ⁽⁵⁾ [A]	Circuit Breaker [A]	Max ⁽⁶⁾ [A]		Motor Circuit Protector [A] ⁽⁷⁾
			60 s	3 s			60 s	3 s											
690V AC Input																			
5.5 kW	6	9			20x...F011	13.5	18.0	8.4	11	19	11	25	30	15	HS115				
7.5 kW	6	12	20x...F011	13.2	18.0	20x...F015	18.0	22.5	11.2	25	14	35	40	15	HS120				
11 kW	6	15	20x...F015	16.5	22.5	20x...F020	22.5	30.0	14.1	32	18	40	50	20	HS125				
15 kW	6	20	20x...F020	22.0	30.0	20x...F023	30.0	36.0	18.7	42	23	55	60	25	HS135				
18.5 kW	6	23	20x...F023	25.3	34.5	20x...F030	34.5	45.0	21.6	48 ⁽³⁾ , 25 ⁽⁴⁾	27 ⁽³⁾ , 25 ⁽⁴⁾	65	70	30	HS140				
22 kW	6	30	20x...F030	33.0	45.0	20x...F034	45.0	54.0	28.1	65	35	85	90	40	HS150				
30 kW	6	34	20x...F034	37.4	51.0	20x...F046	51.0	69.0	31.9	70	40	95	100	40	HS160				
37 kW	6	46	20x...F046	50.6	69.0	20x...F050	69.0	82.8	43.1	95	55	130	130	55	HS180				
45 kW	6	50	20x...F050	55.0	75.0	20x...F061	75.0	91.5	46.9	105	60	140	150	60	HS190				
55 kW	6	61	20x...F061	67.1	91.5	20x...F082	91.5	123.0	57.2	130	70	170	180	75	HS1100				
75 kW	6	82	20x...F082	90.2	123.0	20x...F098	123.0	147.6	76.8	175	95	230	240	100	HS1150				
90 kW	6	98	20x...F098	107.8	147.0	20x...F119	147.0	178.5	91.8	205	115	275	280	115	HS1175				
110 kW	6	119	20x...F119	130.9	178.5	20x...F142	178.5	214.2	111.5	250	140	335	340	140	HS1200				
132 kW	6	142	20x...F142	156.2	213.0				133.1	300	165	400	400	170	HS1250				
	7	142			20x...F171	213.0	256.5	318.0	133.1	300	165	400	400	170	HS1250				
160 kW	7	171	20x...F171	188.1	256.5	20x...F212	256.5	318.0	160.2	360	200	480	490	205	HS1300				
200 kW	7	212	20x...F212	233.2	318.0	20x...F263	318.0	394.5	198.7	445	250	595	600	250	HS1350				
250 kW	7	263	20x...F263	289.3	394.5				246.5	555	310	740	740	310	HS1500				

(1) Applied rating refers to the motor that is connected to the drive. For example, a F061 drive can be used in Normal Duty mode on a 55 kW motor, in Heavy Duty mode on a 45 kW motor. The drive can be programmed for each mode. Wiring and fuses can be sized based on the programmed mode. For any given drive catalog number, Normal Duty mode provides higher continuous current but smaller overload current when compared to Heavy Duty mode. See parameter 306 [Duty Rating].

(2) Minimum protection device size is the lowest rated device that supplies maximum protection without nuisance tripping.

(3) Normal duty.

(4) Heavy duty.

(5) Maximum protection device size is the highest rated device that supplies drive protection. For US NEC, minimum size is 125% of motor FLA. Ratings that are shown are maximum.

(6) Circuit breaker – inverse time breaker. For US NEC, minimum size is 125% of motor FLA. Ratings that are shown are maximum.

(7) Motor Protection Circuit Breaker – instantaneous trip circuit breaker. For US NEC, minimum size is 125% of motor FLA. Ratings that are shown are maximum.

690V AC and 932V DC Input Protection Devices – Floor Mount Frames 8...10

Applied Rating (1)	Frame	Cont. Output [A]	Duty	Cat. No.	Output/Overload [A]		Continuous AC Input	AC Input Integral Semiconductor Fuse Size (170M)(2)	DC Bay to Bay Integral Semiconductor Fuse Size (170M6648)	AC Input Protection Devices Recommended for Branch Circuit Protection (Does not apply to 21G Drives with Options)						DC Input Integral Semiconductor Fuse Size (170M6253) (7)		
					60 s	3 s				Dual-element Time-delay Fuse [A]			Non Time-delay Fuse [A]				Circuit Breaker [A]	Motor Circuit Protector [A] (6)
										1/Phase Min (3)	2/Phase Min (3)	Max (4)	1/Phase Min (3)	2/Phase Min (3)	Max (4)			
690V AC Input																		
200 kW	8	215	Heavy	206...F265	323	375	203	900	–	250	125	500	250	125	600	600	250	1000
250 kW	8	265	Normal	206...F265	292	375	250	900	–	300	150	600	300	150	800	800	300	1000
		265	Heavy	206...F330	398	473	250	900	–	300	150	600	300	150	800	800	300	1000
300 kW	8	308	Heavy	206...F370	462	555	290	900	–	400	200	700	400	200	900	900	400	1000
315 kW	8	330	Light	206...F265	363	–	311	900	–	400	200	700	400	200	900	900	400	1000
		330	Normal	206...F330	363	473	311	900	–	400	200	700	400	200	900	900	400	1000
355 kW	8	370	Light	206...F330	407	–	349	900	–	450	225	800	450	225	1100	1100	450	1000
		370	Normal	206...F370	407	555	349	900	–	450	225	800	450	225	1100	1100	450	1000
		370	Heavy	206...F415	555	639	349	900	–	450	225	800	450	225	1100	1100	450	1000
375 kW	8	375	Heavy	206...F460	563	675	353	900	–	450	225	800	450	225	1100	1100	450	1000
400 kW	8	410	Light	206...F370	451	–	386	900	–	500	250	900	500	250	1200	1200	500	1000
		415	Normal	206...F415	457	639	391	900	–	500	250	900	500	250	1200	1200	500	1000
		413	Heavy	206...F500	620	750	389	900	–	500	250	900	500	250	1200	1200	500	1000
450 kW	8	460	Light	206...F415	506	–	433	900	–	550	275	1000	550	275	1300	1300	550	1000
		460	Normal	206...F460	506	675	433	900	–	550	275	1000	550	275	1300	1300	550	1000
500 kW	8	500	Light	206...F460	550	–	471	900	–	600	300	1100	600	300	1500	1500	600	1000
		500	Normal	206...F500	550	750	471	900	–	600	300	1100	600	300	1500	1500	600	1000
530 kW	8	530	Light	206...F500	583	–	499	900	–	650	325	1200	650	325	1500	1500	650	1000
450 kW	9	460	Heavy	206...F590	690	885	433	900	1000	550	275	1000	550	275	1300	1300	550	1000
500 kW	9	500	Heavy	206...F650	750	975	471	900	1000	600	300	1100	600	300	1400	1400	600	1000
560 kW	9	590	Heavy	206...F710	885	1065	556	900	1000	700	350	1300	700	350	1700	1700	700	1000
		590	Normal	206...F590	649	885	556	900	1000	700	350	1300	700	350	1700	1700	700	1000
630 kW	9	650	Heavy	206...F765	975	1170	612	900	1000	750	375	1400	750	375	1800	1800	750	1000
		650	Normal	206...F650	715	975	612	900	1000	750	375	1400	750	375	1800	1800	750	1000
710 kW	9	750	Light	206...F590	715	–	612	900	1000	750	375	1400	750	375	1800	1800	750	1000
		750	Heavy	206...F795	1125	1350	706	900	1000	900	450	1600	900	450	2100	2100	900	1000
		710	Normal	206...F710	781	1065	669	900	1000	900	450	1600	900	450	2100	2100	900	1000
750 kW	9	765	Light	206...F650	781	–	669	900	1000	900	450	1600	900	450	2100	2100	900	1000
800 kW	9	795	Normal	206...F765	842	1170	721	900	1000	900	450	1600	900	450	2200	2200	900	1000
		795	Heavy	206...F960	1193	1440	749	900	1000	950	475	1700	950	475	2200	2200	950	1000
		795	Normal	206...F795	875	1350	749	900	1000	950	475	1700	950	475	2200	2200	950	1000
		790	Light	206...F710	869	–	744	900	1000	950	475	1700	950	475	2200	2200	950	1000
850 kW	9	860	Light	206...F765	946	–	810	900	1000	1000	500	1800	1000	500	2400	2400	1000	1000

690V AC and 932V DC Input Protection Devices – Floor Mount Frames 8...10 (Continued)

Applied Rating (1)	Frame	Cont. Output [A]	Duty	Cat. No.	Output Overload [A]		Continuous AC Input	AC Input Integral Semiconductor Fuse Size (170M) (2)	DC Bay to Bay Integral Semiconductor Fuse Size (170M6648)	AC Input Protection Devices Recommended for Branch Circuit Protection (Does not apply to 21G Drives with Options)						DC Input Integral Semiconductor Fuse Size (170M6253) (7)						
					60 s	3 s				1/Phase Min (3)	2/Phase Min (3)	Max (4)	1/Phase Min (3)	2/Phase Min (3)	Max (4)		Circuit Breaker [A]	Motor Circuit Protector [A] (6)				
900 kW	9	960	Normal	206...F960	1440	1056	904	900	1000	690V AC Input						1000						
										1056	904	900	1000	1150	575		2000	1150	575	2700	2700	1150
														1056	904		900	1000	1150	575	2000	1150
1000 kW	10	865	Heavy	206...F1K0	1560	1298	815	900	1000	932V DC Input						1000						
										1122	904	900	1000	1200	600		2200	1200	600	2900	2900	1200
														1144	980		900	1000	1250	625	2200	1250
1100 kW	10	1150	Light	206...F1K0	1380	1265	1083	900	1000	932V DC Input						1000						
										1265	1083	900	1000	1350	675		2400	1350	675	3200	3200	1350
														1276	1093		900	1000	1350	675	2500	1350
1400 kW	10	1400	Normal	206...F1K4	2100	1540	1319	900	1000	932V DC Input						1000						
										1634	1399	900	1000	1650	825		3000	1650	825	4000	4000	1650
														1634	1782		900	1000	1750	875	3100	1750

- (1) Applied rating refers to the motor that is connected to the drive. For example, a F400 drive can be used in Normal Duty mode on a 400 kW motor, in Heavy Duty mode on a 355 kW motor or in Light Duty mode on a 450 kW motor. The drive can be programmed for each mode. Wiring and fuses can be sized based on the programmed mode. For any given drive catalog number, Normal Duty mode provides higher continuous current but smaller overload current when compared to Heavy Duty mode. See parameter 306 [Duty Rating].
- (2) These AC line fuses (with blown fuse indicators) are included in the drive to provide drive short circuit protection. AC input protection devices for branch circuit protection based on US NEC are listed in the table. Each drive bay has one fuse per phase.
- (3) Minimum protection device size is the lowest rated device that supplies maximum protection without nuisance tripping.
- (4) Maximum protection device size is the highest rated device that supplies drive protection. For US NEC, minimum size is 125% of motor F.L.A. Ratings that are shown are maximum.
- (5) Circuit breaker – inverse time breaker. For US NEC, minimum size is 125% of motor F.L.A. Ratings that are shown are maximum.
- (6) Motor Protection Circuit Breaker – instantaneous trip circuit breaker. For US NEC, minimum size is 125% of motor F.L.A. Ratings that are shown are maximum.
- (7) These DC line fuses (with blown fuse indicators) are included in the drive to provide drive short circuit protection.

Short Circuit Current Ratings for Drives with Options

Default ratings (no added protection) shown. A ‘•’ indicates ratings that can be achieved with additional protection.

400V AC Input

Drive Cat. No.	Frame	Duty Cycle	kW	Short Circuit Current Rating [kA]			
				Circuit Breaker Only (P3) ⁽¹⁾	Circuit Breaker with Input Contactor (P3 with P11) ⁽¹⁾	Molded Case Switch Only (P5) ⁽²⁾	Molded Case Switch with Input Contactor (P5 with P11) ⁽²⁾
21G...C460	8	LD	315	100	30	65 or • 100 with 700...800 A Class L fuse	5 or • 30 with 700...1200 A Class L fuse • 30 with 700...1200 A CB
		ND	250	100	30 or • 65 with 600 A Class J fuse	65	5 or • 65 with 600 A Class J fuse • 30 with 600...1000 A Class L fuse • 30 with 600...1200 A CB
		HD	200	100	5 or • 100 with 500...600 A Class J fuse • 18 with 600...800 A Class L fuse • 18 with 500 A CB	65	5 or • 100 with 500...600 A Class J fuse • 18 with 600...800 A Class L fuse • 18 with 500 A CB
21G...C540	8	LD	315	100	30	65 or • 100 with 750...800 A Class L fuse	5 or • 30 with 750...1300 A Class L fuse • 30 with 800...1200 A CB
		ND	315	100	30	65 or • 100 with 700...800 A Class L fuse	5 or • 30 with 700...1200 A Class L fuse • 30 with 700...1200 A CB
		HD	250	100	30 or • 65 with 600 A Class J fuse	65	5 or • 65 with 600 A Class J fuse • 30 with 600...1000 A Class L fuse • 30 with 600...1200 A CB
21G...C567	8	LD	355	100	30	65 or • 100 with 800 A Class L fuse	5 or • 30 with 800...1300 A Class L fuse • 30 with 800...1200 A CB
		ND	315	100	30	65 or • 100 with 750...800 A Class L fuse	5 or • 30 with 750...1200 A Class L fuse • 30 with 800...1200 A CB
		HD	250	100	30 or • 65 with 600 A Class J fuse	65	5 or • 65 with 600 A Class J fuse • 30 with 600...1000 A Class L fuse • 30 with 600...1200 A CB
21G...C650	8	LD	400	100	42	65 or • 100 with 1000...1200 A Class L fuse	5 or • 42 with 1000...1600 A Class L fuse • 42 with 1000...1200 A CB
		ND	355	100	42	65 or • 100 with 850...1200 A Class L fuse	5 or • 42 with 850...1400 A Class L fuse • 42 with 900...1200 A CB
		HD	315	100	30	65 or • 100 with 700...800 A Class L fuse	5 or • 30 with 700...1200 A Class L fuse • 30 with 700...1200 A CB
21G...C750	8	LD	450	100	42	65 or • 100 with 1000...1200 A Class L fuse	5 or • 42 with 1000...1700 A Class L fuse • 42 with 1000...1200 A CB
		ND	400	100	42	65 or • 100 with 1000...1200 A Class L fuse	5 or • 42 with 1000...1600 A Class L fuse • 42 with 1000...1200 A CB
		HD	315	100	30	65 or • 100 with 700...800 A Class L fuse	5 or • 30 with 750...1300 A Class L fuse • 30 with 800...1200 A CB
21G...C770	8	LD	450	100	42	65 or • 100 with 1000...1200 A Class L fuse	5 or • 42 with 1100...1800 A Class L fuse • 42 with 1100...1200 A CB
		ND	400	100	42	65 or • 100 with 1000...1200 A Class L fuse	5 or • 42 with 1000...1700 A Class L fuse • 42 with 1000...1200 A CB
		HD	355	100	42	65 or • 100 with 700...800 A Class L fuse	5 or • 42 with 800...1400 A Class L fuse • 42 with 800...1200 A CB

400V AC Input (Continued)

Drive Cat. No.	Frame	Duty Cycle	kW	Short Circuit Current Rating [kA]			
				Circuit Breaker Only (P3) ⁽¹⁾	Circuit Breaker with Input Contactor (P3 with P11) ⁽¹⁾	Molded Case Switch Only (P5) ⁽²⁾	Molded Case Switch with Input Contactor (P5 with P11) ⁽²⁾
21G...C910	9	LD	560	100			
		ND	500	100			
		HD	400	100			
21G...C1K0	9	LD	630	100			
		ND	560	100			
		HD	500	100			
21G...C1K1	9	LD	710	100			
		ND	630	100			
		HD	500	100			
21G...C1K2	9	LD	800	100			
		ND	710	100			
		HD	560	100			
21G...C1K4	9	LD	850	100			
		ND	800	100			
		HD	630	100			
21G...C1K5	9	LD	900	100			
		ND	850	100			
		HD	710	100			
21G...C1K6	10	LD	1000	—			
		ND	900	—			
		HD	710	—			
21G...C2K1	10	LD	1400	—			
		ND	1250	—			
		HD	1000	—			

(1) These circuit breakers are considered branch circuit protection for the unit.

(2) No additional protection is provided with the P5 molded case switch option. Branch circuit protection is required based on NEC guidelines.

480V AC Input

Drive Cat. No.	Frame	Duty Cycle	Hp	Short Circuit Current Rating [kA]			
				Circuit Breaker Only (P3) ⁽¹⁾	Circuit Breaker with Input Contactor (P3 with P11) ⁽¹⁾	Molded Case Switch Only (P5) ⁽²⁾	Molded Case Switch with Input Contactor (P5 with P11) ⁽²⁾
21G...D430	8	LD	400	100	30 or • 65 with 600 A Class J fuse	65	5 or • 65 with 600 A Class J fuse • 30 with 600...1000 A Class L fuse • 30 with 600...1200 A CB
		ND	350	100	30 or • 65 with 550...600 A Class J fuse	65	30 or • 65 with 550...600 A Class J fuse
		HD	300	100	5 or • 100 with 450...600 A Class J fuse • 18 with 600...800 A Class L fuse • 18 with 500 A CB	65	5 or • 100 with 500...600 A Class J fuse • 18 with 600...800 A Class L fuse • 18 with 500 A CB
21G...D485	8	LD	450	100	30	65 or • 100 with 800 A Class L fuse	5 or • 30 with 650...1200 A Class L fuse • 30 with 700...1200 A CB
		ND	400	100	30 or • 65 with 600 A Class J fuse	65	5 or • 65 with 600 A Class J fuse • 30 with 600...1000 A Class L fuse • 30 with 600...1200 A CB
		HD	350	100	5 or • 100 with 500...600 A Class J fuse • 18 with 600...900 A Class L fuse	65	5 or • 100 with 500...600 A Class J fuse • 18 with 600...900 A Class L fuse
21G...D545	8	LD	500	100	30	65 or • 100 with 800 A Class L fuse	5 or • 30 with 700...1300 A Class L fuse • 30 with 700...1200 A CB
		ND	450	100	30	65 or • 100 with 650...800 A Class L fuse	5 or • 30 with 650...1200 A Class L fuse • 30 with 700...1200 A CB
		HD	350	100	30 or • 65 with 550...600 A Class J fuse	65	5 or • 65 with 550...600 A Class J fuse • 30 with 600...1000 A Class L fuse • 30 with 600...1200 A CB

480V AC Input (Continued)

Drive Cat. No.	Frame	Duty Cycle	Hp	Short Circuit Current Rating [kA]			
				Circuit Breaker Only (P3) ⁽¹⁾	Circuit Breaker with Input Contactor (P3 with P11) ⁽¹⁾	Molded Case Switch Only (P5) ⁽²⁾	Molded Case Switch with Input Contactor (P5 with P11) ⁽²⁾
21G...D617	8	LD	600	100	42	65 or • 100 with 850...1200 A Class L fuse	5 or • 42 with 850...1500 A Class L fuse • 42 with 900...1200 A CB
		ND	500	100	30	65 or • 100 with 750...800 A Class L fuse	5 or • 30 with 750...1300 A Class L fuse • 30 with 800...1200 A CB
		HD	400	100	30 or • 65 with 600 A Class J fuse	65	5 or • 65 with 600 A Class J fuse • 30 with 600...1000 A Class L fuse • 30 with 600...1200 A CB
21G...D710	8	LD	650	100	42	65 or • 100 with 1000...1200 A Class L fuse	5 or • 42 with 1000...1700 A Class L fuse • 42 with 1000...2000 A CB
		ND	600	100	42	65 or • 100 with 850...1200 A Class L fuse	5 or • 42 with 850...1500 A Class L fuse • 42 with 900...1200 A CB
		HD	450	100	30	65 or • 100 with 650...800 A Class L fuse	5 or • 30 with 650...1200 A Class L fuse • 30 with 700...1200 A CB
21G...D740	8	LD	700	100	42	65 or • 100 with 1000...1200 A Class L fuse	5 or • 42 with 1000...1700 A Class L fuse • 42 with 1000...2000 A CB
		ND	650	100	42	65 or • 100 with 900...1200 A Class L fuse	5 or • 42 with 900...1600 A Class L fuse • 42 with 900...2000 A CB
		HD	500	100	30	65 or • 100 with 750...800 A Class L fuse	5 or • 30 with 750...1300 A Class L fuse • 30 with 800...1200 A CB
21G...D800	9	LD	800	100			
		ND	700	100			
		HD	600	100			
21G...D960	9	LD	900	100			
		ND	800	100			
		HD	700	100			
21G...D1K0	9	LD	1000	100			
		ND	900	100			
		HD	750	100			
21G...D1K2	9	LD	1100	100			
		ND	1000	100			
		HD	800	100			
21G...D1K3	9	LD	1250	100			
		ND	1100	100			
		HD	900	100			
21G...D1K4	9	LD	1350	100			
		ND	1250	100			
		HD	1000	100			
21G...D1K5	10	LD	1500	—			
		ND	1350	—			
		HD	1100	—			
21G...D2K0	10	LD	2000	—			
		ND	1750	—			
		HD	1650	—			

(1) These circuit breakers are considered branch circuit protection for the unit.

(2) No additional protection is provided with the P5 molded case switch option. Branch circuit protection is required based on NEC guidelines.

600V AC Input

Drive Cat. No.	Frame	Duty Cycle	Hp	Short Circuit Current Rating [kA]			
				Circuit Breaker Only (P3) ⁽¹⁾	Circuit Breaker with Input Contactor (P3 with P11) ⁽¹⁾	Molded Case Switch Only (P5) ⁽²⁾	Molded Case Switch with Input Contactor (P5 with P11) ⁽²⁾
21G...E295	8	LD	350	50	<ul style="list-style-type: none"> • 18 with 601...700 A Class L fuse • 18 with 500 A CB • 100 with 600 A Class J fuse 	25	<ul style="list-style-type: none"> • 25 with 600 A Class J fuse
		ND	300	50	<ul style="list-style-type: none"> • 18 with 600 A Class L fuse • 18 with 500 A CB • 100 with 600 A Class J fuse 	25	<ul style="list-style-type: none"> • 25 with 600 A Class J fuse
		HD	250	50	<ul style="list-style-type: none"> • 18 with 600 A Class L fuse • 18 with 500 A CB • 100 with 600 A Class J fuse 	25	<ul style="list-style-type: none"> • 25 with 600 A Class J fuse
21G...E355	8	LD	400	50	<ul style="list-style-type: none"> • 18 with 601...800 A Class L fuse • 18 with 500 A CB • 100 with 600 A Class J fuse 	25	<ul style="list-style-type: none"> • 25 with 600 A Class J fuse
		ND	350	50	<ul style="list-style-type: none"> • 18 with 601...700 A Class L fuse • 18 with 500 A CB • 100 with 600 A Class J fuse 	25	<ul style="list-style-type: none"> • 25 with 600 A Class J fuse
		HD	300	50	<ul style="list-style-type: none"> • 18 with 600 A Class L fuse • 18 with 500 A CB • 100 with 600 A Class J fuse 	25	<ul style="list-style-type: none"> • 25 with 600 A Class J fuse
21G...E395	8	LD	450	50	<ul style="list-style-type: none"> • 30 with 601...900 A Class L fuse • 30 with 1000 A CB 	<ul style="list-style-type: none"> • 100 with 800 A max Class L fuse 	<ul style="list-style-type: none"> • 30 with 800 A Class L fuse
		ND	400	50	<ul style="list-style-type: none"> • 18 with 601...800 A Class L fuse • 18 with 500 A CB • 100 with 600 A Class J fuse 	25	<ul style="list-style-type: none"> • 25 with 600 A Class J fuse
		HD	350	50	<ul style="list-style-type: none"> • 18 with 601...700 A Class L fuse • 18 with 500 A CB • 100 with 600 A Class J fuse 	25	<ul style="list-style-type: none"> • 25 with 600 A Class J fuse
21G...E435	8	LD	500	50	<ul style="list-style-type: none"> • 30 with 601...1000 A Class L fuse • 30 with 1000 A CB 	<ul style="list-style-type: none"> • 100 with 800 A max Class L fuse 	<ul style="list-style-type: none"> • 30 with 800 A Class L fuse
		ND	450	50	<ul style="list-style-type: none"> • 30 with 601...900 A Class L fuse • 30 with 1000 A CB 	<ul style="list-style-type: none"> • 100 with 800 A max Class L fuse 	<ul style="list-style-type: none"> • 30 with 800 A Class L fuse
		HD	350	50	<ul style="list-style-type: none"> • 18 with 601...700 A Class L fuse • 18 with 500 A CB • 100 with 600 A Class J fuse 	25	<ul style="list-style-type: none"> • 25 with 600 A Class J fuse
21G...E460	8	LD	500	35	<ul style="list-style-type: none"> • 30 with 601...1000 A Class L fuse • 30 with 1000 A CB 	<ul style="list-style-type: none"> • 100 with 800 A max Class L fuse 	<ul style="list-style-type: none"> • 30 with 800 A Class L fuse
		ND	500	50	<ul style="list-style-type: none"> • 30 with 601...1000 A Class L fuse • 30 with 1000 A CB 	<ul style="list-style-type: none"> • 100 with 800 A max Class L fuse 	<ul style="list-style-type: none"> • 30 with 800 A Class L fuse
		HD	400	50	<ul style="list-style-type: none"> • 18 with 601...800 A Class L fuse • 18 with 500 A CB • 100 with 600 A Class J fuse 	25	<ul style="list-style-type: none"> • 25 with 600 A Class J fuse
21G...E510	8	LD	550	35	<ul style="list-style-type: none"> • 30 with 601...1100 A Class L fuse • 30 with 1100 A CB 	<ul style="list-style-type: none"> • 100 with 800 A max Class L fuse 	<ul style="list-style-type: none"> • 30 with 800 A Class L fuse
		ND	500	35	<ul style="list-style-type: none"> • 30 with 601...1000 A Class L fuse • 30 with 1000 A CB 	<ul style="list-style-type: none"> • 100 with 800 A max Class L fuse 	<ul style="list-style-type: none"> • 30 with 800 A Class L fuse
		HD	450	50	<ul style="list-style-type: none"> • 30 with 601...900 A Class L fuse • 30 with 1000 A CB 	<ul style="list-style-type: none"> • 100 with 800 A max Class L fuse 	<ul style="list-style-type: none"> • 30 with 800 A Class L fuse
21G...E595	9	LD	700	50			
		ND	600	50			
		HD	500	50			

600V AC Input (Continued)

Drive Cat. No.	Frame	Duty Cycle	Hp	Short Circuit Current Rating [kA]			
				Circuit Breaker Only (P3) ⁽¹⁾	Circuit Breaker with Input Contactor (P3 with P11) ⁽¹⁾	Molded Case Switch Only (P5) ⁽²⁾	Molded Case Switch with Input Contactor (P5 with P11) ⁽²⁾
21G...E630	9	LD	800	50			
		ND	700	50			
		HD	600	50			
21G...E760	9	LD	900	50			
		ND	800	50			
		HD	700	50			
21G...E825	9	LD	950	50			
		ND	900	50			
		HD	750	50			
21G...E900	9	LD	1000	65			
		ND	950	50			
		HD	800	50			
21G...E980	9	LD	1100	65			
		ND	1000	65			
		HD	900	50			
21G...E1K1	10	LD	1220	—			
		ND	1100	—			
		HD	1000	—			
21G...E1K4	10	LD	1500	—			
		ND	1400	—			
		HD	1250	—			

(1) These circuit breakers are considered branch circuit protection for the unit if the tap is within 10 ft of the breaker input.

(2) These switches are 21G, SCCR ratings, with no additional protection provided. Branch circuit protection (fuse) is required based on NEC guidelines for options with P5.

690V AC Input

Drive Cat. No.	Frame	Duty Cycle	kW	Short Circuit Current Rating [kA]			
				Circuit Breaker Only (P3) ⁽¹⁾	Circuit Breaker with Input Contactor (P3 with P11) ⁽¹⁾	Molded Case Switch Only (P5) ⁽²⁾	Molded Case Switch with Input Contactor (P5 with P11) ⁽²⁾
21G...F265	8	LD	315	30	SCCR rating for 690V input contactor not available at time of publication.	25	SCCR rating for 690V input contactor not available at time of publication.
		ND	250	30		25	
		HD	200	30		25	
21G...F330	8	LD	355	30			
		ND	315	30		25	
		HD	250	30		25	
21G...F370	8	LD	400	30			
		ND	355	30		25	
		HD	300	30		25	
21G...F415	8	LD	450	30			
		ND	400	30		25	
		HD	355	30		25	
21G...F460	8	LD	500	25			
		ND	450	30		25	
		HD	375	30		25	
21G...F500	8	LD	530	25			
		ND	500	25		25	
		HD	400	30		25	

690V AC Input (Continued)

Drive Cat. No.	Frame	Duty Cycle	kW	Short Circuit Current Rating [kA]			
				Circuit Breaker Only (P3) ⁽¹⁾	Circuit Breaker with Input Contactor (P3 with P11) ⁽¹⁾	Molded Case Switch Only (P5) ⁽²⁾	Molded Case Switch with Input Contactor (P5 with P11) ⁽²⁾
21G...F590	9	LD	630	35			
		ND	560	35			
		HD	450	35			
21G...F650	9	LD	710	35			
		ND	630	35			
		HD	500	35			
21G...F710	9	LD	800	35			
		ND	710	35			
		HD	560	35			
21G...F765	9	LD	850	35			
		ND	750	35			
		HD	630	35			
21G...F795	9	LD	900	35			
		ND	800	35			
		HD	710	35			
21G...F960	9	LD	1000	35			
		ND	900	35			
		HD	800	35			
21G...F1K0	10	LD	1100	—			
		ND	1000	—			
		HD	900	—			
21G...F1K4	10	LD	1500	—			
		ND	1400	—			
		HD	1120	—			

(1) These circuit breakers are considered branch circuit protection for the unit if the tap is within 10 ft of the breaker input.

(2) These switches are 21G, SCCR ratings, with no additional protection provided. Branch circuit protection (fuse) is required based on NEC guidelines for options with P5.

Cable Considerations

This section provides information for cable types and routing.

Power Cable Types Acceptable for 200...600 Volt Installations

Various cable types are acceptable for drive installations. For an in-depth discussion of cable types, including a table of maximum motor cable lengths, see the Wiring and Grounding Guidelines for Pulse Width Modulated (PWM) AC Drives, publication [DRIVES-IN001](#).

Recommended Cable Design

Rating/Type	Description
600V 75 °C (167 °F)	<ul style="list-style-type: none"> Four tinned copper conductors with XLPE insulation. Copper braid/aluminum foil combination shield and tinned copper drain wire. PVC jacket.

Wiring Considerations

This section provides information for power, signal, and I/O wiring.

Type	Wire Types	Description	Min Insulation Rating	
Power ^{(1) (2)}	Standard	-	• Four tinned copper conductors with XLPE insulation. • Copper braid/aluminum foil combination shield and tinned copper drain wire. • PVC jacket.	600V, 75 °C (167 °F)
	Standard analog I/O	-	0.750 mm ² (18 AWG), twisted pair, 100% shield with drain.	300V, 75...90 °C (167...194 °F)
Signal ^{(1) (3) (4)}	Remote pot	-	0.750 mm ² (18 AWG), 3 conductor, shielded.	
	Encoder/ Pulse I/O <30 m (100 ft)	Combined	0.196 mm ² (24 AWG) individually shielded pairs.	
	Encoder/ Pulse I/O 30...152 m (100...500 ft)	Signal	0.196 mm ² (24 AWG) individually shielded pairs.	
		Power	0.750 mm ² (18 AWG) individually shielded pairs	
		Combined	0.330 mm ² (22 AWG), power is 0.500 mm ² (20 AWG) individually shielded pairs.	
	Encoder/ Pulse I/O 152...259 m (500...850 ft)	Signal	0.196 mm ² (24 AWG) individually shielded pairs.	
		Power	0.750 mm ² (18 AWG) individually shielded pairs.	
		Combined	0.750 mm ² (18 AWG) individually shielded pairs.	
Digital I/O Safety inputs Homing inputs ^{(1) (3) (4)}	Unshielded	-	Per US NEC or applicable national or local code.	
	Shielded	Multi-conductor shielded cable	0.750 mm ² (18 AWG), 3 conductor, shielded.	

- (1) Separate control and signal wires from power wires by at least 0.3 m (1 ft).
- (2) The use of shielded wire for AC input power is not always necessary, but is recommended.
- (3) If the wires are short and contained within a cabinet that has no sensitive circuits, the use of shielded wire is not always necessary, but is recommended.
- (4) I/O terminals that are labeled (-) or common are not referenced to earth ground and are designed to reduce common mode interference. Grounding these terminals can cause signal noise. For CE installations, 115V I/O must use shielded cable or have a cable length less than 30 m (98 ft).

Power Wiring Options

This section describes the cabling options available for each Frame 8...10 drive enclosure. See pages [148...177](#) for conduit plate dimensions.



Adequate Spacing
Available conduit plates provide adequate spacing for typical cabling.



Possible - Evaluation is Required
Available conduit plates must be evaluated to determine if cabling fits.



Not Possible - Insufficient Spacing
Conduit plates are not available for the specified configuration.

Cable Entry and Exit Routes

Frame	Enclosure Rating	Enclosure Code	Cabinet Layout	Top Entry/ Top Exit	Top Entry/ Bottom Exit	Bottom Entry/ Top Exit	Bottom Entry/ Bottom Exit
8	IP20, NEMA/UL Type 1	B	600 mm drive cabinet	X		X	0
		L, P, W	800 mm drive cabinet	0		0	
		B	600 mm drive with power option bay			X	0
		L, P, W	800 mm drive with power option bay			0	
		B	600 mm drive with wiring bay				
		L, P, W	800 mm drive with wiring bay				
		B	600 mm drive with power option and wiring bays				
		L, P, W	800 mm drive with power option bay and wiring bays				
	IP54, NEMA 12	J, K, Y	800 mm drive cabinet	X	X	X	
		J, K, Y	800 mm drive with power option bay	X		0	0
		J, K, Y	800 mm drive with wiring bay				
		J, K, Y	800 mm drive with power option bay and wiring bays				
9	IP20, NEMA/UL Type 1	B	600 mm drive cabinet	0		0	0
		L, P, W	800 mm drive cabinet				
		B	600 mm drive with power option bay			X	
		L, P, W	800 mm drive with power option bay			0	
		B	600 mm drive with wiring bay				
		L, P, W	800 mm drive with wiring bay				
		B	600 mm drive with power option and wiring bays				
		L, P, W	800 mm drive with power option bay and wiring bays				
	IP54, NEMA 12	J, K, Y	800 mm drive cabinet	X	X	X	
		J, K, Y	800 mm drive with power option bay	0		0	
		J, K, Y	800 mm drive with wiring bay				
		J, K, Y	800 mm drive with power option bay and wiring bays				
10	IP20, NEMA/UL Type 1	B	600 mm drive cabinet	0		0	0
		L, P, W	800 mm drive cabinet			0	
		B	600 mm drive with power option bay	X		X	
		L, P, W	800 mm drive with power option bay	0		0	
		B	600 mm drive with wiring bay				
		L, P, W	800 mm drive with wiring bay				
		B	600 mm drive with power option and wiring bays				
		L, P, W	800 mm drive with power option bay and wiring bays			X	
	IP54, NEMA 12	J, K, Y	800 mm drive cabinet	X	X	X	
		J, K, Y	800 mm drive with power option bay	X	0	0	
		J, K, Y	800 mm drive with wiring bay	0			
		J, K, Y	800 mm drive with power option bay and wiring bays				

Motor Considerations

Due to the operational characteristics of AC variable frequency drives, we recommend motors with inverter grade insulation systems that are designed to meet or exceed NEMA MG1 Part 31.40.4.2 standards for resistance to spikes of 1600 volts.

Guidelines must be followed when using non-inverter grade motors to avoid premature motor failures. See Wiring and Grounding Guidelines for Pulse Width Modulated (PWM) AC Drives, publication [DRIVES-IN001](#) for recommendations.

Allen-Bradley Permanent Magnet Servo Motors

When using a PowerFlex 755 drive to control a permanent magnet motor, the motor feedback device must have a resolution such that the number of pulses per revolution (PPR) is an exponent of 2 (for example: 512, 1024, 2048, 4096, 8192, and so on).

The following table contains a list of specifications for Allen-Bradley® servo motors compatible with PowerFlex 750-Series drives. This information is provided to help configure a PowerFlex 750-Series drive with the appropriate servo motor data. For information about compatibility and configuration of Allen-Bradley servo motors (including Bulletin RDB or RDD-Series™ Direct Drive motors) and third-party PM motors, contact Rockwell Automation technical support.

Allen-Bradley Servo Motors Compatible with PowerFlex 750-Series Drives

Cat. No.	Motor NP Volts (line-line V rms)	Motor NP Amps (A rms)	Motor NP Hertz (Hz)	Motor NP RPM (oper. rpm)	Motor NP Power (kW)	Motor Poles	Current peak (A rms)	System Cont. Stall Torque (N·m)	Motor Max RPM
MPL-B4530K	460	7.8	200.7	3010	2.6	8	19.1	8.25	4000
MPL-B4560F	460	8.3	144.7	2170	3.2	8	25.5	14.1	3000
MPL-B520K	460	8.1	208	3120	3.5	8	23.3	10.7	4000
MPL-B540K	460	14.5	177.3	2660	5.4	8	42.4	19.4	4000
MPL-B560F	460	14.5	130.7	1960	5.5	8	42.4	26.8	3000
MPL-B580F	460	18.4	132.7	1990	7.1	8	66.5	34	3000
MPL-B580J	460	22.6	148	2220	7.9	8	66.5	34	3800
MPL-B640F	460	22.7	106	1590	6.11	8	46	36.7	3000
MPL-B660F	460	27.2	81.3	1220	6.15	8	67.9	48	3000
MPL-B680D	460	24	94	1410	9.3	8	66.5	62.8	2000
MPL-B680F	460	33.9	79.3	1190	7.5	8	67.9	60	3000
MPL-B860D	460	33.6	96	1440	12.5	8	67.5	83.1	2000
MPL-B880C	460	33.6	72.7	1090	12.6	8	69	110	1500
MPL-B880D	460	40.3	86.7	1300	15	8	113.2	110	2000
MPL-B960B	460	29.7	62	930	12.7	8	63.6	130	1200
MPL-B960C	460	38.9	76	1140	14.8	8	88.4	124.3	1500
MPL-B960D	460	50.2	76.7	1150	15	8	102.5	124.3	2000
MPL-B980B	460	31.8	59.3	890	15.02	8	70.7	162.7	1000
MPL-B980C	460	48.2	67.3	1010	16.8	8	99	158.2	1500
MPL-B980D	460	63.6	74.7	1120	18.6	8	141.4	158.2	2000
MPM-B1151F	480	1.5	266.7	4000	0.75	8	7	2.18	5000
MPM-B1151T	480	3.1	333.3	5000	0.9	8	14.5	2.18	7000
MPM-B1152C	480	2.3	166.7	2500	1.2	8	8.8	2.18	3000
MPM-B1152F	480	2.9	266.7	4000	1.4	8	15.5	4.74	5200
MPM-B1152T	480	5.2	266.7	4000	1.4	8	26.8	4.74	7000
MPM-B1153E	480	2.7	200	3000	1.4	8	15.3	6.55	3500
MPM-B1153F	480	3.2	266.7	4000	1.45	8	22.6	6.55	5500
MPM-B1153T	480	5.5	266.7	4000	1.45	8	39.2	6.55	7000
MPM-B1302F	480	3.4	266.7	4000	1.65	8	15.6	5.99	4500
MPM-B1302M	480	4.9	266.7	4000	1.65	8	22.6	5.99	6000
MPM-B1302T	480	6.6	266.7	4000	1.65	8	30.7	5.99	7000
MPM-B1304C	480	3.4	183.3	2750	2	8	15.8	10.2	2750
MPM-B1304E	480	4.1	166.7	2500	2.2	8	24.2	10.2	4000
MPM-B1304M	480	7.3	233.3	3500	2.2	8	42.9	10.2	6000

Allen-Bradley Servo Motors Compatible with PowerFlex 750-Series Drives (Continued)

Cat. No.	Motor NP Volts (line-line V rms)	Motor NP Amps (A rms)	Motor NP Hertz (Hz)	Motor NP RPM (oper. rpm)	Motor NP Power (kW)	Motor Poles	Current peak (A rms)	System Cont. Stall Torque (N•m)	Motor Max RPM
MPM-B1651C	480	4.7	200	3000	2.5	8	20.6	10.7	3500
MPM-B1651F	480	8.2	200	3000	2.5	8	36	10.7	5000
MPM-B1651M	480	10.9	200	3000	2.5	8	40.2	10.7	5000
MPM-B1652C	480	7	166.7	2500	3.8	8	23.8	16	2500
MPM-B1652E	480	8	233.3	3500	4.3	8	42.8	19.4	3500
MPM-B1652F	480	11	233.3	3500	4.3	8	59.5	19.4	4500
MPM-B1653C	480	10.5	133.3	2000	4.6	8	41.9	26.8	2500
MPM-B1653E	480	10.2	200	3000	5.1	8	51.6	26.8	3500
MPM-B1653F	480	13.2	200	3000	5.1	8	66.7	26.8	4000
MPM-B2152C	480	12.3	133.3	2000	5.6	8	39.2	36.7	2500
MPM-B2152F	480	18.7	166.7	2500	5.9	8	69.3	33	4500
MPM-B2152M	480	21	166.7	2500	5.9	8	54	30	5000
MPM-B2153B	480	12.7	116.7	1750	6.8	8	42.4	48	2000
MPM-B2153E	480	19.3	133.3	2000	7.2	8	69.7	48	3000
MPM-B2153F	480	22.1	133.3	2000	7.2	8	69.6	45	3800
MPM-B2154B	480	13.9	116.7	1750	6.9	8	69.3	62.8	2000
MPM-B2154e	480	18.3	133.3	2000	7.5	8	69.5	56	3000
MPM-B2154F	480	19.8	133.3	2000	7.5	8	59.3	56	3300

For motor power and feedback cable information, see the Kinetix® Motion Control Selection Guide, publication [KNX-SG001](#).

Dimensions and Weights

This section provides Frame and rating cross-references.

208V AC and 240V AC

Cat. No.	Light Duty kW Output	Normal Duty kW Output	Heavy Duty kW Output	Cat. No.	Light Duty Hp Output	Normal Duty Hp Output	Heavy Duty Hp Output	Enclosure Code/Frame Size			
								F	G	N	R
208 Volt				240 Volt							
20x...B2P2		0.37 (0.37) ⁽¹⁾	0.37 (0.37) ⁽¹⁾	20x...B2P2	-	0.5(0.5) ⁽¹⁾	0.5(0.5) ⁽¹⁾	2	2	2	1
20x...B4P2	-	0.75(0.75) ⁽¹⁾	0.75(0.37) ⁽¹⁾	20x...B4P2	-	1(1) ⁽¹⁾	1(0.5) ⁽¹⁾				
20x...B6P8	-	1.5(1.5) ⁽¹⁾	1.5(0.75) ⁽¹⁾	20x...B6P8	-	2(2) ⁽¹⁾	2(1) ⁽¹⁾				
20x...B9P6	-	2.2(2.2) ⁽¹⁾	2.2(1.5) ⁽¹⁾	20x...B9P6	-	3 (3) ⁽¹⁾	3(2) ⁽¹⁾				
20x...B015	-	4(4) ⁽¹⁾	2.2(2.2) ⁽¹⁾	20x...B015	-	5(5) ⁽¹⁾	3 (3) ⁽¹⁾				
20x...B022	-	5.5	4	20x...B022	-	7.5	5	3	3	3	
20x...B028	-	7.5	5.5	20x...B028	-	10	7.5				
20x...B042	-	11	7.5	20x...B042	-	15	10				
20x...B054	-	15	11	20x...B054	-	20	15	4	4	4	
20x...B070	-	18.5	15	20x...B070	-	25	20	5	5	5	
20x...B080	-	22	18.5	20x...B080	-	30	25				
20x...B104	-	30	22	20x...B104	-	40	30	6 ⁽²⁾	6	6	
20x...B130	-	37	30	20x...B130	-	50	40				
20x...B154	-	45	37	20x...B154	-	60	50				
20x...B192	-	55	45	20x...B192	-	75	60				
20x...B260	-	66	55	20x...B260	-	100	75				
20x...B312	-	90	66	20x...B312	-	125	100	7 ⁽²⁾	7	7	
20x...B360	-	110	90	20x...B360	-	150	125				
20x...B477	-	132	90	20x...B477	-	200	125				

(1) Ratings in parenthesis are only applicable for Frame 1.

(2) For Frames 6 and 7, a user-installed flange kit (catalog number 20-750-FLNG4-Fx) is available to convert a code N drive that provides a NEMA/UL Type 4X/12 back.

400V AC and 480V AC

Cat. No.	Light Duty kW Output	Normal Duty kW Output	Heavy Duty kW Output	Cat. No.	Light Duty Hp Output	Normal Duty Hp Output	Heavy Duty Hp Output	Enclosure Code/Frame Size												
								B, J, L, T	F	G	N	K, P, W, Y	R							
400 Volt				480 Volt																
20x...C2P1	-	0.75 (0.75) ⁽¹⁾	0.75 (0.37) ⁽¹⁾	20x...D2P1	-	1(1) ⁽¹⁾	1(0.5) ⁽¹⁾													
20x...C3P5	-	1.5 (1.5) ⁽¹⁾	1.5 (0.75) ⁽¹⁾	20x...D3P4	-	2(2) ⁽¹⁾	2(1.5) ⁽¹⁾													
20x...C5P0	-	2.2 (2.2) ⁽¹⁾	2.2 (1.5) ⁽¹⁾	20x...D5P0	-	3(3) ⁽¹⁾	3(2) ⁽¹⁾													
20x...C8P7	-	4 (4) ⁽¹⁾	4 (2.2) ⁽¹⁾	20x...D8P0	-	5 (5) ⁽¹⁾	5 (3) ⁽¹⁾													
20x...C011	-	5.5 (5.5) ⁽¹⁾	5.5 (4) ⁽¹⁾	20x...D011	-	7.5 (7.5) ⁽¹⁾	7.5 (5) ⁽¹⁾													
20x...C015	-	7.5 (7.5) ⁽¹⁾	5.5 (5.5) ⁽¹⁾	20x...D014	-	10 (10) ⁽¹⁾	7.5 (7.5) ⁽¹⁾													
20x...C022	-	11	7.5	20x...D022	-	15	10													
20x...C030	-	15	11	20x...D027	-	20	15													
20x...C037	-	18.5	15	20x...D034	-	25	20													
20x...C043	-	22	18.5	20x...D040	-	30	25													
20x...C060	-	30	22	20x...D052	-	40	30													
20x...C072	-	37	30	20x...D065	-	50	40													
20x...C085	-	45	37	20x...D077	-	60	50													
20x...C104	-	55	45	20x...D096	-	75	60													
20x...C140	-	75	55	20x...D125	-	100	75													
20x...C170	-	90	75	20x...D156	-	125	100													
20x...C205	-	110	90	20x...D186	-	150	125													
20x...C260	-	132	110	20x...D248	-	200	150													
20x...C302	-	160	132	20x...D302	-	250	200													
20x...C367	-	200	160	20x...D361	-	300	250													
20x...C456	-	250	200	20x...D415	-	350	300													
2xG...C460	315	250	200	20x...D430	400	350	300	8	-	-	-	-	8							
2xG...C477	-	270	200	20x...D477	-	400	300	-	7 ⁽²⁾	-	-	7	-							
2xG...C540	315	315	250	20x...D485	450	400	350													
2xG...C567	355	315	250	20x...D545	500	450	350													
2xG...C650	400	355	315	20x...D617	600	500	400	8												
2xG...C750	450	400	355	20x...D710	650	600	450													
2xG...C770	450	400	355	20x...D740	700	650	500													
2xG...C910	560	500	400	20x...D800	800	700	600													
2xG...C1K0	630	560	500	20x...D960	900	800	700													
2xG...C1K1	710	630	500	20x...D1K0	1000	900	750													
2xG...C1K2	800	710	560	20x...D1K2	1100	1000	800	9												
2xG...C1K4	850	800	630	20x...D1K3	1250	1100	900													
2xG...C1K5	900	850	710	20x...D1K4	1350	1250	1000													
2xG...C1K6	1000	900	710	20x...D1K5	1500	1350	1100													
2xG...C2K1	1400	1250	1000	20x...D2K0	2000	1750	1650	10												

(1) Ratings in parenthesis are only applicable for Frame 1.

(2) For Frames 6 and 7, a user-installed flange kit (catalog number 20-750-FLNG4-Fx) is available to convert a code N drive that provides a NEMA/UL Type 4X/12 back.

600V AC and 690V AC

Cat. No.	Light Duty kW Output	Normal Duty kW Output	Heavy Duty kW Output	Cat. No.	Light Duty Hp Output	Normal Duty Hp Output	Heavy Duty Hp Output	Enclosure Code/Frame Size						
								B, J, L, T	F		G, N		K, P, W, Y	R
									690V	600V	690V	600V		
690 Volt				600 Volt										
				20x...E1P7	-	1	0.5							
				20x...E2P7	-	2	1							
				20x...E3P9	-	3	2			3	-	3		
				20x...E6P1	-	5	3							
				20x...E9P0	-	7.5	5							
				20x...E011	-	10	7.5							
20x...F012	-	7.5	5.5	20x...E012	-	10	7.5			-	6	6		
				20x...E017	-	15	10			3	-	3		
20x...F015	-	11	7.5	20x...E018	-	15	10			-	6	6		
				20x...E022	-	20	15			3	-	3		
20x...F020	-	15	11	20x...E023	-	20	15			-	6	6		
20x...F023	-	18.5	15	20x...E024	-	20	20			-	6	6		
				20x...E027	-	25	20			4	-	4		
20x...F030	-	22	18.5	20x...E028	-	25	20			-	6	6		
				20x...E032	-	30	25			4	-	4		
20x...F034	-	30	22	20x...E033	-	30	25			-	6	6		
				20x...E041	-	40	30			5	-	5		
20x...F046	-	37	30	20x...E042	-	40	30			-	6	6		
				20x...E052	-	50	40			5	-	5		
20x...F050	-	45	37	20x...E053	-	50	40							
20x...F061	-	55	45	20x...E063	-	60	50							
20x...F082	-	75	55	20x...E077	-	75	60							
20x...F098	-	90	75	20x...E099	-	100	75			6	-	6		
20x...F119	-	110	90	20x...E125	-	125	100							
20x...F142	-	132	110	20x...E144	-	150	125							
20x...F171	-	160	132	20x...E192	-	200	150							
20x...F212	-	200	160	20x...E242	-	250	200			7	-	7		
20x...F263	-	250	200	20x...E289	-	300	250							
2xG...F265	315	250	200	20x...E295	350	300	250							
2xG...F330	355	315	250	20x...E355	400	350	300							
2xG...F370	400	355	300	20x...E395	450	400	350							
2xG...F415	450	400	355	20x...E435	500	450	350							
2xG...F460	500	450	375	20x...E460	500	500	400							
2xG...F500	530	500	400	20x...E510	550	500	450							
2xG...F590	630	560	450	20x...E595	700	600	500							
2xG...F650	710	630	500	20x...E630	800	700	600							
2xG...F710	800	710	560	20x...E760	900	800	700							
2xG...F765	850	750	630	20x...E825	950	900	750							
2xG...F795	900	800	710	20x...E900	1000	950	800							
2xG...F960	1000	900	800	20x...E980	1100	1000	900							
2xG...F1K0	1100	1000	900	20x...E1K1	1200	1100	1000							
2xG...F1K4	1500	1400	1120	20x...E1K4	1500	1400	1250							

Enclosure Options

IMPORTANT IP00, IP20, and NEMA/UL Open Type PowerFlex 750-Series drives must be mounted in a clean, dry location. Contaminants such as oils, corrosive vapors, and abrasive debris must be kept out of the enclosure. These enclosures are intended for indoor use primarily to provide a degree of protection against contact with enclosed equipment. These enclosures offer no protection against airborne contaminants. See the following tables for an explanation of enclosure options and the environmental specifications that are found on [page 61](#).

Pollution Degree Ratings According to EN 61800-5-1

Pollution Degree	Description
1	No pollution or only dry, non-conductive pollution occurs. The pollution has no influence.
2	Normally, only non-conductive pollution occurs. Occasionally, a temporary conductivity that is caused by condensation is to be expected, when the drive is out of operation.
3	Conductive pollution or dry non-conductive pollution occurs, which becomes conductive due to condensation, which is to be expected.
4	The pollution generates persistent conductivity that is caused, for example, by conductive dust or rain or snow.

Drive Enclosure Ratings

Frames	Enclosure Type (Cat. No. Position 6)	Installed Accessory Kit	Front Side Rating		Back Side/Heat Sink Rating	
			Enclosure Type	Pollution Degree	Enclosure Type	Pollution Degree
1	R	None	IP20, NEMA/UL Open Type	1, 2	IP20, NEMA/UL Open Type	1, 2
		NEMA Type 1	IP20, NEMA/UL Type 1	1, 2	IP20, NEMA/UL Type 1	1, 2
2...5	N	None	IP20, NEMA/UL Open Type	1, 2	IP20, NEMA/UL Open Type	1, 2
		NEMA Type 1	IP20, NEMA/UL Type 1	1, 2	IP20, NEMA/UL Type 1	1, 2
		Flange	IP20, NEMA/UL Type 1	1, 2	IP20, NEMA/UL Type 1	1, 2
	F	None	IP20, NEMA/UL Open Type	1, 2	IP66, NEMA/UL Type 4X	1, 2, 3, 4
	G	None	IP54, NEMA/UL Type 12	1, 2, 3, 4	IP54, NEMA/UL Type 12	1, 2, 3, 4
6 and 7	N	None	IP00, NEMA/UL Open Type	1, 2	IP00, NEMA/UL Open Type Kit	1, 2
		NEMA Type 1	IP20, NEMA/UL Type 1	1, 2	IP20, NEMA/UL Type 1	1, 2
		NEMA Type 4X flange	IP00, NEMA/UL Open Type	1, 2	IP66, NEMA/UL Type 4X	1, 2, 3, 4
	G	None	IP54, NEMA/UL Type 12	1, 2, 3, 4	IP54, NEMA/UL Type 12	1, 2, 3, 4
8...10	B, L, P, W	None	IP20, NEMA/UL Type 1, MCC	1, 2	IP20, NEMA/UL Type 1	1, 2
	J, K, Y	None	IP54, NEMA 12	1, 2, 3, 4	IP54, NEMA 12	1, 2, 3, 4

Minimum Mounting Clearances

Specified vertical clearance requirements are intended to be from the drive to the closest object that can restrict airflow through the drive heat sink and chassis. The drive must be mounted in a vertical orientation as shown and must make full contact with the mounting surface. Do not use standoffs or spacers. In addition, inlet air temperature must not exceed the product specification.

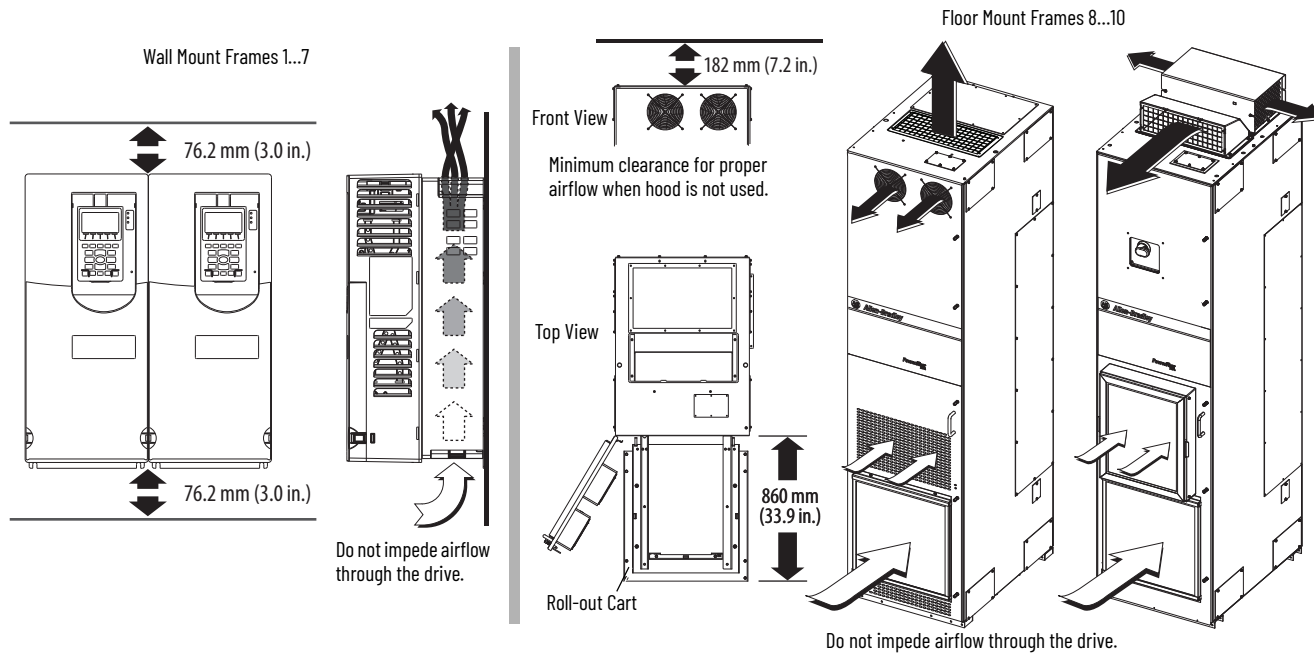

Approximate Weights

Drive	Frame Size	Drive Rating		Enclosure Code/Weight, kg (lb)				
		kW (208V ⁽¹⁾ , 400V, 690V)	Hp (240V ⁽¹⁾ , 480V, 600V)	F	G	N	R	
Standard (20F, 20G)	AC input and common DC input	1	0.37...7.5	0.5...10				7 (15)
		2	0.37...11	0.5...15	9 (20)	10 (22)	8 (18)	
		3	7.5...22	0.5...30	13 (29)	14 (31)	11 (25)	
		4	15...37	20...50	17 (37)	18 (39)	16 (35)	
		5	18.5...55	25...70	24 (54)	26 (57)	24 (52)	
		6	5.5...7.5	7.5...100	37 (82)	89 (197)	37 (82)	
			45...132	50...200	38 (84)	116 (256)	39 (85)	
		7	132...200	150...300	69 (152)	135 (297)	79 (174)	
200...270	300...400		96 (212)	162 (357)	106 (234)			
				B, L	P, W	J	K, Y	
Standard (20G)	AC input	8	250...400	350...650	623 (1374)	1145 (2525)	644 (1419)	1166 (2570)
		9	500...850	700...1250	1246 (2748)	2290 (5051)	1287 (2838)	2332 (5141)
		10	900...1250	1350...1750	1869 (4122)	3435 (7576)	1931 (4257)	3498 (7711)
	Common DC input	8	250...400	350...650	566 (1248)	1088 (2400)	586 (1293)	1109 (2445)
		9	500...850	700...1250	1132 (2497)	2176 (4799)	1173 (2587)	2218 (4889)
		10	900...1250	1350...1750	1698 (3745)	3264 (7199)	1760 (3880)	3327 (7334)
With options (21G)	AC input	8	250...400	350...650	1145 (2525)	1675 (3694)	1166 (2570)	1696 (3739)
		9	500...850	700...1250	1730 (3815)	2820 (6219)	1771 (3905)	2862 (6309)
		10	900...1250	1350...1750	2315 (5106)	3965 (8745)	2377 (5241)	4028 (8880)

(1) Only Frame 1...7 available for 208V, 240V input drives.

Maximum Component Weights - Frames 8...10

Component	AC Input, kg (lb)	Common DC Input, kg (lb)
Converter/DC input with precharge	64 (140)	64 (140)
Inverter	222 (490)	165 (363)
Drive assembly (Open, IP00)	329 (725)	229 (504)

Approximate Dimensions

This section provides the approximate dimensions for the drives.

Dimension Drawing Index

Frame	Description	Page
1	IP20, NEMA/UL Type Open	136
2	IP20, NEMA/UL Type Open	136
	Flange Mount	137
	IP54, NEMA/UL Type 12	138
3	IP20, NEMA/UL Open Type	138
	Flange Mount	139
	IP54, NEMA/UL Type 12	140
4	IP20, NEMA/UL Open Type	140
	Flange Mount	141
	IP54, NEMA/UL Type 12	142
5	IP20, NEMA/UL Open Type	142
	Flange Mount	143
	IP54, NEMA/UL Type 12	144
6	IP00, NEMA/UL Open Type	145
	Flange Mount	146
	IP54, NEMA/UL Type 12	147
7	IP00, NEMA/UL Open Type	148
	Flange Mount	149
	NEMA/UL Type 1	150
	IP54, NEMA/UL Type 12	151
8	MCC Style Cabinet, 600 mm (23.6 in.) Deep - IP20	152
	MCC Style Cabinet with Wiring Bay, 600 mm (23.6 in.) Deep - IP20	153
	MCC Style Cabinet with Cabinet Option Bay, 600 mm (23.6 in.) Deep - IP20	154
	MCC Style Cabinet with Wiring Bay and Cabinet Option Bay, 600 mm (23.6 in.) Deep - IP20	155
	MCC Style Cabinet, 800 mm (31.5 in.) Deep - IP20	156
	MCC Style Cabinet with Wiring Bay, 800 mm (31.5 in.) Deep - IP20	157
	MCC Style Cabinet with Cabinet Option Bay, 800 mm (31.5 in.) Deep - IP20	158
	MCC Style Cabinet with Wiring Bay and Cabinet Option Bay, 800 mm (31.5 in.) Deep - IP20	159
	MCC Style Cabinet, 800 mm (31.5 in.) Deep - IP54	160
	MCC Style Cabinet with Wiring Bay, 800 mm (31.5 in.) Deep - IP54	161
	MCC Style Cabinet with Cabinet Option Bay, 800 mm (31.5 in.) Deep - IP54	162
	MCC Style Cabinet with Wiring Bay and Cabinet Option Bay, 800 mm (31.5 in.) Deep - IP54	163
	Open Style - AC Input	164
	Open Style - DC Input	165

Dimension Drawing Index (Continued)

Frame	Description	Page
9	MCC Style Cabinet, 600 mm (23.6 in.) Deep - IP20	166
	MCC Style Cabinet with Wiring Bay, 600 mm (23.6 in.) Deep - IP20	167
	MCC Style Cabinet with Cabinet Option Bay, 600 mm (23.6 in.) Deep - IP20	168
	MCC Style Cabinet with Cabinet Option Bay and Wiring Bay, 600 mm (23.6 in.) Deep - IP20	169
	MCC Style Cabinet, 800 mm (31.5 in.) Deep - IP20	170
	MCC Style Cabinet with Wiring Bay, 800 mm (31.5 in.) Deep - IP20	171
	MCC Style Cabinet with Cabinet Option Bay, 800 mm (31.5 in.) Deep - IP20	172
	MCC Style Cabinet with Cabinet Option Bay and Wiring Bay, 800 mm (31.5 in.) Deep - IP20	173
	MCC Style Cabinet, 800 mm (31.5 in.) Deep - IP54	174
	MCC Style Cabinet with Wiring Bay, 800 mm (31.5 in.) Deep - IP54	175
	MCC Style Cabinet with Cabinet Option Bay, 800 mm (31.5 in.) Deep - IP54	176
	MCC Style Cabinet with Cabinet Option Bay and Wiring Bay, 800 mm (31.5 in.) Deep - IP54	177
	Open Style - AC Input	178
	Open Style - DC Input	179
10	MCC Style Cabinet, 600 mm (23.6 in.) Deep - IP20	180
	MCC Style Cabinet, 800 mm (31.5 in.) Deep - IP20	181
	MCC Style Cabinet 800 mm (31.5 in.) Deep - IP54	182
	Open Style - AC Input	183
	Open Style - DC Input	184
1...6	NEMA/UL Type 1 Kit	185
1...5	NEMA/UL Type 1 Bottom View	186
1...5	EMC Plate and Cores Kit	187

Frame	Type	Approximate Dimensions - mm (in.)																						
1, 2	IP20, NEMA/UL Type Open																							
		<table border="1"> <thead> <tr> <th>Frame</th> <th>A</th> <th>B</th> <th>C</th> <th>D</th> <th>E</th> <th>F</th> <th>Weight kg (lb)</th> </tr> </thead> <tbody> <tr> <td>1</td> <td>110.0 (4.33)</td> <td>400.5 (15.77)</td> <td>211.0 (8.31)</td> <td>68.0 (2.68)</td> <td>82.0 (3.23)</td> <td>390.4 (15.37)</td> <td>6.0 (12.75)</td> </tr> <tr> <td>2</td> <td>134.5 (5.30)</td> <td>424.2 (16.70)</td> <td>212.0 (8.35)</td> <td>100.0 (3.94)</td> <td>100.0 (3.94)</td> <td>404.2 (15.91)</td> <td>7.8 (17.2)</td> </tr> </tbody> </table>	Frame	A	B	C	D	E	F	Weight kg (lb)	1	110.0 (4.33)	400.5 (15.77)	211.0 (8.31)	68.0 (2.68)	82.0 (3.23)	390.4 (15.37)	6.0 (12.75)	2	134.5 (5.30)	424.2 (16.70)	212.0 (8.35)	100.0 (3.94)	100.0 (3.94)
Frame	A	B	C	D	E	F	Weight kg (lb)																	
1	110.0 (4.33)	400.5 (15.77)	211.0 (8.31)	68.0 (2.68)	82.0 (3.23)	390.4 (15.37)	6.0 (12.75)																	
2	134.5 (5.30)	424.2 (16.70)	212.0 (8.35)	100.0 (3.94)	100.0 (3.94)	404.2 (15.91)	7.8 (17.2)																	

Frame Type Approximate Dimensions - mm (in.)

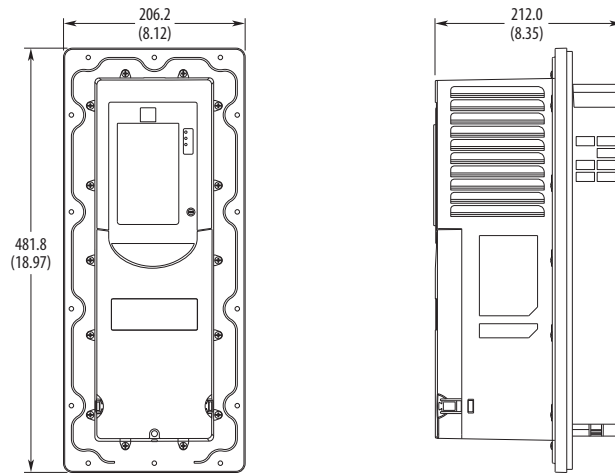

2 Flange Mount

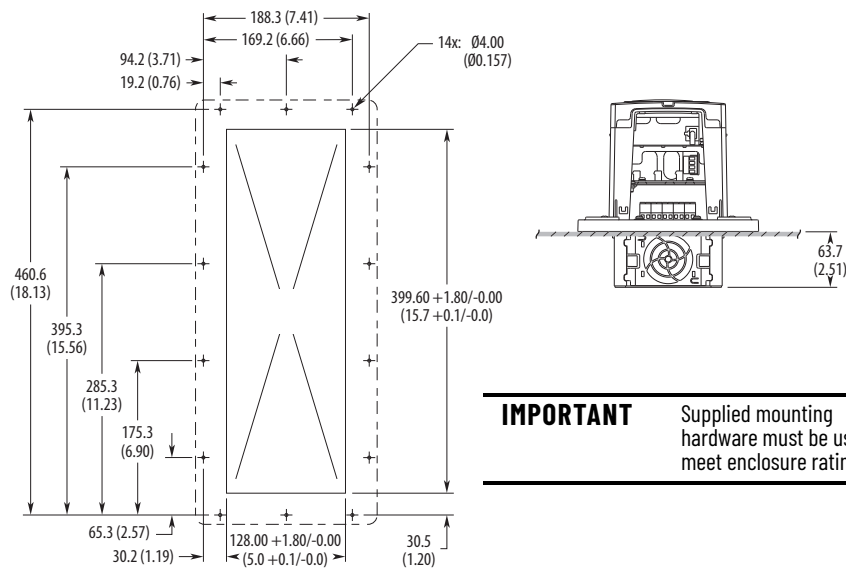

IMPORTANT Supplied mounting hardware must be used to meet enclosure rating.

Frame Type Approximate Dimensions - mm (in.)

2 IP54,
NEMA/UL Type
12

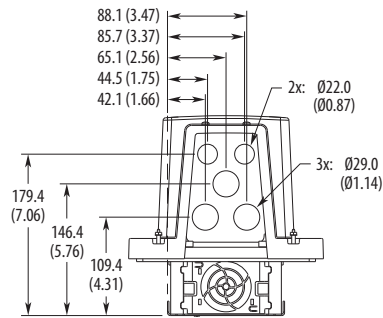
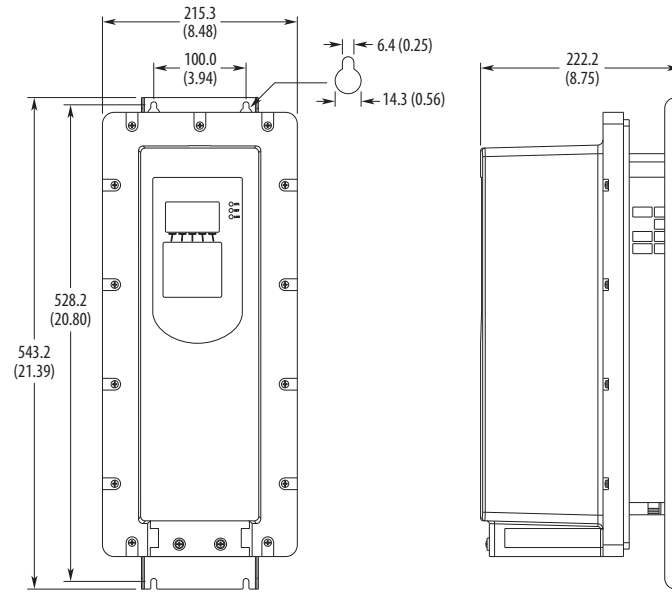

3 IP20,
NEMA/UL Open
Type

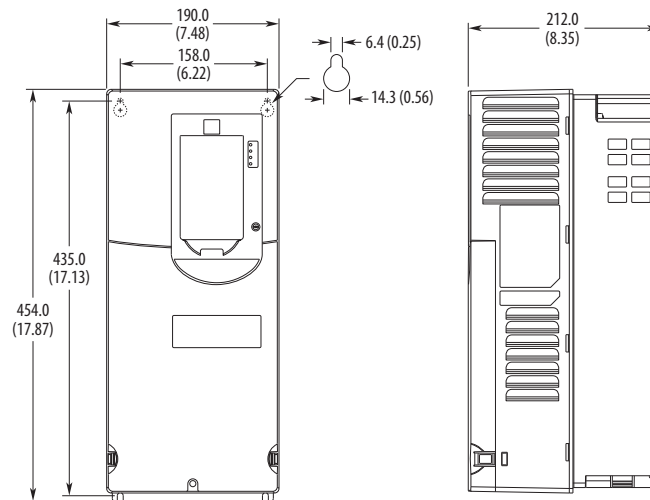

Frame Type Approximate Dimensions - mm (in.)

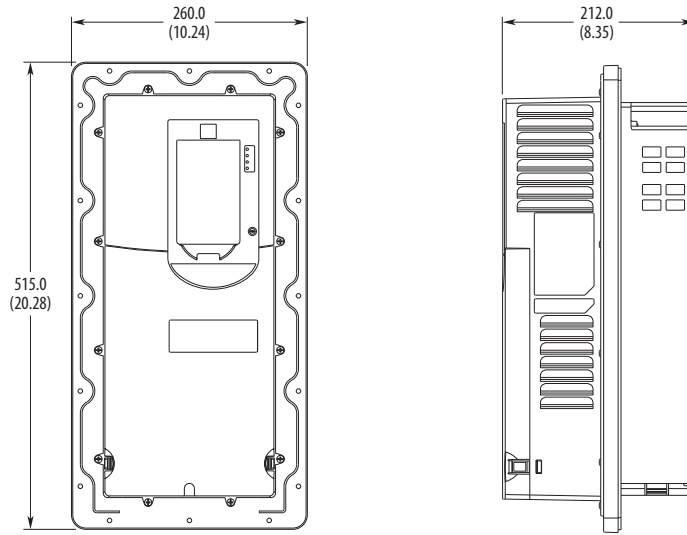

3 Flange Mount

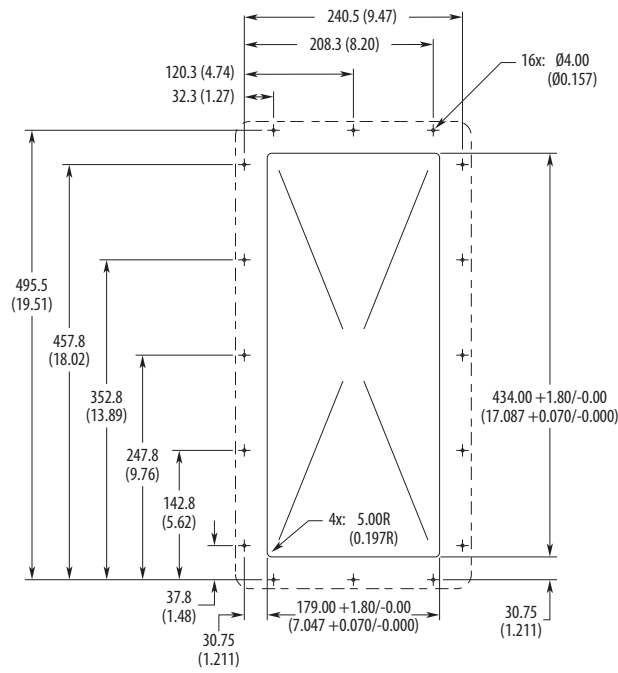

IMPORTANT

Supplied mounting hardware must be used to meet enclosure rating.

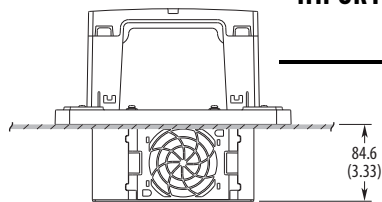

Frame Type Approximate Dimensions - mm (in.)

3 IP54,
NEMA/UL Type
12

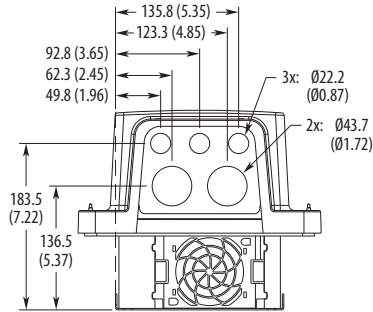
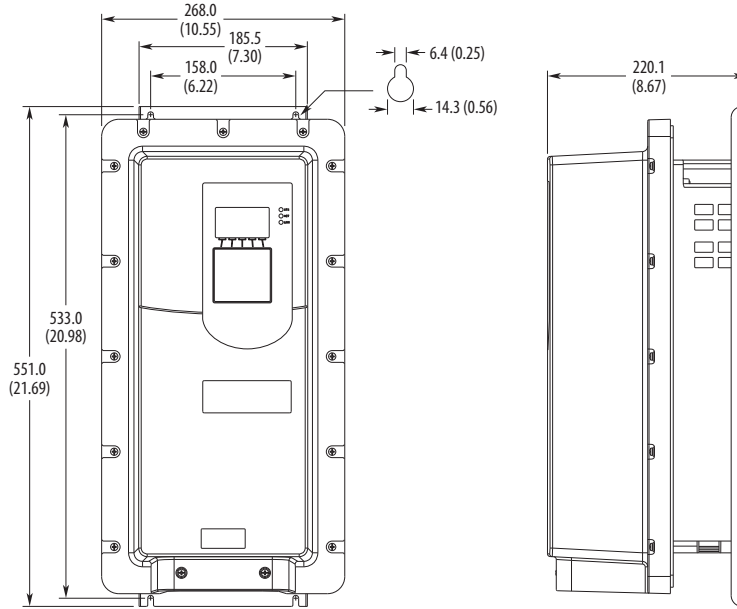

4 IP20,
NEMA/UL Open
Type

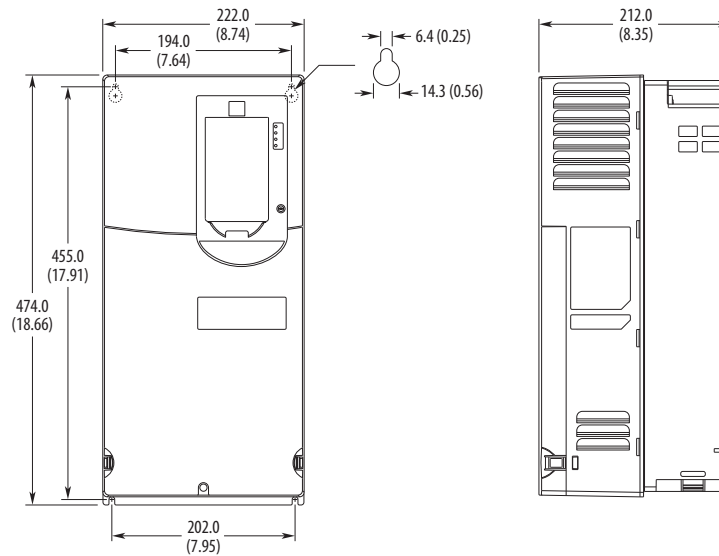

Frame Type Approximate Dimensions - mm (in.)

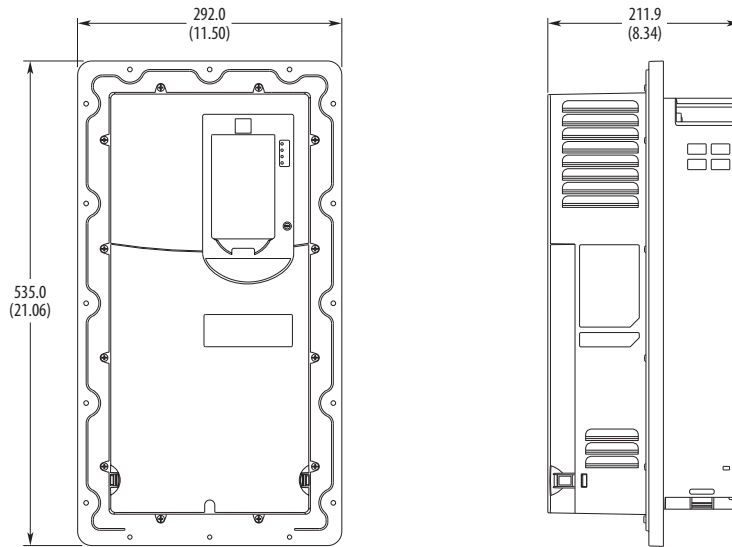

4 Flange Mount

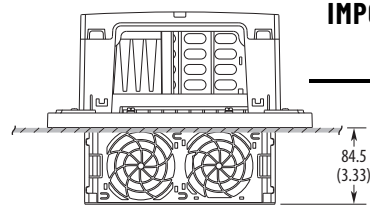
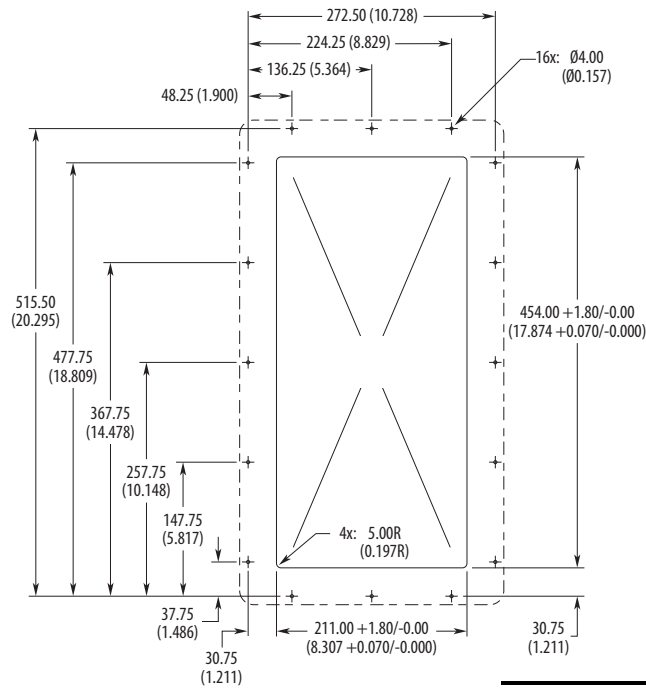

IMPORTANT

Supplied mounting hardware must be used to meet enclosure rating.

Frame Type Approximate Dimensions - mm (in.)

4 IP54,
NEMA/UL Type
12

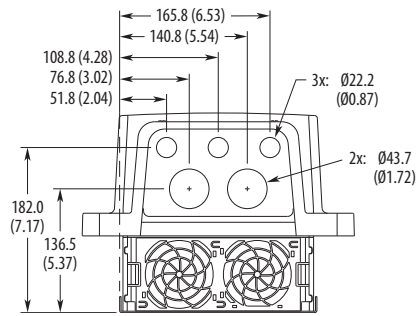
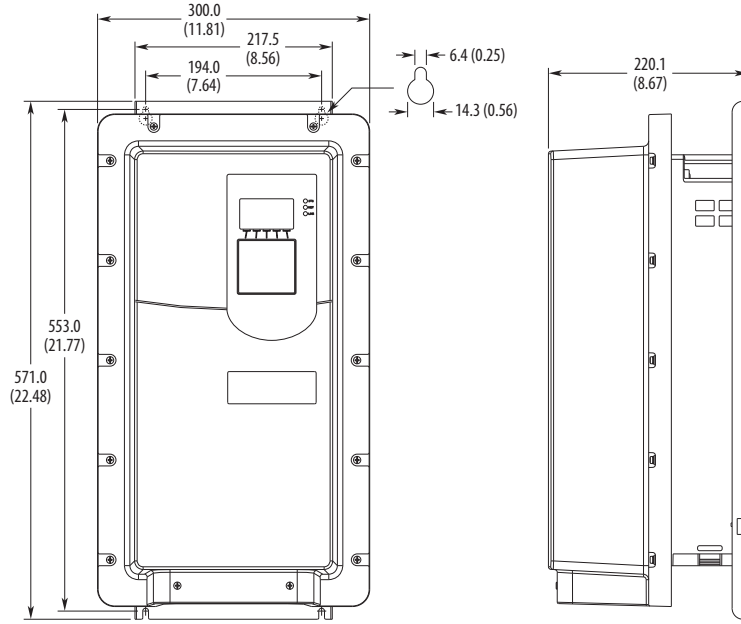

5 IP20,
NEMA/UL Open
Type

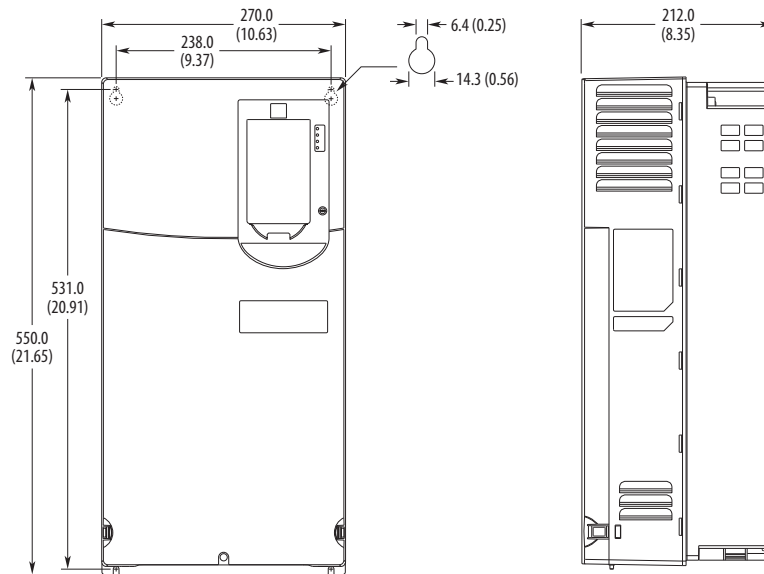

Frame Type **Approximate Dimensions - mm (in.)**

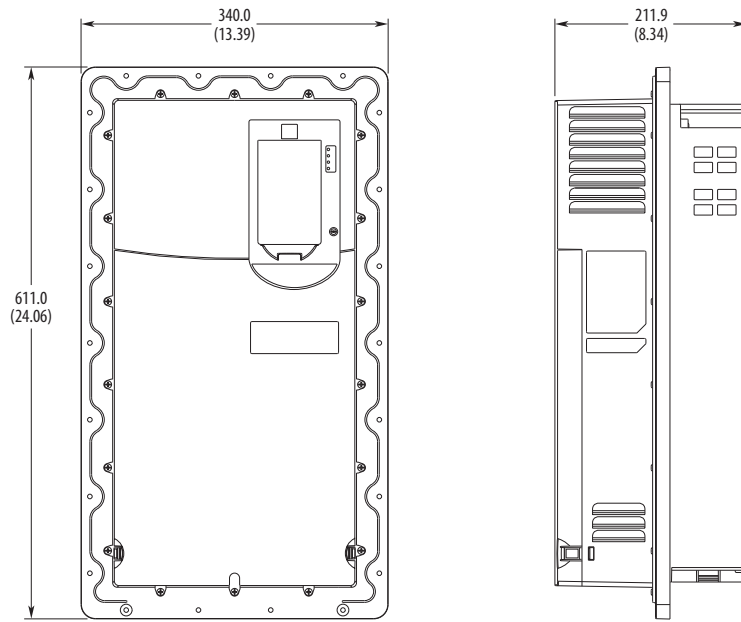

5 **Flange Mount**

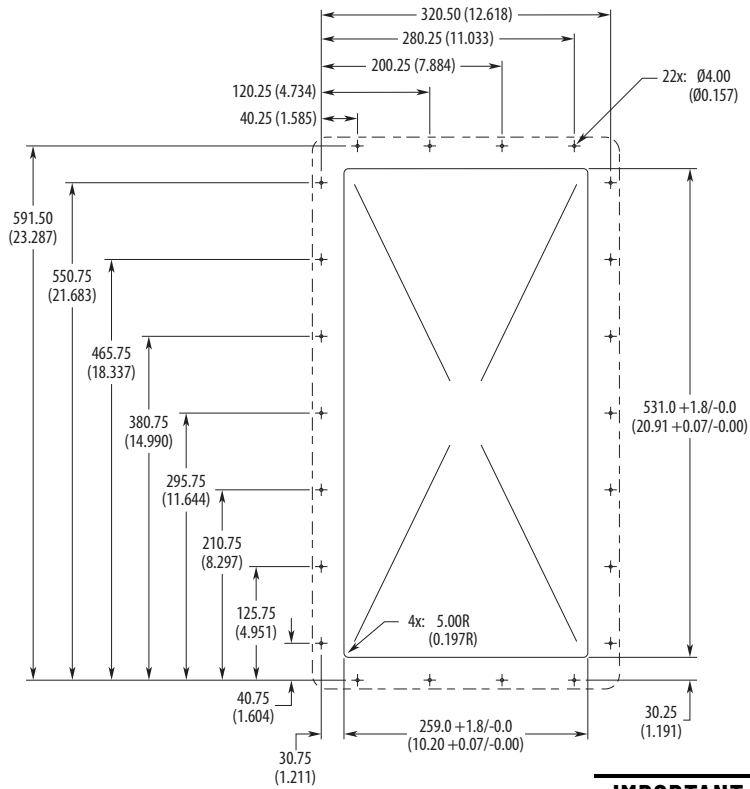

IMPORTANT Supplied mounting hardware must be used to meet enclosure rating.

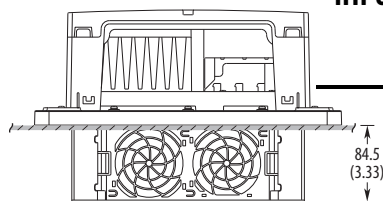

Frame Type **Approximate Dimensions - mm (in.)**

5 IP54,
NEMA/UL Type
12

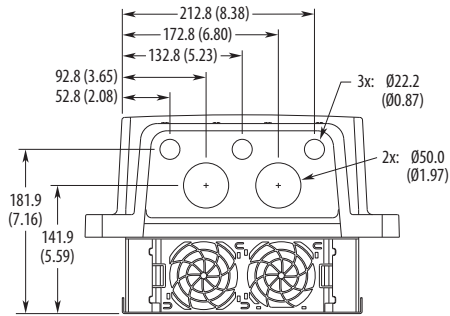
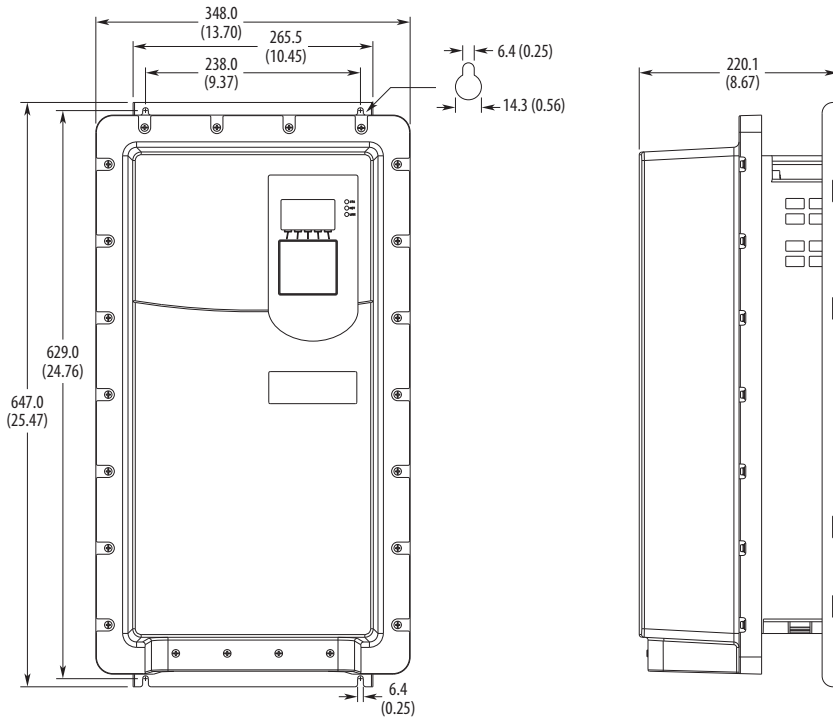

Frame Type Approximate Dimensions - mm (in.)

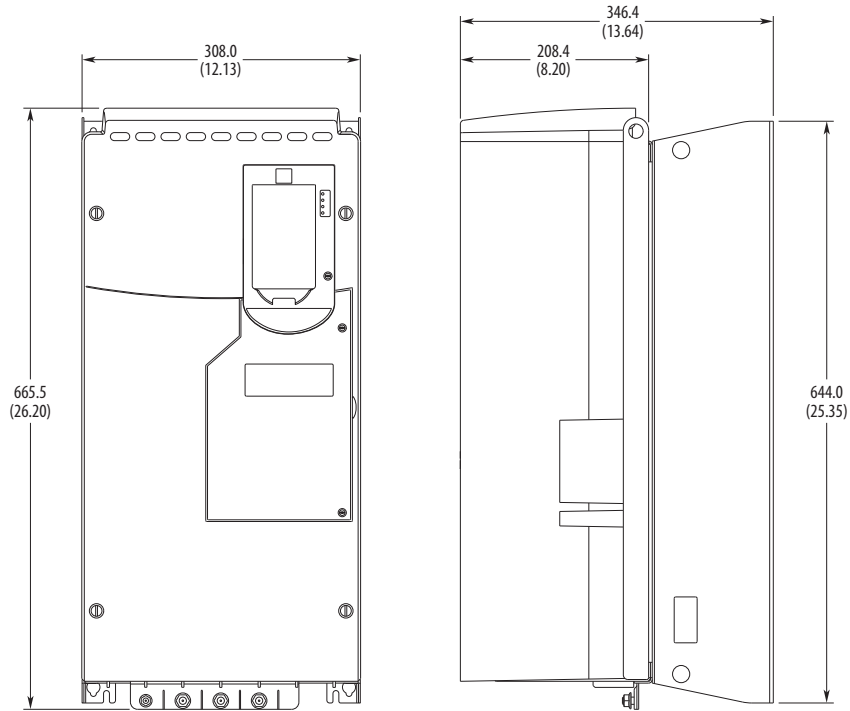

6 IPOD,
NEMA/UL Open
Type

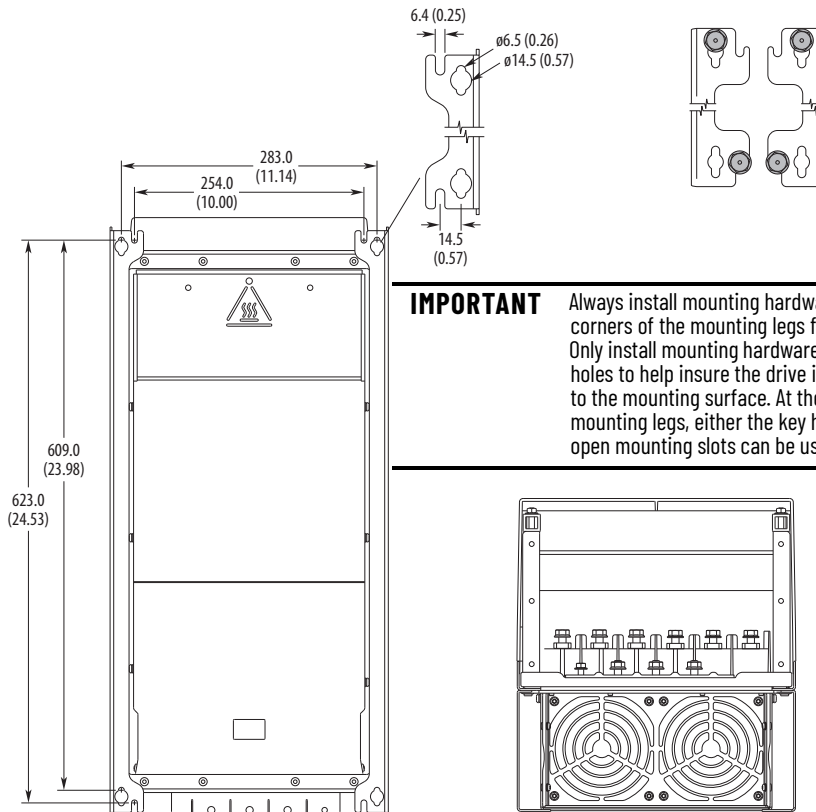

Frame Type Approximate Dimensions - mm (in.)

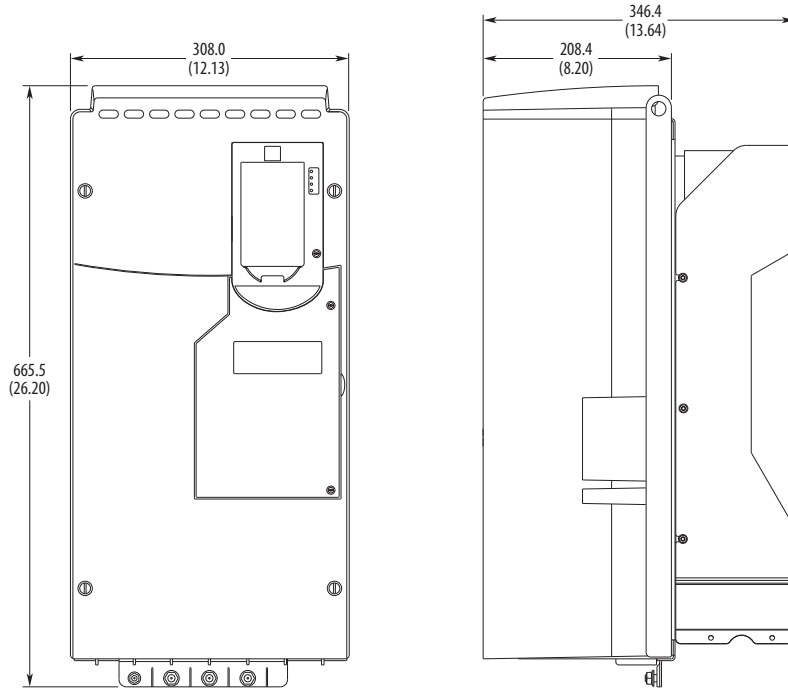

6 Flange Mount

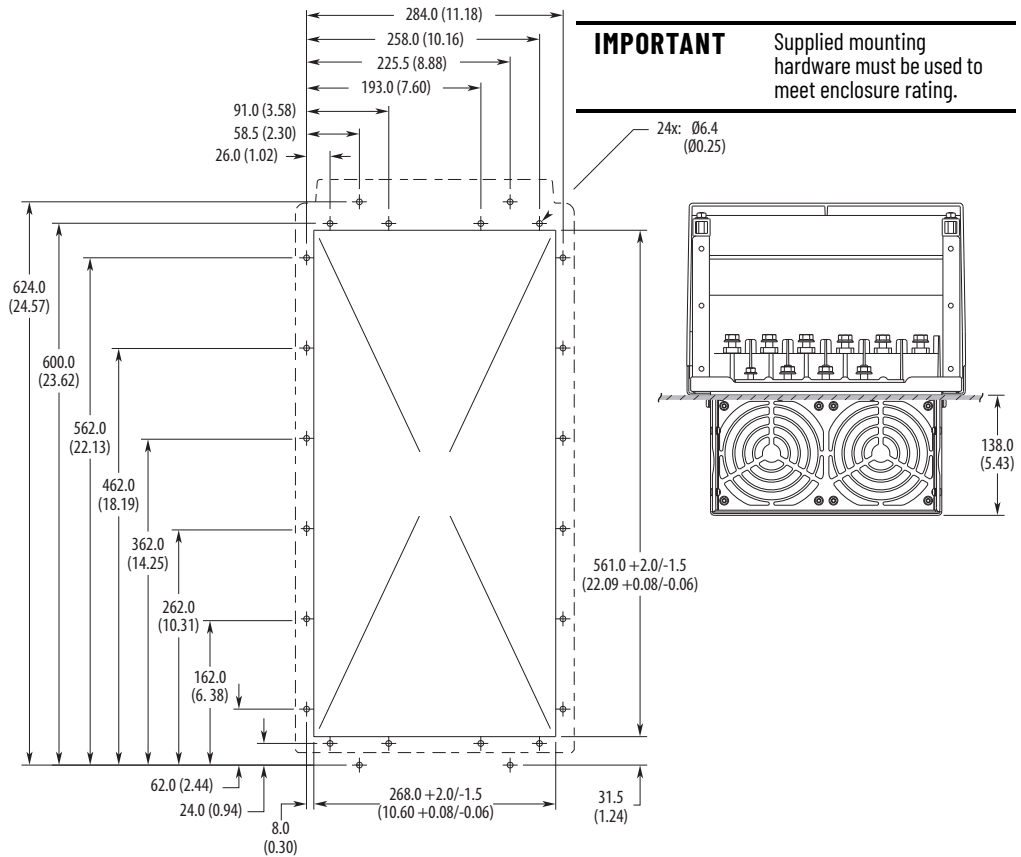

Frame Type Approximate Dimensions - mm (in.)

6 IP54,
NEMA/UL Type
12

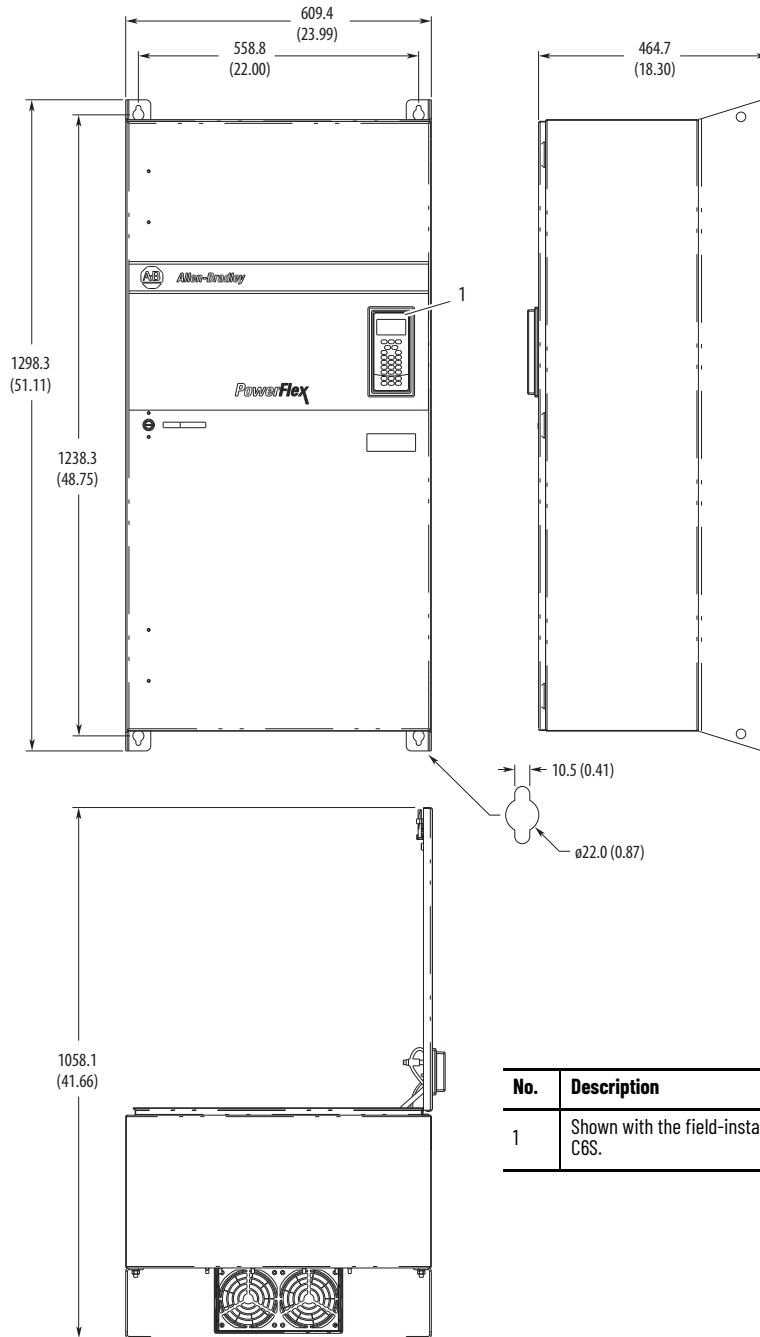

No.	Description
1	Shown with the field-installed 20-HIM-C6S.

Frame Type **Approximate Dimensions - mm (in.)**

7 IPOO,
NEMA/UL Open
Type

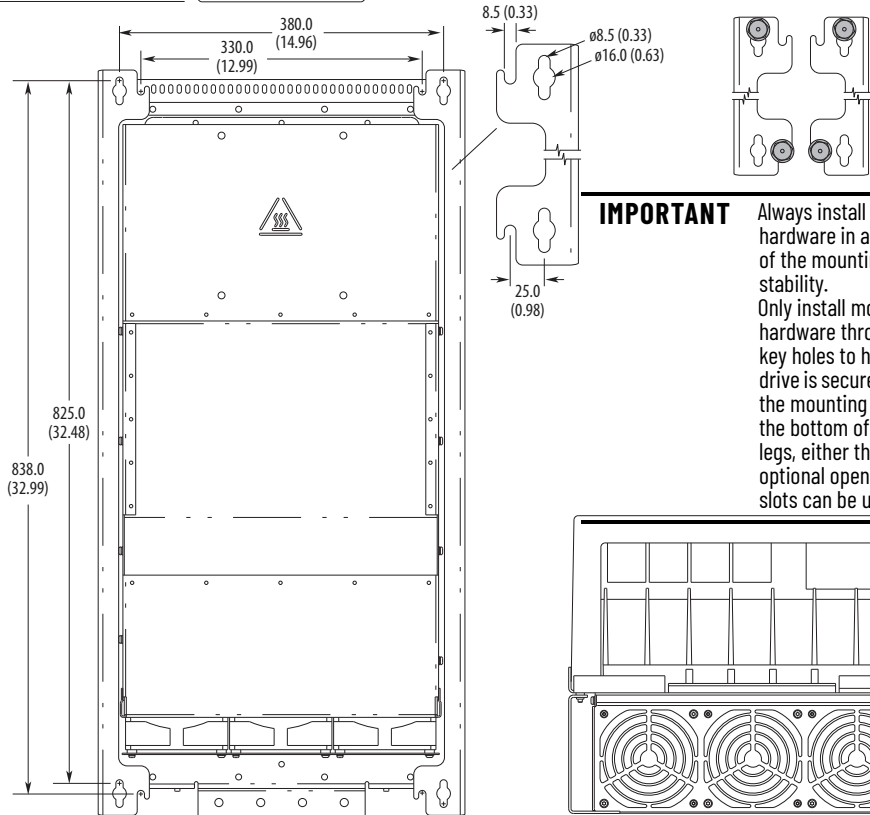
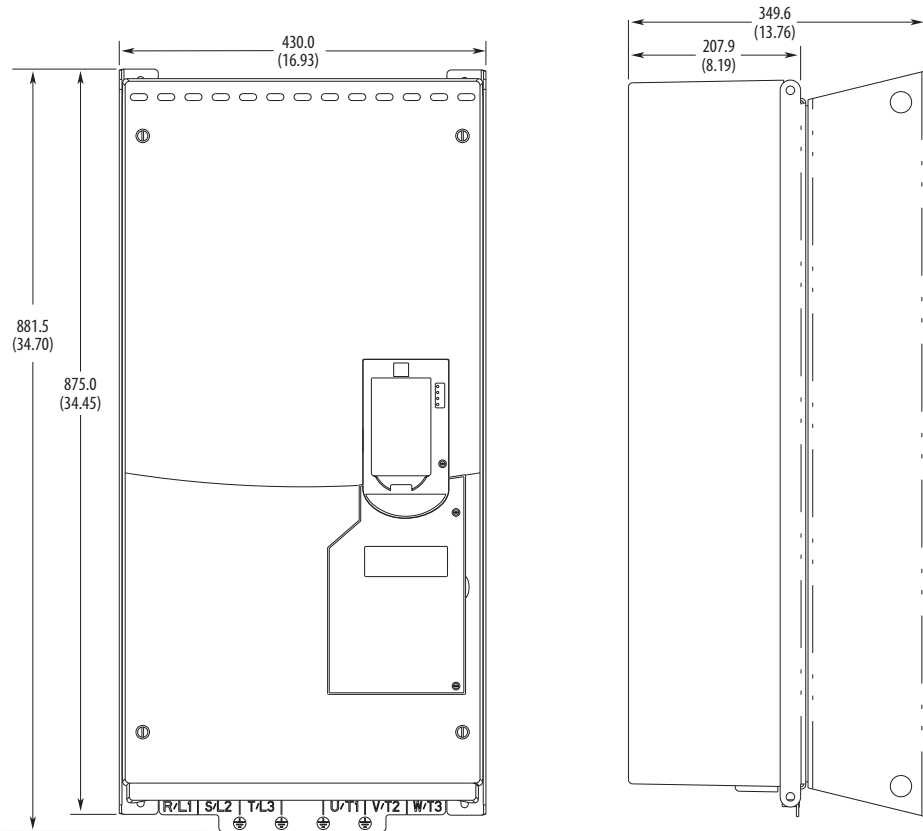

IMPORTANT Always install mounting hardware in all four corners of the mounting legs for stability. Only install mounting hardware through the top key holes to help insure the drive is securely fastened to the mounting surface. At the bottom of the mounting legs, either the key holes or optional open mounting slots can be used.

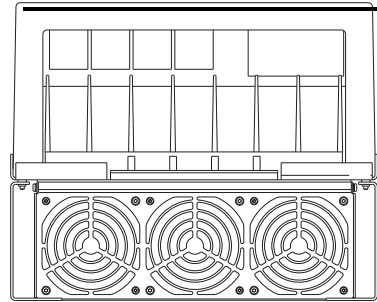

Frame Type **Approximate Dimensions - mm (in.)**

7 **Flange Mount**

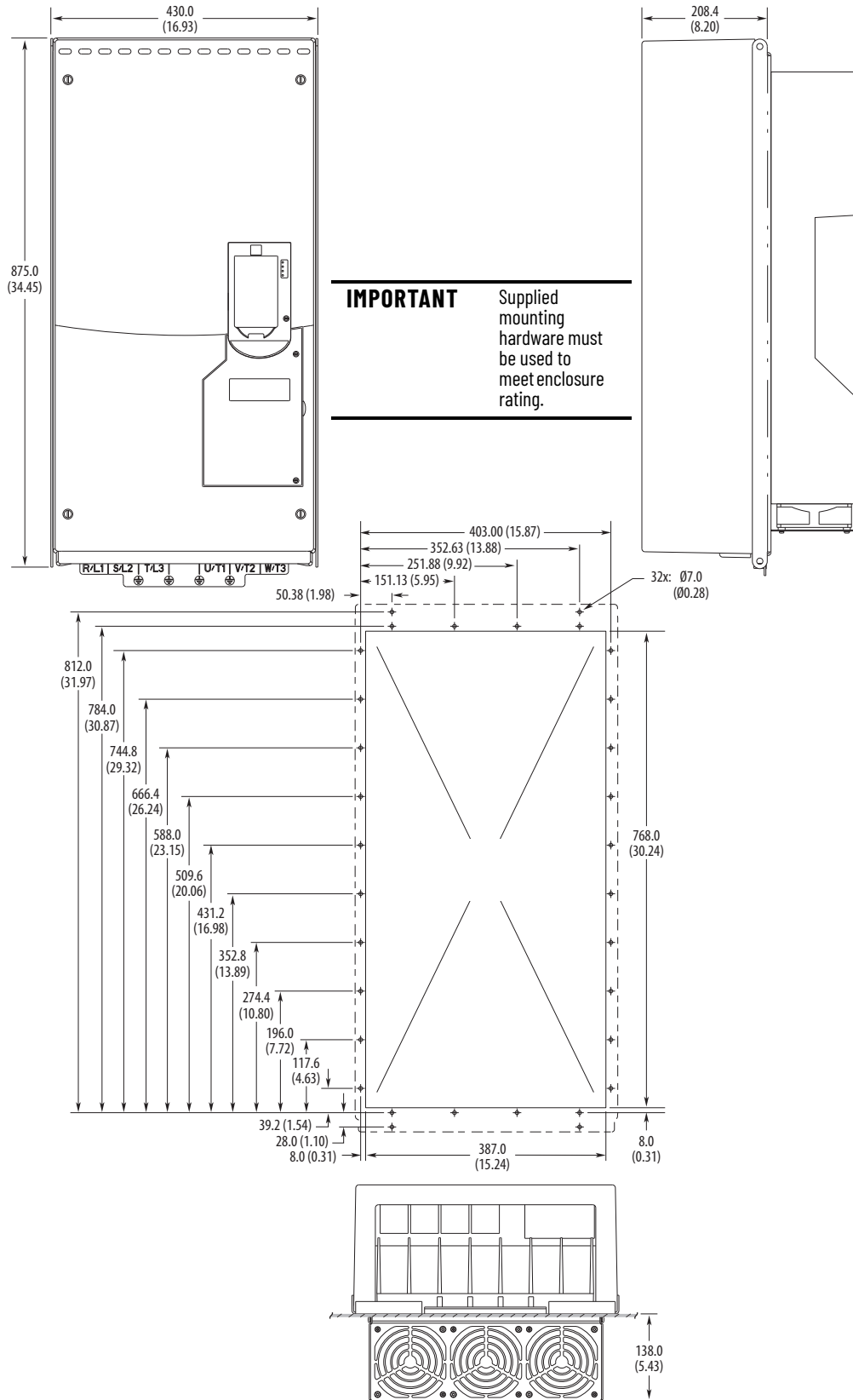

Frame Type **Approximate Dimensions - mm (in.)**

7 NEMA/UL Type 1

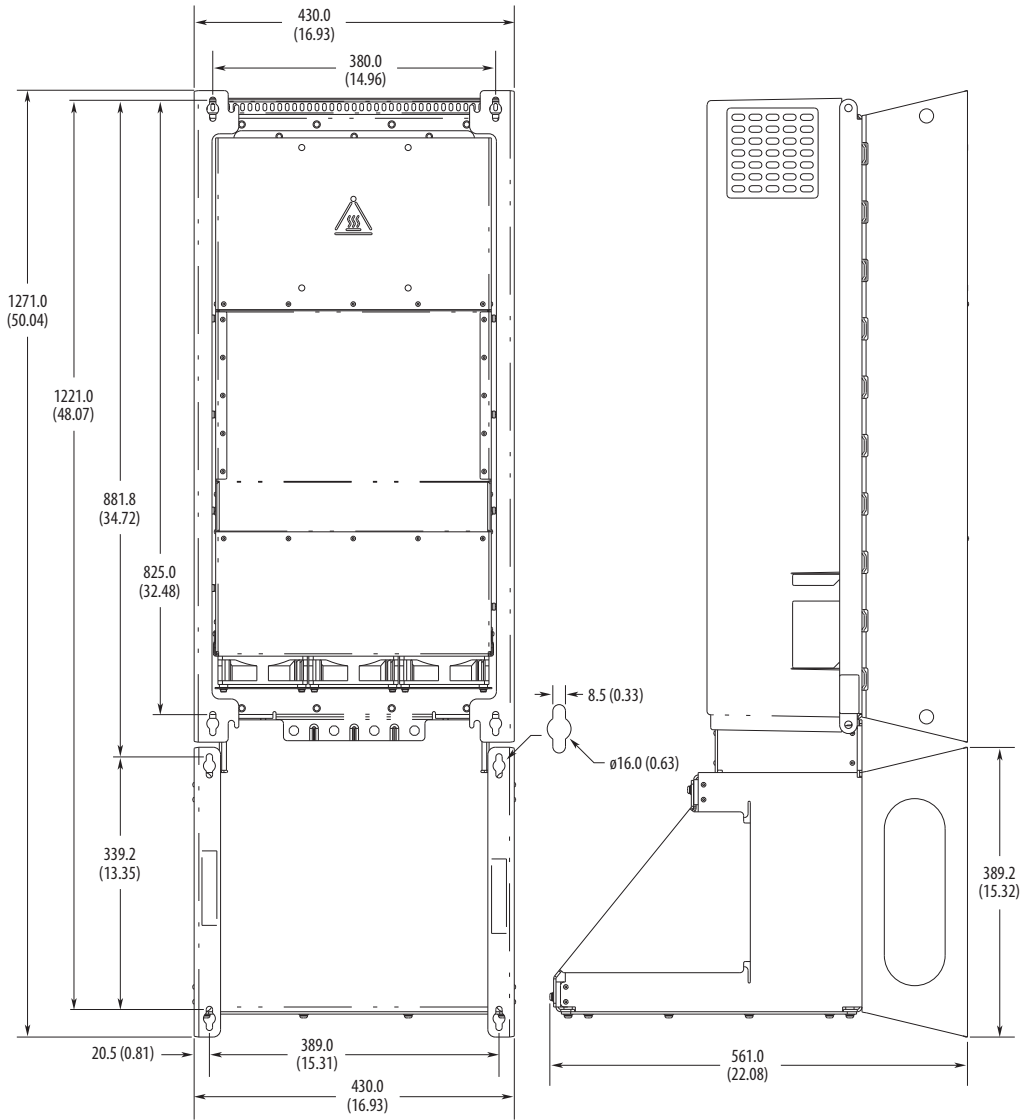

Frame Type Approximate Dimensions - mm (in.)

7 IP54, NEMA/UL
Type 12

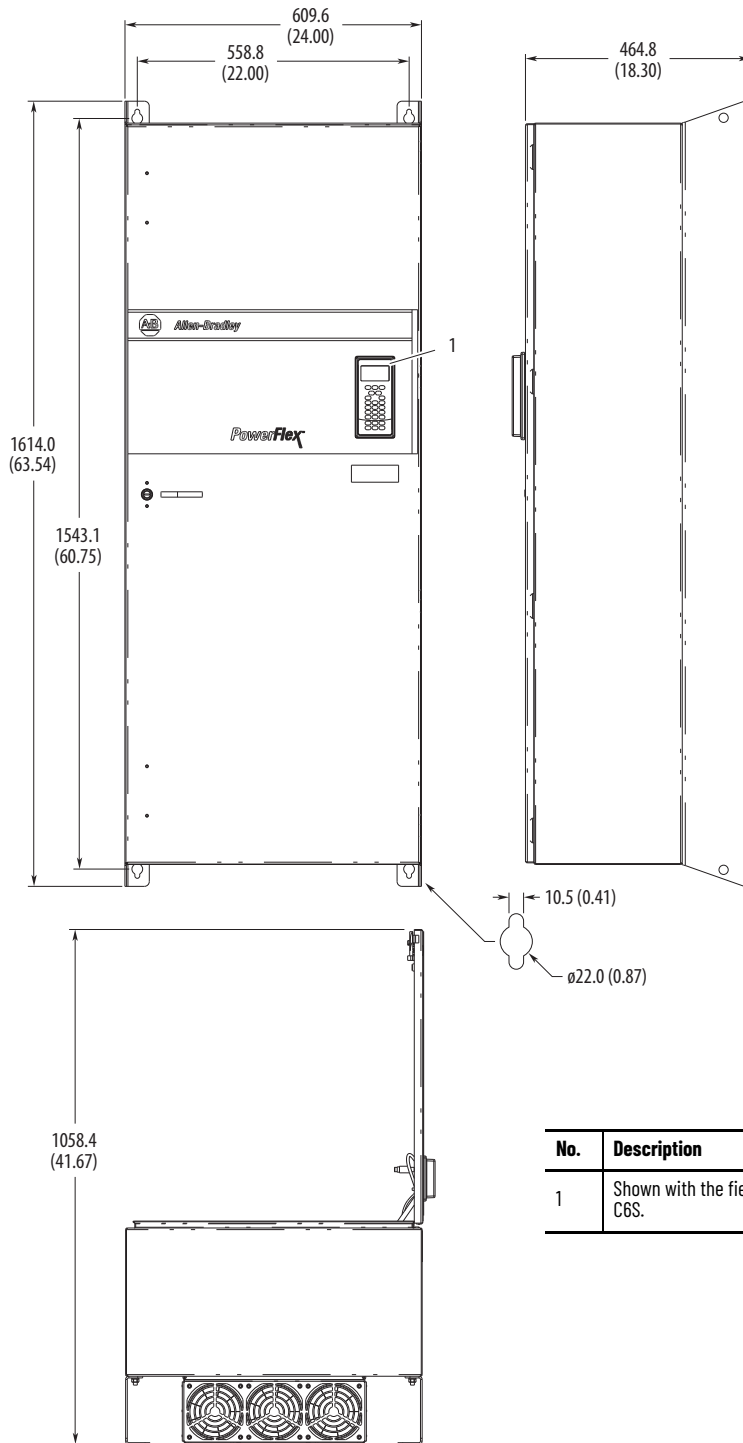

No.	Description
1	Shown with the field-installed 20-HIM-CBS.

Frame Type Approximate Dimensions - mm (in.)

8

MCC Style Cabinet,
600 mm (23.6 in.) Deep
IP20, NEMA/UL Type 1
Enclosure Code B

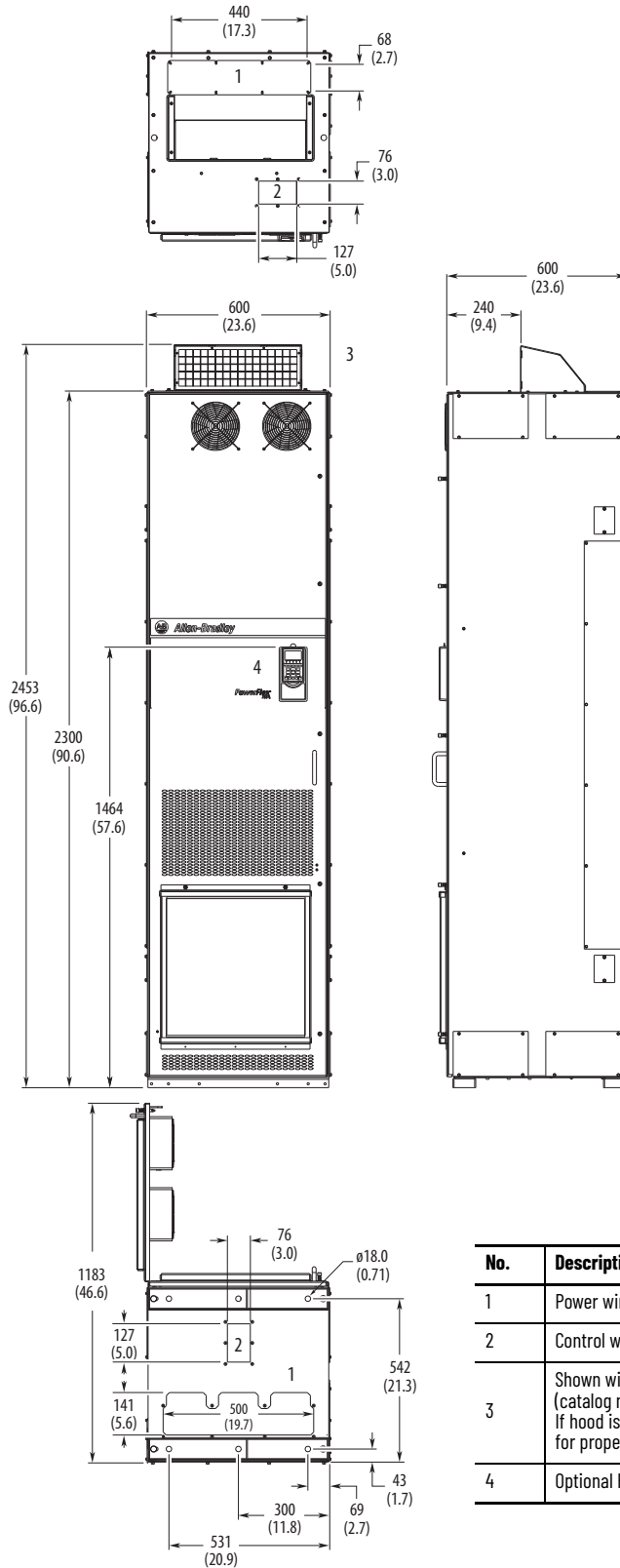

No.	Description
1	Power wiring conduit plates.
2	Control wiring conduit plates.
3	Shown with optional hood (catalog number 20-750-HOOD1-F8). If hood is not used, allow sufficient top clearance for proper airflow. See page 133 .
4	Optional HIM.

Frame Type **Approximate Dimensions - mm (in.)**

8

MCC Style Cabinet with Wiring Bay, 600 mm (23.6 in.) Deep IP20, NEMA/UL Type 1 Enclosure Code B

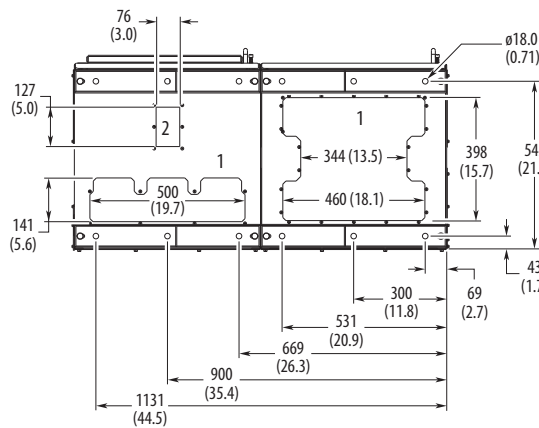
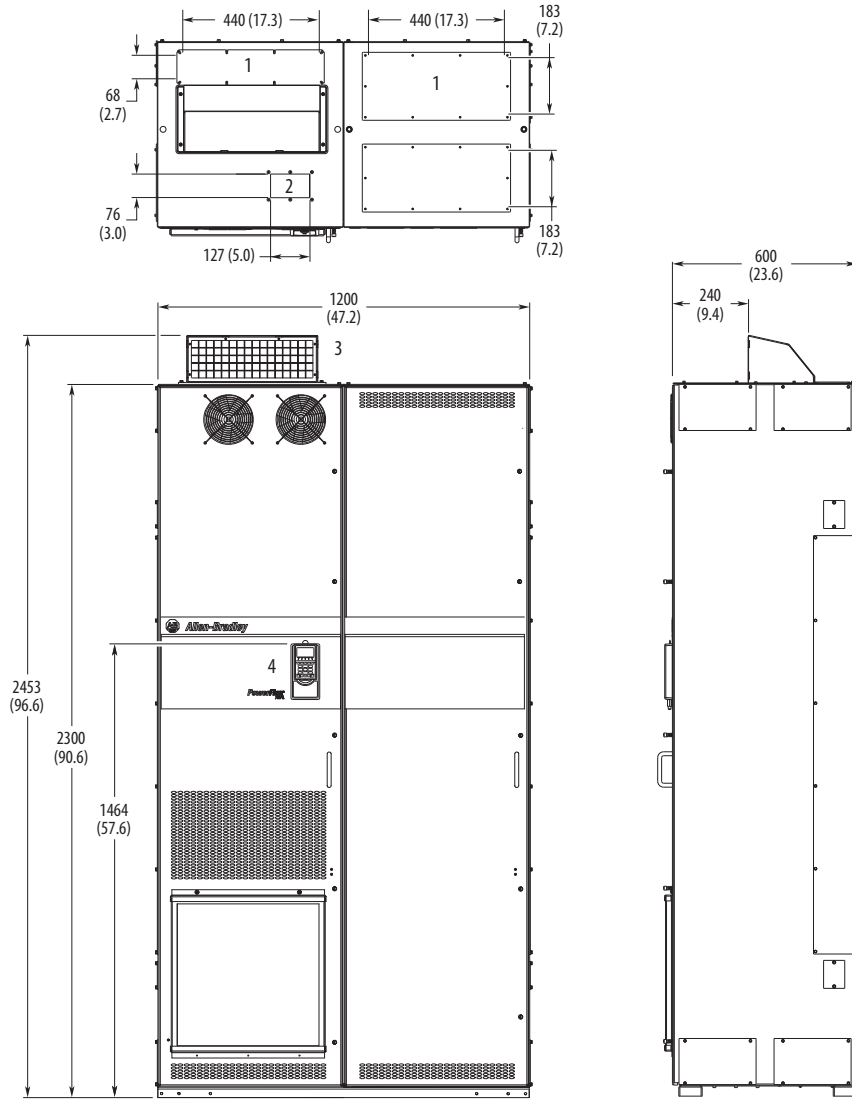

No.	Description
1	Power wiring conduit plates.
2	Control wiring conduit plates.
3	Shown with optional hood (catalog number 20-750-HOOD1-F8). If hood is not used, allow sufficient top clearance for proper airflow. See page 133 .
4	Optional HIM.

Frame Type **Approximate Dimensions - mm (in.)**

8

MCC Style Cabinet with Cabinet Option Bay, 600 mm (23.6 in.) Deep IP20, NEMA/UL Type 1 Enclosure Code B

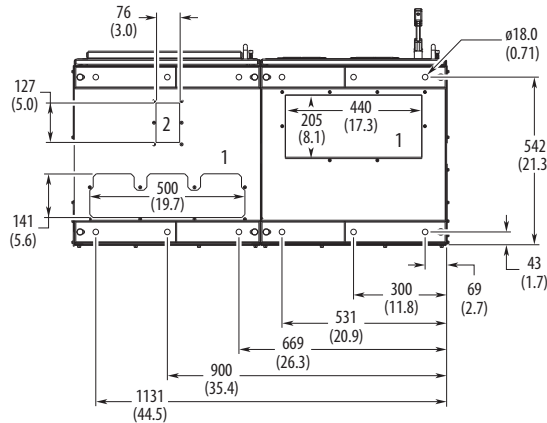
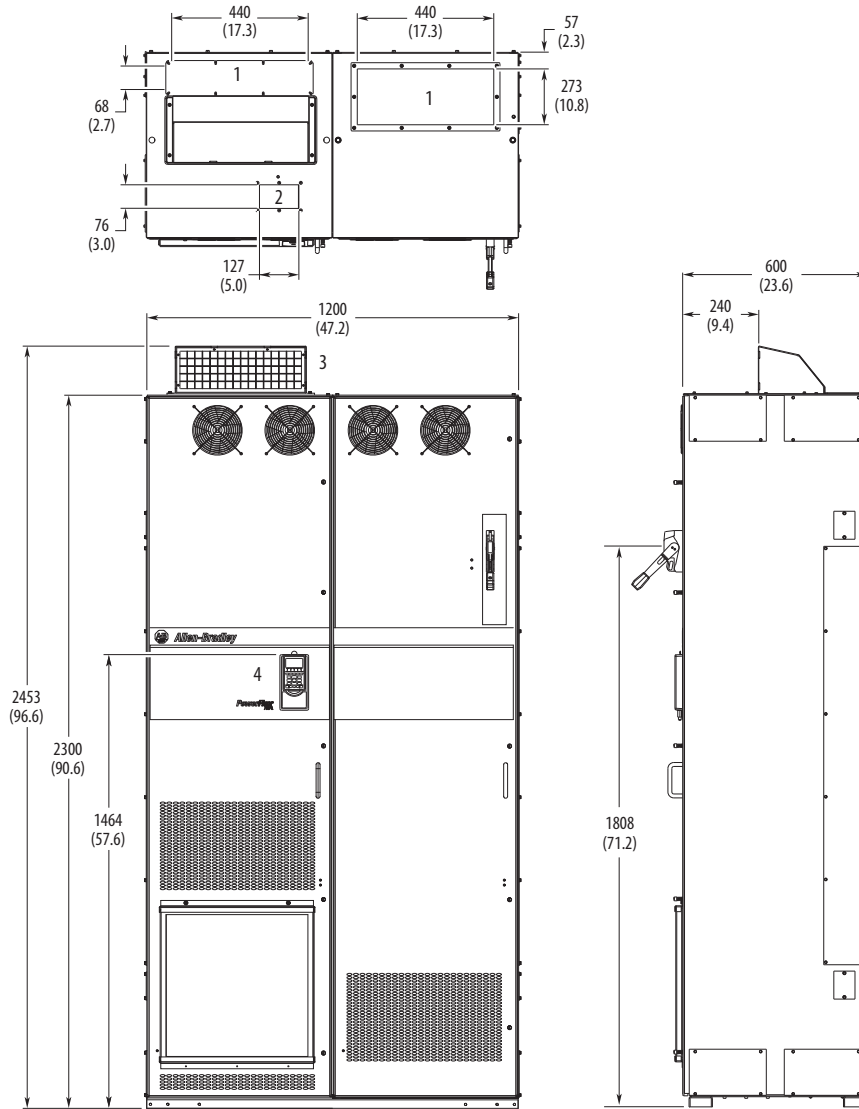

No.	Description
1	Power wiring conduit plates.
2	Control wiring conduit plates.
3	Shown with optional hood (catalog number 20-750-HOOD1-F8). If hood is not used, allow sufficient top clearance for proper airflow. See page 133 .
4	Optional HIM.

Frame Type **Approximate Dimensions - mm (in.)**

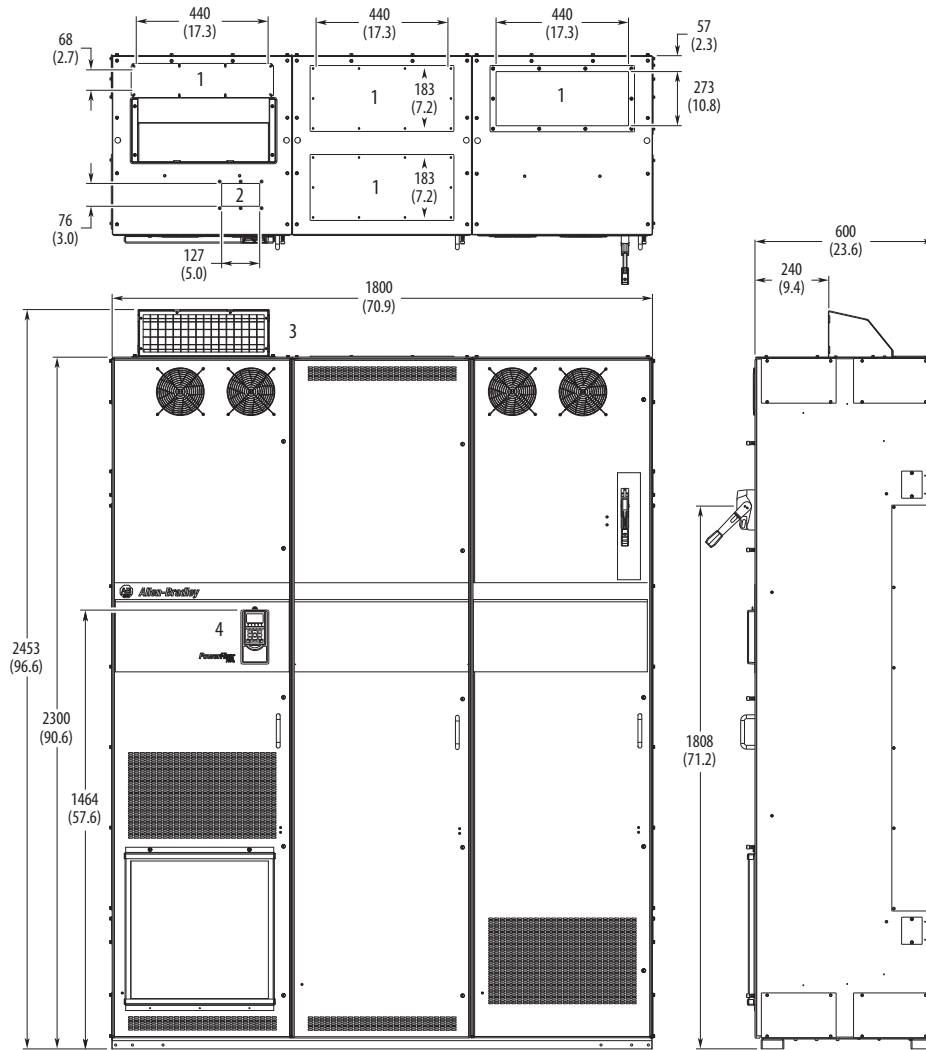

MCC Style Cabinet with Wiring Bay and Cabinet Option Bay, 600 mm (23.6 in.) Deep IP20, NEMA/UL Type 1 Enclosure Code B

8

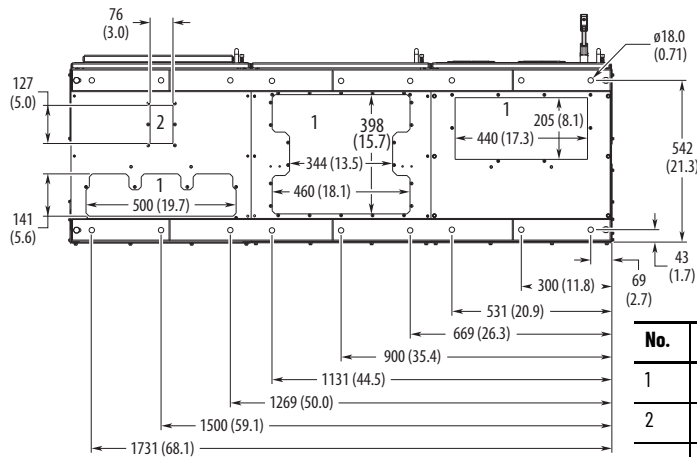

No.	Description
1	Power wiring conduit plates.
2	Control wiring conduit plates.
3	Shown with optional hood (catalog number 20-750-H0001-F8). If hood is not used, allow sufficient top clearance for proper airflow. See page 133 .
4	Optional HIM.

Frame Type **Approximate Dimensions - mm (in.)**

8

MCC Style Cabinet, 800 mm (31.5 in.) Deep
 IP20, NEMA/UL Type 1
 Enclosure Code L (AC Input)
 Enclosure Codes P, W (DC Input)

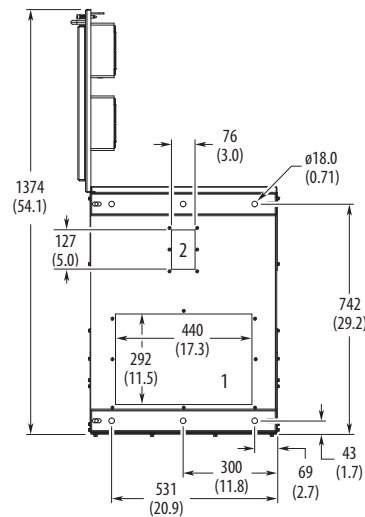
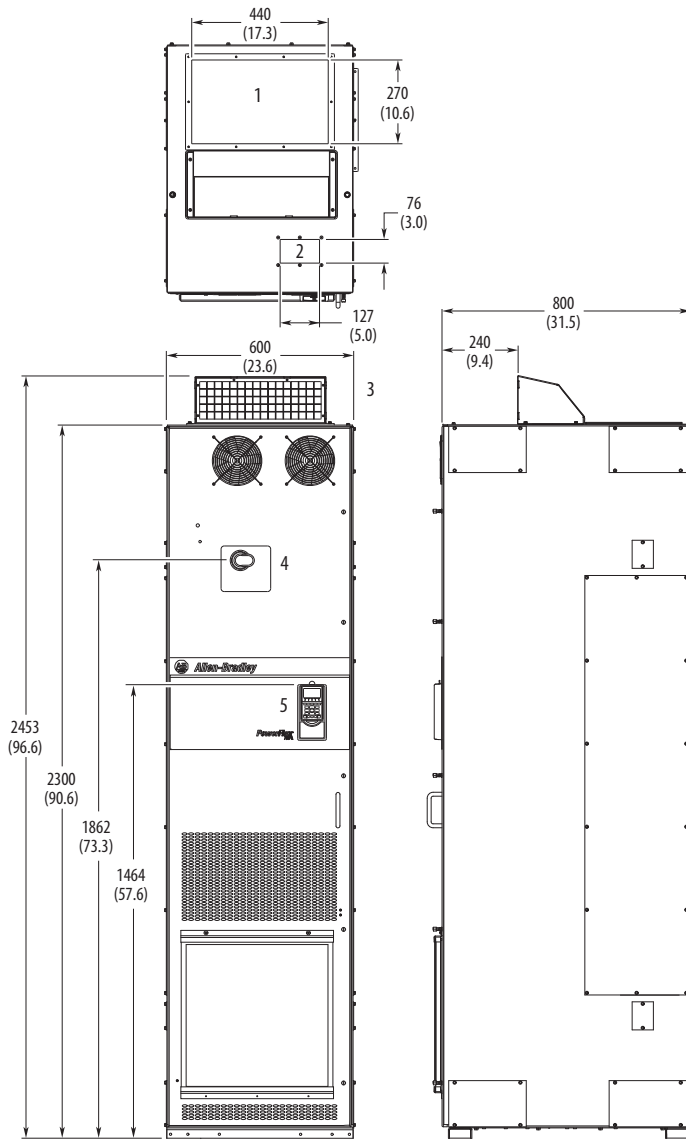

No.	Description
1	Power wiring conduit plates.
2	Control wiring conduit plates.
3	Shown with optional hood (catalog number 20-750-HOOD1-F8). If hood is not used, allow sufficient top clearance for proper airflow. See page 133 .
4	Disconnect switch - Common DC Input drives.
5	Optional HIM.

Frame Type **Approximate Dimensions - mm (in.)**

8

MCC Style Cabinet with Wiring Bay, 800 mm (31.5 in.) Deep IP20, NEMA/UL Type 1 Enclosure Code L, P, W

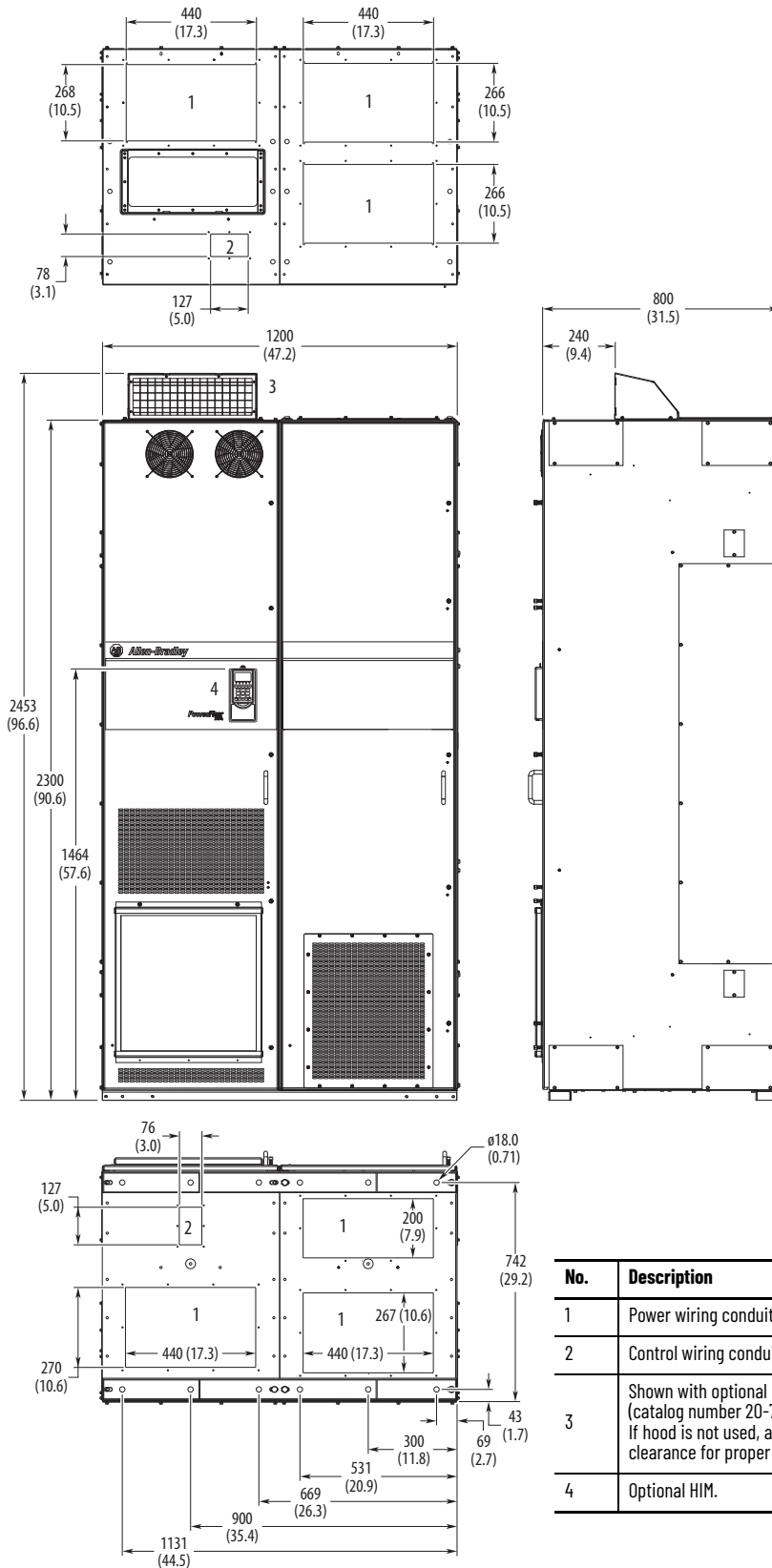

No.	Description
1	Power wiring conduit plates.
2	Control wiring conduit plates.
3	Shown with optional hood (catalog number 20-750-HOOD1-F8). If hood is not used, allow sufficient top clearance for proper airflow. See page 133 .
4	Optional HIM.

Frame Type Approximate Dimensions - mm (in.)

8

MCC Style Cabinet with Cabinet Option Bay, 800 mm (31.5 in.) Deep IP20, NEMA/UL Type 1 Enclosure Codes L, P, W

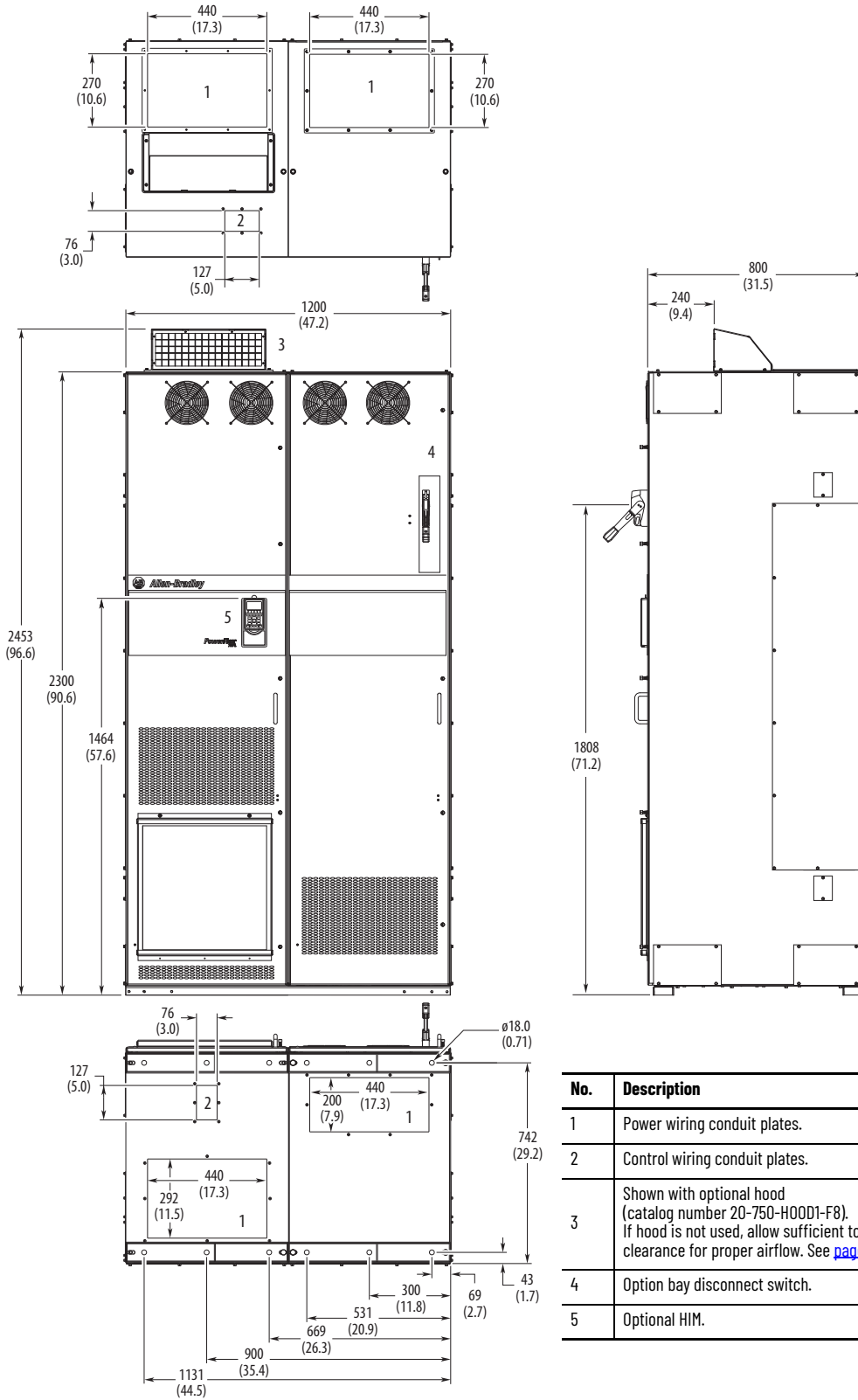

No.	Description
1	Power wiring conduit plates.
2	Control wiring conduit plates.
3	Shown with optional hood (catalog number 20-750-HOOD1-F8). If hood is not used, allow sufficient top clearance for proper airflow. See page 133 .
4	Option bay disconnect switch.
5	Optional HIM.

Frame Type **Approximate Dimensions - mm (in.)**

8

MCC Style Cabinet with Wiring Bay and Cabinet Option Bay, 800 mm (31.5 in.) Deep IP20, NEMA/UL Type 1 Enclosure Code L, P, W

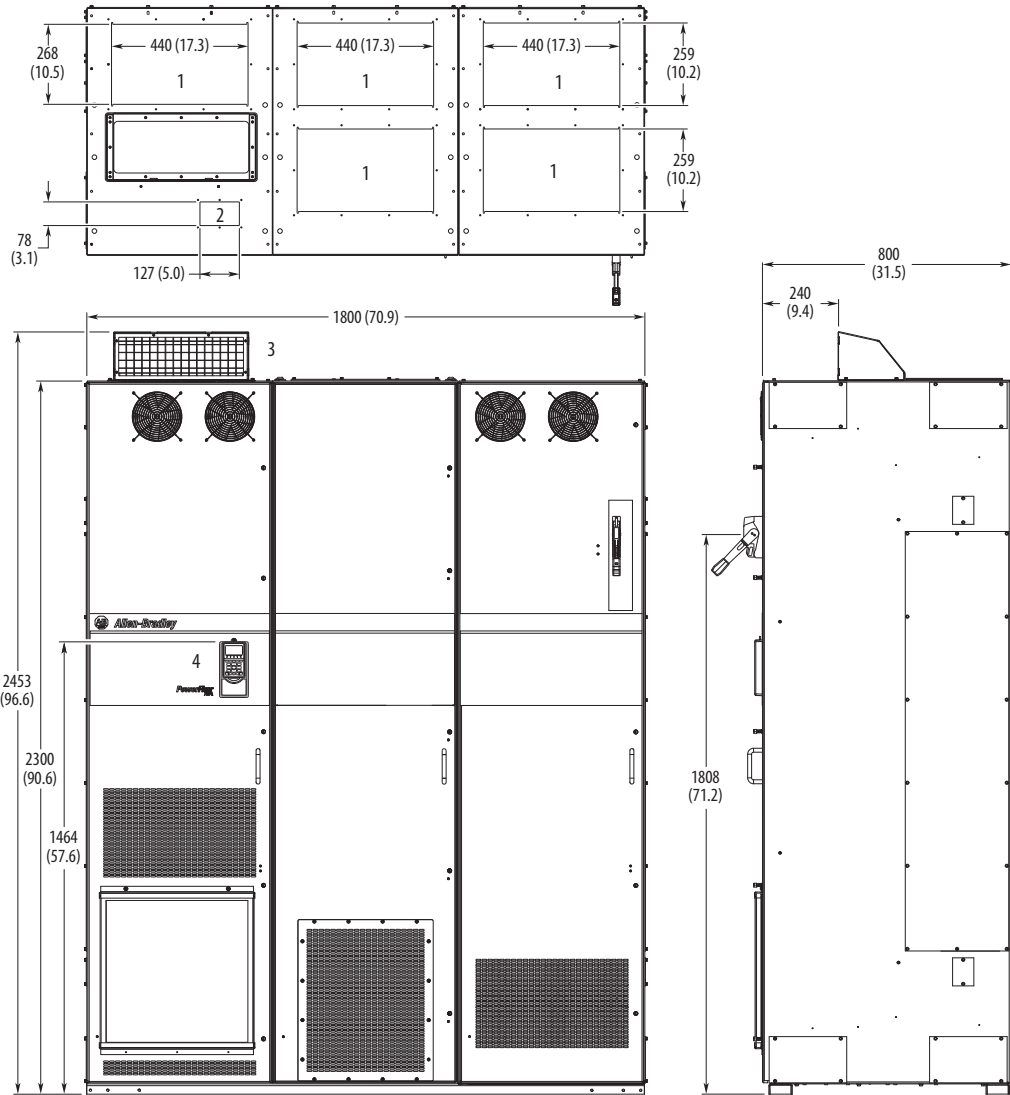

No.	Description
1	Power wiring conduit plates.
2	Control wiring conduit plates.
3	Shown with optional hood (catalog number 20-750-HOOD1-F8). If hood is not used, allow sufficient top clearance for proper airflow. See page 133 .
4	Optional HIM.

Frame Type **Approximate Dimensions - mm (in.)**

8

MCC Style
Cabinet, 800
mm (31.5 in.)
Deep
IP54, NEMA 12
Enclosure
Codes K, Y (DC
Input)
IP54, UL Type 12
Enclosure Code
J
(AC Input)

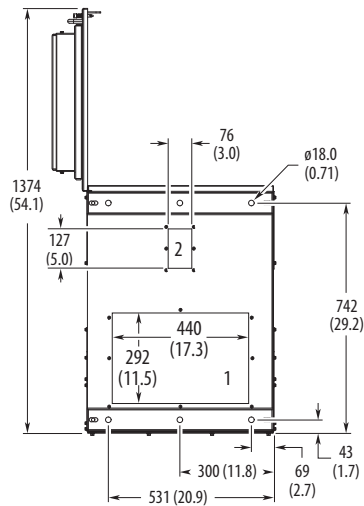
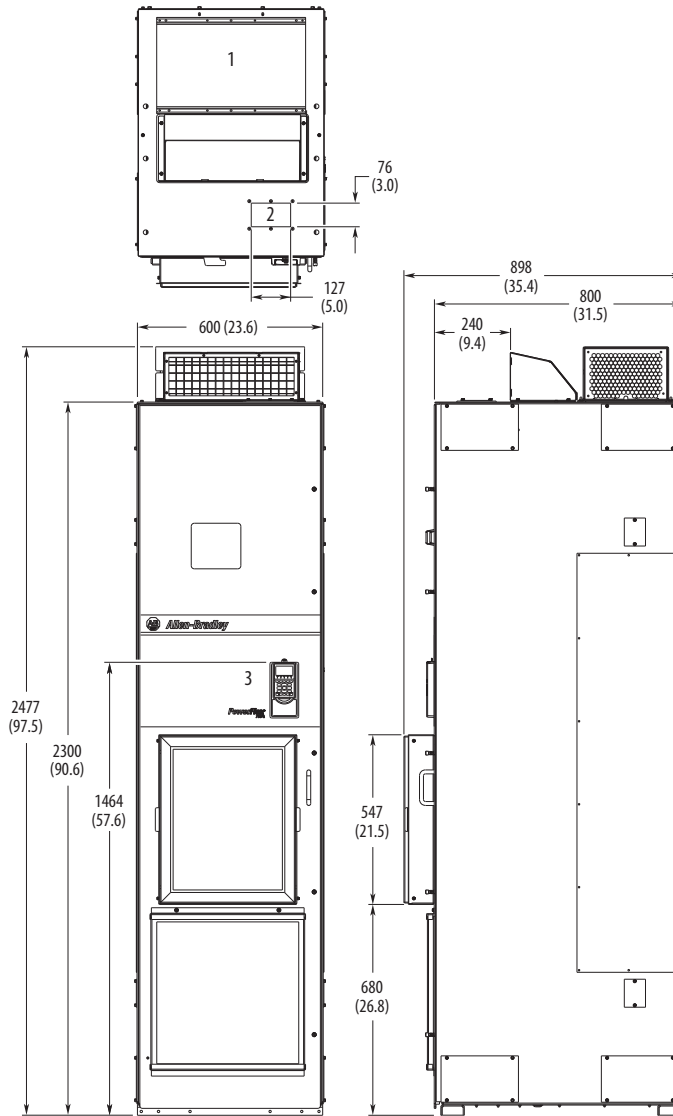

No.	Description
1	Power wiring conduit plates.
2	Control wiring conduit plates.
3	Optional HIM.

Frame Type **Approximate Dimensions - mm (in.)**

8

MCC Style Cabinet with Wiring Bay, 800 mm (31.5 in.) Deep IP54, NEMA 12 Enclosure Codes K, Y (DC Input) IP54, UL Type 12 Enclosure Code J (AC Input)

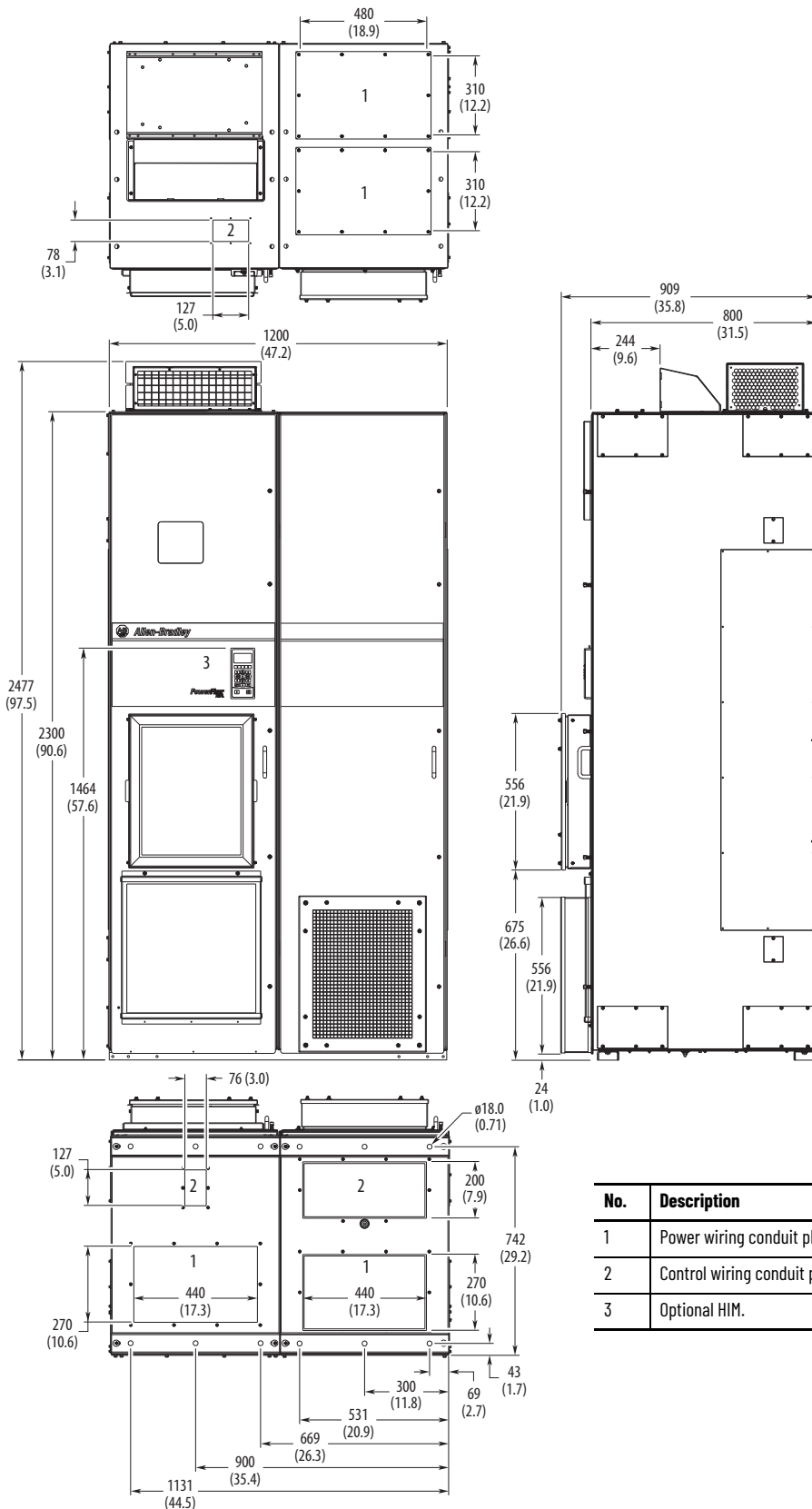

No.	Description
1	Power wiring conduit plates.
2	Control wiring conduit plates.
3	Optional HIM.

Frame Type **Approximate Dimensions - mm (in.)**

8

MCC Style Cabinet with Cabinet Option Bay, 800 mm (31.5 in.) Deep IP54, NEMA 12 Enclosure Codes K, Y (DC Input) IP54, UL Type 12 Enclosure Code J (AC Input)

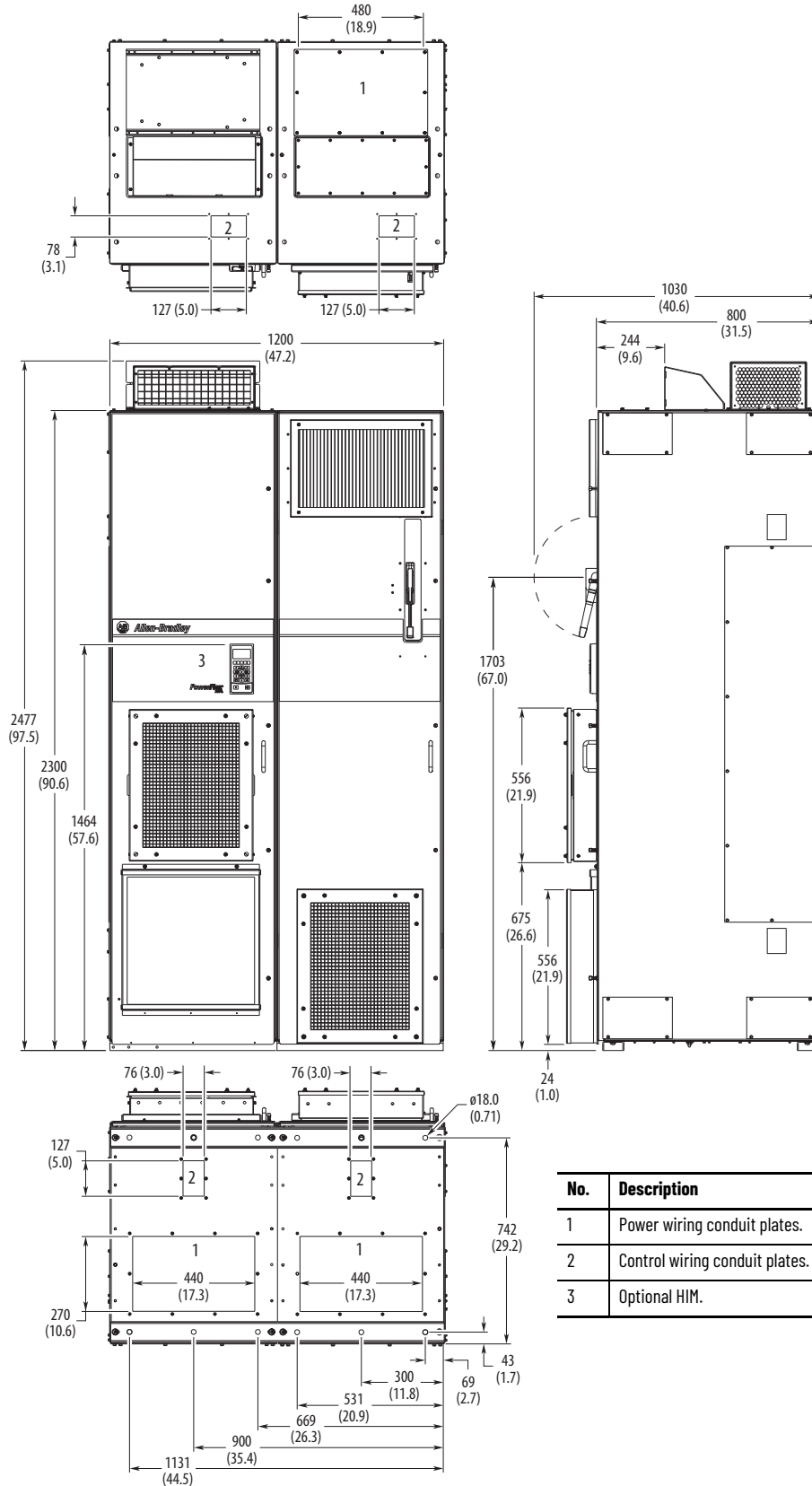

No.	Description
1	Power wiring conduit plates.
2	Control wiring conduit plates.
3	Optional HIM.

Frame Type **Approximate Dimensions - mm (in.)**

8

MCC Style Cabinet with Wiring Bay and Cabinet Option Bay, 800 mm (31.5 in.) Deep IP54, NEMA 12 Enclosure Codes K, Y (DC Input) IP54, UL Type 12 Enclosure Code J (AC Input)

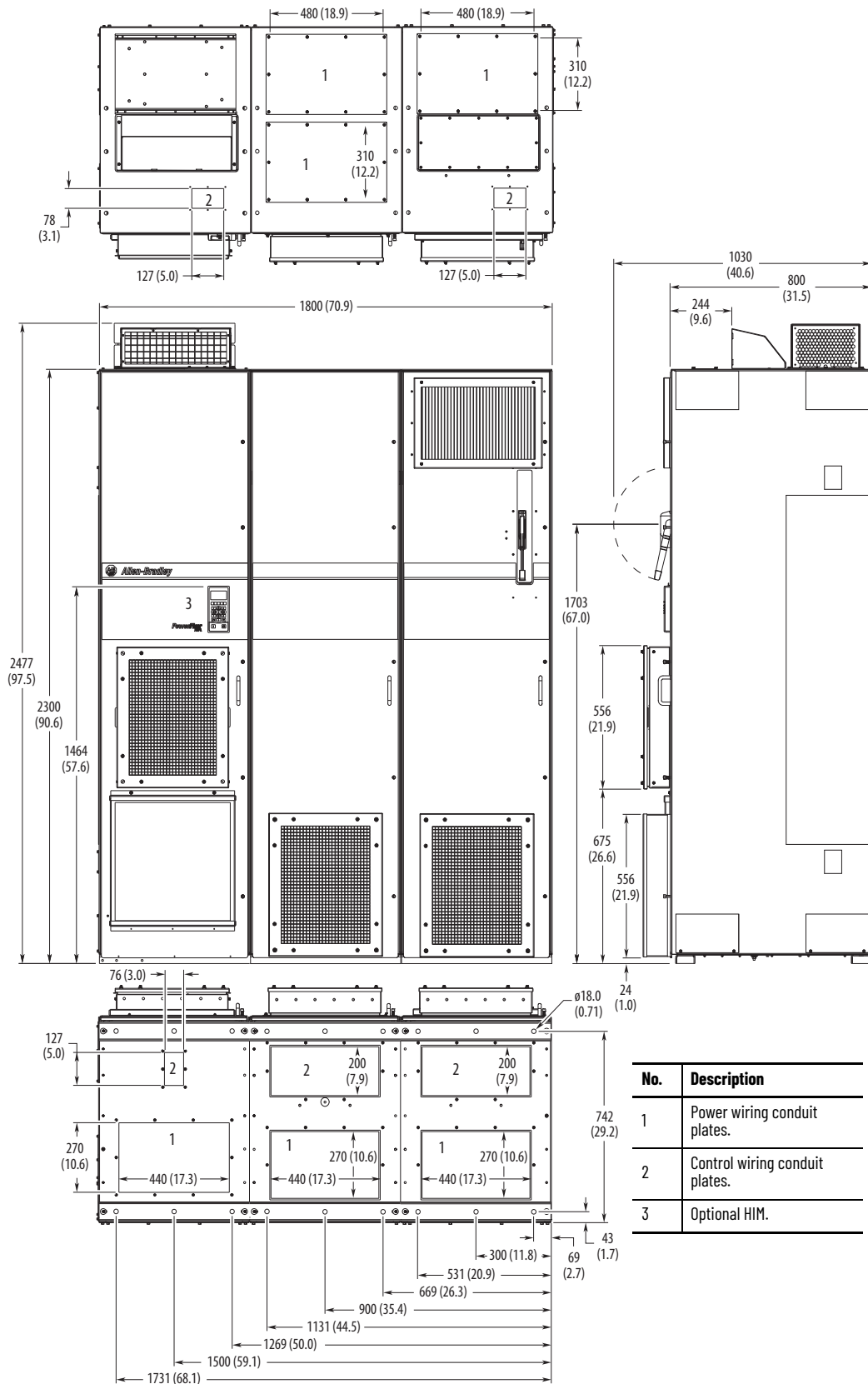

No.	Description
1	Power wiring conduit plates.
2	Control wiring conduit plates.
3	Optional HIM.

Frame Type **Approximate Dimensions - mm (in.)**

8

Open Style
IPOD, NEMA/UL
Open Type
Enclosure Code
T
(AC Input)

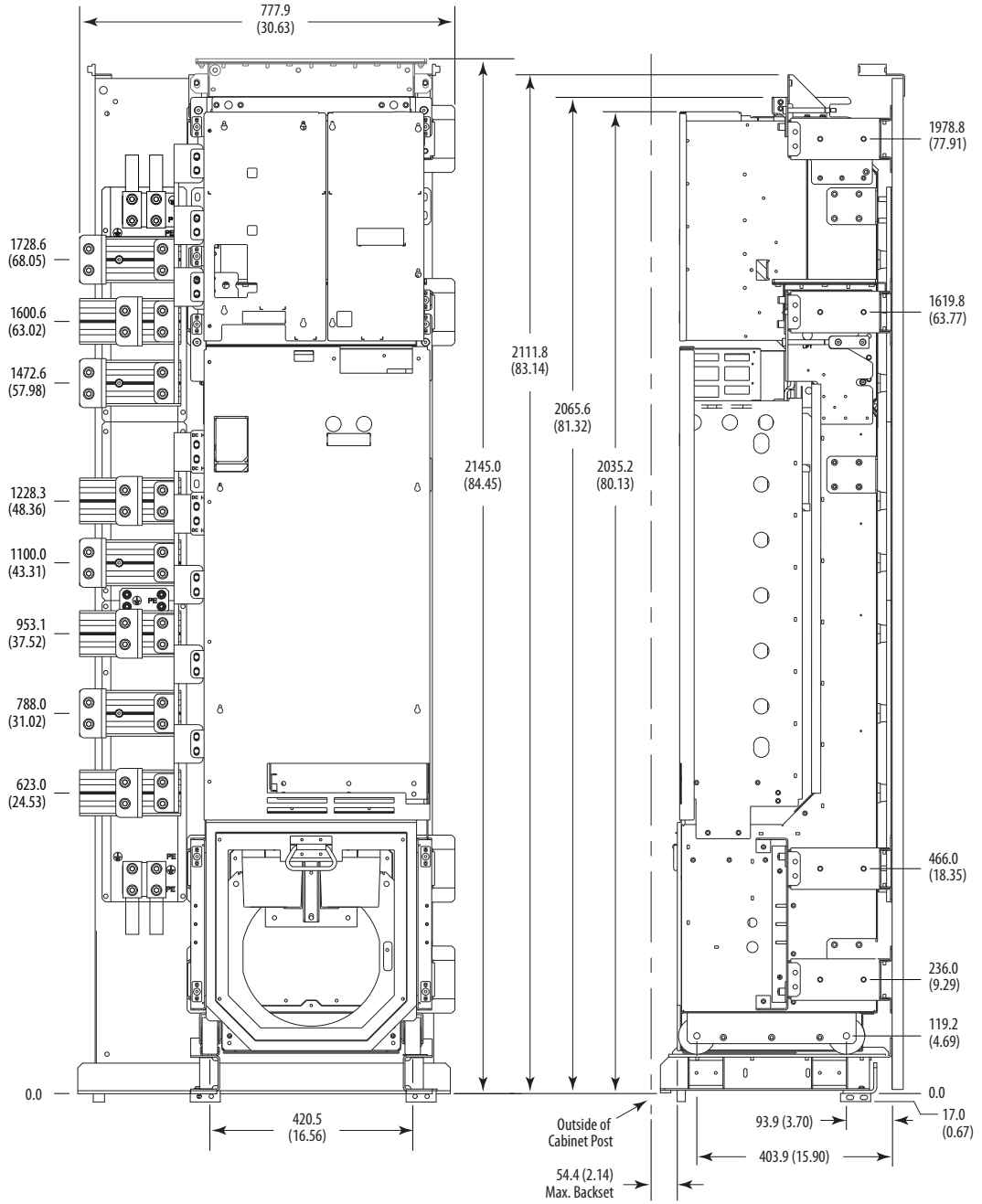

Frame Type Approximate Dimensions - mm (in.)

8

Open Style
IPOO, NEMA/UL
Open Type
Enclosure Code
T
(DC Input)

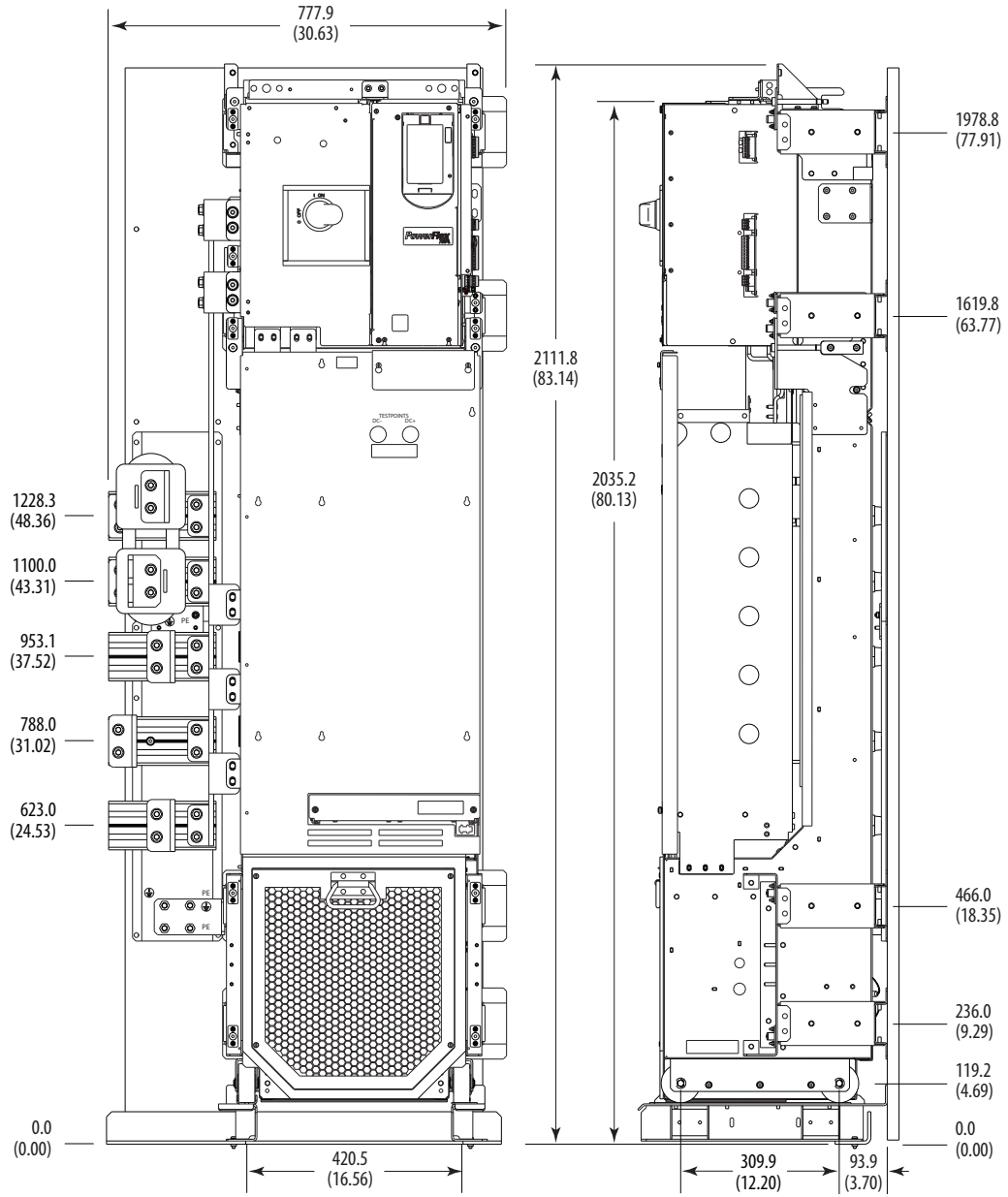

Frame Type **Approximate Dimensions - mm (in.)**

9

MCC Style
Cabinet, 600
mm (23.6 in.)
Deep
IP20, NEMA/UL
Type 1
Enclosure Code
B

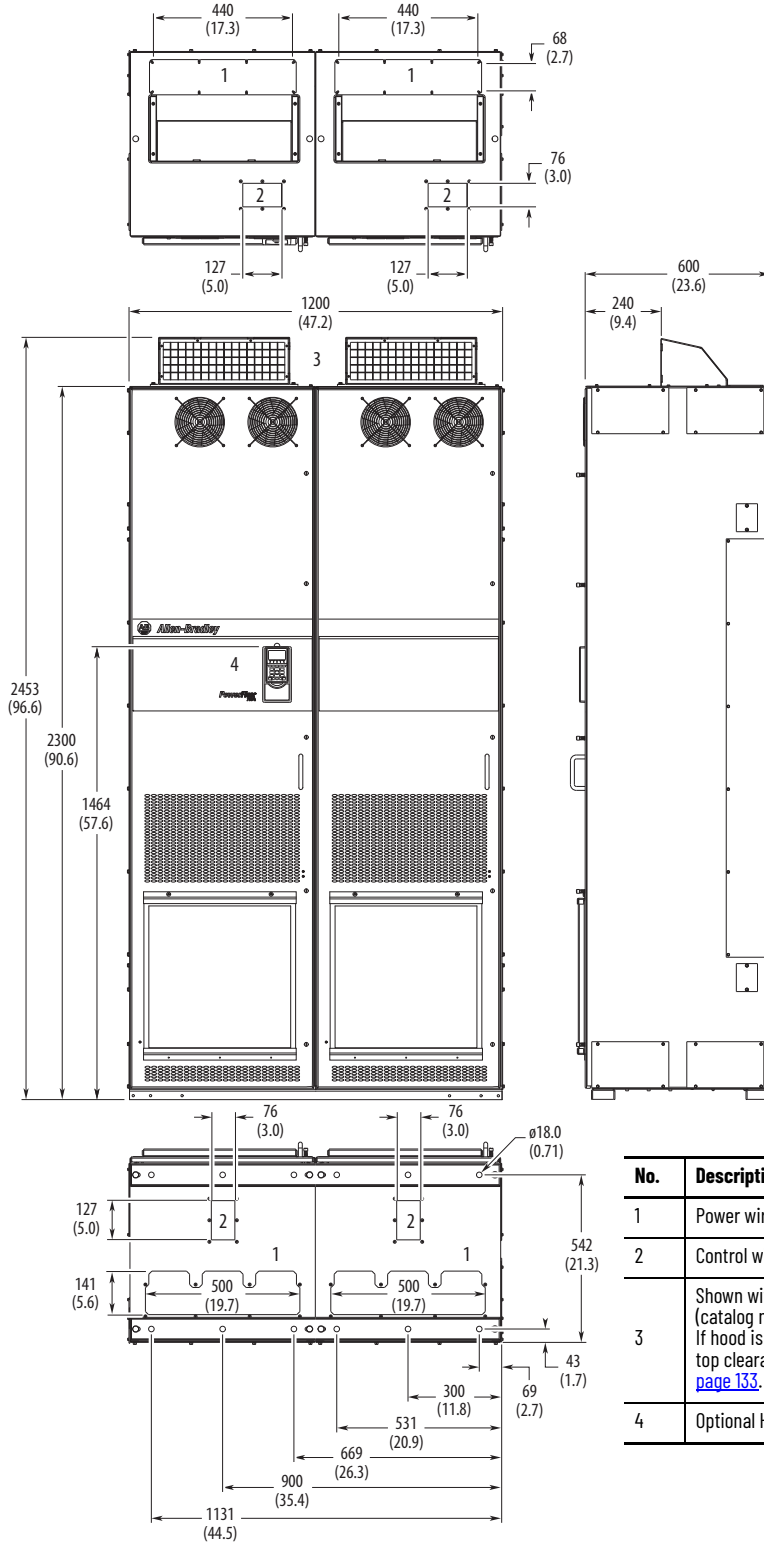

No.	Description
1	Power wiring conduit plates.
2	Control wiring conduit plates.
3	Shown with optional hood (catalog number 20-750-HOOD1-F8). If hood is not used, allow sufficient top clearance for proper airflow. See page 133 .
4	Optional HIM.

Frame Type **Approximate Dimensions - mm (in.)**

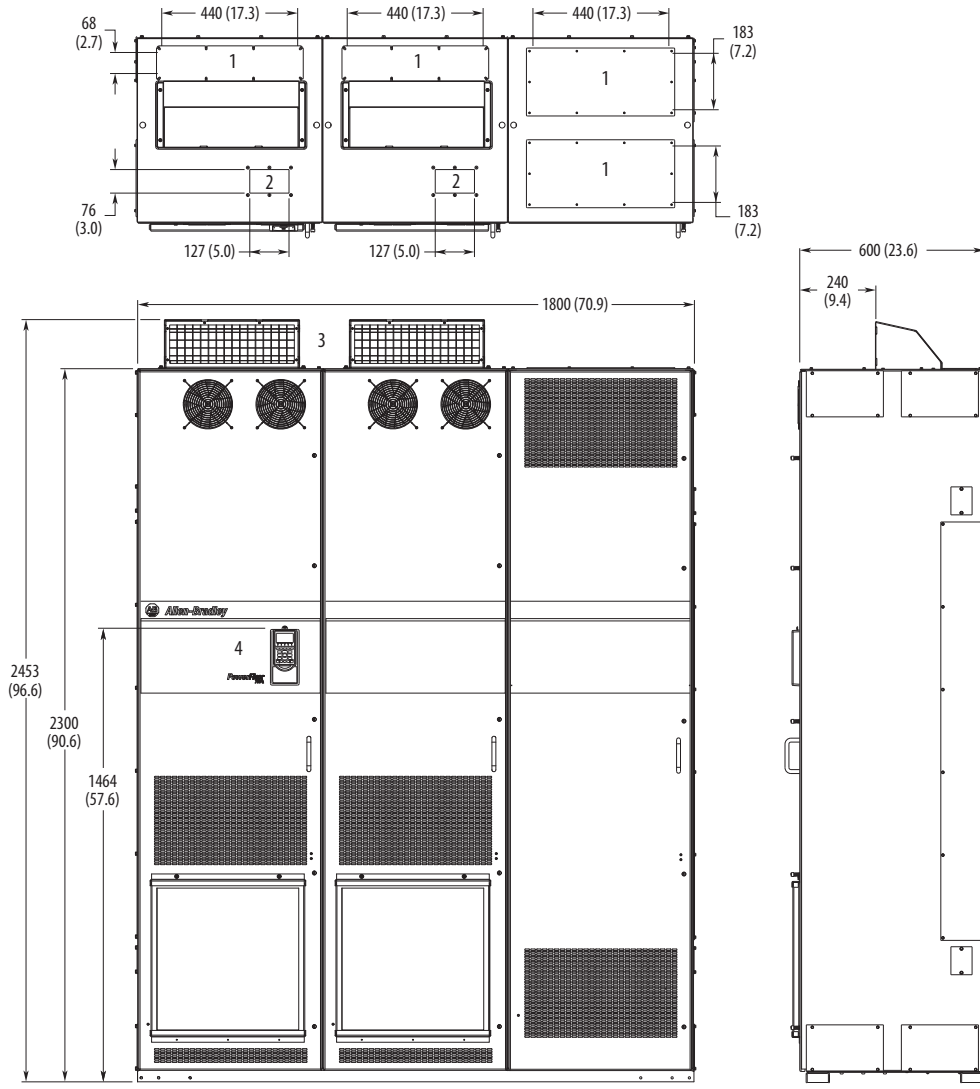

MCC Style Cabinet with Wiring Bay, 600 mm (23.6 in.) Deep IP20, NEMA/UL Type 1 Enclosure Code B

9

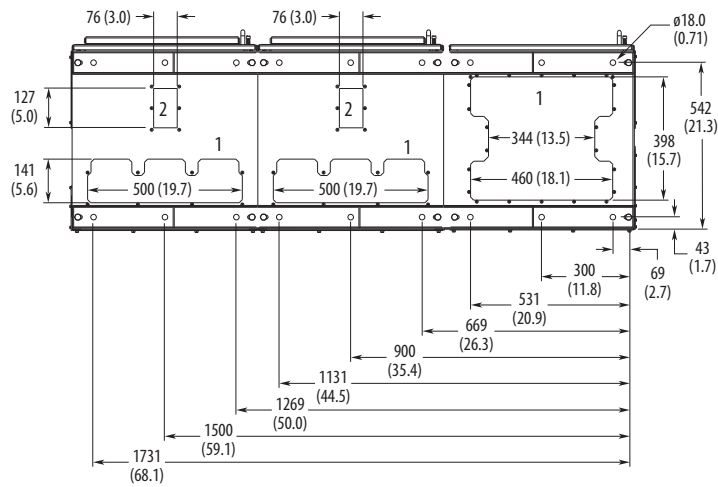

No.	Description
1	Power wiring conduit plates.
2	Control wiring conduit plates.
3	Shown with optional hood (catalog number 20-750-HOOD1-F8). If hood is not used, allow sufficient top clearance for proper airflow. See page 133 .

Frame Type Approximate Dimensions - mm (in.)

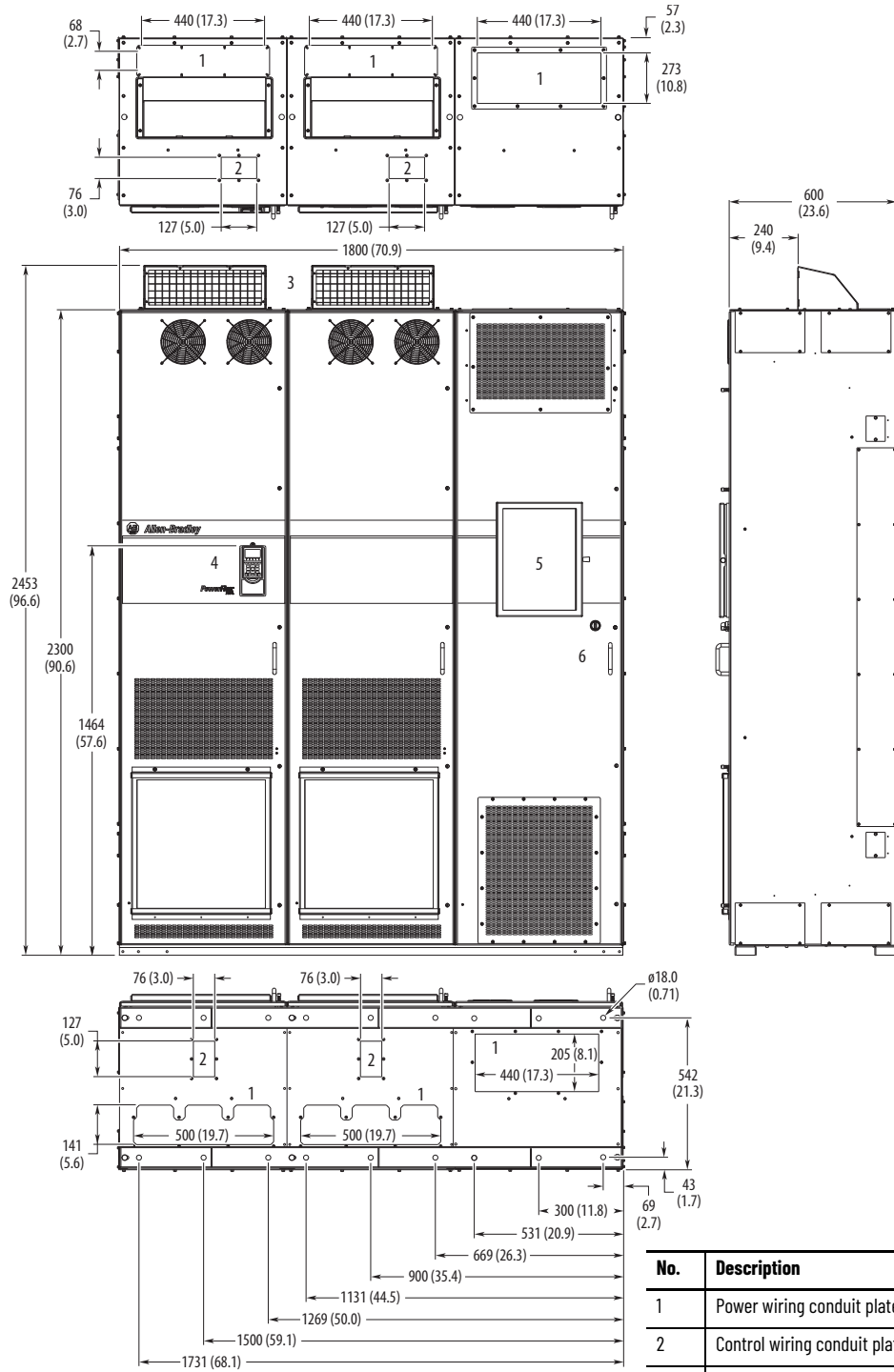

MCC Style Cabinet with Cabinet Option Bay, 600 mm (23.6 in.) Deep IP20, NEMA/UL Type 1 Enclosure Code L (AC Input) Enclosure Codes P, W (DC Input)

9

No.	Description
1	Power wiring conduit plates.
2	Control wiring conduit plates.
3	Shown with optional hood (catalog number 20-750-HOOD1-F8). If hood is not used, allow sufficient top clearance for proper airflow. See page 133.
4	Optional HIM.
5	Option bay disconnect switch access door.
6	Interlock override switch.

Frame Type **Approximate Dimensions - mm (in.)**

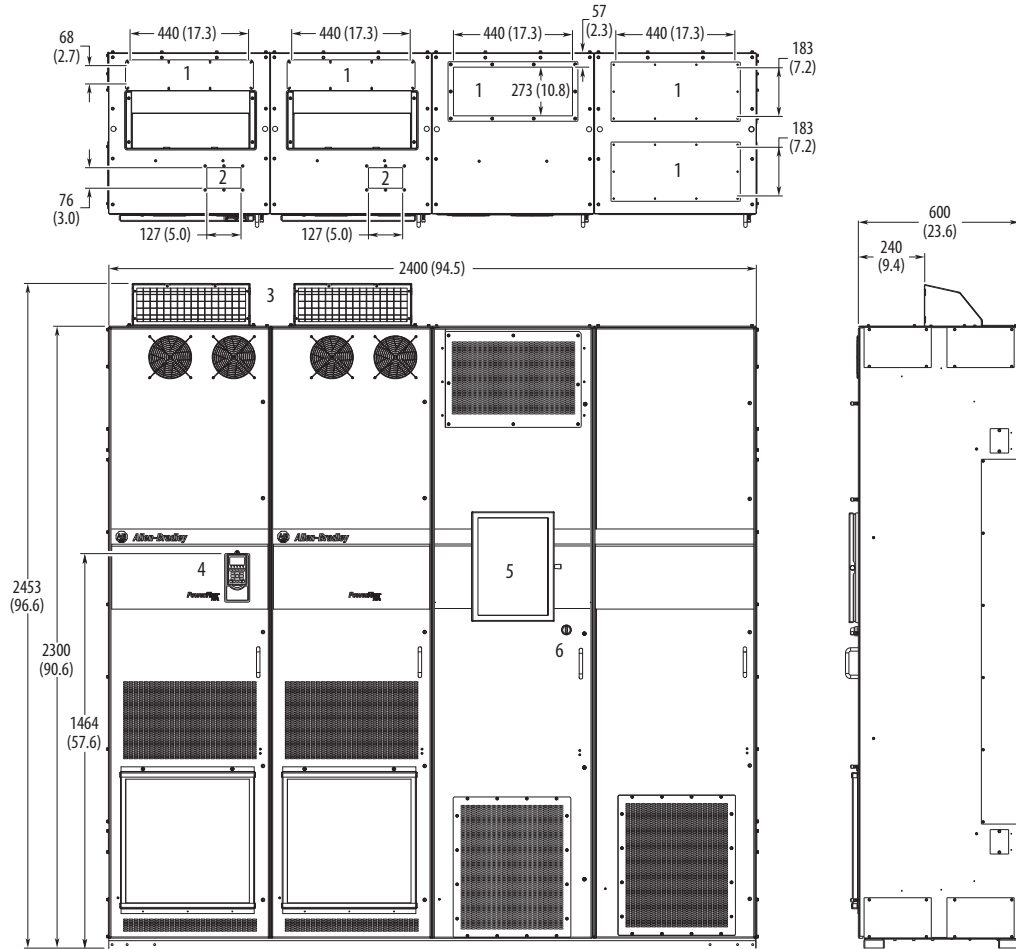

9

MCC Style Cabinet with Cabinet Option Bay and Wiring Bay, 600 mm (23.6 in.) Deep IP20, NEMA/UL Type 1 Enclosure Codes L, P, W

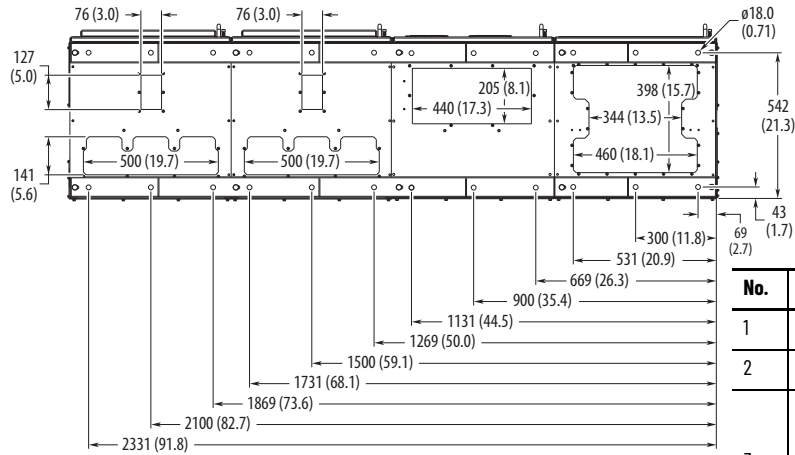

No.	Description
1	Power wiring conduit plates.
2	Control wiring conduit plates.
3	Shown with optional hood (catalog number 20-750-HOOD1-F8). If hood is not used, allow sufficient top clearance for proper airflow. See page 133 .
4	Optional HIM.
5	Option bay disconnect switch access door.
6	Interlock override switch.

Frame Type **Approximate Dimensions - mm (in.)**

9

MCC Style Cabinet, 800 mm (31.5 in.) Deep
 IP20, NEMA/UL Type 1
 Enclosure Code L (AC Input)
 Enclosure Codes P, W (DC Input)

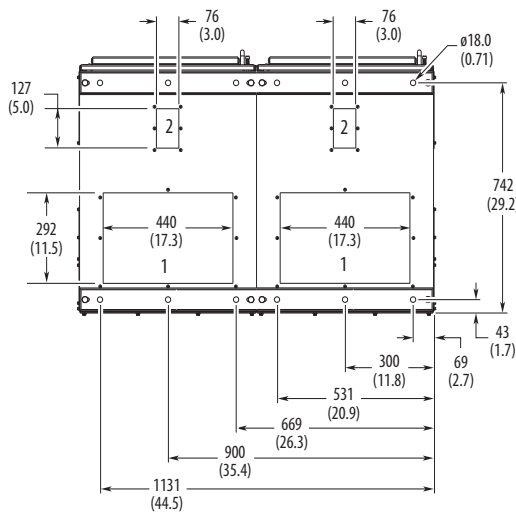
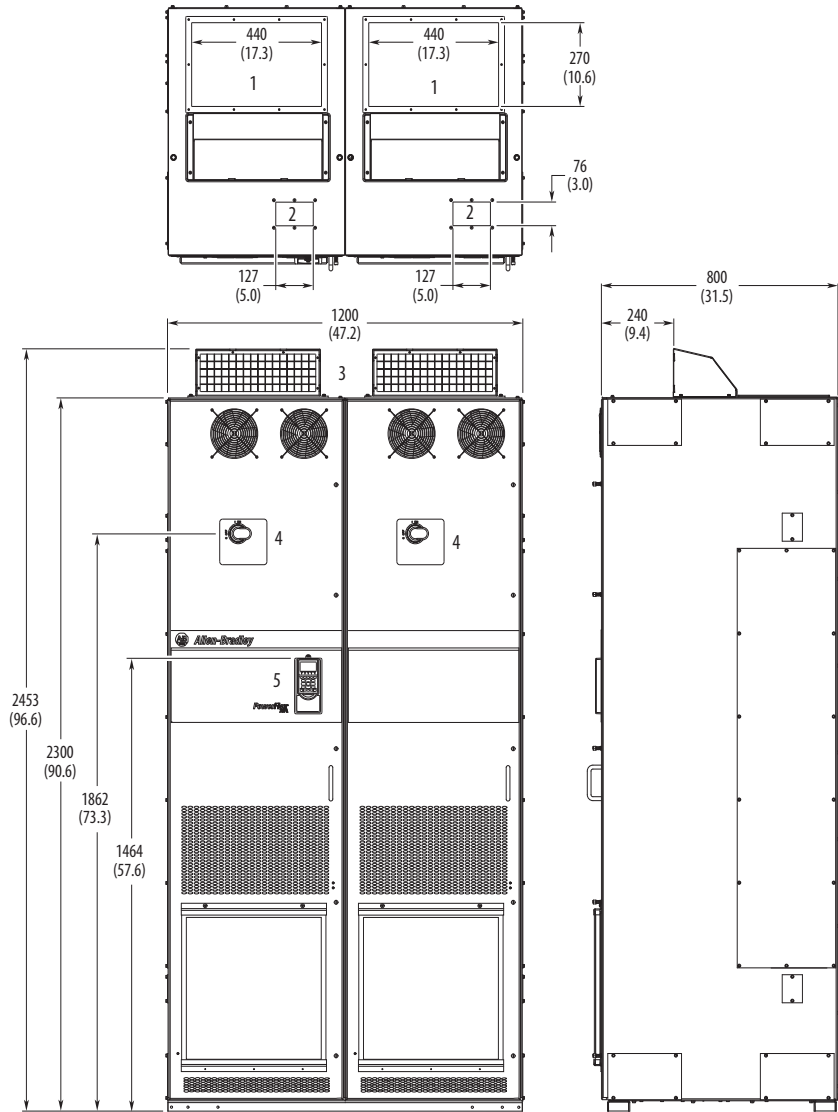

No.	Description
1	Power wiring conduit plates.
2	Control wiring conduit plates.
3	Shown with optional hood (catalog number 20-750-HOOD1-F8). If hood is not used, allow sufficient top clearance for proper airflow. See page 133 .
4	Disconnect switches - Common DC Input drives.
5	Optional HIM.

Frame Type **Approximate Dimensions - mm (in.)**

9

MCC Style Cabinet with Wiring Bay, 800 mm (31.5 in.) Deep IP20, NEMA/UL Type 1 Enclosure Code L (AC Input) Enclosure Codes P, W (DC Input)

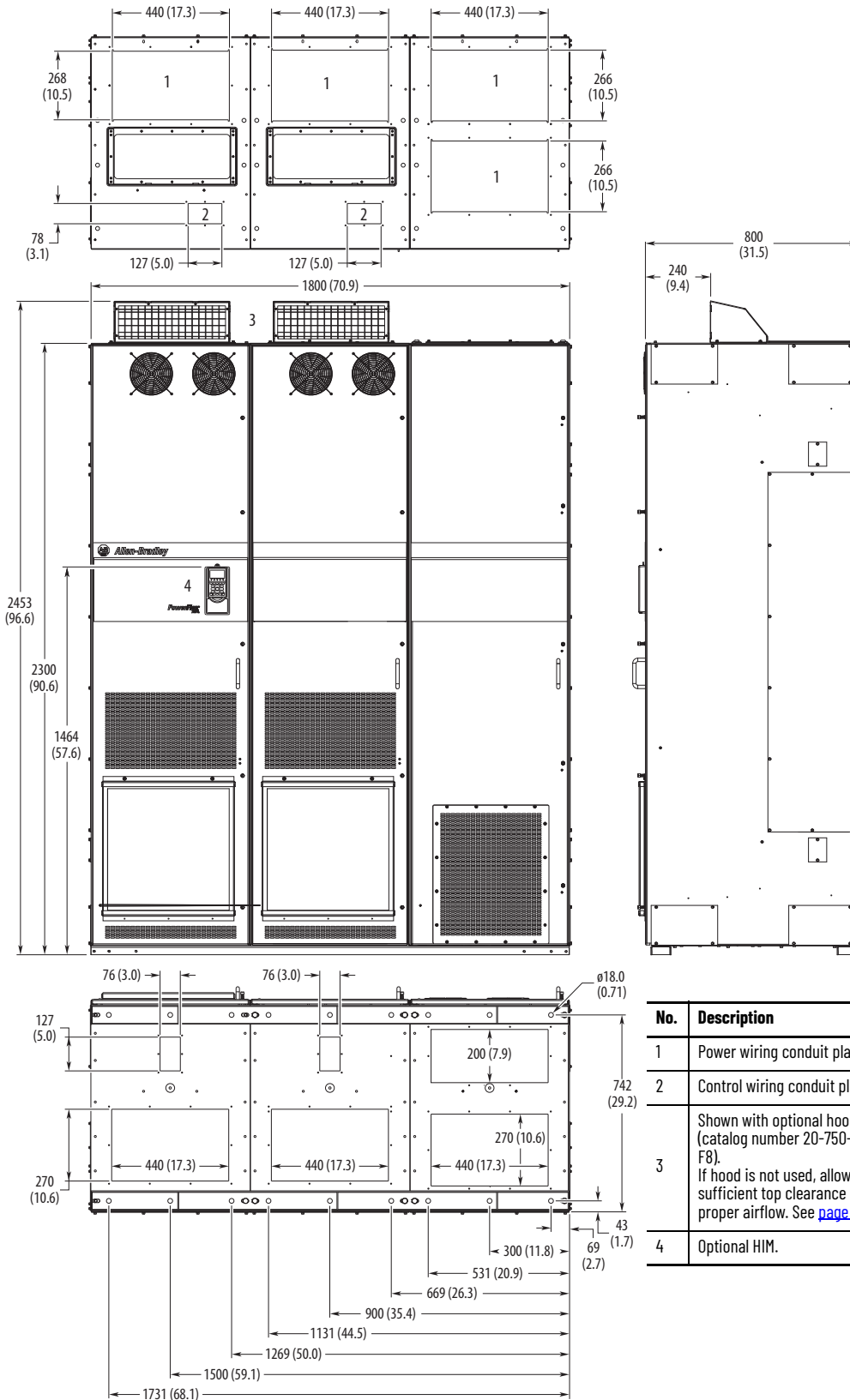

No.	Description
1	Power wiring conduit plates.
2	Control wiring conduit plates.
3	Shown with optional hood (catalog number 20-750-HOOD1-F8). If hood is not used, allow sufficient top clearance for proper airflow. See page 133 .
4	Optional HIM.

Frame Type **Approximate Dimensions - mm (in.)**

9

MCC Style Cabinet with Cabinet Option Bay, 800 mm (31.5 in.) Deep IP20, NEMA/UL Type 1 Enclosure Code L (AC Input) Enclosure Codes P, W (DC Input)

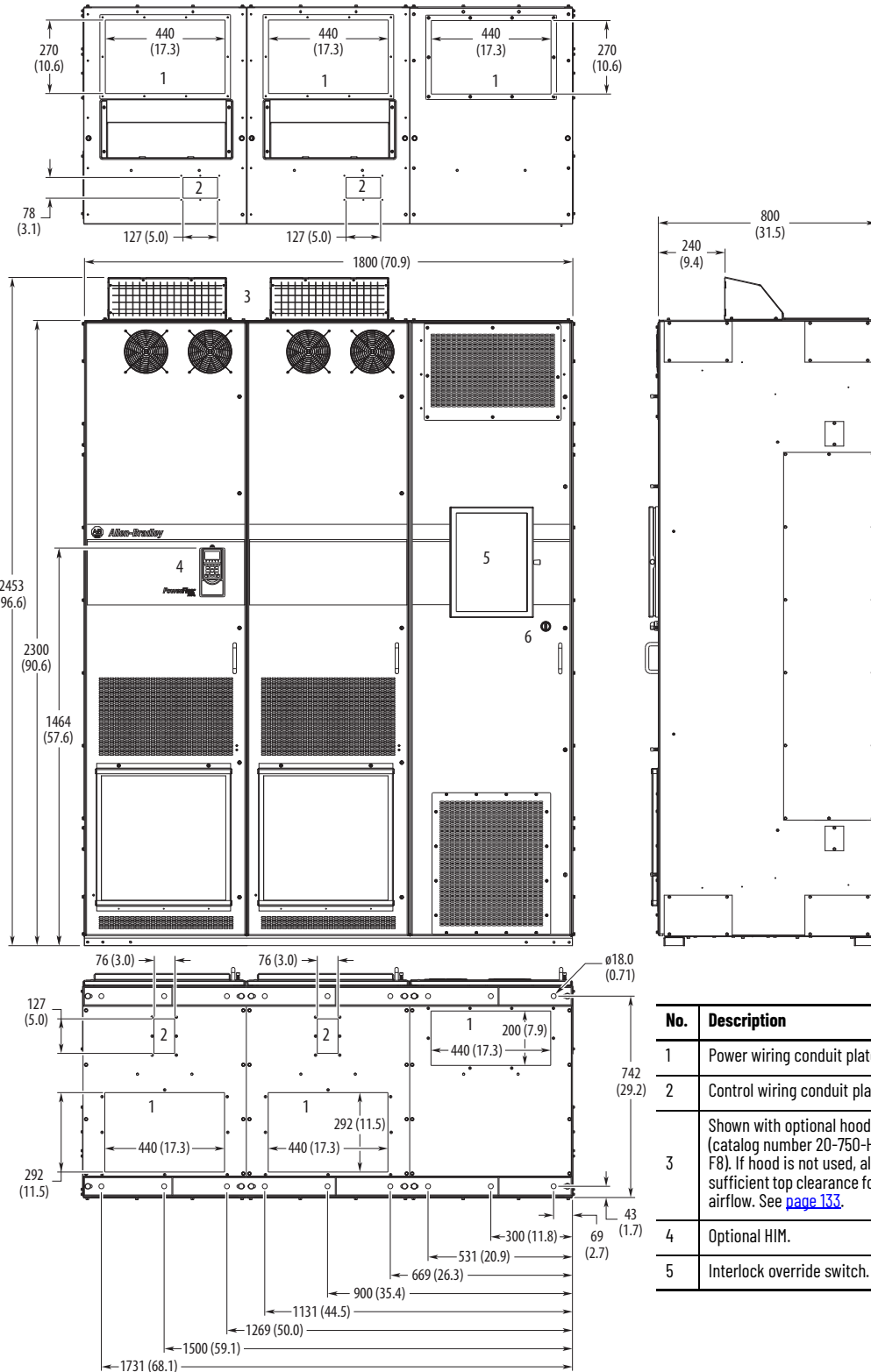

No.	Description
1	Power wiring conduit plates.
2	Control wiring conduit plates.
3	Shown with optional hood (catalog number 20-750-HOOD1-F8). If hood is not used, allow sufficient top clearance for proper airflow. See page 133 .
4	Optional HIM.
5	Interlock override switch.

Frame Type **Approximate Dimensions - mm (in.)**

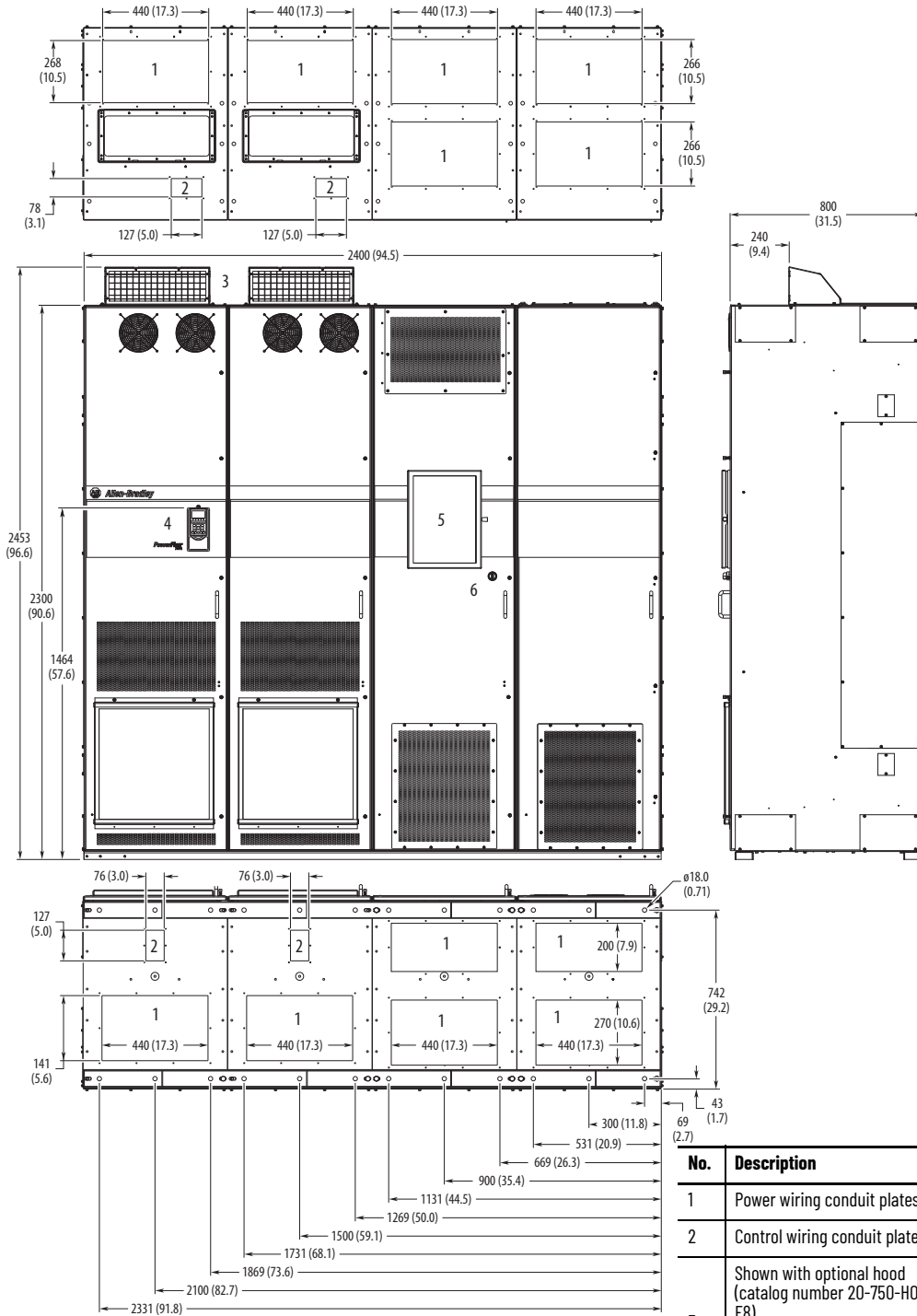

MCC Style Cabinet with Cabinet Option Bay and Wiring Bay, 800 mm (31.5 in.) Deep IP20, NEMA/UL Type 1 Enclosure Code L (AC Input) Enclosure Codes P, W (DC Input)

9

No.	Description
1	Power wiring conduit plates.
2	Control wiring conduit plates.
3	Shown with optional hood (catalog number 20-750-HOOD1-F8). If hood is not used, allow sufficient top clearance for proper airflow. See page 133 .
4	Optional HIM.
5	Option bay disconnect switch access door.
6	Interlock override switch.

Frame Type Approximate Dimensions - mm (in.)

9

MCC Style Cabinet,
800 mm (31.5 in.) Deep
IP54, NEMA 12 Enclosure
Codes K, Y (DC Input)
IP54, UL Type 12 Enclosure Code
J (AC Input)

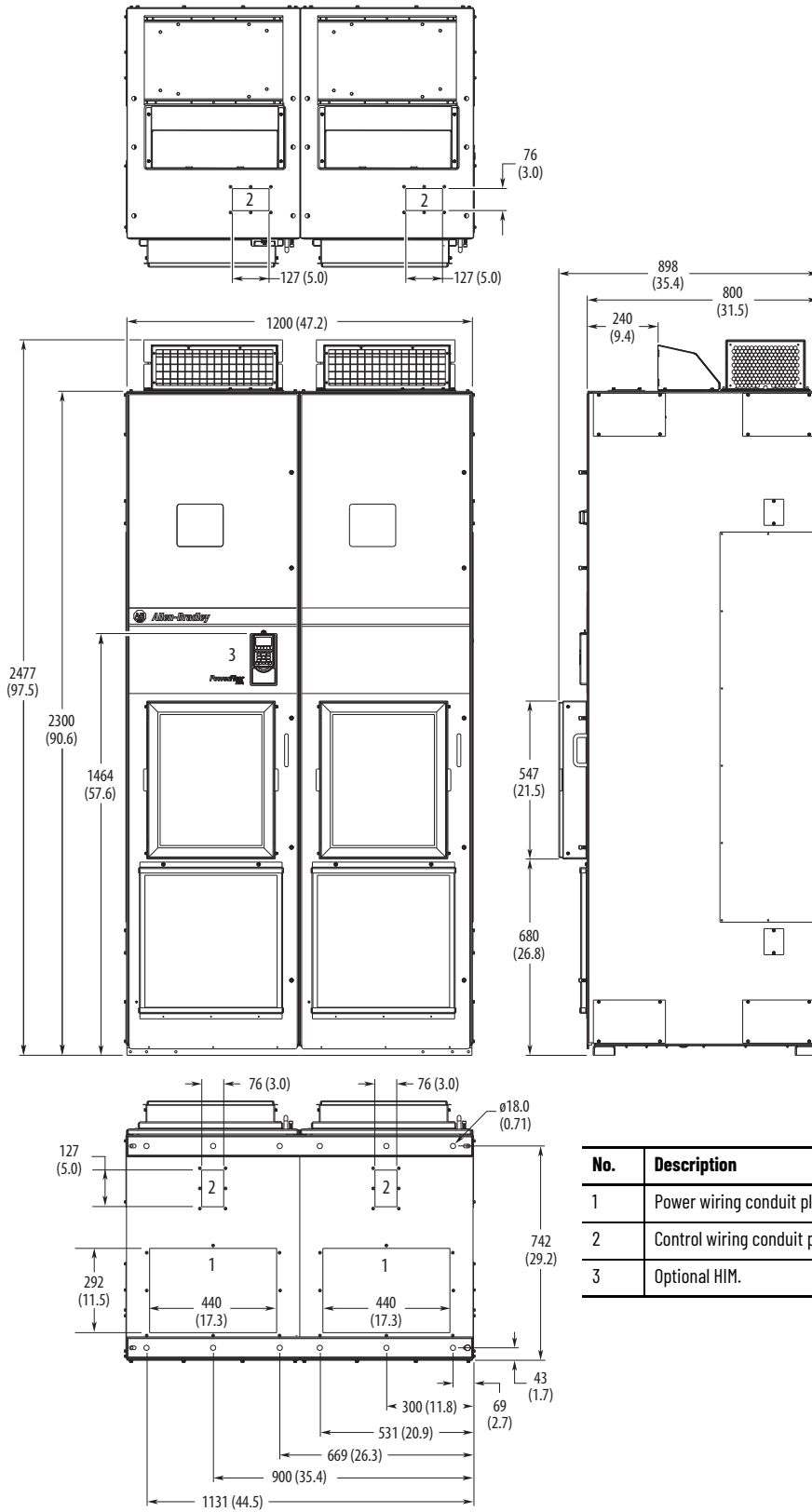

No.	Description
1	Power wiring conduit plates.
2	Control wiring conduit plates.
3	Optional HIM.

Frame Type **Approximate Dimensions - mm (in.)**

9

MCC Style Cabinet with Wiring Bay, 800 mm (31.5 in.) Deep IP54, NEMA 12 Enclosure Codes K, Y IP54, UL Type 12 Enclosure Code J

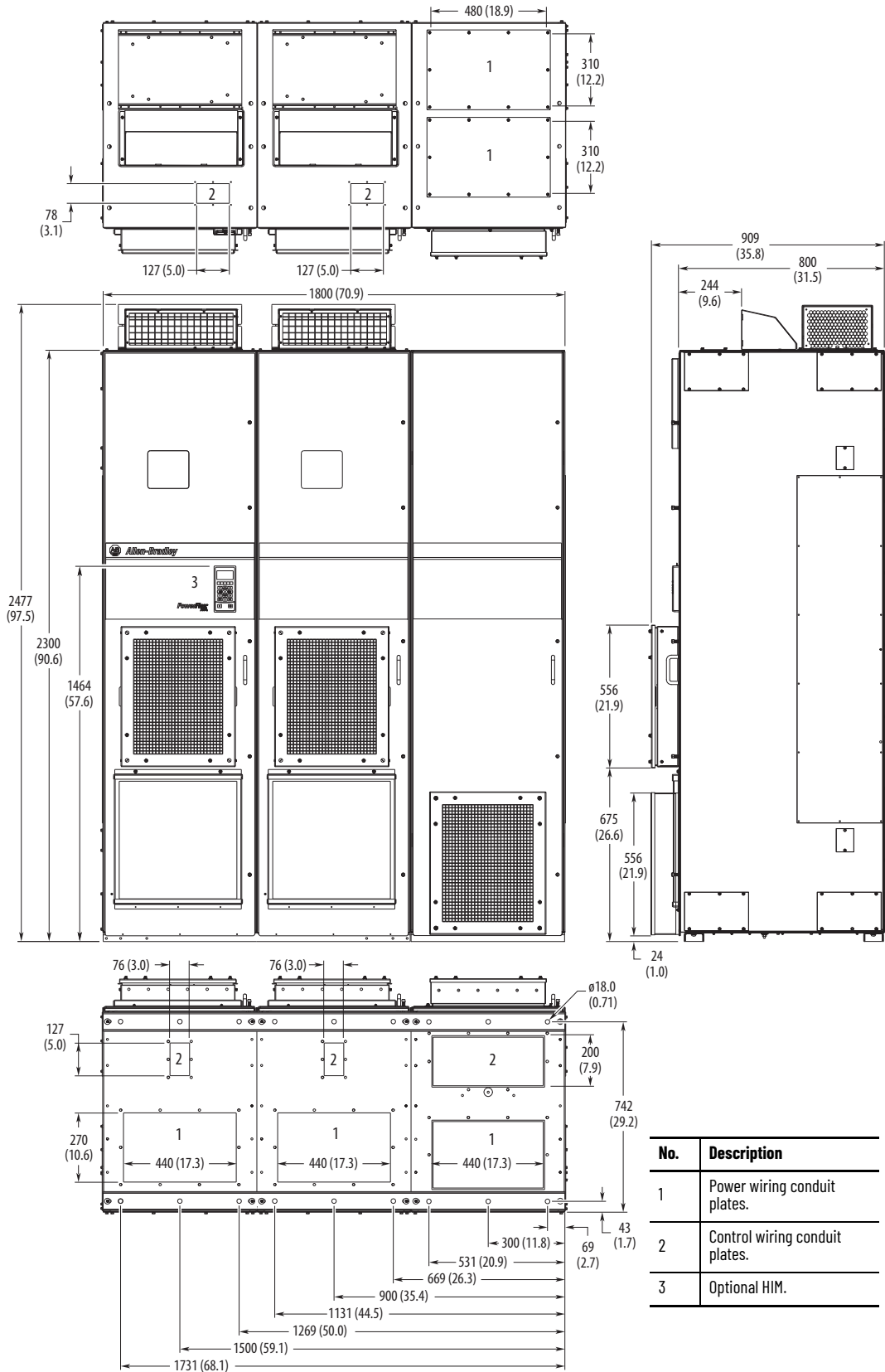

No.	Description
1	Power wiring conduit plates.
2	Control wiring conduit plates.
3	Optional HIM.

Frame Type **Approximate Dimensions - mm (in.)**

9

MCC Style Cabinet with Cabinet Option Bay, 800 mm (31.5 in.) Deep IP54, NEMA 12 Enclosure Codes K, Y IP54, UL Type 12 Enclosure Code J

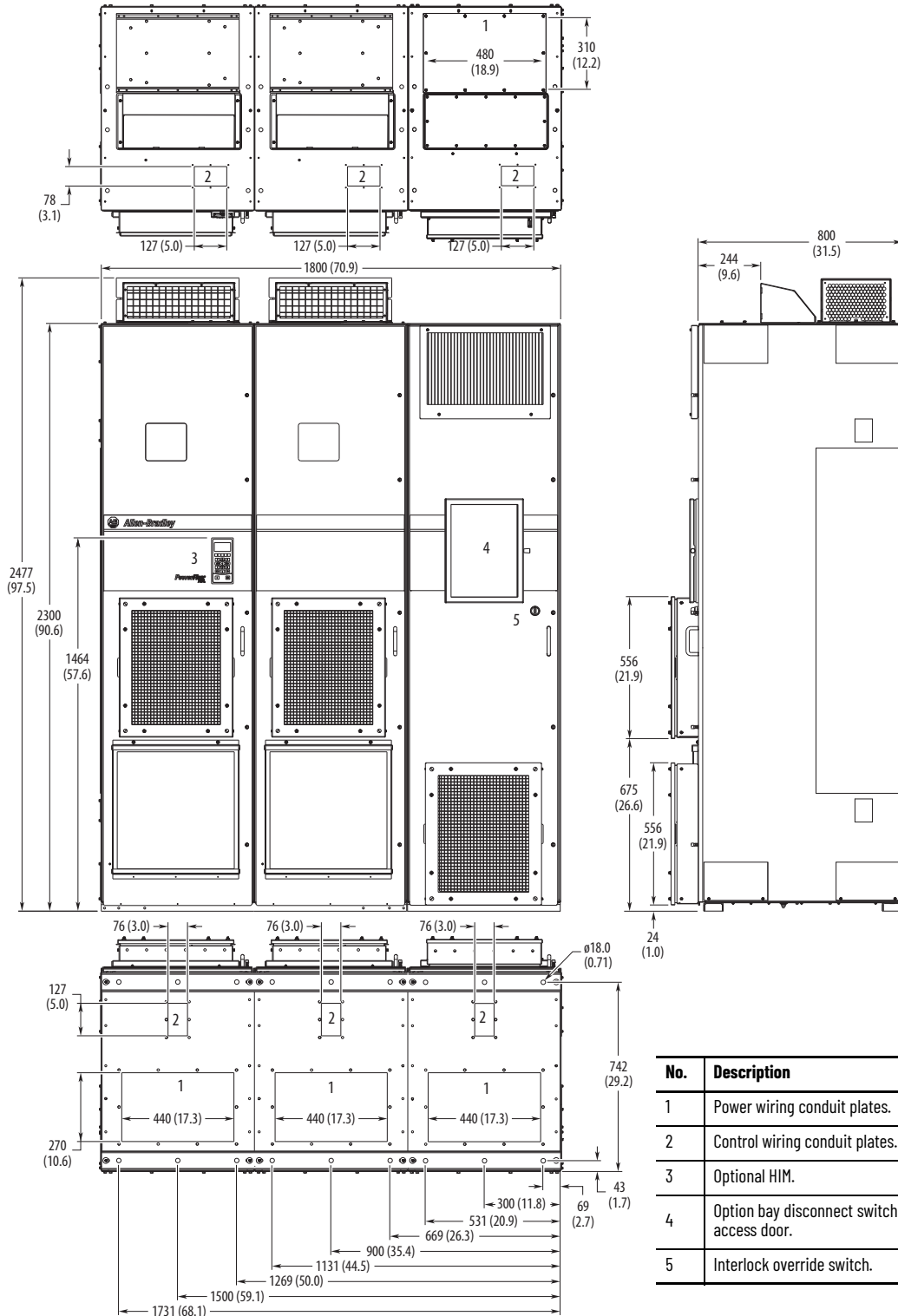

No.	Description
1	Power wiring conduit plates.
2	Control wiring conduit plates.
3	Optional HIM.
4	Option bay disconnect switch access door.
5	Interlock override switch.

Frame Type **Approximate Dimensions - mm (in.)**

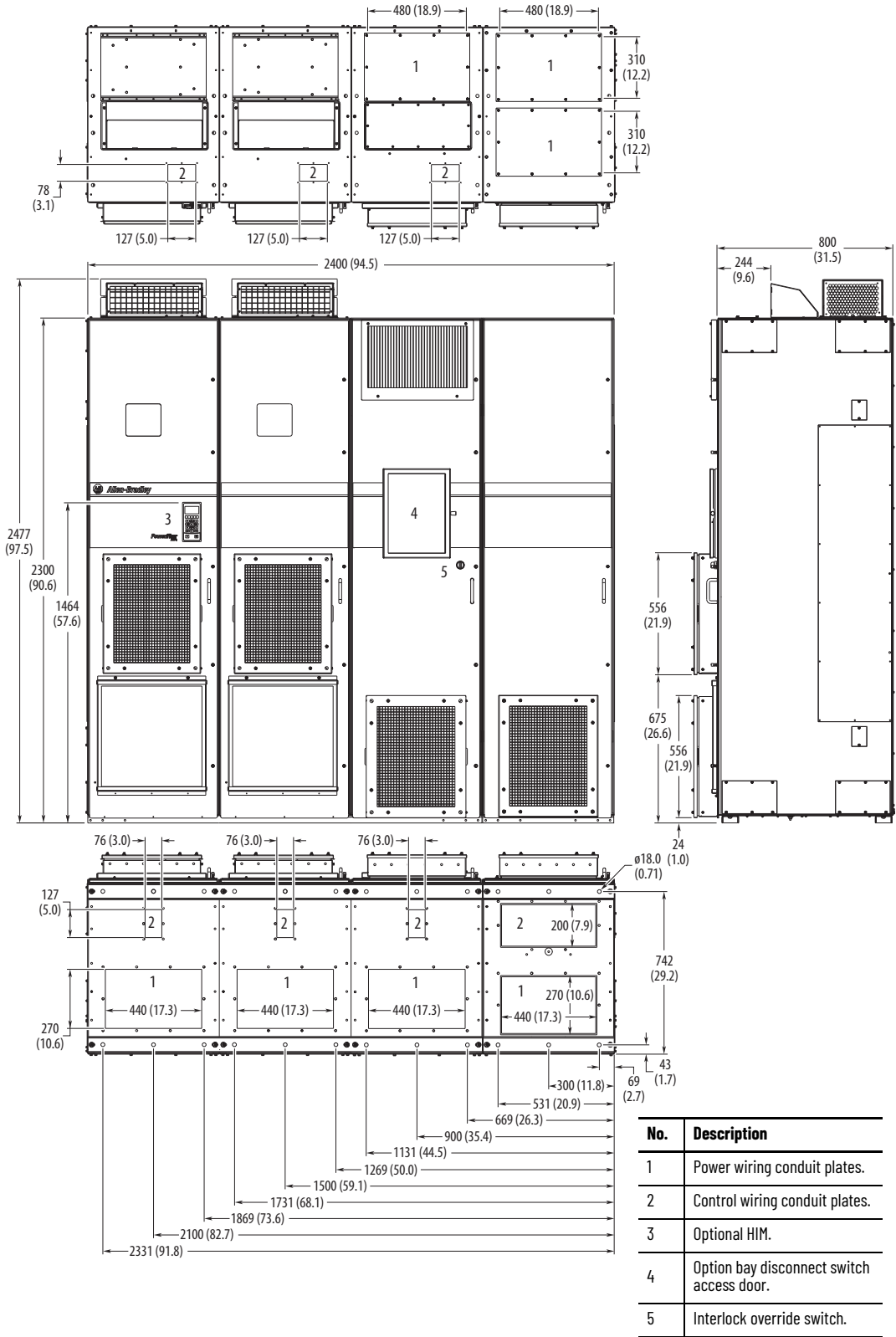

MCC Style Cabinet with Cabinet Option Bay and Wiring Bay, 800 mm (31.5 in.) Deep IP54, NEMA 12 Enclosure Codes K, Y IP54, UL Type 12 Enclosure Code J

9

Frame Type Approximate Dimensions - mm (in.)

9

Open Style
IPOO, NEMA/UL
Open Type
Enclosure Code
T
(AC Input)

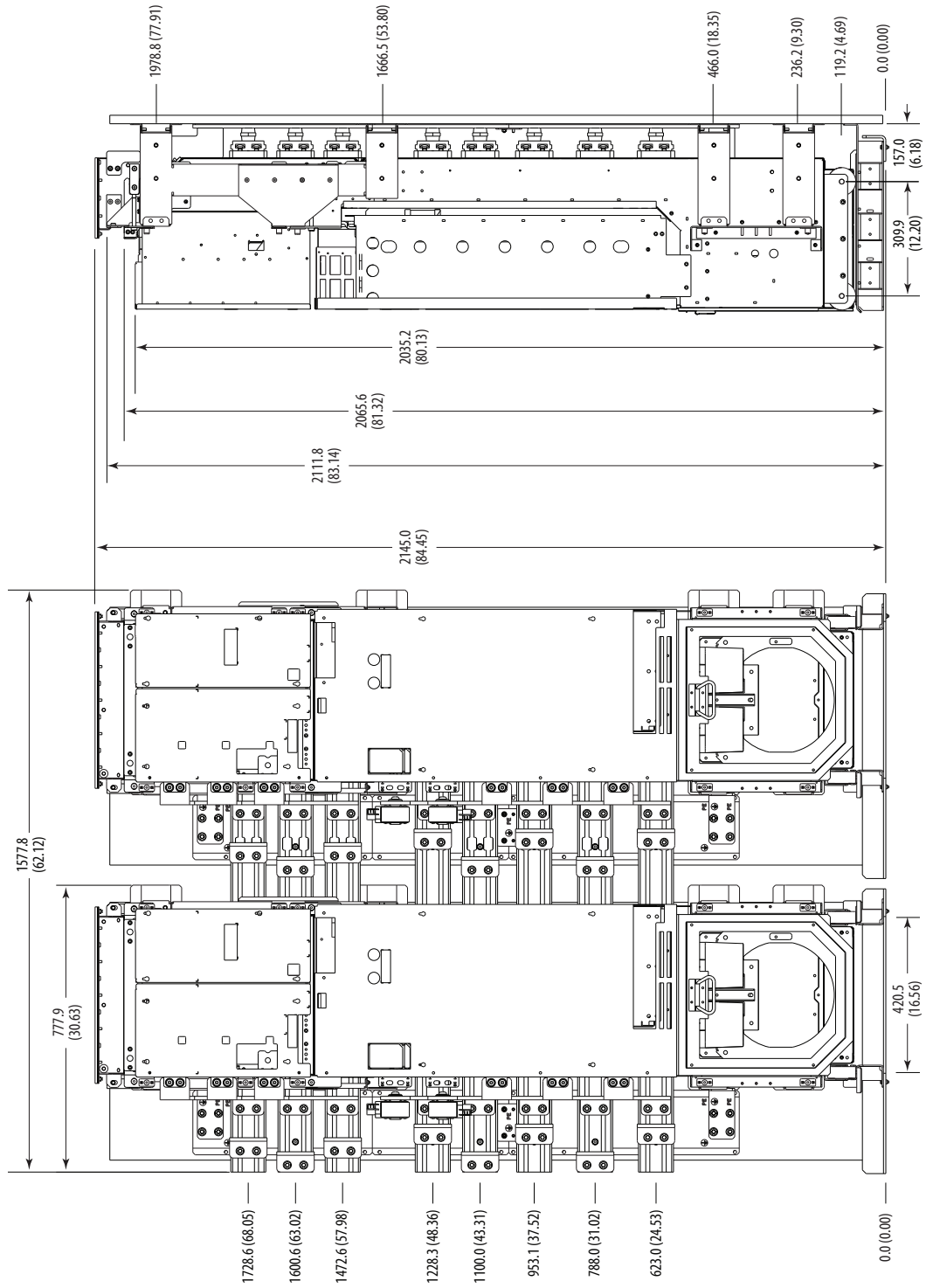

Frame Type Approximate Dimensions - mm (in.)

9

Open Style
IPOO, NEMA/UL
Open Type
Enclosure Code
T
(DC Input)

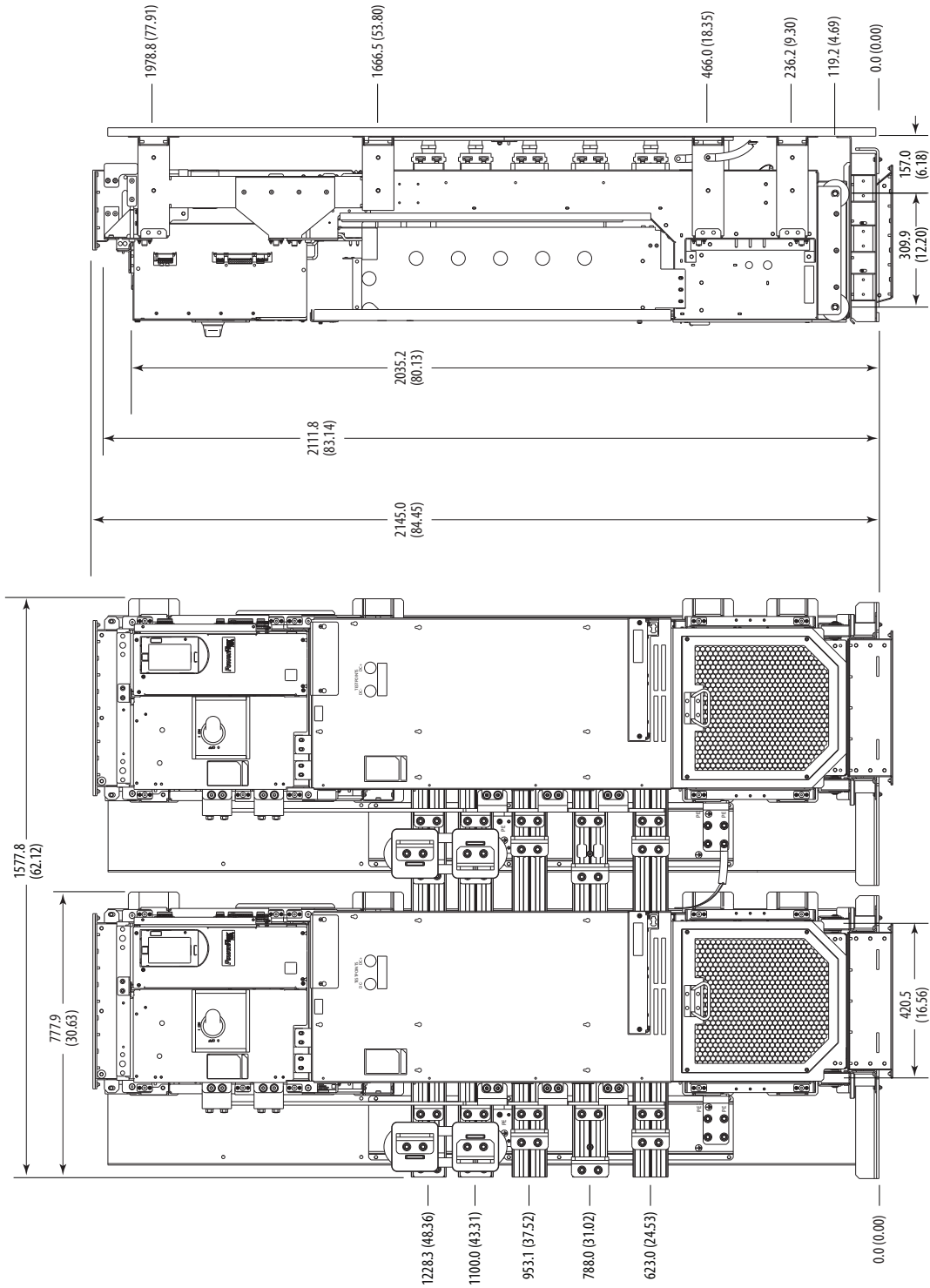

Frame Type **Approximate Dimensions - mm (in.)**

10

MCC Style Cabinet, 600 mm (23.6 in.) Deep IP20, NEMA/UL Type 1 Enclosure Code B

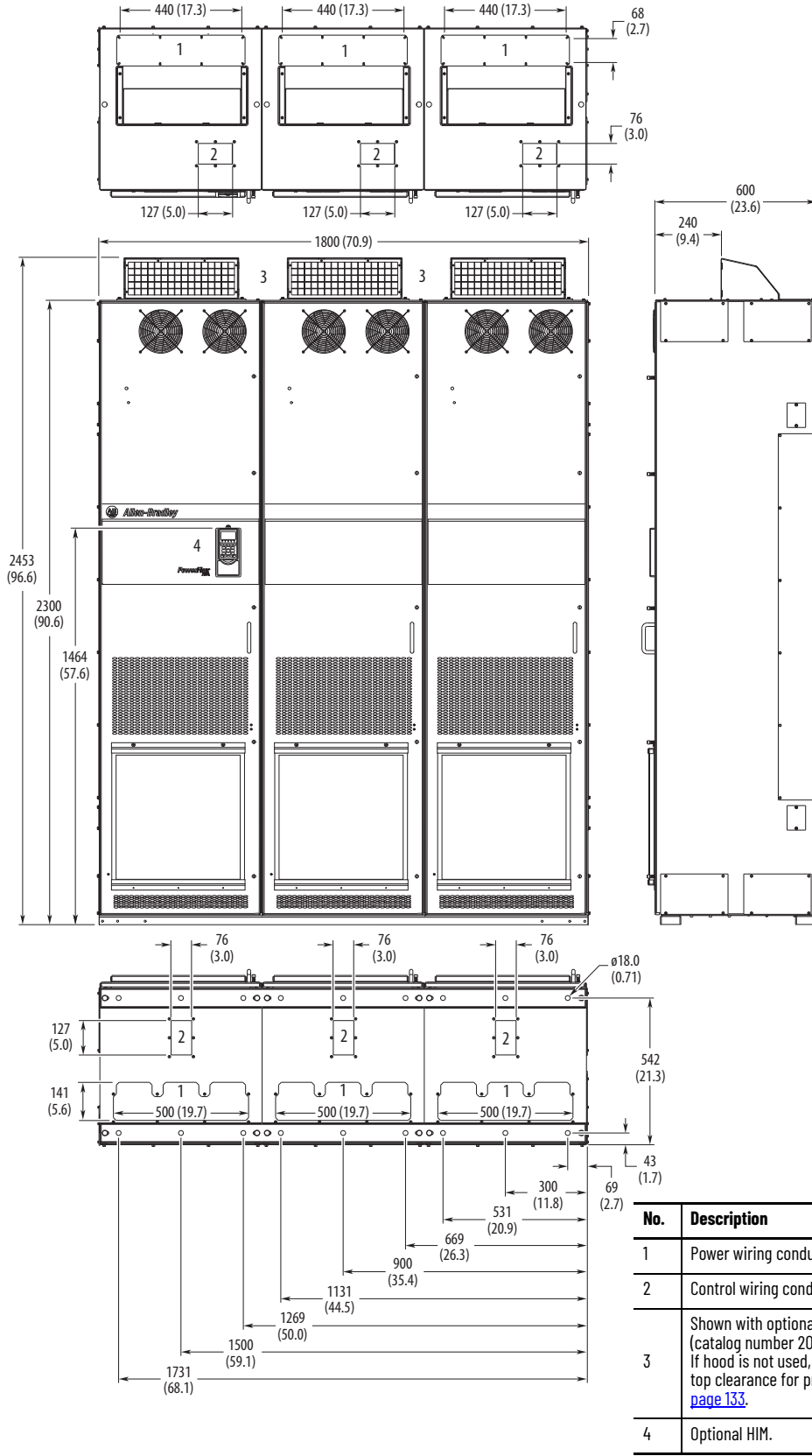

No.	Description
1	Power wiring conduit plates.
2	Control wiring conduit plates.
3	Shown with optional hood (catalog number 20-750-H00D1-F8). If hood is not used, allow sufficient top clearance for proper airflow. See page 133 .
4	Optional HIM.

Frame Type **Approximate Dimensions - mm (in.)**

10

MCC Style Cabinet, 800 mm (31.5 in.) Deep
 IP20, NEMA/UL Type 1 Enclosure Code L (AC Input)
 Enclosure Codes P, W (DC Input)

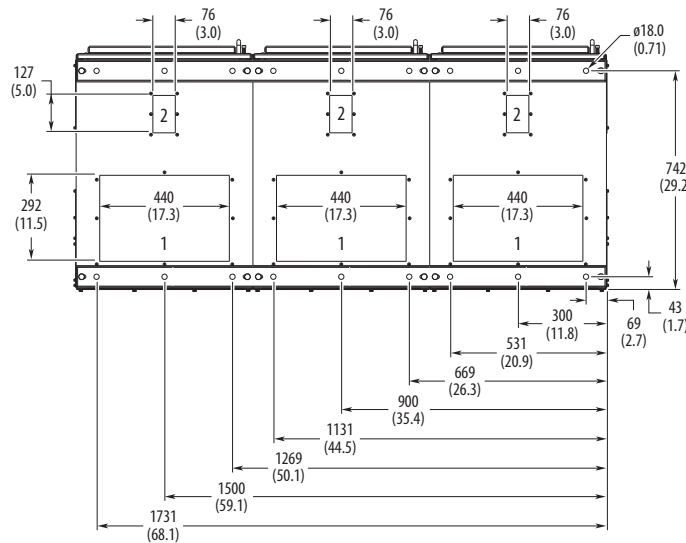
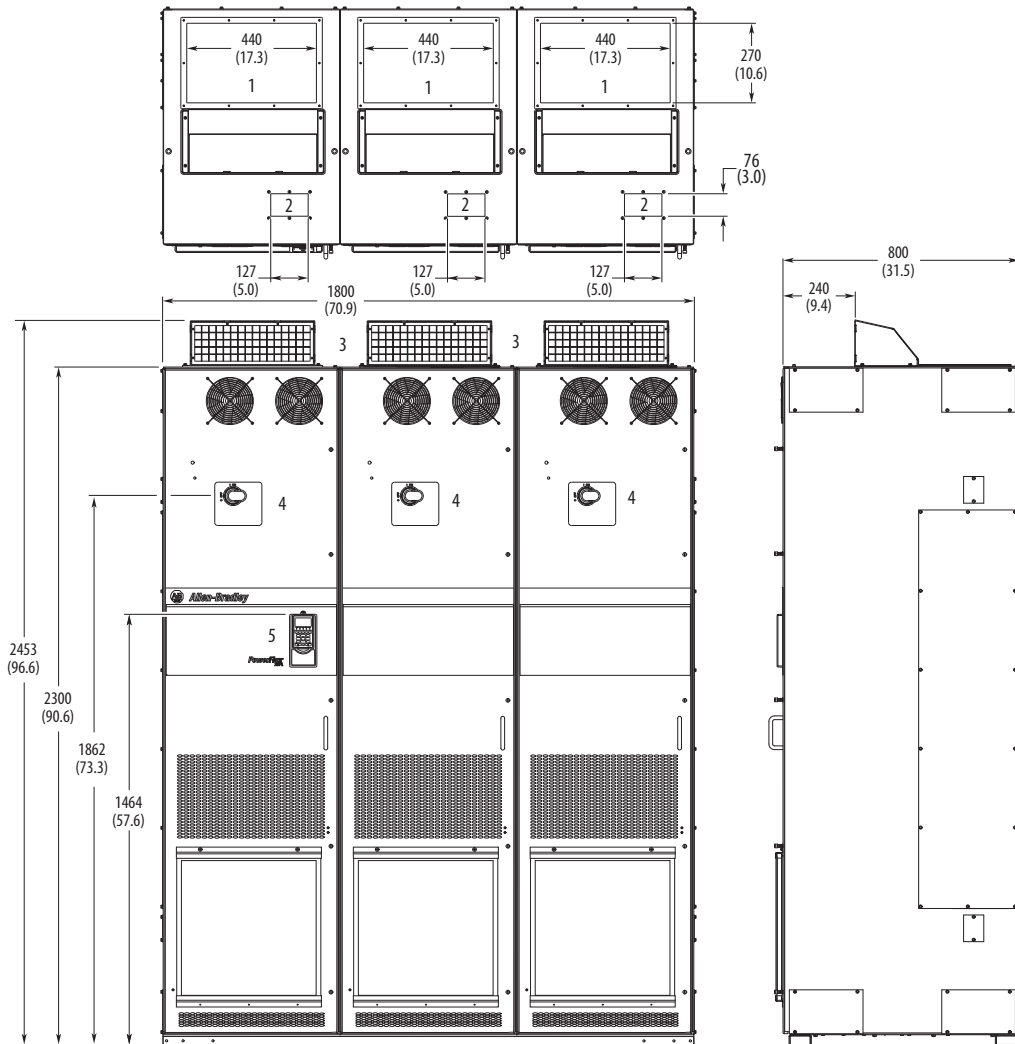

No.	Description
1	Power wiring conduit plates.
2	Control wiring conduit plates.
3	Shown with optional hood (catalog number 20-750-HOOD1-F8). If hood is not used, allow sufficient top clearance for proper airflow. See page 133 .
4	Disconnect switches - Common DC Input drives.
5	Optional HIM.

Frame Type **Approximate Dimensions - mm (in.)**

10

MCC Style Cabinet
 800 mm (31.5 in.) Deep
 IP54, NEMA 12 Enclosure
 Codes K, Y (DC Input)
 IP54, UL Type 12 Enclosure Code J
 (AC Input)

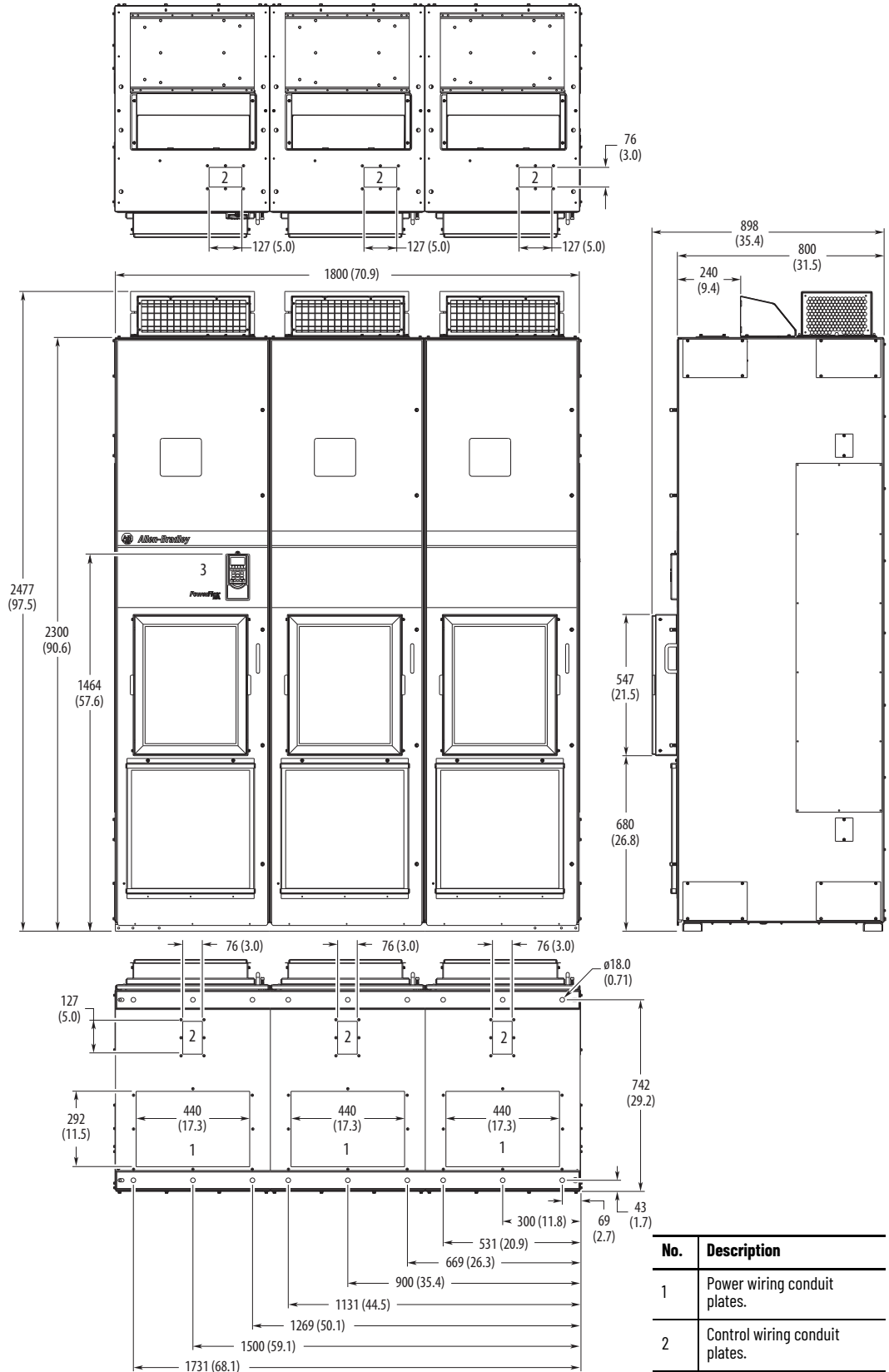

Frame Type Approximate Dimensions - mm (in.)

10

Open Style
IPOD, NEMA/UL
Open Type
Enclosure Code
T
(AC Input)

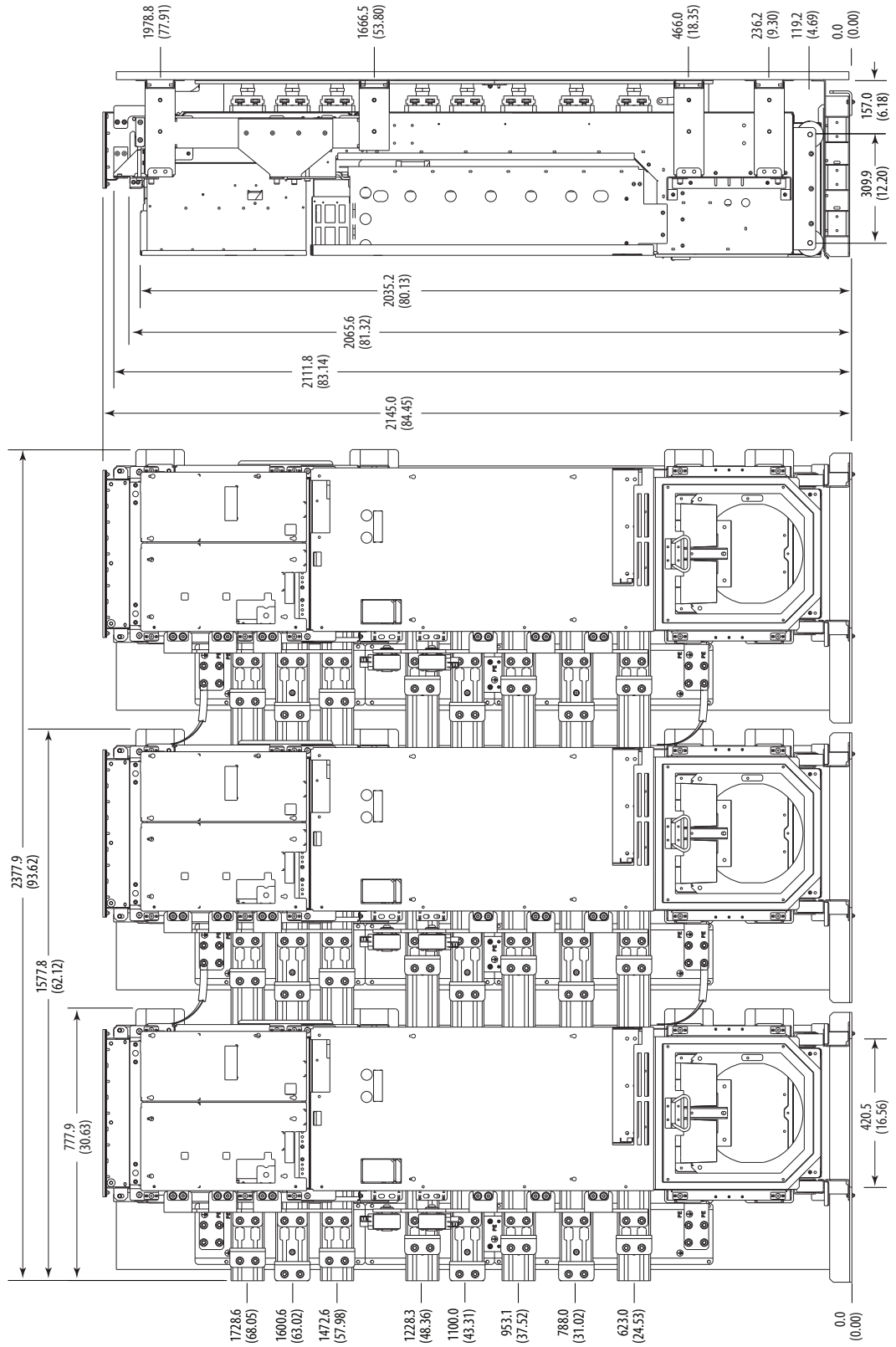

Frame Type Approximate Dimensions - mm (in.)

10

Open Style
 IPOO, NEMA/UL
 Open Type
 Enclosure Code
 T
 (DC Input)

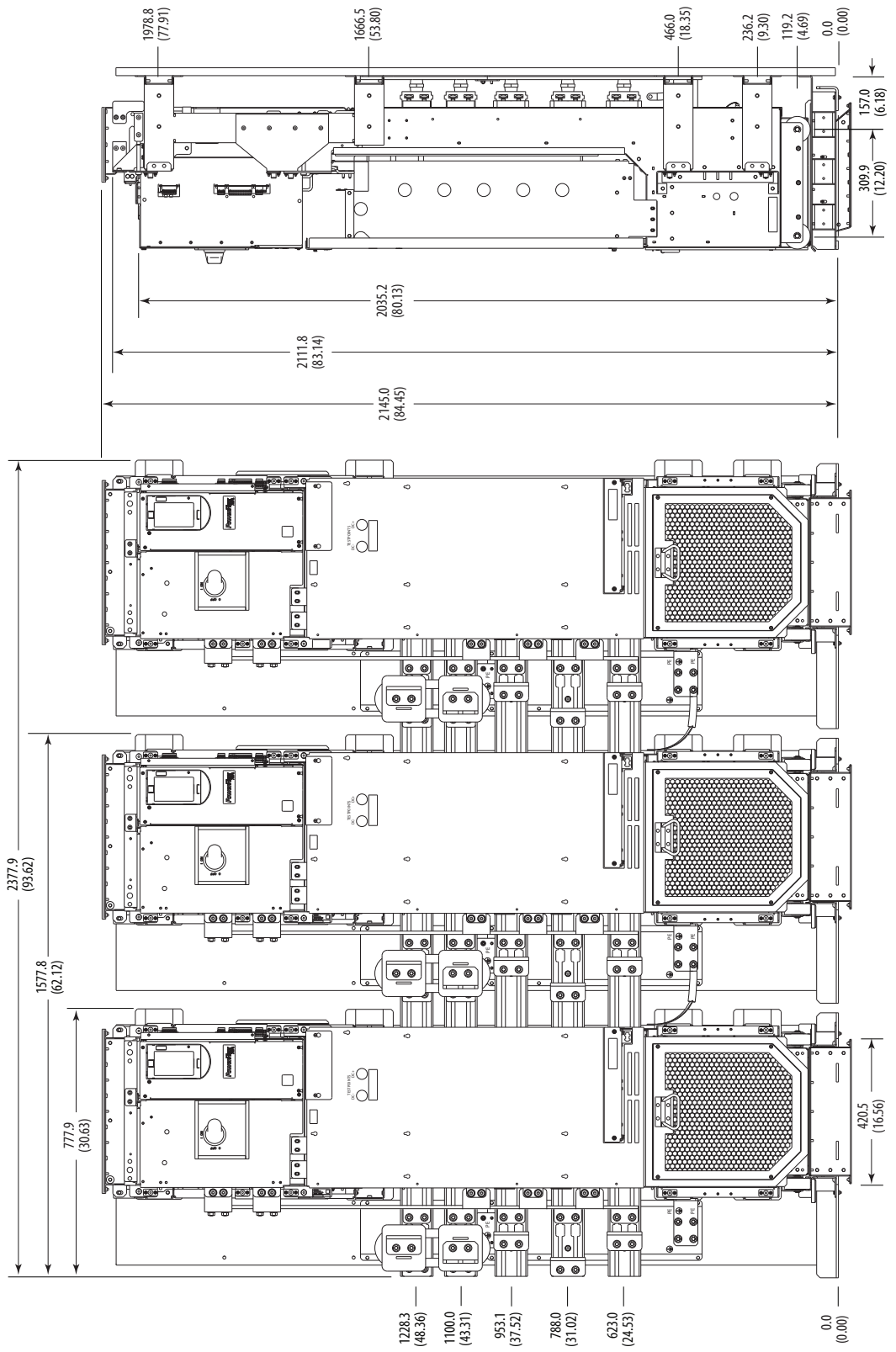

Frame Type Approximate Dimensions - mm (in.)

1..5 NEMA/UL Type 1 Kit

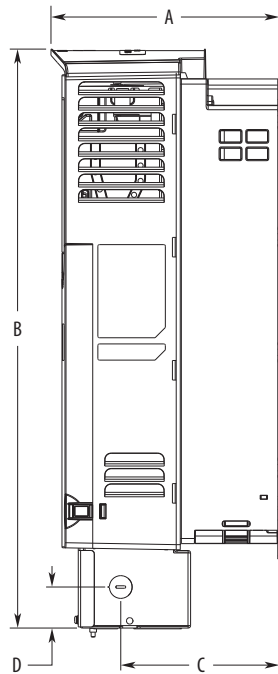

Frame 4 Shown

Frame	A	B	C	D
1	215.4 (8.48)	458.8 (18.06)	-	-
2	222.2 (8.75)	497.1 (19.57)	117.7 (4.63)	38.0 (1.50)
3	223.1 (8.78)	530.1 (20.87)	154.7 (6.09)	38.0 (1.50)
4	222.7 (8.77)	564.4 (22.22)	154.7 (6.09)	40.0 (1.57)
5	222.7 (8.77)	665.4 (26.20)	155.0 (6.10)	55.0 (2.17)

IMPORTANT

NEMA Type 1 Kits (20-750-NEMA-Fx) do not change the mounting dimensions.

6 NEMA/UL Type 1 Kit

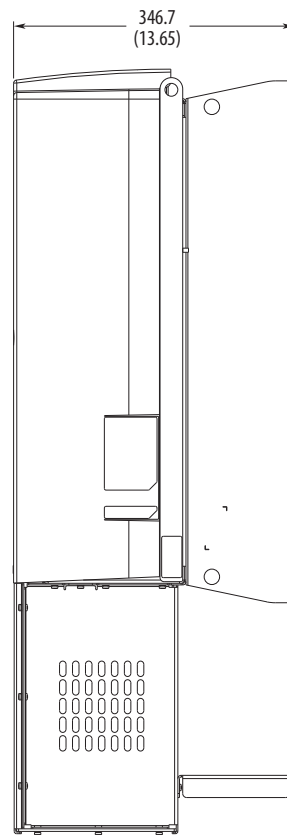
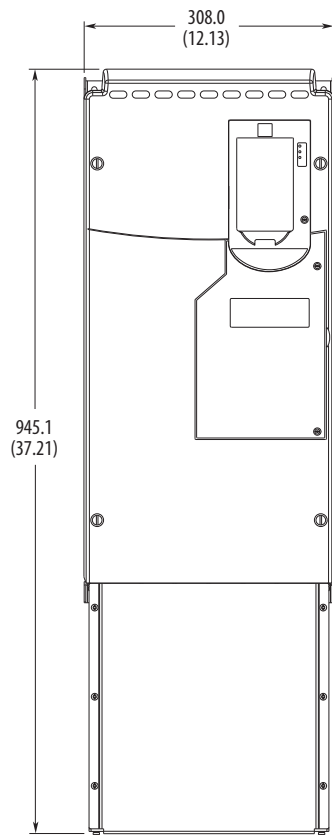

Frame Type Approximate Dimensions - mm (in.)

1...5 NEMA/UL Type 1 Bottom View

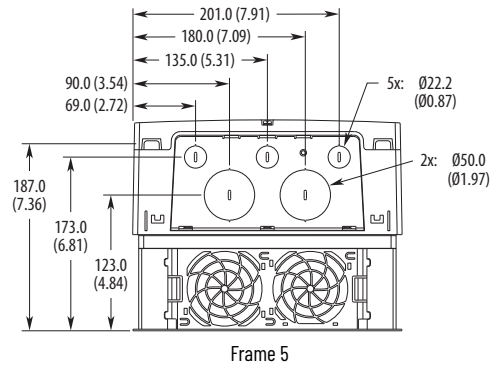
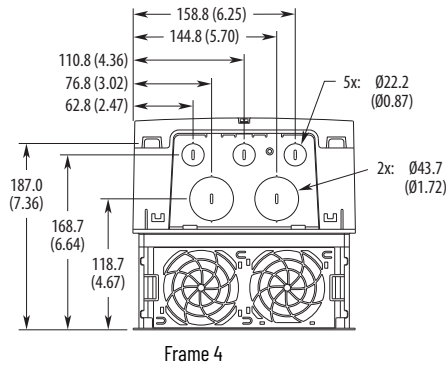
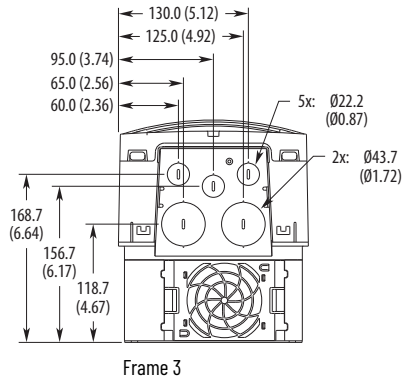
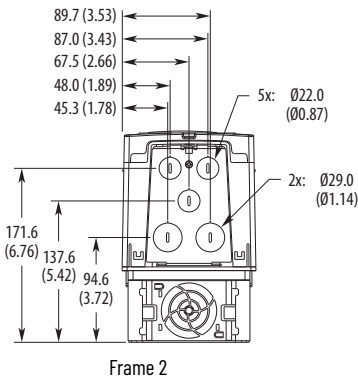
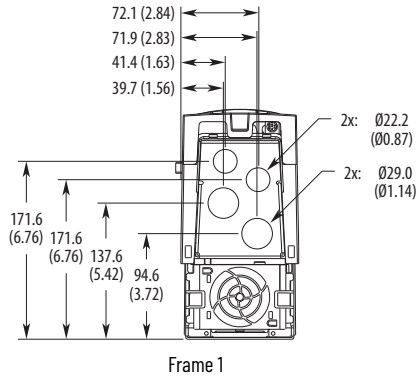

Frame Type Approximate Dimensions - mm (in.)

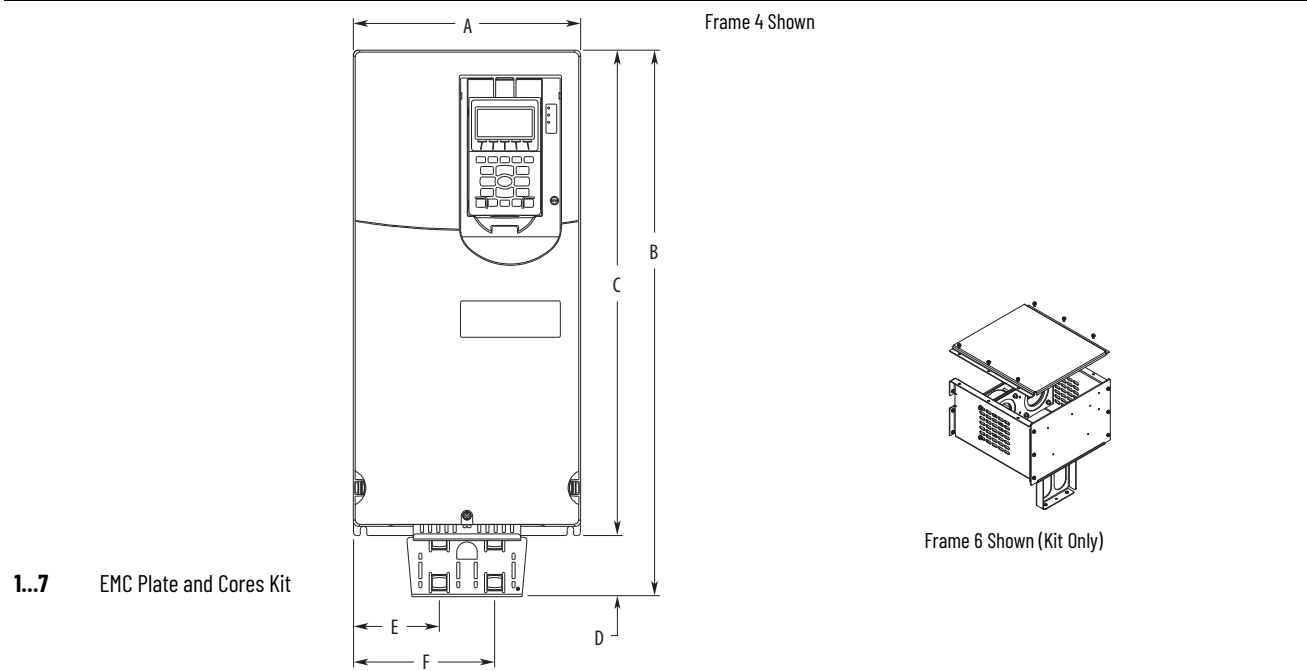

Enclosures are shown without venting. Supplied enclosures have proper venting.

Frame	A	B	C	D	E	F
1	110.0 (4.33)	478.8 (18.85)	400.5 (15.77)	78.3 (3.08)	37.4 (1.47)	73.4 (2.89)
2	134.5 (5.30)	485.9 (19.13)	424.2 (16.70)	61.7 (2.43)	43.5 (1.71)	79.5 (3.13)
3	190.0 (7.48)	514.0 (20.24)	454.0 (17.87)	60.0 (2.36)	74.0 (2.91)	116.0 (4.57)
4	222.0 (8.74)	533.7 (21.01)	474.0 (18.66)	59.7 (2.35)	84.0 (3.31)	138.0 (5.43)
5	270.0 (10.63)	609.7 (24.00)	550.0 (21.65)	59.7 (2.35)	77.8 (3.06)	191.8 (7.55)

IMPORTANT EMC Kits (20-750-EMCx-Fx) do not change the mounting dimensions. See the PowerFlex 750-Series EMC Plate and Cores Installation Instructions, publication [750-IN006](#), for detailed information on kit installation.

Frame	Type	Approximate Dimensions - mm (in.)
-------	------	-----------------------------------

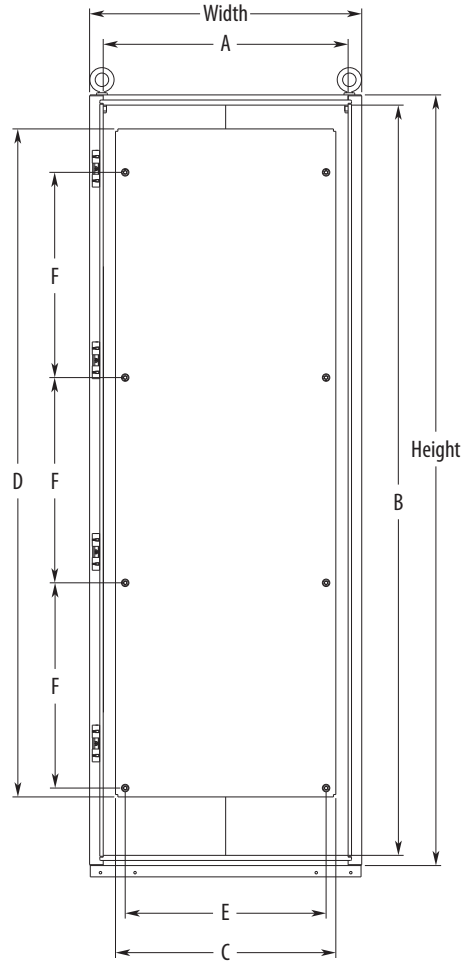

- Power Option Cabinet
600 mm and 800 mm
Wide

Cat. No.	Height	Width	Depth	A	B	C	D	E	F
20-750-PBAY-66	2265.5 (89.2)	600 (23.6)	600 (23.6)	520 (20.5)	2205.5 (86.8)	447.7 (17.6)	1963.7 (77.3)	390.5 (15.4)	603.3 (23.8)
20-750-PBAY-68	2265.5 (89.2)	600 (23.6)	800 (31.5)	520 (20.5)	2205.5 (86.8)	447.7 (17.6)	1963.7 (77.3)	390.5 (15.4)	603.3 (23.8)
20-750-PBAY-86	2265.5 (89.2)	800 (31.5)	600 (23.6)	720 (28.3)	2205.5 (86.8)	647.7 (25.5)	1963.7 (77.3)	590.5 (23.2)	603.3 (23.8)
20-750-PBAY-88	2265.5 (89.2)	800 (31.5)	800 (31.5)	720 (28.3)	2205.5 (86.8)	647.7 (25.5)	1963.7 (77.3)	590.5 (23.2)	603.3 (23.8)

See the PowerFlex 750-Series Power Option Cabinets Installation Instructions, publication [750-IN030](#), for details.

Frame	Type	Approximate Dimensions - mm (in.)
-------	------	-----------------------------------

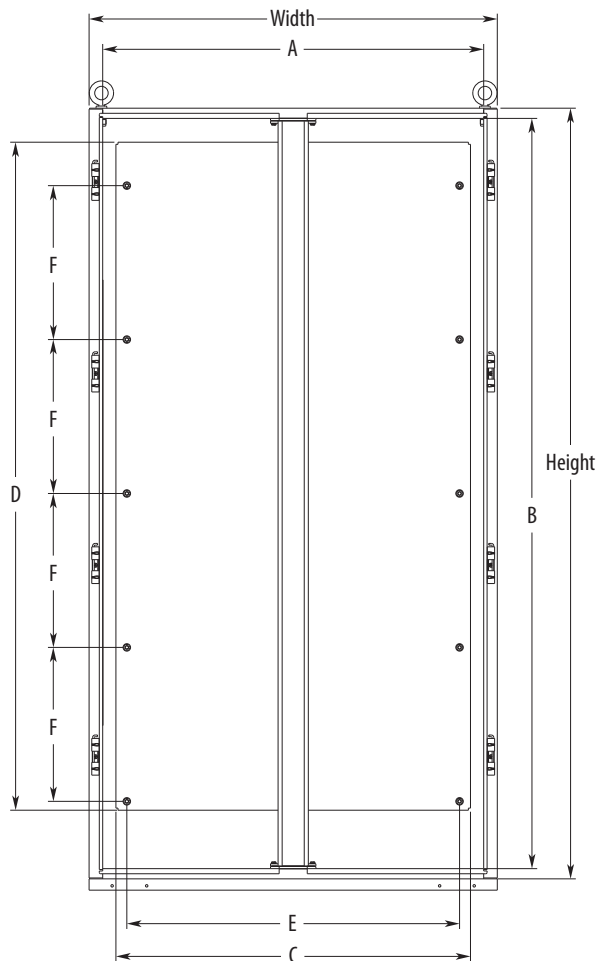

Power Option Cabinet
1200 mm Wide

Cat. No.	Height	Width	Depth	A	B	C	D	E	F
20-750-PBAY-126	2265.5 (89.2)	1200 (47.2)	600 (23.6)	1120 (44.1)	2205.5 (86.8)	1042.3 (41.0)	1963.7 (77.3)	978.1 (38.5)	452.5 (17.8)
20-750-PBAY-128	2265.5 (89.2)	1200 (47.2)	800 (31.5)	1120 (44.1)	2205.5 (86.8)	1042.3 (41.0)	1963.7 (77.3)	978.1 (38.5)	452.5 (17.8)

See the PowerFlex 750-Series Power Option Cabinets Installation Instructions, publication [750-IN030](#), for details.

Drive Options

This section provides information for the drive options.

Human Interface Modules

This section provides information for the human interface modules.

Cat. No.	Description
20-HIM-A0	No HIM (blank plate)
20-HIM-A6	Enhanced, LCD, full numeric, handheld/local, NEMA Type 1
20-HIM-C6S	Enhanced, LCD, full numeric, IP66 NEMA Type 4X/12 (for indoor use only) ⁽¹⁾



Blank Plate

20-HIM-A6

20-HIM-C6S

(1) Includes a 3 m (9.8 ft) catalog number 1202-C30 interface cable for connection to drive.

IMPORTANT The 20-HIM-A6 and the 20-HIM-C6S are a product of category C2 according to IEC 61800-3. In a domestic environment, this product can cause radio interference in which case supplementary mitigation measures can be required.

Human Interface Modules Specifications

Attribute	20-HIM-A6	20-HIM-C6S
Drive Protocol Data rates	Drive Peripheral Interface (DPI™) 125 Kbps or 500 Kbps	
Consumption Drive (DPI)	140 mA at 12V DC supplied by the host drive	
Dimensions, H x W x D	20-HIM-A6: 116 x 70 x 16 mm (4.57 x 2.75 x 0.63 in.) 20-HIM-C6S: 180 x 93 x 25 mm (7.08 x 3.66 x 0.98 in.)	
Weight	91 g (3.2 oz)	173 g (5.7 oz)
Temperature Operating Storage	0...50 °C (32...122 °F) -40...+85 °C (-40...+185 °F)	
Relative humidity	5...95% noncondensing	
Atmosphere	<p>IMPORTANT Do not install the module in an area where the ambient atmosphere contains volatile or corrosive gas, vapors, or dust. If the module is not going to be installed right away, store the module in an area where it is not exposed to a corrosive atmosphere.</p>	
UV radiation	The HIM is not UV rated.	
Vibration Operating Nonoperating	2.5 G at 5...2000 Hz 5 G at 5...2000 Hz	
Shock Operating Nonoperating	30 G peak acceleration, 11 (±1) ms pulse width 50 G peak acceleration, 11 (±1) ms pulse width	
Certifications	See Certifications and Specifications on page 60 for current certification information.	

Human Interface Module Accessories

Cat. No.	Description
20-HIM-B1	Bezel kit for LCD HIMs, NEMA Type 1 ⁽¹⁾
20-HIM-H10	PowerFlex HIM interface cable, 1 m (39 in.) ⁽²⁾
1202-C03 1202-C10 1202-C30 1202-C90	Comm option cable kit (male-male) 0.33 m (1.1 ft) 1 m (3.3 ft) 3 m (9.8 ft) 9 m (29.5 ft)
1202-H03 1202-H10 1202-H30 1202-H90	Cable kit (male-female) ⁽³⁾ 0.33 m (1.1 ft) 1 m (3.3 ft) 3 m (9.8 ft) 9 m (29.5 ft)

Human Interface Module Accessories (Continued)

Cat. No.	Description
1202-CBL-KIT-100M	DPI cable kit with connectors, tools, and 100 m (328 ft) cable
1202-TB-KIT-SET	DPI cable connector kit
1203-S03	DPI/SCANport™ one-to-two-port splitter cable

(1) Includes a 3 m (9.8 ft) catalog number 1202-C30 interface cable for connection to drive.

(2) Required only when HIM is used as hand-held or remote.

(3) Required with catalog number 20-HIM-H10 for distances up to a total maximum of 10 m (32.8 ft).

Communication Option Kits and Accessories

This section provides information for communication option kits and accessories.

Communication Option Kits and Accessories

Cat. No.	Description (see page 193 for specifications)
20-750-BNETIP	BACnet/IP option module
20-750-CNETC	Coaxial ControlNet™ option module
20-COMM-C ⁽¹⁾	ControlNet communication adapter (coax)
20-750-DNET	DeviceNet™ option module
20-COMM-D ⁽¹⁾	DeviceNet communication adapter
20-750-ENETR	Dual-port EtherNet/IP™ option module
20-750-ENET2P	Dual-port EtherNet/IP option module
20-COMM-E ⁽¹⁾	EtherNet/IP communication adapter
20-COMM-H ⁽¹⁾	HVAC communication adapter (only Modbus RTU can be used)
20-COMM-K ⁽¹⁾	CANopen communication adapter
20-COMM-L ⁽¹⁾⁽²⁾	LonWorks communication adapter
20-COMM-M ⁽¹⁾	Modbus/TCP communication adapter
20-750-PBUS	PROFIBUS DPV1 option module
20-750-PNET	Single-port Profinet I/O option module
20-750-PNET2P	Dual-port Profinet I/O option module
20-COMM-P ⁽¹⁾	PROFIBUS DP communication adapter
20-COMM-Q ⁽¹⁾	ControlNet communication adapter (fiber)
20-COMM-S ⁽¹⁾	RS-485 DF1 communication adapter
20-XCOMM-AC-PS1	External communication kit power supply
20-XCOMM-DC-BASE	DPI external communication kit ⁽³⁾
20-XCOMM-IO-OPT1	External DPI I/O option board ⁽⁴⁾
1769-SM1 ⁽²⁾	Compact I/O™ module (3-channel)
1203-SNM	Serial null modem adapter
1203-SSS	Smart Self-powered serial converter (RS-232) includes 1203-SFC and 1202-C10 cables
1203-USB	Universal serial bus (USB) converter includes 2 m (6.6 ft) USB, 20-HIM-H10, and 22-HIM-H10 cables
1786-TPS	ControlNet T-tap straight
20-750-20COMM-F1	Communication carrier card for PowerFlex 750-Series Frame 1 drives
20-750-20COMM	Communication carrier card for PowerFlex 750-Series Frame 2 or higher drives

(1) Requires a communication carrier card (catalog number 20-750-20COMM or 20-750-COMM-F1). See [page 192](#) for compatibility details.

(2) This product is [discontinued](#).

(3) Only compatible with the following communication options: catalog number 20-COMM-E EtherNet/IP; 20-COMM-C ControlNet (coax); 20-COMM-Q ControlNet (fiber); 20-COMM-D DeviceNet (Series B or later); and 20-COMM-M Modbus/TCP.

(4) For use only with DPI external communications kit, catalog number 20-XCOMM-DC-BASE.

PowerFlex 755 System Resource Allocation

Some drive configurations that use certain communication options can exceed the available resources of the processor on the main control board. This issue is a consideration for PowerFlex 755 drives with firmware revision 2.000 (or later). See the PowerFlex 750-Series Programming Manual, publication [750-PM001](#), for details.

PowerFlex 750-Series Legacy Communication Options

Most legacy communication adapters (20-COMM) can be used with the PowerFlex 755 drives (with these restrictions):

- **Frame 1** - We recommend that you install catalog number 20-750-20COMM-F1 communication carrier card in port 4. Port 5 is not accessible when this module is installed.
- **Frames 2 and larger** - We recommend that you install catalog number 20-750-20COMM communication carrier card in port 6. If you use port 4 or 5, the adjacent left port is inaccessible to other option modules and can interfere with network cable connections. For details, contact Rockwell Automation technical support.

Adapter		Accesses Ports 0...6 for I/O Connections (implicit and Explicit Messaging)	Accesses Ports 7 and Higher (I/O, Explicit Messaging)	Supports Drive Add-on Profiles	Supports Asian Languages ⁽¹⁾
Cat. No.	Type				
20-COMM-B	BACnet MS/TP	Not compatible			
20-COMM-C	ControlNet (Coax)	Revision 3.001 ⁽²⁾	Revision 3.001 ⁽²⁾	See footnote ⁽³⁾	Revision 3.001 ⁽²⁾
20-COMM-D	DeviceNet	See footnote ⁽⁴⁾	Not compatible		
20-COMM-E	EtherNet/IP	Revision 4.001 ⁽²⁾	Revision 4.001 ⁽²⁾	See footnote ⁽³⁾	Revision 4.001 ⁽²⁾
20-COMM-H	RS-485 HVAC	Revision 2.009 ⁽⁵⁾⁽²⁾	Not compatible		
20-COMM-K	CANopen	Revision 1.001 ⁽²⁾			
20-COMM-L ⁽⁶⁾	LonWorks	Revision 1.007 ⁽²⁾			
20-COMM-M	Modbus/TCP	Revision 2.001 ⁽²⁾	Revision 2.001 ⁽²⁾	Not compatible	Revision 2.001 ⁽²⁾
20-COMM-P	PROFIBUS DP	Revision 1.006 ⁽²⁾	Revision 1.006 ⁽²⁾		Not compatible
20-COMM-Q	ControlNet (Fiber)	Revision 3.001 ⁽²⁾	Revision 3.001 ⁽²⁾	See footnote ⁽³⁾	Revision 3.001 ⁽²⁾
20-COMM-S	RS-485 DF1	See footnote	Not compatible		

(1) Chinese, Japanese, and Korean languages are supported at the time of publication.
 (2) Requires this adapter firmware revision or higher.
 (3) Requires firmware revision 1.05 or later of the drive Add-on Profiles for Studio 5000 Logix Designer application.
 (4) Controller must be able to read/write 32-bit floating point (REAL) values.
 (5) Supports all three modes of operation (RTU, P1, and N2).
 (6) This product is [discontinued](#).

Environmental Specifications – Communication Modules

Attribute	Description
Temperature Operating Storage	-10...+50 °C (14...122 °F) -40...+85 °C (-40...+185 °F)
Relative humidity	5...95% noncondensing
Atmosphere	IMPORTANT: Do not install the module in an area where the ambient atmosphere contains volatile or corrosive gas, vapors, or dust. If the module is not going to be installed right away, store the module in an area where it is not exposed to a corrosive atmosphere.

Communication Options and Accessories Specifications

Attribute	20-750-BNETIP	20-750-CNETC	20-COMM-C	20-750-DNET	20-COMM-D	20-750-ENETR	20-750-ENET2P
Network Protocol Data rate	BACnet/IP 10/100 Mbps	ControlNet 5 Mbps (fixed)	ControlNet 5 Mbps	DeviceNet 125 Kbps, 250 Kbps, and 500 Kbps	DeviceNet 125 Kbps, 250 Kbps, and 500 Kbps	EtherNet/IP 10/100 Mbps, Half/ Full Duplex	EtherNet/IP 10/100 Mbps, Half/ Full Duplex
Drive Protocol Data rates	DPI 500 Kbps	DPI 500 Kbps	DPI 125 Kbps or 500 Kbps	DPI 500 Kbps	DPI 125 Kbps or 500 Kbps	DPI 500 Kbps	DPI 500 Kbps
Consumption Drive (DPI) Network	250 mA at 14V DC None	250 mA at 14V DC None	275 mA at 5V DC None	50 mA at 14V DC 60 mA at 24V DC	150 mA at 5V DC 60 mA at 24V DC	250 mA at 14V DC None	250 mA at 14V DC None
Dimensions H x L x W mm (in)	16.0 x 130.0 x 83.0 (0.63 x 5.12 x 3.27)	68.0 x 150.0 x 26.0 (2.70 x 5.90 x 1.00)	16.0 x 103.0 x 80.0 (0.63 x 4.00 x 3.13)	68.0 x 150.0 x 26.0 (2.70 x 5.90 x 1.00)	19.0 x 86.0 x 78.5 (0.75 x 3.39 x 3.09)	68.0 x 150.0 x 26.0 (2.70 x 5.90x 1.00)	68.0 x 150.0 x 26.0 (2.70 x 5.90x 1.00)
Weight g (oz)	60 (2.0)	62 (2.1)	85 (3.0)	62 (2.1)	85 (3.0)	62 (2.1)	62 (2.1)
Compliance UL cUL CE, UKCA RCM	UL508C CAN/CSA C22.2 No. 14 EN61800-3 EN61800-3	UL508C CAN/CSA C22.2 No. 14 EN61800-3 EN61800-3	UL508C CAN/CSA C22.2 No. 14 EN61800-5-1, EN61800-3 EN61800-3	UL508C CAN/CSA C22.2 No. 14 EN61800-3 EN61800-3	UL508C CAN/CSA C22.2 No. 14 EN61800-5-1, EN61800-3 EN61800-3	UL508C CAN/CSA C22.2 No. 14 EN61800-3 EN61800-3	UL61800-5-1

Communication Options and Accessories Specifications (continued)

Attribute	20-COMM-E	20-COMM-H	20-COMM-K	20-COMM-L ⁽¹⁾	20-COMM-M	20-750-PBUS	20-750-PNET 20-750-PNET2P
Network Protocol Data rate	EtherNet/IP 10/100 Mbps, Half/ Full Duplex	Modbus RTU, Metasys N2, or Siemens P1 FLN RTU: 4800...38400 bps N2: 9600 bps P1: 4800 bps or 9600 bps	CANopen 10 Kbps...1 Mbps	LonWorks 78 Kbps	Modbus/TCP 10/100 Mbps, Half/Full Duplex	PROFIBUS 9600 bps...12 Mbps (autobauds)	Profinet 10/100 Mbps
Drive Protocol Data rates	DPI 125 Kbps or 500 Kbps	DPI 125 Kbps or 500 Kbps	DPI 125 Kbps or 500 Kbps	DPI 125 Kbps or 500 Kbps	DPI 125 Kbps or 500 Kbps	DPI 500 Kbps	DPI 500 Kbps
Consumption Drive (DPI) Network	370 mA at 5V DC —	150 mA at 5V DC —	500 mA at 5V DC None	200 mA on DPI —	350 mA at 5V DC —	250 mA at 14V DC None	250 mA at 14V DC None
Dimensions H x L x W mm (in)	19.0 x 86.0 x 78.5 (0.75 x 3.39 x 3.09)	19.0 x 86.0 x 78.5 (0.75 x 3.39 x 3.09)	19.0 x 86.0 x 78.5 (0.75 x 3.39 x 3.09)	20.0 x 86.0 x 78.5 (0.79 x 3.39 x 3.09)	19.0 x 86.0 x 78.5 (0.75 x 3.39 x 3.09)	16.0 x 130.0 x 83.0 (0.63 x 5.12 x 3.27)	16.0 x 130.0 x 83.0 (0.63 x 5.12 x 3.27)
Weight g (oz)	85 (3.0)	85 (3.0)	85 (3.0)	85 (3.0)	85 (3.0)	57 (2.0)	60 (2.0)
Compliance UL cUL CE, UKCA RCM	UL508C CAN/CSA C22.2 No. 14 EN61800-5-1, EN61800-3 EN61800-3	UL508C CAN/CSA C22.2 No. 14 EN61800-5-1, EN61800-3 EN61800-3	UL508C CAN/CSA C22.2 No. 14 — —	UL508C — — —	UL508C CAN/CSA C22.2 No. 14 EN61800-5-1, EN61800-3 EN61800-3	UL508C CAN/CSA C22.2 No.14 IEC61800-3 EN61800-3	UL508C CAN/CSA C22.2 No. 14 EN61800-3 EN61800-3

(1) This product is [discontinued](#).

Communication Options and Accessories Specifications (continued)

Attribute	20-COMM-P	20-COMM-Q	20-COMM-S	1203-SSS	1203-USB	1769-SM1 ⁽¹⁾
Network Protocol Data rate	PROFIBUS 10 Kbps...12 Mbps	ControlNet 5 Mbps	DF1 1200...38400 bps	DF1 9600...38400 bps	Universal Serial Bus (USB) 115.2 Kbps	-
Drive Protocol Data rates	DPI 125 Kbps or 500 Kbps	DPI 125 Kbps or 500 Kbps	DPI 125 Kbps or 500 Kbps	DPI or SCANport™ 125 Kbps or 500 Kbps (only DPI)	SCANport, DPI, or DSI 125, 125/500, 19.2 Kbps	DPI or SCANport 125 Kbps or 500 Kbps (only DPI)
Consumption Drive (DPI) Network	370 mA at 5V DC -	275 mA at 5V DC -	150 mA at 5V DC -	130 mA at 12V DC -	130 mA at 12V DC 170 mA at +5V DC (DSI)	Module: 280 mA at 5V DC Channel: 60 mA at 12V DC
Dimensions H x L x W mm (in)	19.0 x 86.0 x 78.5 (0.75 x 3.39 x 3.09)	16.0 x 103.0 x 80.0 (0.63 x 4.00 x 3.13)	16.0 x 86.0 x 81.0 (0.63 x 3.34 x 3.16)	103.5 x 73.4 x 23.6 (4.08 x 2.89 x 0.93)	103.5 x 73.4 x 23.6 (4.08 x 2.89 x 0.93)	103.5 x 73.4 x 23.6 (4.08 x 2.89 x 0.93)
Weight g (oz)	57 (2.0)	85 (3.0)	60 (2.0)	71 (2.5)	71 (2.5)	71 (2.5)
Compliance UL cUL CE, UKCA RCM	UL508C CAN/CSA C22.2 No. 14 - - -	UL508C CAN/CSA C22.2 No. 14 EN61800-5-1, EN61800-3 EN61800-3	UL508C CAN/CSA C22.2 No. 14 EN61800-3 EN61800-3	UL508C CAN/CSA C22.2 No. 14 EN61800-5-1, EN61800-3 EN61800-3	UL508C CAN/CSA C22.2 No. 14 - - -	UL508C CAN/CSA C22.2 No. 14 - - -

(1) This product is [discontinued](#).

Communication Options and Accessories Specifications (continued)

Attribute	20-XCOMM-DC-BASE	20-XCOMM-IO-OPT1	20-XCOMM-AC-PS1
Network Protocol Data rate	Dependent on installed adapter Dependent on installed adapter	-	-
Drive Protocol Data rates	DPI 125/500 Kbps	-	-
Number of inputs	-	6 (single common)	-
Input voltage type	-	24V DC source load	-
Maximum input voltage	-	27V DC	-
Rated input voltage	-	-	100...240V AC
Operating input voltage	-	-	90...264V AC
AC input frequency	-	-	47...63 Hz
Maximum input current	-	8 mA (each input)	-
Guaranteed ON-state voltage	-	10...27V DC (3 mA minimum)	-
Guaranteed OFF-state voltage	-	0...5V DC (2 mA maximum)	-
Reverse polarity protected	-	-30V DC	-
Input response time	-	25 ms + network update time ⁽²⁾	-
Number of outputs	-	Two relay outputs (individually isolated) • One form C contact • One form A (NO) contact	-
Maximum output contact voltage	-	27V DC/125V AC	-
Maximum output contact current	-	2 A	-
Output voltage	-	-	24V DC
Output current	-	-	830 mA

Communication Options and Accessories Specifications (continued)

Attribute	20-XCOMM-DC-BASE	20-XCOMM-IO-OPT1	20-XCOMM-AC-PS1
Expected contact life	-	1,000,000 cycles resistive at < 0.5 A 500,000 cycles inductive at < 0.5 A 500,000 cycles resistive at 1 A 300,000 cycles inductive at 1 A 300,000 cycles resistive at 2 A 150,000 cycles inductive at 2 A	-
Output response time	-	25 ms + network update time ⁽³⁾	-
Consumption Module	60 mA at 12V DC supplied from drive via DPI cable	-	-
Network	Ethernet: None ControlNet: None DeviceNet: 60 mA at 24V DC	-	-
DC power supply requirement	20-COMM-C: 105 mA at 24V DC ⁽¹⁾ 20-COMM-D: 60 mA at 24V DC ⁽¹⁾ 20-COMM-E: 140 mA at 24V DC ⁽¹⁾ 20-COMM-Q: 135 mA at 24V DC ⁽¹⁾ 20-COMM-M: 140 mA at 24V DC ⁽¹⁾	-	-
Dimensions (H x W x D)	108 x 108 x 75 (4.25 x 4.25 x 2.95) With I/O terminal block attached	-	-
Weight	340 g (12.0 oz)	-	-
Certifications	UL508C cUL CE, UKCA RCM	-	-

(1) The communication kit is powered by a nominal 24V DC. The current consumption that is listed in this table differs from the value that is shown on the label of the communication adapter. The label of the communication adapter is based on the adapter being powered by 5V DC from the drive.

(2) The I/O board is not designed for fast I/O response times. Do not use with input devices that transition (OFF-ON-OFF) faster than the response time. Potential inputs include auxiliary contact inputs from relays or overload, push buttons, and so on.

(3) The I/O board is not designed for fast I/O response times. Do not use with output devices that must transition (OFF-ON-OFF) faster than the response time. Potential output devices include pilot lights or a contact closure reset to another hardware device.

Feedback Options

This section provides information for the feedback options.

Cat. No.	Description
20-750-ENC-1 ⁽¹⁾ 20-750-ENC-1-XT	Incremental encoder
20-750-DENC-1 ⁽¹⁾ 20-750-DENC-1-XT	Dual incremental encoder
20-750-UFB-1 ⁽²⁾ 20-750-UFB-1-XT	Universal feedback board (includes Stegmann, Heidenhain, SSI, Biss, 5V incremental)

(1) Homing and registration functions are not supported when using this device with Studio 5000 Logix Designer[®] embedded motion instructions. To use the homing and registration functions, you must use the Universal Feedback Board (catalog number 20-750-UFB-1).

(2) Only PowerFlex 755 drives.

This table specifies which encoder type combinations work on a universal feedback board (UFB).

Encoder Combinations Compatible with Universal Feedback Board

		Encoder on Channel 0																			
		None	EnDat SC	Hiperface SC	BISS SC	SSI SC	EnDat FD ChX	EnDat FD ChY	BISS FD ChX	BISS FD ChY	SSI FD ChX	SSI FD ChY	SinCos only	Incmtl A B Z	Incmtl SC	LinTempo ChX	LinTempo ChY	LinStahl ChX	LinStahl ChY	Lin SSI ChX	Lin SSI ChY
Encoder on Channel 1	None	C	C	C	C	C	C	C	C	C	C	C	C	C	C	C	C	C	C	C	C
	EnDat SC	C	C	C	C	C	C	C	C	C	C	C	C	C	C	C	C	C	C	C	C
	Hiperface SC	C	C	C	C	C	C	C	C	C	C	C	C	C	C	C	C	C	C	C	C
	BISS SC	C	C	C	C	C	C	C	C	C	C	C	C	C	C	C	C	C	C	C	C
	SSI SC	C	C	C	C	C	C	C	C	C	C	C	C	C	C	C	C	C	C	C	C
	EnDat FD ChX	C	C	C	C	C	N	N	N	C	N	C	C	C	C	N	C	N	C	N	C
	EnDat FD ChY	C	C	C	C	C	N	N	C	N	C	N	C	C	C	C	N	C	N	C	N
	BISS FD ChX	C	C	C	C	C	N	C	N	N	N	C	C	C	C	N	C	N	C	N	C
	BISS FD ChY	C	C	C	C	C	C	N	N	N	C	N	C	C	C	C	N	C	N	C	N
	SSI FD ChX	C	C	C	C	C	N	C	N	N	N	C	C	C	C	N	C	N	C	N	C
	SSI FD ChY	C	C	C	C	C	C	N	C	C	N	N	C	C	C	C	N	C	N	C	N
	SinCos only	C	C	C	C	C	C	C	C	C	C	C	C	C	C	C	C	C	C	C	C
	Incmtl A B Z	C	C	C	C	C	C	C	C	C	C	C	C	N	C	C	C	C	C	C	C
	Incmtl SC	C	C	C	C	C	C	C	C	C	C	C	C	C	C	C	C	C	C	C	C
	LinTempo ChX	C	C	C	C	C	N	C	N	C	N	C	C	C	C	N	C	N	C	N	C
	LinTempo ChY	C	C	C	C	C	C	N	C	N	C	N	C	C	C	C	N	C	N	C	N
	LinStahl ChX	C	C	C	C	C	N	C	N	C	N	C	C	C	C	N	C	N	C	N	C
	LinStahl ChY	C	C	C	C	C	C	N	C	N	C	N	C	C	C	C	N	C	N	C	N
	Lin SSI ChX	C	C	C	C	C	N	C	N	C	N	C	C	C	C	N	C	N	C	N	C
	Lin SSI ChY	C	C	C	C	C	C	N	C	N	C	N	C	C	C	C	N	C	N	C	N

C	Compatible
N	Not compatible

I/O Option Kits

This section provides information for the I/O option kits.

Cat. No.	Description ⁽¹⁾
20-750-ATEX	ATEX option module with 1 thermosensor input connection (requires 11-Series I/O module)
20-750-1132C-2R	24V DC 11-Series I/O module with 1 analog in, 1 analog out, 3 digital in and 2 relay outputs
20-750-1133C-1R2T	24V DC 11-Series I/O module with 1 analog in, 1 analog out, 3 digital in, 1 relay and 2 transistor outputs
20-750-1132D-2R	115V AC 11-Series I/O module with 1 analog in, 1 analog out, 3 digital in and 2 relay outputs
20-750-2262C-2R	24V DC 22-Series I/O module with 2 analog in, 2 analog out, 6 digital in and 2 relay outputs
20-750-2262D-2R	115V AC 22-Series I/O module with 2 analog in, 2 analog out, 6 digital in and 2 relay outputs
20-750-2263C-1R2T	24V DC 22-Series I/O module with 2 analog in, 2 analog out, 6 digital in, 3 digital out, 1 relay, and 2 transistor outputs

(1) I/O option kits are not allowed in Integrated Motion on the EtherNet/IP Network mode.

Safety Options

Four safety options are available for the PowerFlex 750-Series drives:

- Safe Torque Off
- Safe Speed Monitor
- Integrated Safety - Safe Torque Off
- Integrated Safety Functions

Safe Torque Off is ideal for safety-related applications that require the removal of rotational power to the motor without shutting down the drive. Safe Torque Off functionality offers the benefit of quick start-up after a demand on the safety system. Safe Torque Off helps reduce wear from repetitive start-up, and provides safety ratings up to and including SIL CL3, PLe, and category 3.

Safe Speed Monitor is ideal for applications where the speed is controlled and monitored. The Safe Speed Monitor option combines Safe Torque Off capability with integrated safety relay functionality and the Safe Speed control technology in one hardware option. The Safe Speed Monitor option provides safety ratings up to and including SIL CL3, PLe, and category 4.

With the Safe Speed Monitor option, you can safely monitor and control the speed of your application, which allows operators to perform process or maintenance work without stopping the machine.

The Integrated Safety - Safe Torque Off (STO) option module provides either a hardwired or a networked STO function via an Ethernet/IP network.

With Networked Safe Torque Off, a GuardLogix safety controller issues the Safe Torque Off command over the Ethernet /IP network, and the PowerFlex drive executes the command.

Description	Cat. No.	Publication
Safe Torque Off ⁽¹⁾	20-750-S 20-750-S-XT	PowerFlex 750-Series Safe Torque Off Option Module User Manual, publication 750-UM002
Safe Speed Monitor ⁽¹⁾ ⁽²⁾ ⁽³⁾	20-750-S1	Safe Speed Monitor Option Module for PowerFlex 750-Series AC Drives Safety Reference Manual, publication 750-RM001
Integrated Safety - Safe Torque Off ⁽¹⁾	20-750-S3 20-750-S3-XT	PowerFlex 755/755T Integrated Safety - Safe Torque Off Option Module User Manual, publication 750-UM004
Integrated Safety Functions ⁽¹⁾	20-750-S4 20-750-S4-XT	PowerFlex 755/755T Integrated Safety Functions Option Module User Manual, publication 750-UM005

(1) Drive can accommodate only one option.

(2) Requires the dual incremental encoder or universal feedback option.

(3) Requires catalog number 20-750-EMCSSM1-F8 EMC Option Kit with Frame 8...9 drives.

IMPORTANT

You cannot install multiple safety option modules simultaneously. Only one of these safety option modules can be installed in the drive:

- PowerFlex 750-Series Safe Torque Off option module (catalog numbers 20-750-S, 20-750-S-XT)
- PowerFlex 750-Series Safe Speed Monitor option module (catalog numbers 20-750-S1)
- PowerFlex 755 Integrated Safety - Safe Torque Off option module (catalog numbers 20-750-S3, 20-750-S3-XT)
- PowerFlex 755 Integrated Safety Functions option module (catalog numbers 20-750-S4, 20-750-S4-XT)

The Integrated Safety Functions option module (20-750-S4) provides a networked STO (Safe Torque Off) function through an Ethernet/IP network. It is also equipped for Integrated (drive-based) Timed SS1, Monitored SS1, and Safe Brake Control, which operate in the drive and are activated through the network safety connection.

The Integrated Safety Functions option module also supports select controller-based IEC 61800-5-2 safety functions operating in GuardLogix 5580 or Compact GuardLogix 5380 controllers that use the Ethernet/IP network to communicate with the safety I/O. This support includes the new safety function instructions that are provided on the Drive Safety tab in the Logix Designer application.

Safe Torque Off and Safe Speed Monitor Specifications

Attribute	20-750-S Safe Torque Off	20-750-S1 Safe Speed Monitor
Standards	IEC/EN60204-1, ISO13489-1, IEC 61508, IEC 61800-5-2	IEC/EN60204-1, ISO12100, IEC 61508, IEC 61800-5-2
Safety category	Cat. 3 and PLe per EN ISO 13849-1; SIL CL3 per IEC 61508 and EN 62061	Cat. 4 and PLe per EN ISO 13849-1; SIL CL3 per IEC 61508 and EN 62061
Power supply (user I/O)	24V DC $\pm 10\%$, 0.8...1.1 x rated voltage ⁽³⁾ protected extra low voltage (PELV) or safety extra low voltage (SELV)	
Power consumption	4.4 W	36 W
Safety enable (SE+, SE-)	24V DC, 22 mA, short-circuit protected	-
Safety power (SP+, SP-)	24V DC, 35 mA, short-circuit protected	-
SLS outputs (68, 78)	-	24V DC, 50 mA, short-circuit protected
SS outputs (34, 44)	-	24V DC, 50 mA, short-circuit protected
Door control outputs (51, 52)	-	24V DC, short-circuit protected, 0.75 A bipolar (power to release/power to lock) configuration. 20 mA, cascading (2 CH Source) configuration.

Safe Torque Off and Safe Speed Monitor Specifications (Continued)

Attribute	20-750-S Safe Torque Off	20-750-S1 Safe Speed Monitor
Pulse outputs (S11, S21)	-	24V DC, 50 mA, short-circuit protected
Pulse inputs (S12, S22, S32, S42, S52, S62, S72, S82, X32, X42)	-	5 mA per input, max
Input ON voltage, min	24V DC $\pm 10\%$, 21.6...26.4V DC	15V
Input OFF voltage, max	5V	5V
Input OFF current, max	2.5 mA at 5V DC	2 mA
Input-to-output response time (SS_In, SLS_In, DM_In, ESM_In, LM_In)	-	20 ms
Overspeed response time	-	User-configurable
Inputs (S34)	-	5 mA per input, max
Conductor size ⁽¹⁾	0.3...0.8 mm ² (28...18 AWG)	0.25...2.5 mm ² (24...14 AWG)
Strip length	10 mm (0.39 in.)	6 mm (0.25 in.)
Terminal screw torque	-	0.2...0.25 N•m (1.8...2.2 lb•in)
Certification ⁽²⁾		
cULus	UL Listed, certified for US and Canada.	
CE	European Union 2004/108/EC EMC Directive, and EU 2006/42/EC Machinery Directive EN 61800-3; categories C2 and C3 EN 62061; EM Immunity EN ISO 13849-1 EN 61800-5-1 EN 61800-5-2 IEC 61508 Parts 1-7	
UKCA	Electromagnetic Compatibility Regulations (EMC) 2016 No. 1091 and Supply of Machinery (Safety) Regulations (MD) 2008 No. 1597 EN 61800-3; categories C2 and C3 EN 62061; EM Immunity EN ISO 13849-1 EN 61800-5-1 EN 61800-5-2 IEC 61508 Parts 1-7	
RCM	Australian Radiocommunications Act, compliant with EN 61800-3; categories C2 and C3	
TÜV	TÜV Certified for Functional Safety up to SIL CL3, according to EN 61800-5-2, EN 61508, and EN 62061. Up to Performance Level PLe and Category 3, according to EN ISO 13849-1.	TÜV Certified for Functional Safety up to SIL CL3, according to EN 61800-5-2, EN 61508, and EN 62061. Up to Performance Level PLe and Category 4, according to EN ISO 13849-1.

(1) See Industrial Automation Wiring and Grounding Guidelines, publication [1770-4.1](#).

(2) The certification applies if the product is marked.

(3) Safety outputs need additional fuse for reverse voltage protection of the control circuit. Install a 6 A slow-blow or 10 A fast-acting fuse.

Specifications - Integrated Safety Options

Attribute	Integrated Safe Torque Off, 20-750-S3	Integrated Safety Functions, 20-750-S4
Standards	EN 60204-1, IEC 61508, EN 61800-3, EN 61800-5-1, EN 61800-5-2, EN 62061, EN ISO 13489	EN 60204-1, IEC 61508, EN 61800-3, EN 61800-5-1, EN 61800-5-2, EN 62061, EN ISO 13849-1
Safety category	Cat. 3 and PLe per ISO 13849-1; SIL CL3 per IEC 61508 and EN 62061	Cat. 4 and PLe per EN ISO 13849-1; SIL 3 per IEC 61508 and SIL CL3 per EN IEC 62061
Power supply (user I/O)	24V DC $\pm 10\%$, 0.8...1.1 x rated voltage ⁽¹⁾ PELV or SELV	24V DC $\pm 10\%$, 0.8...1.1 x rated voltage ⁽¹⁾ PELV or SELV
Input type	Current sinking	Current sinking
Voltage, on-state input	11...30V, 3.5 mA DC	11...30V DC
Voltage, off-state input, max	5V, 3.5 mA DC	-3...5V DC
Current, on-state input, min	3.3 mA	2 mA
Current, off-state, max	1.3 mA	1.5 mA
IEC 61131-2 (input type)	Type 3	Type 3
Conductor type	Multi-conductor shielded cable	Multi-conductor shielded cable

Specifications - Integrated Safety Options (Continued)

Attribute	Integrated Safe Torque Off, 20-750-S3	Integrated Safety Functions, 20-750-S4
Conductor size ⁽²⁾	0.3...0.8 mm ² (28...18 AWG)	0.3...0.8 mm ² (28...18 AWG)
Strip length	10 mm (0.39 in.)	10 mm (0.39 in.)

(1) Safety outputs need additional fuse for reverse voltage protection of the control circuit. Install a 6 A slow-blow or 10 A fast-acting fuse.

(2) See the Industrial Automation Wiring and Grounding Guidelines, publication [1770-4.1](#).

PowerFlex 750-Series Drives Option Kits

This section provides information for PowerFlex 750-Series drives option kits.

PowerFlex 750-Series Drives Option Kits

Cat. No.	Description	Frame Size		
20-750-APS	Auxiliary power supply	24V auxiliary power supply	1...7 ⁽¹⁾	
20-750-DCBB1-F6	DC bus bar option kit	DC bus bars for 200...240 and 380...480V AC drives	6	
20-750-DCBB1-F7			7	
20-750-DCBB2-F6		DC bus bars for 600...690V AC drives	6	
20-750-DCBB2-F7			7	
20-750-BUSIA-F8	DC bus connection kit	Allows connection of the drive DC bus terminals to the bus rails at the back of the cabinet. ⁽²⁾	8	
20-750-EMC1-F1	EMC option kit	EMC plate with core for 200...240 and 380...480V AC drives	1	
20-750-EMC1-F2			2	
20-750-EMC1-F3			3	
20-750-EMC3-F3		EMC plate with core for 600V AC drives	3	
20-750-EMC1-F4		EMC plate with Cores for 200...240 and 380...480V AC drives	4	
20-750-EMC1-F5			5	
20-750-EMC3-F4		EMC plate with cores for 600V AC drives	4	
20-750-EMC3-F5			5	
20-750-EMC2-F1		EMC core for 200...240 and 380...480V AC drives	1	
20-750-EMC2-F2			2	
20-750-EMC2-F3			3	
20-750-EMC4-F3		EMC core for 600V AC drives	3	
20-750-EMC2-F45		EMC cores for 200...240 and 380...480V AC drives	4...5	
20-750-EMC4-F4		EMC cores for 600V AC drives	4	
20-750-EMC4-F5			5	
20-750-EMC3-F6		EMC plate with cores for 600...690V AC drives	6	
20-750-EMC3-F7			7	
20-750-EMC5-F6		EMC plate with cores for 600...690V AC drives (only IP54)	6	
20-750-EMC5-F7			7	
20-750-EMCCM1-F8		EMC core - inverter-mounted output, for 380...690V AC Input and DC Input drives. ⁽³⁾	8...10	
20-750-EMCSSM1-F8		EMC cores - required when using the Safe Speed Monitor option, catalog number 20-750-S1, with 380...690V drives.	8...10	
20-750-HOOD1-F8		Exhaust hood	Exhaust Hood - IP20, NEMA/UL Type 1 drives	8
20-750-FLNG1-F2		Flange adapter kit	Converts Open Type drive to external heatsink (flange) with NEMA/UL Type 1 integrity backside. This kit is for use with IP20, NEMA/UL Type 0 drives and does not provide an airtight or watertight seal. Where an airtight or watertight seal is required (for example, contaminated, dirty, or wet environments), use a drive with an "F" enclosure option.	2
20-750-FLNG1-F3				3
20-750-FLNG1-F4				4
20-750-FLNG1-F5				5
20-750-FLNG4-F6			Converts Open Type drive to external heatsink (flange) with NEMA/UL Type 4X/12 integrity backside.	6
20-750-FLNG4-F7	7			
20-750-LBRKT1	L bus bar kit			Includes three L-brackets

PowerFlex 750-Series Drives Option Kits (Continued)

Cat. No.	Description		Frame Size
20-750-NEMA1-F1	NEMA/UL Type 1 Option Kit	NEMA/UL Type 1 Kit	1
20-750-NEMA1-F2			2
20-750-NEMA1-F3			3
20-750-NEMA1-F4			4
20-750-NEMA1-F5			5
20-750-NEMA1-F6			6
20-750-NEMA1-F7			7
20-750-ACTE1-F6	Power terminal extension	Allows connection of two parallel leads to the AC power terminals.	6
20-750-PTG1-F6	Power terminal guard	Provides additional protection against contact with the power terminals.	6
20-750-PTG1-F7			7
20-750-RPD1-F8	Remote control POD mounting kit	Fiber-optic and power supply cables that are used to mount the control POD up to 23 m (75 ft) from the drive.	8...10
20-750-CART1-F8	Roll-out cart	A wheeled roll-out cart that facilitates drive installation and removal. Required for Frame 8 and larger drives.	8...10
20-750-MPLT755T	PowerFlex 750-Series Service Cart Conversion Kit	This kit attaches to the 20-750-MCART1. It enables the removal of power cores from PowerFlex 755 floor mount drives using the PowerFlex 755T drive service cart.	8...10

- (1) Frame 8 and up drives can be powered from an external 24V DC source, option kit catalog number 20-750-APS is not required.
- (2) DC bus access is included with Frames 9 and 10.
- (3) Frame 8 requires one EMC output core, Frame 9 requires two EMC output cores, and Frame 10 requires three EMC output cores.

PowerFlex 755 IP00, NEMA/UL Open Type Drive Options

This section provides information for PowerFlex 755 IP00, NEMA/UL Open Type drive options.

PowerFlex 755 IP00, NEMA/UL Open Type Drive Options

Description	Required?	Frame 8		Frame 9		Frame 10	
		Cat. No.	Qty.	Cat. No.	Qty.	Cat. No.	Qty.
Field termination, converter, AC input	Recommended	20-750-BUS2-F8	1	20-750-BUS2-F9	1	20-750-BUS2-F10	1
Field termination, inverter, AC output	Recommended	20-750-BUS3-F8	1	20-750-BUS3-F9	1	20-750-BUS3-F10	1
Field termination, DC bus, 400/480V	Recommended	20-750-BUS4-F8	1	20-750-BUS4-F9	1	20-750-BUS4-F10	1
Field termination, DC bus, 600/690V	Recommended	20-750-BUS4-F8	1	20-750-BUS6-F9	1	20-750-BUS6-F10	1
Field termination, DC input, common bus precharge ⁽¹⁾⁽²⁾	Recommended	20-750-BUS5-F8	1	20-750-BUS5-F9	1	20-750-BUS5-F10	1
Pod bucket assembly	Required	20-750-POD1-F8	1	20-750-POD1-F8	1	20-750-POD1-F8	1
Pod, cable, 24V supply ⁽³⁾	Required	20-750-PH1-F8	⁽⁴⁾	20-750-PH2-F9	1	20-750-PH3-F10	1
Cable, fiber-optic, 560 mm (22 in.) ⁽³⁾	Required	20-750-FCBL1-F8	1	-	-	-	-
Cable, fiber-optic, 2.8 m (110 in.) ⁽³⁾	Required	-	-	20-750-FCBL1-F10	2	20-750-FCBL1-F10	3
Transceiver, fiber-optic	Required	See EU and UK Ecodesign following this table.					
Pod, remote mounting kit	Optional	20-750-RPD1-F8	1	-	-	-	-
Mounting kit, back panel	Recommended	20-750-MNT2-F8	1	20-750-MNT2-F9	1	20-750-MNT2-F10	1
Mounting kit, floor	Recommended	20-750-MNT3-F8	1	20-750-MNT3-F9	1	20-750-MNT3-F10	1
Duct, top outlet	Recommended	20-750-DUCT2-F8	1	20-750-DUCT2-F8	2	20-750-DUCT2-F8	3
Duct, bottom inlet	Recommended	20-750-DUCT4-F8	1	20-750-DUCT4-F8	2	20-750-DUCT4-F8	3
Roll-out cart	Recommended	20-750-CART1-F8	1	20-750-CART1-F8	1	20-750-CART1-F8	1
Control power circuit breaker ⁽²⁾	Recommended	1489-A2D130	1	1489-A2D130	2	1489-A2D130	3
Control power circuit breaker lock ⁽²⁾	Recommended	1489-AALOA	1	1489-AALOA	2	1489-AALOA	3
EMC core, converter input, AC input	Optional	20-750-EMCBUS1-F8	1	20-750-EMCBUS1-F8	2	20-750-EMCBUS1-F8	3
EMC core, inverter output	Optional	20-750-EMCCM1-F8	1	20-750-EMCCM1-F8	2	20-750-EMCCM1-F8	3

- (1) EMC cores are included with the catalog number 20-750-BUS5-Fx kits.
- (2) Common DC input drives only.
- (3) If the control pod is mounted in the drive, use catalog number 20-750-PH1-Fx and catalog number 20-750-FCBL1-Fx kits. If the control pod is remote-mounted (up to 23 m [75 ft] away), order catalog number 20-750-RPD1-Fx kit.
- (4) A 24V supply cable is included with each Frame 8 drive unit.

EU and UK Ecodesign

This table provides required information per Ecodesign Regulation (EU) 548/2014 and its amendments. The following table includes control transformers with a minimum power rating of 1 kVA used in 50 Hz applications that are used in PowerFlex 755 frame 8 drives and up.

Energy Efficiency Data for 1 kVA Transformers used in IP00 Open Type Kits

Cat. No.	Rated Power (VA)	Primary Voltage	Secondary Voltage	Frequency (Hz)	Core	Core Weight [kg (lb)]	Conductor	Conductor Weight [kg (lb)]	Full Load Losses (W)	No Load Losses (W) ⁽¹⁾	Qty
SK-R1-XFMR1-F8	1000	415/480/600/690V	240V	50/60	Steel	6.7 (14.8)	Copper	1.50 (3.31)	86	40	2
SK-R1-OFANXFMR	1000	120/240V	120/230V	50/60	Steel	10.2 (22.5)	Copper	2.29 (5.04)	88.2	31.1	2
SK-R1-CBPXFMR1-F8	1000	415/480/600/690V	120/240V	50/60	Steel	6.8 (15.1)	Copper	1.40 (3.08)	76.2	20.4	2

(1) Electrical power of any cooling system required at no load.

Internal Dynamic Brake Resistor Kits

These resistors have a limited duty cycle. To determine whether an internal resistor is sufficient for your application, see the PowerFlex Dynamic Braking Resistor Calculator Application Technique, publication [PFLEX-AT001](#). An external resistor can be required.

Cat. No.	Drive Input Voltage	Frame	Rating (ND kW)	Rating (ND Hp)	Brake Resistance
20-750-DB1-D1	200...240V AC	1	0.37...0.75	0.5...1	62 Ω
20-750-DB1-B1			1.5...4	2...5	22 Ω
20-750-DB1-B2		2	0.37...5.5	0.5...7.5	22 Ω
20-750-DB1-D1A	380...480V AC	1	0.75...2.2	1...3	115 Ω
20-750-DB1-D1			4...7.5	5...10	62 Ω
20-750-DB1-D2		2	0.75...11	1...15	62 Ω

Terminators

This table provided information for terminators.

Cat. No.	Description ⁽¹⁾
1204-TFA1	For use with 3.7 kW (5 Hp) and lower drives.
1204-TFB2	For use with 1.5 kW (2 Hp) and higher drives.

(1) For selection information, see Appendix A of the Wiring and Grounding Guidelines for Pulse Width Modulated (PWM) AC Drives, publication [DRIVES-IN001](#).

Reflected Wave Reduction Modules with Common Mode Choke

This table provided information for reflected wave reduction modules with common mode choke.

Cat. No.	Description ⁽¹⁾
1204-RWC-17-A	17 A with common mode choke

(1) For selection information, see Appendix A of the Wiring and Grounding Guidelines for Pulse Width Modulated (PWM) AC Drives, publication [DRIVES-IN001](#).

460V, 60 Hz, Three-phase, 460V Primary and 460V Secondary

Motor Rating		Wiring Diagram	Cat. No.
kW	Hp		
0.75	1	1	1321-3TW005-BB
1.5	2	1	1321-3TW005-BB
2.2	3	1	1321-3TW005-BB
22	30	2	1321-3TW040-BB
30	40	2	1321-3TW051-BB
37	50	2	1321-3TH063-BB
45	60	2	1321-3TH075-BB
55	75	2	1321-3TH093-BB
75	100	2	1321-3TH118-BB
90	125	2	1321-3TH145-BB

Motor Rating		Wiring Diagram	Cat. No.
kW	Hp		
110	150	2	1321-3TH175-BB
149	200	2	1321-3TH220-BB
187	250	2	1321-3TH275-BB
224	300	2	1321-3TH330-BB
261	350	1	1321-3TH440-BB
298	400	1	1321-3TH440-BB
336	450	1	1321-3TH550-BB
373	500	1	1321-3TH550-BB
448	600	1	1321-3TH660-BB
485	650	1	-

Motor Rating		Wiring Diagram	Cat. No.
kW	Hp		
522	700	1	1321-3TH770-BB
560	750	1	1321-3TH770-BB
597	800	1	1321-3TH880-BB
671	900	900 kVA	A 1321 isolation transformer solution is not available. Approximate drive kVA is shown at left.
746	1000	1000 kVA	
821	1100	1200 kVA	
933	1250	1200 kVA	
1007	1350	1300 kVA	
1119	1500	1500 kVA	
1492	2000	2000 kVA	

575V, 60 Hz, Three-phase, 575V Primary, and 575V Secondary

Motor Rating		Wiring Diagram	Cat. No.
kW	Hp		
0.75	1	1	1321-3TW005-CC
1.5	2	1	1321-3TW005-CC
2.2	3	1	1321-3TW005-CC
22	30	2	1321-3TW040-CC
30	40	2	1321-3TW051-CC
37	50	2	1321-3TH063-CC
45	60	2	1321-3TH075-CC
55	75	2	1321-3TH093-CC
75	100	1	1321-3TH118-CC

Motor Rating		Wiring Diagram	Cat. No.
kW	Hp		
90	125	1	1321-3TH145-CC
110	150	1	1321-3TH175-CC
149	200	1	1321-3TH220-CC
187	250	1	1321-3TH275-CC
224	300	1	1321-3TH330-CC
261	350	1	1321-3TH440-CC
298	400	1	1321-3TH550-CC
336	450	1	1321-3TH550-CC
373	500	1	1321-3TH660-CC

Motor Rating		Wiring Diagram	Cat. No.
kW	Hp		
410	550	1	1321-3TH660-CC
448	600	1	1321-3TH770-CC
522	700	1	1321-3TH770-CC
597	800	1	1321-3TH880-CC
671	900	950 kVA	A 1321 isolation transformer solution is not available. Approximate drive kVA is shown at left.
709	950	1000 kVA	
746	1000	1100 kVA	
895	1200	1200 kVA	
1119	1500	1500 kVA	

Input and Output Reactors

This section provides information for input and output reactors.

200...240V, 60 Hz, Three-phase, 3% Impedance

kW	Hp	Duty	Input Line Reactor		Output Load Reactor	
			IPO0 (Open Style)	IP11 (NEMA/UL Type 1)	IPO0 (Open Style)	IP11 (NEMA/UL Type 1)
			Cat. No.	Cat. No.	Cat. No.	Cat. No.
0.37	0.5	Normal	1321-3R2-D	1321-3RA2-D	1321-3R2-D	1321-3RA2-D
		Heavy	1321-3R2-D	1321-3RA2-D	1321-3R4-A	1321-3RA4-A
0.75	1	Normal	1321-3R4-A	1321-3RA4-A	1321-3R4-A	1321-3RA4-B
		Heavy	1321-3R4-A	1321-3RA4-A	1321-3R8-A	1321-3RA8-A
1.5	2	Normal	1321-3R8-A	1321-3RA8-A	1321-3R8-A	1321-3RA8-A
		Heavy	1321-3R8-A	1321-3RA8-A	1321-3R12-A	1321-3RA12-A
2.2	3	Normal	1321-3R12-A	1321-3RA12-A	1321-3R12-A	1321-3RA12-A
		Heavy	1321-3R12-A	1321-3RA12-A	1321-3R18-A	1321-3RA18-A
4	5	Normal	1321-3R18-A	1321-3RA18-A	1321-3R18-A	1321-3RA18-A
		Heavy	1321-3R18-A	1321-3RA18-A	1321-3R25-A	1321-3RA25-A
5.5	7.5	Normal	1321-3R25-A	1321-3RA25-A	1321-3R25-A	1321-3RA25-A
		Heavy	1321-3R25-A	1321-3RA25-A	1321-3R35-A	1321-3RA35-A
7.5	10	Normal	1321-3R35-A	1321-3RA35-A	1321-3R35-A	1321-3RA35-A
		Heavy	1321-3R35-A	1321-3RA35-A	1321-3R45-A	1321-3RA45-A
11	15	Normal	1321-3R45-A	1321-3RA45-A	1321-3R45-A	1321-3RA45-A
		Heavy	1321-3R45-A	1321-3RA45-A	1321-3R55-A	1321-3RA55-A

200...240V, 60 Hz, Three-phase, 3% Impedance (Continued)

kW	Hp	Duty	Input Line Reactor		Output Load Reactor	
			IP00 (Open Style)	IP11 (NEMA/UL Type 1)	IP00 (Open Style)	IP11 (NEMA/UL Type 1)
			Cat. No.	Cat. No.	Cat. No.	Cat. No.
15	20	Normal	1321-3R55-A	1321-3RA55-A	1321-3R55-A	1321-3RA55-A
		Heavy	1321-3R55-A	1321-3RA55-A	1321-3R80-A	1321-3RA80-A
18.5	25	Normal	1321-3R80-A	1321-3RA80-A	1321-3R80-A	1321-3RA80-A
		Heavy	1321-3R80-A	1321-3RA80-A	1321-3R80-A	1321-3RA80-A
22	30	Normal	1321-3R80-A	1321-3RA80-A	1321-3R80-A	1321-3RA80-A
		Heavy	1321-3R80-A	1321-3RA80-A	1321-3R100-A	1321-3RA100-A
30	40	Normal	1321-3R100-A	1321-3RA100-A	1321-3R100-A	1321-3RA100-A
		Heavy	1321-3R100-A	1321-3RA100-A	1321-3R130-A	1321-3RA130-A
37	50	Normal	1321-3R130-A	1321-3RA130-A	1321-3R130-A	1321-3RA130-A
		Heavy	1321-3R130-A	1321-3RA130-A	1321-3R160-A	1321-3RA160-A
45	60	Normal	1321-3R160-A	1321-3RA160-A	1321-3R160-A	1321-3RA160-A
		Heavy	1321-3R160-A	1321-3RA160-A	1321-3R200-A	1321-3RA200-A
55	75	Normal	1321-3R200-A	1321-3RA200-A	1321-3R200-A	1321-3RA200-A
		Heavy	1321-3R200-A	1321-3RA200-A	1321-3RB320-A	1321-3RAB320-A
66	100	Normal	1321-3RB320-A	1321-3RAB320-A	1321-3RB320-A	1321-3RAB320-A
		Heavy	1321-3RB320-A	1321-3RAB320-A	1321-3RB320-A	1321-3RAB320-A
90	125	Normal	1321-3RB320-A	1321-3RAB320-A	1321-3RB320-A	1321-3RAB320-A
		Heavy	1321-3RB320-A	1321-3RAB320-A	1321-3RB400-A	1321-3RAB400-A
110	150	Normal	1321-3RB400-A	1321-3RAB400-A	1321-3RB400-A	1321-3RAB400-A
132	200	Normal	1321-3R500-A	1321-3RA500-A	1321-3R500-A	1321-3RA500-B

200...240V, 60 Hz, Three-phase, 5% Impedance

kW	Hp	Duty	Input Line Reactor		Output Load Reactor	
			IP00 (Open Style)	IP11 (NEMA/UL Type 1)	IP00 (Open Style)	IP11 (NEMA/UL Type 1)
			Cat. No.	Cat. No.	Cat. No.	Cat. No.
0.37	0.5	Normal	1321-3R2-A	1321-3RA2-A	1321-3R2-A	1321-3RA2-A
		Heavy	1321-3R2-A	1321-3RA2-A	1321-3R4-A	1321-3RA4-A
0.75	1	Normal	1321-3R4-B	1321-3RA4-B	1321-3R4-B	1321-3RA4-B
		Heavy	1321-3R4-B	1321-3RA4-B	1321-3R8-B	1321-3RA8-B
1.5	2	Normal	1321-3R8-B	1321-3RA8-B	1321-3R8-B	1321-3RA8-B
		Heavy	1321-3R8-B	1321-3RA8-B	1321-3R12-B	1321-3RA12-B
2.2	3	Normal	1321-3R12-B	1321-3RA12-B	1321-3R12-B	1321-3RA12-B
		Heavy	1321-3R12-B	1321-3RA12-B	1321-3R18-B	1321-3RA18-B
4	5	Normal	1321-3R18-B	1321-3RA18-B	1321-3R18-B	1321-3RA18-B
		Heavy	1321-3R18-B	1321-3RA18-B	1321-3R25-B	1321-3RA25-B
5.5	7.5	Normal	1321-3R25-B	1321-3RA25-B	1321-3R25-B	1321-3RA25-B
		Heavy	1321-3R25-B	1321-3RA25-B	1321-3R35-B	1321-3RA35-B
7.5	10	Normal	1321-3R35-B	1321-3RA35-B	1321-3R35-B	1321-3RA35-B
		Heavy	1321-3R35-B	1321-3RA35-B	1321-3R45-B	1321-3RA45-B
11	15	Normal	1321-3R45-B	1321-3RA45-B	1321-3R45-B	1321-3RA45-B
		Heavy	1321-3R45-B	1321-3RA45-B	1321-3R55-B	1321-3RA55-B
15	20	Normal	1321-3R55-B	1321-3RA55-B	1321-3R55-B	1321-3RA55-B
		Heavy	1321-3R55-B	1321-3RA55-B	1321-3R80-B	1321-3RA80-B
18.5	25	Normal	1321-3R80-B	1321-3RA80-B	1321-3R80-B	1321-3RA80-B
		Heavy	1321-3R80-B	1321-3RA80-B	1321-3R80-B	1321-3RA80-B

200...240V, 60 Hz, Three-phase, 5% Impedance (Continued)

kW	Hp	Duty	Input Line Reactor		Output Load Reactor	
			IPO0 (Open Style)	IP11 (NEMA/UL Type 1)	IPO0 (Open Style)	IP11 (NEMA/UL Type 1)
			Cat. No.	Cat. No.	Cat. No.	Cat. No.
22	30	Normal	1321-3R80-B	1321-3RA80-B	1321-3R80-B	1321-3RA80-B
		Heavy	1321-3R80-B	1321-3RA80-B	1321-3R100-B	1321-3RA100-B
30	40	Normal	1321-3R100-B	1321-3RA100-B	1321-3R100-B	1321-3RA100-B
		Heavy	1321-3R100-B	1321-3RA100-B	1321-3R130-B	1321-3RA130-B
37	50	Normal	1321-3R130-B	1321-3RA130-B	1321-3R130-B	1321-3RA130-B
		Heavy	1321-3R130-B	1321-3RA130-B	1321-3R160-B	1321-3RA160-B
45	60	Normal	1321-3R160-B	1321-3RA160-B	1321-3R160-B	1321-3RA160-B
		Heavy	1321-3R160-B	1321-3RA160-B	1321-3R200-B	1321-3RA200-B
55	75	Normal	1321-3R200-B	1321-3RA200-B	1321-3R200-B	1321-3RA200-B
		Heavy	1321-3R200-B	1321-3RA200-B	1321-3RB320-B	1321-3RAB320-B
66	100	Normal	1321-3RB320-B	1321-3RAB320-B	1321-3RB320-B	1321-3RAB320-B
		Heavy	1321-3RB320-B	1321-3RAB320-B	1321-3RB320-B	1321-3RAB320-B
90	125	Normal	1321-3RB320-B	1321-3RAB320-B	1321-3RB320-B	1321-3RAB320-B
		Heavy	1321-3RB320-B	1321-3RAB320-B	1321-3RB400-B	1321-3RAB400-B
110	150	Normal	1321-3RB400-B	1321-3RAB400-B	1321-3RB400-B	1321-3RAB400-B
132	200	Normal	1321-3R500-B	1321-3RA500-B	1321-3R500-B	1321-3RA500-B

380...480V, 50/60 Hz, Three-phase, 3% Impedance

kW	Hp	Duty	Input Line Reactor		Output Load Reactor	
			IPO0 (Open Style)	IP11 (NEMA/UL Type 1)	IPO0 (Open Style)	IP11 (NEMA/UL Type 1)
			Cat. No.	Cat. No.	Cat. No.	Cat. No.
0.75	1	Normal	1321-3R2-A	1321-3RA2-A	1321-3R2-A	1321-3RA2-A
1.1	1.5	Heavy	1321-3R4-C	1321-3RA4-C	1321-3R4-B	1321-3RA4-B
1.5	2	Normal	1321-3R4-B	1321-3RA4-B	1321-3R4-B	1321-3RA4-B
		Heavy	1321-3R4-B	1321-3RA4-B	1321-3R8-C	1321-3RA8-C
2.2	3	Normal	1321-3R8-C	1321-3RA8-C	1321-3R8-C	1321-3RA8-C
		Heavy	1321-3R8-C	1321-3RA8-C	1321-3R8-B	1321-3RA8-B
4	5	Normal	1321-3R8-B	1321-3RA8-B	1321-3R8-B	1321-3RA8-B
		Heavy	1321-3R8-B	1321-3RA8-B	1321-3R12-B	1321-3RA12-B
5.5	7.5	Normal	1321-3R12-B	1321-3RA12-B	1321-3R12-B	1321-3RA12-B
		Heavy	1321-3R12-B	1321-3RA12-B	1321-3R18-B	1321-3RA18-B
7.5	10	Normal	1321-3R18-B	1321-3RA18-B	1321-3R18-B	1321-3RA18-B
		Heavy	1321-3R18-B	1321-3RA18-B	1321-3R25-B	1321-3RA25-B
11	15	Normal	1321-3R25-B	1321-3RA25-B	1321-3R25-B	1321-3RA25-B
		Heavy	1321-3R25-B	1321-3RA25-B	1321-3R25-B	1321-3RA25-B
15	20	Normal	1321-3R35-B	1321-3RA35-B	1321-3R25-B	1321-3RA25-B
		Heavy	1321-3R35-B	1321-3RA35-B	1321-3R35-B	1321-3RA35-B
18.5	25	Normal	1321-3R35-B	1321-3RA35-B	1321-3R35-B	1321-3RA35-B
		Heavy	1321-3R35-B	1321-3RA35-B	1321-3R45-B	1321-3RA45-B
22	30	Normal	1321-3R45-B	1321-3RA45-B	1321-3R45-B	1321-3RA45-B
		Heavy	1321-3R45-B	1321-3RA45-B	1321-3R55-B	1321-3RA55-B
30	40	Normal	1321-3R55-B	1321-3RA55-B	1321-3R55-B	1321-3RA55-B
		Heavy	1321-3R55-B	1321-3RA55-B	1321-3R80-B	1321-3RA80-B
37	50	Normal	1321-3R80-B	1321-3RA80-B	1321-3R80-B	1321-3RA80-B
		Heavy	1321-3R80-B	1321-3RA80-B	1321-3R80-B	1321-3RA80-B

380...480V, 50/60 Hz, Three-phase, 3% Impedance (Continued)

kW	Hp	Duty	Input Line Reactor		Output Load Reactor	
			IP00 (Open Style)	IP11 (NEMA/UL Type 1)	IP00 (Open Style)	IP11 (NEMA/UL Type 1)
			Cat. No.	Cat. No.	Cat. No.	Cat. No.
45	60	Normal	1321-3R80-B	1321-3RA80-B	1321-3R80-B	1321-3RA80-B
		Heavy	1321-3R80-B	1321-3RA80-B	1321-3R80-B	1321-3RA80-B
55	75	Normal	1321-3R100-B	1321-3RA100-B	1321-3R100-B	1321-3RA100-B
		Heavy	1321-3R100-B	1321-3RA100-B	1321-3R100-B	1321-3RA100-B
75	100	Normal	1321-3R130-B	1321-3RA130-B	1321-3R130-B	1321-3RA130-B
		Heavy	1321-3R130-B	1321-3RA130-B	1321-3R130-B	1321-3RA130-B
90	125	Normal	1321-3R160-B	1321-3RA160-B	1321-3R160-B	1321-3RA160-B
		Heavy	1321-3R160-B	1321-3RA160-B	1321-3R160-B	1321-3RA160-B
110	150	Normal	1321-3R200-B	1321-3RA200-B	1321-3R200-C	1321-3RA200-C
		Heavy	1321-3R200-B	1321-3RA200-B	1321-3R200-C	1321-3RA200-C
-	200	Normal/Heavy	1321-3RB320-B	1321-3RB320-B	1321-3RB320-B	1321-3RB320-B
132	-	Normal/Heavy	1321-3RB320-B	1321-3RAB320-B	1321-3RB320-B	1321-3RAB320-B
160	250	Normal/Heavy	1321-3RB320-B	1321-3RAB320-B	1321-3RB320-B	1321-3RAB320-B
-	300	Normal/Heavy	1321-3RB400-B	1321-3RAB400-B	1321-3RB400-B	1321-3RAB400-B
200	-	Normal/Heavy	1321-3RB400-B	1321-3RAB400-B	1321-3RB400-B	1321-3RAB400-B
-	350	Normal/Heavy	1321-3R500-B	1321-3RA500-B	1321-3R500-B	1321-3RA500-B
250	-	Normal/Heavy	1321-3R500-B	1321-3RA500-B	1321-3R500-B	1321-3RA500-B
270	-	Normal/Heavy	1321-3R500-B	1321-3RA500-B	1321-3R500-B	1321-3RA500-B
-	400	Light/Normal/Heavy	1321-3R500-B	1321-3RA500-B	1321-3R500-B	1321-3RA500-B
315	-	Light/Normal/Heavy	1321-3R600-B	1321-3RA600-B	1321-3R600-B	1321-3RA600-B
-	450	Light/Normal/Heavy	1321-3R600-B	1321-3RA600-B	1321-3R600-B	1321-3RA600-B
355	-	Light/Normal/Heavy	1321-3R750-B	1321-3RA750-B	1321-3R750-B	1321-3RA750-B
-	500	Light	1321-3R600-B	1321-3RA600-B	1321-3R600-B	1321-3RA600-B
		Normal/Heavy	1321-3R750-B	1321-3RA750-B	1321-3R750-B	1321-3RA750-B
400	-	Light/Heavy	1321-3R750-B	1321-3RA750-B	1321-3R750-B	1321-3RA750-B
		Normal	1321-3R850-B	1321-3RA850-B	1321-3R850-B	1321-3RA850-B
-	600	Light/Normal/Heavy	1321-3R750-B	1321-3RA750-B	1321-3R750-B	1321-3RA750-B
450	-	Light	1321-3R850-B	1321-3RA850-B	1321-3R850-B	1321-3RA850-B
-	650	Light	1321-3R850-B	1321-3RA850-B	1321-3R850-B	1321-3RA850-B
		Normal	1321-3R750-B	1321-3RA750-B	1321-3R750-B	1321-3RA750-B
-	700	Light/Normal/Heavy	1321-3R850-B	1321-3RA850-B	1321-3R850-B	1321-3RA850-B
-	750	Heavy	1321-3R850-B	1321-3RA850-B	1321-3R850-B	1321-3RA850-B
500	-	Normal/Heavy	1321-3R1000-B	1321-3RA1000-B	1321-3R1000-B	1321-3RA1000-B
-	800	Light/Normal/Heavy	1321-3R1000-B	1321-3RA1000-B	1321-3R1000-B	1321-3RA1000-B
560	-	Light/Normal/Heavy	1321-3R600-B ⁽¹⁾	1321-3RA600-B ⁽¹⁾	1321-3R600-B ⁽¹⁾	1321-3RA600-B ⁽¹⁾
-	900	Light/Normal/Heavy	1321-3R600-B ⁽¹⁾	1321-3RA600-B ⁽¹⁾	1321-3R600-B ⁽¹⁾	1321-3RA600-B ⁽¹⁾
630	-	Light/Normal/Heavy	1321-3R600-B ⁽¹⁾	1321-3RA600-B ⁽¹⁾	1321-3R600-B ⁽¹⁾	1321-3RA600-B ⁽¹⁾
-	1000	Light/Normal/Heavy	1321-3R600-B ⁽¹⁾	1321-3RA600-B ⁽¹⁾	1321-3R600-B ⁽¹⁾	1321-3RA600-B ⁽¹⁾

380...480V, 50/60 Hz, Three-phase, 3% Impedance (Continued)

kW	Hp	Duty	Input Line Reactor		Output Load Reactor	
			IP00 (Open Style)	IP11 (NEMA/UL Type 1)	IP00 (Open Style)	IP11 (NEMA/UL Type 1)
			Cat. No.	Cat. No.	Cat. No.	Cat. No.
710	-	Light/Normal/Heavy	1321-3R600-B ⁽¹⁾	1321-3RA600-B ⁽¹⁾	1321-3R600-B ⁽¹⁾	1321-3RA600-B ⁽¹⁾
-	1100	Light/Normal	1321-3R750-B ⁽¹⁾	1321-3RA750-B ⁽¹⁾	1321-3R750-B ⁽¹⁾	1321-3RA750-B ⁽¹⁾
800	-	Light/Normal	1321-3R750-B ⁽¹⁾	1321-3RA750-B ⁽¹⁾	1321-3R750-B ⁽¹⁾	1321-3RA750-B ⁽¹⁾
-	1250	Light/Normal	1321-3R750-B ⁽¹⁾	1321-3RA750-B ⁽¹⁾	1321-3R750-B ⁽¹⁾	1321-3RA750-B ⁽¹⁾
850	-	Light/Normal	1321-3R750-B ⁽¹⁾	1321-3RA750-B ⁽¹⁾	1321-3R750-B ⁽¹⁾	1321-3RA750-B ⁽¹⁾
-	1350	Light	1321-3R850-B ⁽¹⁾	1321-3RA850-B ⁽¹⁾	1321-3R850-B ⁽¹⁾	1321-3RA850-B ⁽¹⁾
900	-	Light	1321-3R850-B ⁽¹⁾	1321-3RA850-B ⁽¹⁾	1321-3R850-B ⁽¹⁾	1321-3RA850-B ⁽¹⁾
-	1500	Light	1321-3R850-B ⁽²⁾	1321-3RA850-B ⁽²⁾	1321-3R850-B ⁽²⁾	1321-3RA850-B ⁽²⁾
1000	-	Light	1321-3R850-B ⁽²⁾	1321-3RA850-B ⁽²⁾	1321-3R850-B ⁽²⁾	1321-3RA850-B ⁽²⁾
-	2000	Light	1321-3R850-B ⁽²⁾	1321-3RA850-B ⁽²⁾	1321-3R850-B ⁽²⁾	1321-3RA850-B ⁽²⁾
1400	-	Light	1321-3R850-B ⁽²⁾	1321-3RA850-B ⁽²⁾	1321-3R850-B ⁽²⁾	1321-3RA850-B ⁽²⁾

(1) Requires two reactors that are wired in parallel.

(2) Requires three reactors that are wired in parallel.

380...480V, 50/60 Hz, Three-phase, 5% Impedance

kW	Hp	Duty	Input Line Reactor		Output Load Reactor	
			IP00 (Open Style)	IP11 (NEMA/UL Type 1)	IP00 (Open Style)	IP11 (NEMA/UL Type 1)
			Cat. No.	Cat. No.	Cat. No.	Cat. No.
0.75	1	Normal	1321-3R2-B	1321-3RA2-B	1321-3R2-B	1321-3RA2-B
1.1	1.5	Heavy	1321-3R4-D	1321-3RA4-D	1321-3R4-D	1321-3RA4-D
1.5	2	Normal	1321-3R4-D	1321-3RA4-D	1321-3R4-D	1321-3RA4-D
		Heavy	1321-3R4-D	1321-3RA4-D	1321-3R8-D	1321-3RA8-D
2.2	3	Normal	1321-3R8-D	1321-3RA8-D	1321-3R8-D	1321-3RA8-D
		Heavy	1321-3R8-D	1321-3RA8-D	1321-3R8-C	1321-3RA8-C
4	5	Normal	1321-3R8-C	1321-3RA8-C	1321-3R8-C	1321-3RA8-C
		Heavy	1321-3R8-C	1321-3RA8-C	1321-3R12-C	1321-3RA12-C
5.5	7.5	Normal	1321-3R12-C	1321-3RA12-C	1321-3R12-C	1321-3RA12-C
		Heavy	1321-3R12-C	1321-3RA12-C	1321-3R18-C	1321-3RA18-C
7.5	10	Normal	1321-3R18-C	1321-3RA18-C	1321-3R18-C	1321-3RA18-C
		Heavy	1321-3R18-C	1321-3RA18-C	1321-3R25-C	1321-3RA25-C
11	15	Normal/Heavy	1321-3R25-C	1321-3RA25-C	1321-3R25-C	1321-3RA25-C
15	20	Normal	1321-3R35-C	1321-3RA35-C	1321-3R25-C	1321-3RA25-C
		Heavy	1321-3R35-C	1321-3RA35-C	1321-3R35-C	1321-3RA35-C
18.5	25	Normal	1321-3R35-C	1321-3RA35-C	1321-3R35-C	1321-3RA35-C
		Heavy	1321-3R35-C	1321-3RA35-C	1321-3R45-C	1321-3RA45-C
22	30	Normal	1321-3R45-C	1321-3RA45-C	1321-3R45-C	1321-3RA45-C
		Heavy	1321-3R45-C	1321-3RA45-C	1321-3R55-C	1321-3RA55-C
30	40	Normal	1321-3R55-C	1321-3RA55-C	1321-3R55-C	1321-3RA55-C
		Heavy	1321-3R55-C	1321-3RA55-C	1321-3R80-C	1321-3RA80-C
37	50	Normal	1321-3R80-C	1321-3RA80-C	1321-3R80-C	1321-3RA80-C
		Heavy	1321-3R80-C	1321-3RA80-C	1321-3R80-C	1321-3RA80-C
45	60	Normal/Heavy	1321-3R80-C	1321-3RA80-C	1321-3R80-C	1321-3RA80-C
55	75	Normal/Heavy	1321-3R100-C	1321-3RA100-C	1321-3R100-C	1321-3RA100-C
75	100	Normal/Heavy	1321-3R130-C	1321-3RA130-C	1321-3R130-C	1321-3RA130-C

380...480V, 50/60 Hz, Three-phase, 5% Impedance (Continued)

kW	Hp	Duty	Input Line Reactor		Output Load Reactor	
			IP00 (Open Style)	IP11 (NEMA/UL Type 1)	IP00 (Open Style)	IP11 (NEMA/UL Type 1)
			Cat. No.	Cat. No.	Cat. No.	Cat. No.
90	125	Normal/Heavy	1321-3R160-C	1321-3RA160-C	1321-3R160-C	1321-3RA160-C
110	150	Normal	1321-3R200-C	1321-3RA200-C	1321-3R200-C	1321-3RA200-C
		Heavy	1321-3R200-C	1321-3RA200-C	1321-3R200-C	1321-3RA200-C
-	200	Normal/Heavy	1321-3RB250-C	1321-3RAB250-C	1321-3RB250-C	1321-3RAB250-C
132	-	Normal/Heavy	1321-3RB320-C	1321-3RAB320-C	1321-3RB320-C	1321-3RAB320-C
160	250	Normal/Heavy	1321-3RB320-C	1321-3RAB320-C	1321-3RB320-C	1321-3RAB320-C
-	300	Normal/Heavy	1321-3RB400-C	1321-3RAB400-C	1321-3RB400-C	1321-3RAB400-C
200	-	Normal/Heavy	1321-3RB400-C	1321-3RAB400-C	1321-3RB400-C	1321-3RAB400-C
-	350	Normal/Heavy	1321-3R500-C	1321-3RA500-C	1321-3R500-C	1321-3RA500-C
250	-	Normal/Heavy	1321-3R500-C	1321-3RA500-C	1321-3R500-C	1321-3RA500-C
270	-	Normal/Heavy	1321-3R500-C	1321-3RA500-C	1321-3R500-C	1321-3RA500-C
-	400	Light/Normal/Heavy	1321-3R500-C	1321-3RA500-C	1321-3R500-C	1321-3RA500-C
315	-	Light/Normal/Heavy	1321-3R600-C	1321-3RA600-C	1321-3R600-C	1321-3RA600-C
336	450	Normal/Heavy	1321-3RA600-C	1321-3RA600-C	1321-3R500-C	1321-3RA500-C
-	450	Light/Normal/Heavy	1321-3R600-C	1321-3RA600-C	1321-3R600-C	1321-3RA600-C
355	-	Light/Normal/Heavy	1321-3R750-C	1321-3RA750-C	1321-3R750-C	1321-3RA750-C
-	500	Light	1321-3R600-C	1321-3RA600-C	1321-3R600-C	1321-3RA600-C
		Normal/Heavy	1321-3R750-C	1321-3RA750-C	1321-3R750-C	1321-3RA750-C
400	-	Light/Heavy	1321-3R750-C	1321-3RA750-C	1321-3R750-C	1321-3RA750-C
-	-	Normal	1321-3R850-C	1321-3RA850-C	1321-3R850-C	1321-3RA850-C
-	600	Light/Normal/Heavy	1321-3R750-C	1321-3RA750-C	1321-3R750-C	1321-3RA750-C
450	-	Light	1321-3R850-C	1321-3RA850-C	1321-3R850-C	1321-3RA850-C
500	-	Normal/Heavy	1321-3R1000-C	1321-3RA1000-C	1321-3R1000-C	1321-3RA1000-C
-	650	Light	1321-3R850-C	1321-3RA850-C	1321-3R850-C	1321-3RA850-C
		Normal	1321-3R750-C	1321-3RA750-C	1321-3R750-C	1321-3RA750-C
-	700	Light/Normal/Heavy	1321-3R850-C	1321-3RA850-C	1321-3R850-C	1321-3RA850-C
-	750	Heavy	1321-3R850-C	1321-3RA850-C	1321-3R850-C	1321-3RA850-C
-	800	Light/Normal/Heavy	1321-3R1000-C	1321-3RA1000-C	1321-3R1000-C	1321-3RA1000-C
560	-	Light/Normal/Heavy	1321-3R600-C ⁽¹⁾	1321-3RA600-C ⁽¹⁾	1321-3R600-C ⁽¹⁾	1321-3RA600-C ⁽¹⁾
630	-	Light/Normal/Heavy	1321-3R600-C ⁽¹⁾	1321-3RA600-C ⁽¹⁾	1321-3R600-C ⁽¹⁾	1321-3RA600-C ⁽¹⁾
-	900	Light/Normal/Heavy	1321-3R600-C ⁽¹⁾	1321-3RA600-C ⁽¹⁾	1321-3R600-C ⁽¹⁾	1321-3RA600-C ⁽¹⁾
710	-	Light/Normal/Heavy	1321-3R600-C ⁽¹⁾	1321-3RA600-C ⁽¹⁾	1321-3R600-C ⁽¹⁾	1321-3RA600-C ⁽¹⁾
-	1000	Light/Normal/Heavy	1321-3R600-C ⁽¹⁾	1321-3RA600-C ⁽¹⁾	1321-3R600-C ⁽¹⁾	1321-3RA600-C ⁽¹⁾
-	1100	Light/Normal	1321-3R750-C ⁽¹⁾	1321-3RA750-C ⁽¹⁾	1321-3R750-C ⁽¹⁾	1321-3RA750-C ⁽¹⁾
800	-	Light/Normal	1321-3R750-C ⁽¹⁾	1321-3RA750-C ⁽¹⁾	1321-3R750-C ⁽¹⁾	1321-3RA750-C ⁽¹⁾
850	-	Light/Normal	1321-3R750-C ⁽¹⁾	1321-3RA750-C ⁽¹⁾	1321-3R750-C ⁽¹⁾	1321-3RA750-C ⁽¹⁾
-	1250	Light/Normal	1321-3R750-C ⁽¹⁾	1321-3RA750-C ⁽¹⁾	1321-3R750-C ⁽¹⁾	1321-3RA750-C ⁽¹⁾

380...480V, 50/60 Hz, Three-phase, 5% Impedance (Continued)

kW	Hp	Duty	Input Line Reactor		Output Load Reactor	
			IPO0 (Open Style)	IP11 (NEMA/UL Type 1)	IPO0 (Open Style)	IP11 (NEMA/UL Type 1)
			Cat. No.	Cat. No.	Cat. No.	Cat. No.
900	-	Light	1321-3R850-C ⁽¹⁾	1321-3RA850-C ⁽¹⁾	1321-3R850-C ⁽¹⁾	1321-3RA850-C ⁽¹⁾
-	1350	Light	1321-3R850-C ⁽¹⁾	1321-3RA850-C ⁽¹⁾	1321-3R850-C ⁽¹⁾	1321-3RA850-C ⁽¹⁾
-	1500	Light	1321-3R850-C ⁽²⁾	1321-3RA850-C ⁽²⁾	1321-3R850-C ⁽²⁾	1321-3RA850-C ⁽²⁾
1000	-	Light	1321-3R850-C ⁽²⁾	1321-3RA850-C ⁽²⁾	1321-3R850-C ⁽²⁾	1321-3RA850-C ⁽²⁾
-	2000	Light	1321-3R850-C ⁽²⁾	1321-3RA850-C ⁽²⁾	1321-3R850-C ⁽²⁾	1321-3RA850-C ⁽²⁾
1400	-	Light	1321-3R850-C ⁽²⁾	1321-3RA850-C ⁽²⁾	1321-3R850-C ⁽²⁾	1321-3RA850-C ⁽²⁾

(1) Requires two reactors that are wired in parallel.

(2) Requires three reactors that are wired in parallel.

600...690V, 50/60 Hz, Three-phase, 3% Impedance

kW	Hp	Duty	Input Line Reactor		Output Load Reactor	
			IPO0 (Open Style)	IP11 (NEMA/UL Type 1)	IPO0 (Open Style)	IP11 (NEMA/UL Type 1)
			Cat. No.	Cat. No.	Cat. No.	Cat. No.
-	0.5	Heavy	1321-3R1-C	1321-3RA1-C	1321-3R1-C	1321-3RA1-C
-	1	Normal	1321-3R2-B	1321-3RA2-B	1321-3R2-A	1321-3RA2-B
-		Heavy	1321-3R2-B	1321-3RA2-B	1321-3R4-A	1321-3RA4-A
-	2	Normal	1321-3R4-D	1321-3RA4-D	1321-3R4-C	1321-3RA4-C
-		Heavy	1321-3R4-C	1321-3RA4-C	1321-3R4-C	1321-3RA4-C
-	3	Normal/Heavy	1321-3R4-B	1321-3RA4-B	1321-3R4-B	1321-3RA4-B
-	5	Normal/Heavy	1321-3R8-C	1321-3RA8-C	1321-3R8-C	1321-3RA8-C
5.5	-	Heavy	1321-3R12-C	1321-3RA12-C	1321-3R12-C	1321-3RA12-C
-	7.5	Normal/Heavy	1321-3R12-B	1321-3RA12-B	1321-3R12-B	1321-3RA12-B
7.5	-	Normal	1321-3R12-B	1321-3RA12-B	1321-3R12-B	1321-3RA12-B
-		Heavy	1321-3R12-C	1321-3RA12-C	1321-3R18-C	1321-3RA18-C
-	10	Normal	1321-3R12-B	1321-3RA12-B	1321-3R12-B	1321-3RA12-B
-		Heavy	1321-3R12-B	1321-3RA12-B	1321-3R18-C	1321-3RA18-C
11	-	Normal/Heavy	1321-3R18-C	1321-3RA18-C	1321-3R18-C	1321-3RA18-C
-	15	Normal	1321-3R18-B	1321-3RA18-B	1321-3R18-B	1321-3RA18-B
-		Heavy	1321-3R25-B	1321-3RA25-B	1321-3R25-B	1321-3RA25-B
15	-	Normal/Heavy	1321-3R25-C	1321-3RA25-C	1321-3R25-C	1321-3RA25-C
-	20	Normal	1321-3R25-B	1321-3RA25-B	1321-3R25-B	1321-3RA25-B
-		Heavy	1321-3R35-B	1321-3RA35-B	1321-3R35-B	1321-3RA35-B
18.5	-	Normal/Heavy	1321-3R25-C	1321-3RA25-C	1321-3R25-C	1321-3RA25-C
-	25	Normal	1321-3R25-B	1321-3RA25-B	1321-3R35-B	1321-3RA35-B
22	-	Normal/Heavy	1321-3R35-C	1321-3RA35-C	1321-3R35-C	1321-3RA35-C
-	30	Normal/Heavy	1321-3R35-B	1321-3RA35-B	1321-3R35-B	1321-3RA35-B
30	-	Normal/Heavy	1321-3R35-C	1321-3RA35-C	1321-3R35-C	1321-3RA35-C
-	40	Normal/Heavy	1321-3R45-B	1321-3RA45-B	1321-3R45-B	1321-3RA45-B
37	-	Normal/Heavy	1321-3R45-B	1321-3RA45-B	1321-3R55-C	1321-3RA55-C
-	50	Normal/Heavy	1321-3R55-B	1321-3RA55-B	1321-3R55-B	1321-3RA55-B
45	-	Normal/Heavy	1321-3R55-B	1321-3RA55-B	1321-3R55-B	1321-3RA55-B
-	60	Normal/Heavy	1321-3R80-B	1321-3RA80-B	1321-3R80-B	1321-3RA80-B
55	-	Normal	1321-3R80-C	1321-3RA80-C	1321-3R80-B	1321-3RA80-B
-		Heavy	1321-3R80-B	1321-3RA80-B	1321-3R80-B	1321-3RA80-B
-	75	Normal/Heavy	1321-3R100-B	1321-3RA100-B	1321-3R100-B	1321-3RA100-B

600...690V, 50/60 Hz, Three-phase, 3% Impedance (Continued)

kW	Hp	Duty	Input Line Reactor		Output Load Reactor	
			IP00 (Open Style)	IP11 (NEMA/UL Type 1)	IP00 (Open Style)	IP11 (NEMA/UL Type 1)
			Cat. No.	Cat. No.	Cat. No.	Cat. No.
75		Normal/Heavy	1321-3R80-B	1321-3RA80-B	1321-3R80-B	1321-3RA80-B
-	100	Normal	1321-3R100-B	1321-3RA100-B	1321-3R100-B	1321-3RA100-B
		Heavy	1321-3R100-B	1321-3RA100-B	1321-3R130-B	1321-3RA130-B
90	-	Normal/Heavy	1321-3R100-B	1321-3RA100-B	1321-3R100-B	1321-3RA100-B
-	125	Normal/Heavy	1321-3R130-B	1321-3RA130-B	1321-3R130-B	1321-3RA130-B
110	-	Normal/Heavy	1321-3R130-C	1321-3RA130-C	1321-3R130-C	1321-3RA130-C
-	150	Normal	1321-3R160-B	1321-3RA160-B	1321-3R160-B	1321-3RA160-B
		Heavy	1321-3R200-B	1321-3RA200-B	1321-3R200-B	1321-3RA200-B
132	-	Normal/Heavy	1321-3R160-C	1321-3RA160-C	1321-3R160-C	1321-3RA160-C
-	200	Normal/Heavy	1321-3R200-B	1321-3RA200-B	1321-3R200-B	1321-3RA200-B
160	-	Normal	1321-3R160-C	1321-3RA160-C	1321-3R160-C	1321-3RA160-C
		Heavy	1321-3R200-C	1321-3RAB200-C	1321-3R200-C	1321-3RAB200-C
-	250	Normal/Heavy	1321-3R250-B	1321-3RA250-B	1321-3R250-B	1321-3RA250-B
-	300	Normal/Heavy	1321-3RB320-B	1321-3RAB320-B	1321-3RB320-B	1321-3RAB320-B
200	-	Normal	1321-3RB200-C	1321-3RAB200-C	1321-3RB200-C	1321-3RAB200-C
		Heavy	1321-3R200-C	1321-3RAB200-C	1321-3RB250-C	1321-3RAB250-C
		Heavy	1321-3R250-B	1321-3RA250-B	1321-3R250-B	1321-3RA250-B
-	350	Light/Normal/Heavy	1321-3RB400-B	1321-3RAB400-B	1321-3RB400-B	1321-3RAB400-B
250	-	Normal	1321-3RB250-C	1321-3RAB250-C	1321-3RB250-C	1321-3RAB250-C
		Normal/Heavy	1321-3RB320-B	1321-3RAB320-B	1321-3RB320-B	1321-3RAB320-B
-	400	Light/Normal/Heavy	1321-3RB400-B	1321-3RAB400-B	1321-3RB400-B	1321-3RAB400-B
300	-	Heavy	1321-3RB400-B	1321-3RAB400-B	1321-3RB400-B	1321-3RAB400-B
-	450	Light/Normal/Heavy	1321-3R500-B	1321-3RA500-B	1321-3R500-B	1321-3RA500-B
315	-	Light/Normal	1321-3RB400-B	1321-3RAB400-B	1321-3RB400-B	1321-3RAB400-B
-	500	Light/Normal	1321-3R600-B	1321-3RA600-B	1321-3R600-B	1321-3RA600-B
355	-	Light/Normal/Heavy	1321-3R500-B	1321-3RA500-B	1321-3R500-B	1321-3RA500-B
375	-	Heavy	1321-3R500-B	1321-3RA500-B	1321-3R500-B	1321-3RA500-B
400	-	Light/Normal/Heavy	1321-3R500-B	1321-3RA500-B	1321-3R500-B	1321-3RA500-B
450	-	Light/Normal	1321-3R600-B	1321-3RA600-B	1321-3R600-B	1321-3RA600-B
450	-	Heavy	1321-3R600-B	1321-3RA600-B	1321-3R600-B	1321-3RA600-B
500	-	Light/Normal	1321-3R600-B	1321-3RA600-B	1321-3R600-B	1321-3RA600-B
500	-	Heavy	1321-3R600-B	1321-3RA600-B	1321-3R600-B	1321-3RA600-B
530	-	Light	1321-3R600-B	1321-3RA600-B	1321-3R600-B	1321-3RA600-B
-	500	Heavy	1321-3R600-B	1321-3RA600-B	1321-3R600-B	1321-3RA600-B
-	550	Light	1321-3R600-B	1321-3RA600-B	1321-3R600-B	1321-3RA600-B
-	600	Normal/Heavy	1321-3R600-B	1321-3RA600-B	1321-3R600-B	1321-3RA600-B
-	700	Light/Normal/Heavy	1321-3R750-B	1321-3RA750-B	1321-3R750-B	1321-3RA750-B
560	-	Normal/Heavy	1321-3R750-B	1321-3RA750-B	1321-3R750-B	1321-3RA750-B
-	750	Heavy	1321-3R750-B	1321-3RA750-B	1321-3R750-B	1321-3RA750-B
630	-	Light/Normal/Heavy	1321-3R750-B	1321-3RA750-B	1321-3R750-B	1321-3RA750-B
-	800	Light/Normal/Heavy	1321-3R850-B	1321-3RA850-B	1321-3R850-B	1321-3RA850-B

600...690V, 50/60 Hz, Three-phase, 3% Impedance (Continued)

kW	Hp	Duty	Input Line Reactor		Output Load Reactor	
			IPO0 (Open Style)	IPT1 (NEMA/UL Type 1)	IPO0 (Open Style)	IPT1 (NEMA/UL Type 1)
			Cat. No.	Cat. No.	Cat. No.	Cat. No.
710	-	Light/Normal/Heavy	1321-3R850-B	1321-3RA850-B	1321-3R850-B	1321-3RA850-B
-	900	Light/Normal/Heavy	1321-3R850-B	1321-3RA850-B	1321-3R850-B	1321-3RA850-B
750	-	Normal	1321-3R850-B	1321-3RA850-B	1321-3R850-B	1321-3RA850-B
-	950	Light/Normal	1321-3R1000-B	1321-3RA1000-B	1321-3R1000-B	1321-3RA1000-B
800	-	Light/Normal/Heavy	1321-3R1000-B	1321-3RA1000-B	1321-3R1000-B	1321-3RA1000-B
-	1000	Light/Normal	1321-3R1000-B	1321-3RA1000-B	1321-3R1000-B	1321-3RA1000-B
850	-	Light	1321-3R1000-B	1321-3RA1000-B	1321-3R1000-B	1321-3RA1000-B
-	1100	Light	1321-3R600-B ⁽¹⁾	1321-3RA600-B ⁽¹⁾	1321-3R600-B ⁽¹⁾	1321-3RA600-B ⁽¹⁾
900	-	Light/Normal	1321-3R600-B ⁽¹⁾	1321-3RA600-B ⁽¹⁾	1321-3R600-B ⁽¹⁾	1321-3RA600-B ⁽¹⁾
1000	-	Light	1321-3R600-B ⁽¹⁾	1321-3RA600-B ⁽¹⁾	1321-3R600-B ⁽¹⁾	1321-3RA600-B ⁽¹⁾
1100	-	Light/Normal	1321-3R600-B ⁽²⁾	1321-3RA600-B ⁽²⁾	1321-3R600-B ⁽²⁾	1321-3RA600-B ⁽²⁾
-	1200	Light	1321-3R600-B ⁽²⁾	1321-3RA600-B ⁽²⁾	1321-3R600-B ⁽²⁾	1321-3RA600-B ⁽²⁾
1500	-	Light/Normal	1321-3R600-B ⁽²⁾	1321-3RA600-B ⁽²⁾	1321-3R600-B ⁽²⁾	1321-3RA600-B ⁽²⁾
-	1500	Light	1321-3R600-B ⁽²⁾	1321-3RA600-B ⁽²⁾	1321-3R600-B ⁽²⁾	1321-3RA600-B ⁽²⁾

(1) Requires two reactors that are wired in parallel.

(2) Requires three reactors that are wired in parallel.

600...690V, 50/60 Hz, Three-phase, 5% Impedance

kW	Hp	Duty	Input Line Reactor		Output Load Reactor	
			IPO0 (Open Style)	IPT1 (NEMA/UL Type 1)	IPO0 (Open Style)	IPT1 (NEMA/UL Type 1)
			Cat. No.	Cat. No.	Cat. No.	Cat. No.
-	0.5	Heavy	1321-3R1-C	1321-3RA1-C	1321-3R1-C	1321-3RA1-C
-	1	Normal	1321-3R2-C	1321-3RA2-C	1321-3R2-C	1321-3RA2-C
-		Heavy	1321-3R4-D	1321-3RA4-D	1321-3R2-D	1321-3RA4-D
-	2	Normal/Heavy	1321-3R4-D	1321-3RA4-D	1321-3R4-D	1321-3RA4-D
-	3	Normal/Heavy	1321-3R4-D	1321-3RA4-D	1321-3R4-D	1321-3RA4-D
-	5	Normal/Heavy	1321-3R8-D	1321-3RA8-D	1321-3R8-D	1321-3RA8-D
5.5	-	Heavy	1321-3R12-C	1321-3RA12-C	1321-3R12-C	1321-3RA12-C
-	7.5	Normal/Heavy	1321-3R12-C	1321-3RA12-C	1321-3R12-C	1321-3RA12-C
7.5	-	Normal/Heavy	1321-3R12-C	1321-3RA12-C	1321-3R12-C	1321-3RA12-C
-	10	Normal/Heavy	1321-3R12-C	1321-3RA12-C	1321-3R12-C	1321-3RA12-C
11	-	Normal/Heavy	1321-3R18-C	1321-3RA18-C	1321-3R18-C	1321-3RA18-C
-	15	Normal/Heavy	1321-3R18-C	1321-3RA18-C	1321-3R18-C	1321-3RA18-C
15	-	Normal/Heavy	1321-3R25-C	1321-3RA25-C	1321-3R25-C	1321-3RA25-C
-	20	Normal/Heavy	1321-3R25-C	1321-3RA25-C	1321-3R25-C	1321-3RA25-C
18.5	-	Normal/Heavy	1321-3R25-C	1321-3RA25-C	1321-3R25-C	1321-3RA25-C
-	25	Normal/Heavy	1321-3R35-C	1321-3RA35-C	1321-3R35-C	1321-3RA35-C
22	-	Normal/Heavy	1321-3R35-C	1321-3RA35-C	1321-3R35-C	1321-3RA35-C
-	30	Normal	1321-3R35-C	1321-3RA35-C	1321-3R35-C	1321-3RA35-C
-		Heavy	1321-3R45-C	1321-3RA45-C	1321-3R45-C	1321-3RA45-C
30	-	Normal/Heavy	1321-3R35-C	1321-3RA35-C	1321-3R35-C	1321-3RA35-C
-	40	Normal/Heavy	1321-3R45-C	1321-3RA45-C	1321-3R45-C	1321-3RA45-C
37	-	Normal/Heavy	1321-3R45-C	1321-3RA45-C	1321-3R45-C	1321-3RA45-C

600...690V, 50/60 Hz, Three-phase, 5% Impedance (Continued)

kW	Hp	Duty	Input Line Reactor		Output Load Reactor	
			IPO0 (Open Style)	IP11 (NEMA/UL Type 1)	IPO0 (Open Style)	IP11 (NEMA/UL Type 1)
			Cat. No.	Cat. No.	Cat. No.	Cat. No.
-	50	Normal/Heavy	1321-3R55-C	1321-3RA55-C	1321-3R55-C	1321-3RA55-C
45	-	Normal/Heavy	1321-3R55-C	1321-3RA55-C	1321-3R55-C	1321-3RA55-C
-	60	Normal/Heavy	1321-3R80-C	1321-3RA80-C	1321-3R80-C	1321-3RA80-C
55	-	Normal/Heavy	1321-3R80-C	1321-3RA80-C	1321-3R80-C	1321-3RA80-C
-	75	Normal/Heavy	1321-3R100-C	1321-3RA100-C	1321-3R100-C	1321-3RA100-C
75	-	Normal	1321-3R80-C	1321-3RA80-C	1321-3R80-C	1321-3RA80-C
		Heavy	1321-3R80-C	1321-3RA80-C	1321-3R100-C	1321-3RA100-C
-	100	Normal/Heavy	1321-3R100-C	1321-3RA100-C	1321-3R100-C	1321-3RA100-C
90	-	Normal/Heavy	1321-3R100-C	1321-3RA100-C	1321-3R100-C	1321-3RA100-C
-	125	Normal/Heavy	1321-3R130-C	1321-3RA130-C	1321-3R130-C	1321-3RA130-C
110	-	Normal/Heavy	1321-3R130-C	1321-3RA130-C	1321-3R130-C	1321-3RA130-C
132	-	Normal/Heavy	1321-3R160-C	1321-3RA160-C	1321-3R160-C	1321-3RA160-C
-	150	Normal/Heavy	1321-3R160-C	1321-3RA160-C	1321-3R160-C	1321-3RA160-C
160	-	Normal	1321-3R160-C	1321-3RA160-C	1321-3R160-C	1321-3RA160-C
		Heavy	1321-3RB200-C	1321-3RAB200-C	1321-3RB200-C	1321-3RAB200-C
-	200	Normal/Heavy	1321-3R200-C	1321-3RA200-C	1321-3R200-C	1321-3RA200-C
200	-	Normal	1321-3RB200-C	1321-3RAB200-C	1321-3RB200-C	1321-3RAB200-C
		Heavy	1321-3RB200-C	1321-3RAB200-C	1321-3RB250-C	1321-3RAB250-C
		Heavy	1321-3R250-C	1321-3RA250-C	1321-3R250-C	1321-3RA250-C
-	250	Normal/Heavy	1321-3RB250-C	1321-3RAB250-C	1321-3RB250-C	1321-3RAB250-C
-	300	Normal/Heavy	1321-3RB320-C	1321-3RAB320-C	1321-3RB320-C	1321-3RAB320-C
250	-	Normal/Heavy	1321-3RB320-C	1321-3RAB320-C	1321-3RB320-C	1321-3RAB320-C
-	350	Light/Normal/Heavy	1321-3RB400-C	1321-3RAB400-C	1321-3RB400-C	1321-3RAB400-C
-	400	Light/Normal/Heavy	1321-3RB400-C	1321-3RAB400-C	1321-3RB400-C	1321-3RAB400-C
300	-	Heavy	1321-3RB400-C	1321-3RAB400-C	1321-3RB400-C	1321-3RAB400-C
-	450	Light/Normal/Heavy	1321-3R500-C	1321-3RA500-C	1321-3R500-C	1321-3RA500-C
315	-	Light/Normal	1321-3RB400-C	1321-3RAB400-C	1321-3RB400-C	1321-3RAB400-C
-	500	Light/Normal/Heavy	1321-3R600-C	1321-3RA600-C	1321-3R600-C	1321-3RA600-C
355	-	Light/Normal/Heavy	1321-3R500-C	1321-3RA500-C	1321-3R500-C	1321-3RA500-C
-	550	Light	1321-3R600-C	1321-3RA600-C	1321-3R600-C	1321-3RA600-C
375	-	Heavy	1321-3R500-C	1321-3RA500-C	1321-3R500-C	1321-3RA500-C
400	-	Light/Normal/Heavy	1321-3R500-C	1321-3RA500-C	1321-3R500-C	1321-3RA500-C
450	-	Light/Normal/Heavy	1321-3R600-C	1321-3RA600-C	1321-3R600-C	1321-3RA600-C
500	-	Light/Normal	1321-3R600-C	1321-3RA600-C	1321-3R600-C	1321-3RA600-C
500	-	Heavy	1321-3R600-C	1321-3RA600-C	1321-3R600-C	1321-3RA600-C
530	-	Light	1321-3R600-C	1321-3RA600-C	1321-3R600-C	1321-3RA600-C
-	600	Normal/Heavy	1321-3R600-C	1321-3RA600-C	1321-3R600-C	1321-3RA600-C
-	700	Light/Normal/Heavy	1321-3R750-C	1321-3RA750-C	1321-3R750-C	1321-3RA750-C
560	-	Normal/Heavy	1321-3R750-C	1321-3RA750-C	1321-3R750-C	1321-3RA750-C
-	750	Heavy	1321-3R750-C	1321-3RA750-C	1321-3R750-C	1321-3RA750-C

600...690V, 50/60 Hz, Three-phase, 5% Impedance (Continued)

kW	Hp	Duty	Input Line Reactor		Output Load Reactor	
			IPO0 (Open Style)	IP11 (NEMA/UL Type 1)	IPO0 (Open Style)	IP11 (NEMA/UL Type 1)
			Cat. No.	Cat. No.	Cat. No.	Cat. No.
630	-	Light/Normal/Heavy	1321-3R750-C	1321-3RA750-C	1321-3R750-C	1321-3RA750-C
-	800	Light/Normal/Heavy	1321-3R850-C	1321-3RA850-C	1321-3R850-C	1321-3RA850-C
710	-	Light/Normal/Heavy	1321-3R850-C	1321-3RA850-C	1321-3R850-C	1321-3RA850-C
-	900	Light/Normal/Heavy	1321-3R850-C	1321-3RA850-C	1321-3R850-C	1321-3RA850-C
750	-	Normal	1321-3R850-C	1321-3RA850-C	1321-3R850-C	1321-3RA850-C
-	950	Light/Normal	1321-3R1000-C	1321-3RA1000-C	1321-3R1000-C	1321-3RA1000-C
800	-	Light/Normal/Heavy	1321-3R1000-C	1321-3RA1000-C	1321-3R1000-C	1321-3RA1000-C
-	1000	Light/Normal	1321-3R1000-C	1321-3RA1000-C	1321-3R1000-C	1321-3RA1000-C
850	-	Light	1321-3R1000-C	1321-3RA1000-C	1321-3R1000-C	1321-3RA1000-C
-	1100	Light	1321-3R600-C ⁽¹⁾	1321-3RA600-C ⁽¹⁾	1321-3R600-C ⁽¹⁾	1321-3RA600-C ⁽¹⁾
900	-	Light/Normal	1321-3R600-C ⁽¹⁾	1321-3RA600-C ⁽¹⁾	1321-3R600-C ⁽¹⁾	1321-3RA600-C ⁽¹⁾
1000	-	Light	1321-3R600-C ⁽¹⁾	1321-3RA600-C ⁽¹⁾	1321-3R600-C ⁽¹⁾	1321-3RA600-C ⁽¹⁾
1100	-	Light/Normal	1321-3R600-C ⁽²⁾	1321-3RA600-C ⁽²⁾	1321-3R600-C ⁽²⁾	1321-3RA600-C ⁽²⁾
-	1200	Light	1321-3R600-C ⁽²⁾	1321-3RA600-C ⁽²⁾	1321-3R600-C ⁽²⁾	1321-3RA600-C ⁽²⁾
1500	-	Light/Normal	1321-3R600-C ⁽²⁾	1321-3RA600-C ⁽²⁾	1321-3R600-C ⁽²⁾	1321-3RA600-C ⁽²⁾
-	1500	Light	1321-3R600-C ⁽²⁾	1321-3RA600-C ⁽²⁾	1321-3R600-C ⁽²⁾	1321-3RA600-C ⁽²⁾

(1) Requires two reactors that are wired in parallel.

(2) Requires three reactors that are wired in parallel.

Notes:

Additional Resources

These documents contain additional information concerning related products from Rockwell Automation.

Resource	Description
Motor Protection Circuit Breaker and Motor Circuit Protector Specifications, publication 140-TD005	Provides product selection and specification information for Bulletin 140MP/MT motor protection circuit breakers and motor circuit protectors.
PowerFlex 750-Series Drive Installation Instructions, publication 750-IN001	Provides detailed information on how to install PowerFlex® 750-Series AC drives.
PowerFlex 750-Series Programming Manual, publication 750-PM001	Provides detailed information on I/O, control, and feedback options; parameters and programming; faults, alarms, and troubleshooting.
PowerFlex 20-HIM-A6 and 20-HIM-C6S HIM (Human Interface Module) User Manual, publication 20HIM-UM001	Provides detailed information on HIM components, operation, and features.
PowerFlex 755 Integrated Safety - Safe Torque Off Option Module User Manual, publication 750-UM004	Provides detailed information on how to install and use the Integrated Safety - Safe Torque Off option module.
PowerFlex 750-Series Safe Torque Off User Manual, publication 750-UM002	Provides detailed information on how to install and use the Safe Torque Off option module.
Safe Speed Monitor Option Module for PowerFlex 750-Series AC Drives Safety Reference Manual, publication 750-RM001	Provides detailed information on how to install and use the Safe Speed Monitor option module.
PowerFlex 7-Class Network Communication Adapter User Manuals, publication 750COM-UM	These publications provide detailed information on to configure, use, and troubleshoot PowerFlex 750-Series communication option modules and adapters. To display a list of the available adapters, enter 750com-um in the search field.
PowerFlex Dynamic Braking Resistor Calculator Application Technique, publication PFLEX-AT001	Provides information to help you understand dynamic braking and how to apply dynamic braking to drive systems.
Wiring and Grounding Guidelines for PWM AC Drives, publication DRIVES-IN001	Provides basic information to properly wire and ground PWM AC drives.
Preventive Maintenance of Industrial Control and Drive System Equipment Service Bulletin, publication DRIVES-TD001	Provides information for preventative maintenance and periodic inspection of drive systems.
PowerFlex 750-Series Service Cart Frames 8...10 Conversion Kit, publication 750-IN017	Provides information on installing the frames 8...10 conversion kit to the PowerFlex 750-Series Service Cart.
PowerFlex 750-Series Service Cart and DCPC Lift Renewal Parts, publication 750-PC106	Provides additional information to acquire spare parts for the PowerFlex 750-Series.
PowerFlex 750-Series Service Cart and DCPC Module Lift Installation Instructions, publication 750-IN105	Provides instructions to setup and use the PowerFlex 750-Series Service Cart and DCPC Lift. Includes spare parts for the service cart and for the high power conversion kit.
PowerFlex 750-Series Spare Parts Installation Instructions, publication 750-IN013	Provides additional information to acquire spare parts for the PowerFlex 750-Series.
EtherNet/IP Network Devices User Manual, ENET-UM006	Describes how to configure and use EtherNet/IP devices to communicate on the EtherNet/IP network.
Ethernet Reference Manual, ENET-RM002	Describes basic Ethernet concepts, infrastructure components, and infrastructure features.
System Security Design Guidelines Reference Manual, SECURE-RM001	Provides guidance on how to conduct security assessments, implement Rockwell Automation products in a secure system, harden the control system, manage user access, and dispose of equipment.
UL Standards Listing for Industrial Control Products, publication CMPNTS-SR002	Assists original equipment manufacturers (OEMs) with construction of panels, to help ensure that they conform to the requirements of Underwriters Laboratories.
American Standards, Configurations, and Ratings: Introduction to Motor Circuit Design, publication IC-AT001	Provides an overview of American motor circuit design based on methods that are outlined in the NEC.
Industrial Components Preventive Maintenance, Enclosures, and Contact Ratings Specifications, publication IC-TD002	Provides a quick reference tool for Allen-Bradley industrial automation controls and assemblies.
Safety Guidelines for the Application, Installation, and Maintenance of Solid-state Control, publication SGI-1.1	Designed to harmonize with NEMA Standards Publication No. ICS 1.1-1987 and provides general guidelines for the application, installation, and maintenance of solid-state control in the form of individual devices or packaged assemblies incorporating solid-state components.
Industrial Automation Wiring and Grounding Guidelines, publication 1770-4.1	Provides general guidelines for installing a Rockwell Automation industrial system.
Product Certifications website, rok.auto/certifications .	Provides declarations of conformity, certificates, and other certification details.

You can view or download publications at [rok.auto/literature](#).

Rockwell Automation Support

Use these resources to access support information.

Technical Support Center	Find help with how-to videos, FAQs, chat, user forums, Knowledgebase, and product notification updates.	rok.auto/support
Local Technical Support Phone Numbers	Locate the telephone number for your country.	rok.auto/phonesupport
Technical Documentation Center	Quickly access and download technical specifications, installation instructions, and user manuals.	rok.auto/techdocs
Literature Library	Find installation instructions, manuals, brochures, and technical data publications.	rok.auto/literature
Product Compatibility and Download Center (PCDC)	Download firmware, associated files (such as AOP, EDS, and DTM), and access product release notes.	rok.auto/pcdc

Documentation Feedback

Your comments help us serve your documentation needs better. If you have any suggestions on how to improve our content, complete the form at rok.auto/docfeedback.

Allen-Bradley, CENTERLINE, Compact I/O, DeviceLogix, DPI, expanding human possibility, Kinetix, PowerFlex, RDD-Series, Rockwell Automation, SCANport, and Studio 5000 Logix Designer are trademarks of Rockwell Automation, Inc.





ControlNet, DeviceNet, and EtherNet/IP are trademarks of ODVA, Inc.

Trademarks not belonging to Rockwell Automation are property of their respective companies.

Rockwell Automation maintains current product environmental compliance information on its website at rok.auto/pec.

Rockwell Automation NV Commercial Registration Number 0424.293.935

Rockwell Otomasyon Ticaret A.Ş. Kar Plaza İş Merkezi E Blok Kat:6 34752, Çerenköy, İstanbul, Tel: +90 (216) 5698400 EEE Yönetmeliğine Uygundur

Connect with us.    

rockwellautomation.com ————— expanding **human possibility**[®]

AMERICAS: Rockwell Automation, 1201 South Second Street, Milwaukee, WI 53204-2496 USA, Tel: (1) 414.382.2000, Fax: (1) 414.382.4444

EUROPE/MIDDLE EAST/AFRICA: Rockwell Automation NV, Pegasus Park, De Kleetlaan 12a, 1831 Diegem, Belgium, Tel: (32) 2 663 0600, Fax: (32) 2 663 0640

ASIA PACIFIC: Rockwell Automation, Level 14, Core F, Cyberport 3, 100 Cyberport Road, Hong Kong, Tel: (852) 2887 4788, Fax: (852) 2508 1846

UNITED KINGDOM: Rockwell Automation Ltd. Pitfield, Kiln Farm Milton Keynes, MK11 3DR, United Kingdom, Tel: (44)(1908) 838-800, Fax: (44)(1908) 261-917

Publication 750-TD001P-EN-P - July 2025

Supersedes Publication 750-TD0010-EN-P - October 2022

Copyright © 2025 Rockwell Automation, Inc. All rights reserved. Printed in the U.S.A.