



Kinetix MPL Low-inertia Servo Motor with 100 mm to 165 mm Frame Size

Catalog Numbers MPL-A310, MPL-A320, MPL-A330, MPL-A420, MPL-A430, MPL-A4530, MPL-A4540, MPL-A4560, MPL-A520, MPL-A540, MPL-A560, MPL-B310, MPL-B320, MPL-B330, MPL-B420, MPL-B430, MPL-B4530, MPL-B4540, MPL-B4560, MPL-B520, MPL-B540, MPL-B560, MPL-B580

Topic	Page
Catalog Number Explanation	3
About the Kinetix MPL Low-inertia Motors	4
Before You Begin	4
Install the Motor	7
Product Dimensions	11
Motor Load Force Ratings	15
Connector Data	16
Remove and Install a Shaft Key	18
Motor Cables and Accessory Kits	18
Specifications	19
Additional Resources	20



Summary of Changes

This publication contains the following new or updated information. This list includes substantive updates only and is not intended to reflect all changes. Translated versions are not always available for each revision.

Topic	Page
Corrected Connector Data pin F and pin K.	16
Removed IP and ATEX ratings. Replaced with a reference to KNX-TD001 .	19
Updated document links, terms, and formats.	throughout

Boilerplate Elements

North American Hazardous Location Approval

The following information applies when operating this equipment in hazardous locations.	Informations sur l'utilisation de cet équipement en environnements dangereux.	
<p>Products marked "CL I, DIV 2, GP A, B, C, D" are suitable for use in Class I Division 2 Groups A, B, C, D, Hazardous Locations and nonhazardous locations only. Each product is supplied with markings on the rating nameplate indicating the hazardous location temperature code. When combining products within a system, the most adverse temperature code (lowest "T" number) may be used to help determine the overall temperature code of the system. Combinations of equipment in your system are subject to investigation by the local Authority Having Jurisdiction at the time of installation.</p>	<p>Les produits marqués "CL I, DIV 2, GP A, B, C, D" ne conviennent qu'à une utilisation en environnements de Classe I Division 2 Groupes A, B, C, D dangereux et non dangereux. Chaque produit est livré avec des marquages sur sa plaque d'identification qui indiquent le code de température pour les environnements dangereux. Lorsque plusieurs produits sont combinés dans un système, le code de température le plus défavorable (code de température le plus faible) peut être utilisé pour déterminer le code de température global du système. Les combinaisons d'équipements dans le système sont sujettes à inspection par les autorités locales qualifiées au moment de l'installation.</p>	
	<p>WARNING: Explosion Hazard -</p> <ul style="list-style-type: none"> Do not disconnect equipment unless power has been removed or the area is known to be nonhazardous. Do not disconnect connections to this equipment unless power has been removed or the area is known to be nonhazardous. Secure any external connections that mate to this equipment by using screws, sliding latches, threaded connectors, or other means provided with this product. Substitution of components may impair suitability for Class I, Division 2. If this product contains batteries, they must only be changed in an area known to be nonhazardous. 	 <p>AVERTISSEMENT: Risque d'Explosion -</p> <ul style="list-style-type: none"> Couper le courant ou s'assurer que l'environnement est classé non dangereux avant de débrancher l'équipement. Couper le courant ou s'assurer que l'environnement est classé non dangereux avant de débrancher les connecteurs. Fixer tous les connecteurs externes reliés à cet équipement à l'aide de vis, loquets coulissants, connecteurs filetés ou autres moyens fournis avec ce produit. La substitution de composants peut rendre cet équipement inadapté à une utilisation en environnement de Classe I, Division 2. S'assurer que l'environnement est classé non dangereux avant de changer les piles.

Catalog Number Explanation

MP L - x x 10 x - x x x x A x

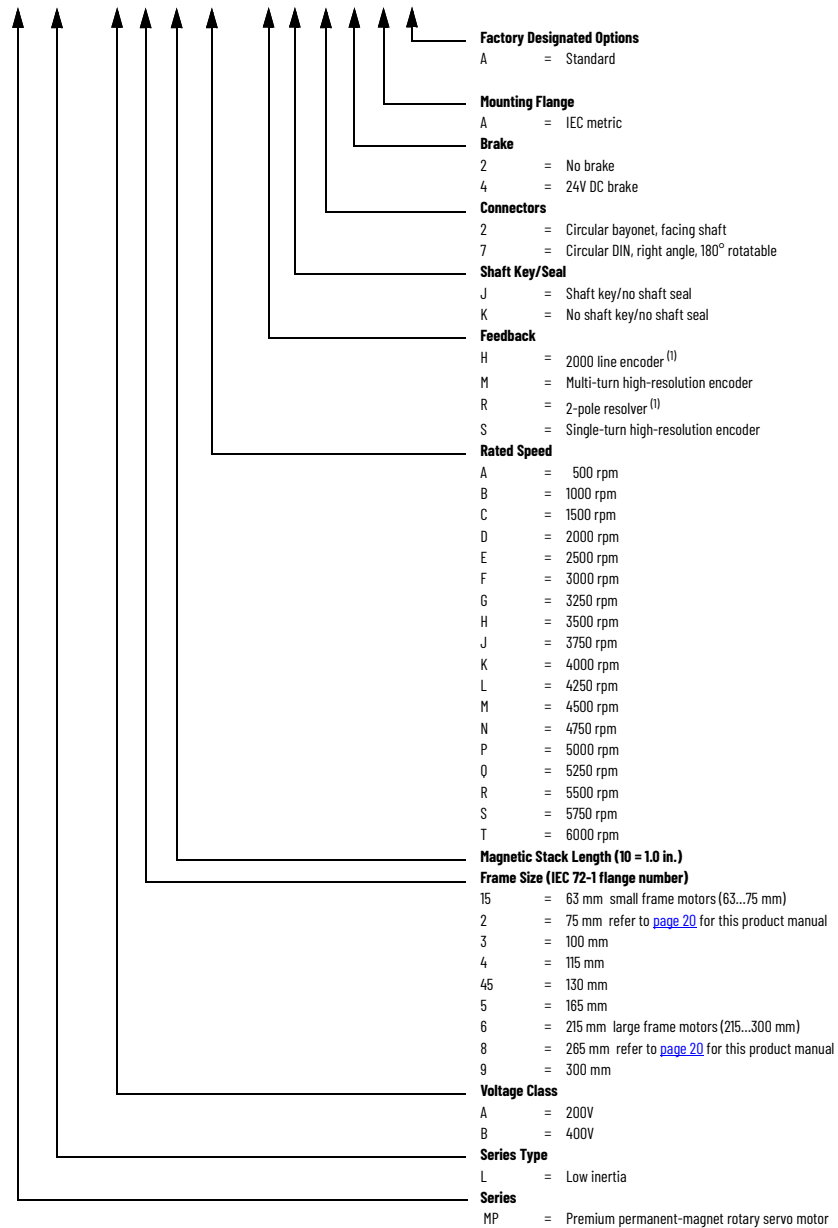

(1) Not available on catalog number MPL-x5xxx or larger (>165 mm frame sizes).

About the Kinetix MPL Low-inertia Motors

Kinetix® MPL low-inertia motors feature single-turn or multi-turn high-resolution encoders, and are available with 24V DC brakes. These compact brushless servo motors meet the demanding requirements of high-performance motion systems.

Before You Begin

Remove all packing material from within and around the item. After unpacking, verify the nameplate catalog number against the purchase order.



ATTENTION: To avoid personal injury and damage to the motor, do not lift or handle the motor by the motor shaft. The cap on the shaft can come loose and cause you to drop the motor.

1. Remove the motor carefully from its shipping container.
2. Visually inspect the motor for any damage.
3. Examine the motor frame, front output shaft, and mounting pilot for any anomalies.
4. Notify the carrier of any shipping damage immediately.

Keep the original packing material in case you must return the product for repair or transport it to another location. Use both the inner and outer packing cartons to provide adequate protection for a unit that is returned for service.



ATTENTION: Do not attempt to open and modify the motor beyond changing the connector orientation as described in [Change the Orientation of the Connectors on page 7](#).

Only an authorized Allen-Bradley repair center can service this item. See Rockwell Automation Support for assistance to locate the nearest repair center.

Store or operate your motor in a clean and dry location within the environmental conditions that are listed in [Specifications on page 19](#).

Removing the Shaft Cap

Use your hand to remove the protective cap that is installed on the motor shaft or pry off the cap with a screwdriver. Do not use a hammer or other tools as they can damage the motor shaft.

Prolonging Motor Life

Proper design and maintenance can increase the life of a servo motor. Follow these guidelines to maximize the life of a servo motor within your environment:

- Always provide a drip loop in each cable to carry liquids away from the connection to the motor.

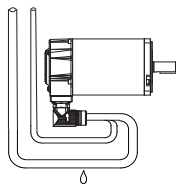

The cable enters beneath the motor and forms a drip loop.

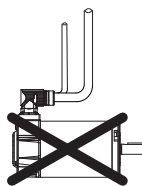

The cable enters above the motor and does not form a drip loop.

- If possible, provide shields that help protect the motor housing, shaft seals, and their junctions from contamination by foreign matter or fluids.

- Shaft seals are subject to wear and require periodic inspection and replacement. Replacement is recommended every 3 months, not to exceed 12 months, depending on use. See [Shaft Seal Kits on page 19](#) for more information on shaft seals.
- Inspect the motor and seals for damage or wear regularly. If damage or excessive wear is observed, replace the item.
- The brake option on this servo motor is a spring-set holding brake that releases when voltage is applied to the brake coil. A separate power source is required to disengage the brake. This power source is applied by a servo motor controller or manual operator control.

If system main power fails, holding brakes can withstand occasional use as stopping brakes. However, this creates rotational mechanical backlash that can damage the system, increase brake wear, and reduce brake life.

IMPORTANT

Holding brakes are not designed to stop rotation of the motor shaft, and they are not intended to be used as a safety device. They are designed to hold a motor shaft at 0 rpm for up to the rated brake holding torque.

Follow these steps to prevent motor shaft rotation.

1. Command the servo drive to 0 rpm.
2. Verify the motor is at 0 rpm.
3. Engage the brake.
4. Disable the drive.

Disabling the drive removes the potential for brake wear caused by a badly-tuned servo system oscillating the shaft.

Using Shaft Seals

An additional seal is required on the motor shaft near the motor front bearing if the shaft is exposed to fluids or significant amounts of fine dust. This includes lubricating oil from a gearbox. An IP66 rating for the motor requires the use of a shaft seal and environmentally sealed connectors/cables. The additional seal is not recommended in applications where the motor shaft area is free of liquids or fine dust, and a lower rating is sufficient:

- See [Shaft Seal Kits on page 19](#) to find the catalog numbers of seal kits available for your motor.
- See Kinetix Rotary and Linear Motion Cable Specifications Technical Data, publication [KNX-TD004](#), to find environmentally sealed connectors and cables compatible with the Kinetix MPL motors.

Using Couplings and Pulleys

Mechanical connections to the motor shaft, such as couplings and pulleys, require a torsionally rigid coupling or a reinforced timing belt. The high dynamic performance of servo motors can cause couplings, pulleys, or belts to loosen or slip over time. A loose or slipping connection can cause system instability and damage the motor shaft. All connections between the system and the servo motor shaft must be rigid to achieve acceptable response from the system. Periodically inspect connections to verify their rigidity.

When mounting couplings or pulleys to the motor shaft, be sure that the connections are properly aligned and that axial and radial loads are within the specifications of the motor. See [Motor Load Force Ratings on page 15](#) for guidelines to achieve 20,000 hours of motor bearing life.



ATTENTION: Damage can occur to the motor bearings and the feedback device if sharp impact to the shaft is applied during installation of couplings and pulleys. Damage to the feedback device can result by applying leverage from the motor mounting face to remove devices mounted on the motor shaft.

Do not strike the shaft, couplings, or pulleys with tools during installation or removal. Use a wheel puller to apply pressure from the user end of the shaft and remove any friction-fit or stuck device from the motor shaft.

Preventing Electrical Noise

Electromagnetic interference (EMI), commonly called noise, can cause poor motor performance by inducing stray signals.

Follow these guidelines to prevent the effects of EMI:

- Isolate the power transformers, or install line filters on all AC input power lines.
- Separate signal cables from motor cabling and power wiring. Do not route signal cables with motor and power wires, or over the vent openings of servo drives.
- Ground all equipment by using a single-point parallel ground system that employs ground bus bars or large straps. If necessary, use additional electrical noise reduction techniques to reduce EMI in noisy environments.

See System Design for Control of Electrical Noise Reference Manual, publication [GMC-RM001](#), for additional information on reducing the effects of EMI by improving the system level electromagnetic compatibility (EMC).

Build and Install the Cables

Correct cable routing and careful cable construction improve system electromagnetic compatibility (EMC).

Follow these guidelines to build and install the cables:

- Keep the wire lengths as short as possible.
- Route noise sensitive wiring (encoder, serial, and I/O) away from input power and motor power wiring.
- Separate cables by 0.3 m (1 ft) minimum for every 9 m (30 ft) of parallel run.
- Ground both ends of the encoder cable shield and twist the signal wire pairs to help prevent EMI from other equipment.



ATTENTION: High voltage can be present on the shield of a power cable, if the shield is not grounded. Verify that there is a connection to ground for any power cable shield.



ATTENTION: Kinetix MPL motors produce leakage current in the protective earthing conductor that exceeds 3.5 mA AC and/or 10 mA DC. Be sure to properly ground the motor cables per the drive installation instructions.

Ground Shielded Signal Wires Within a Power Cable

Always connect the shield on any signal wire pair that is routed inside a power cable to the overall machine ground.

If you are installing a 2090-XXNPMF-xxSxx or 2090-CPBM4DF-xxAFxx power with brake cable, loop the signal wire pairs to the overall cable shield as shown in [Grounding of Signal Wire Shields in a Power Cable on page 7](#). Then clamp all shields together in the power cable (chassis) ground connection on the drive.

Grounding of Signal Wire Shields in a Power Cable

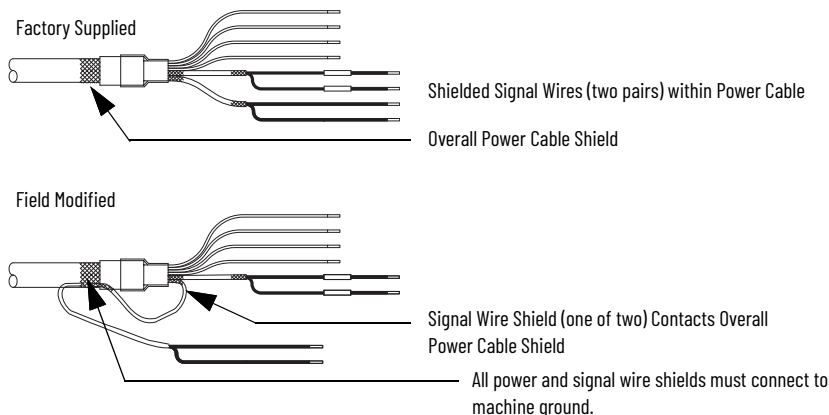

2090-XXNPMF-xxSxx (shown) contains two signal wire pairs.
2090-CPBM4DF-xxAFxx contains one signal wire pair.

The diagram shows one of the two signal wires in the correct position. Connect both signal wire shields and the overall power cable shield to machine ground.

The signal wire pairs within a power cable often carry a 24V DC brake signal, but can also carry logic signals. Grounding the shield that surrounds the signal wires dissipates an induced voltage and reduces the effects of EMI.

Install the Motor

Kinetix MPL motors include a mounting pilot for aligning the motor on the machine. Preferred fasteners are stainless steel. The installation must comply with all local regulations and use equipment and installation practices that promote safety and electromagnetic compatibility.



ATTENTION: Unmounted motors, disconnected mechanical couplings, loose shaft keys, and disconnected cables are dangerous if power is applied. Lock-out and tag-out disassembled equipment (restrict electrical power). Before applying power to the motor, remove the shaft key and other mechanical couplings that can be thrown from the shaft.



ATTENTION: Make sure that cables are installed and restrained to help prevent uneven tension or flexing at the cable connections. Excessive and uneven lateral force on the cable can inhibit environmental sealing as the cable flexes.

Change the Orientation of the Connectors

Kinetix MPL motors use two styles of connectors. The connector style is identified by a 2 or a 7 as the connector variable in the motor catalog number. For example, MPx-xxxx-xx2xxx or MPx-xxxx-xx7xxx:

- A 2 indicates a circular bayonet connector, facing the shaft.
- A 7 indicates a circular DIN, right angle, rotatable connector.

Rotatable Circular DIN Connector (catalog number MPL-xxxxx-xx7xxx)

The circular DIN connector housing can be rotated up to 180° in either direction.



ATTENTION: Connectors are designed to be rotated into a fixed position during motor installation, and remain in that position without further adjustment. Do not rotate the connector multiple times, and do not use tools or excessive force to rotate the connector. Excessive rotation or force can damage the connector seal and reduce the international protection (IP) rating of the motor as outlined in [Specifications on page 19](#).

Follow these steps to turn the DIN connectors.

1. Mount and fully seat a mating cable on the connector.
2. Grasp both connectors by their housings and slowly rotate them to the outside of the motor.

If necessary, repeat this step for each connector (feedback or power/brake).

Apply force to only the connectors; do not apply force to the cable. Do not use tools (for example, pliers and vise-grips) to rotate the connector.

Mount the Motor

Follow these steps to mount the motor.



ATTENTION: Damage can occur to the motor bearings and the feedback device if sharp impact to the shaft is applied during installation of couplings and pulleys. Do not strike the shaft, couplings, or pulleys with tools during installation or removal.

1. Provide sufficient clearance, heatsink mass, and airflow for the motor so it stays within the operating temperature range of 0...40 °C (32...104 °F).

Do not enclose the motor unless forced air is blown across the motor for cooling. Keep other heat producing devices away from the motor. Heatsink requirements are listed in a footnote to the [Specifications on page 19](#).



ATTENTION: Outer surfaces of the motor can reach high temperatures of 125 °C (257 °F) during operation. Take precautions to help prevent accidental contact with hot surfaces. Consider motor surface temperature when selecting motor mating connections and cables.

2. Verify the axial and radial shaft loads of your application do not exceed those listed in the [Motor Load Force Ratings on page 15](#).
3. Place the motor with the connector housing pointing downward.
4. Mount and align the motor.

Electronic zero (index pulse or Stegmann ABS = 0) occurs when the shaft key or dimple is aligned with the connectors.

Attach the Motor Cables

Follow these steps to attach the feedback and power/brake cables after the motor is mounted.



ATTENTION: Servo drive power must be turned off before connecting or disconnecting the cables to the motor, and if a cable is left disconnected at the motor end. Arcing or unexpected motion can occur if the feedback, power, or brake cables are connected or disconnected while power is applied to the servo drive.



ATTENTION: Be sure that cables are installed and restrained to help prevent uneven tension or flexing at the cable connectors. Provide support at 3 m (10 ft) intervals throughout the cable run. Excessive and uneven lateral force at the cable connectors can result in the connector's environmental seal opening and closing as the cable flexes, or wires separating at the cable gland.

1. If you are using the **Threaded DIN (M4) Cable Plugs**, install the O-rings.

An O-ring on the connector is necessary to achieve the maximum environmental rating.

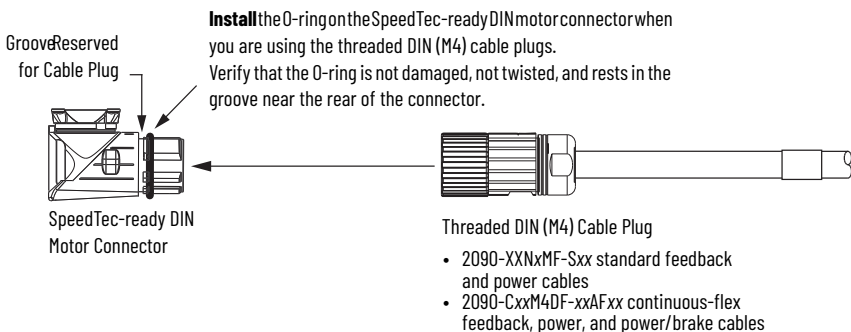

2. If you are using the **SpeedTec DIN (M7) Cable Plugs**, do not install the O-rings.

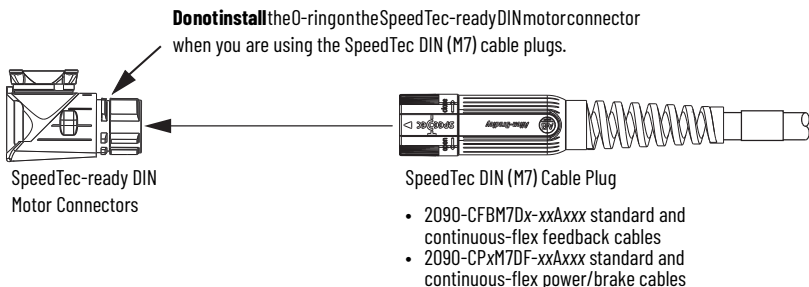

3. Form a drip loop in the cable (see [page 4](#)).
4. Carefully align the flat surface on the feedback or the power/brake cable plug (shown in the diagram) with the flat surface on the motor connector.

IMPORTANT

The motor orientation that is shown is used to show the alignment marker on each cable socket.

The recommended motor orientation when installed positions the connectors at the bottom of the motor.

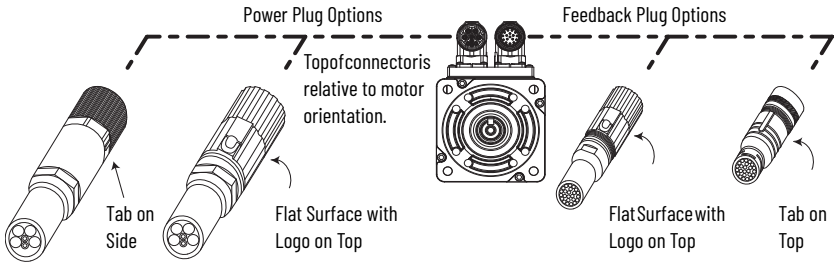

Connector plugs have either a tab or a flat surface with a logo to indicate the alignment point.

5. Hand tighten the collar on the plug to fully seat it on the connector:

- Threaded DIN (M4) cable plugs require five to six revolutions.
- SpeedTec DIN (M7) cable plugs require approximately one-quarter of a revolution.



A fully-seated threaded plug leaves a small opening, approximately 1...4 mm (0.04...0.16 in.), between the connector and the plug.

Do not apply excessive force when mating the cable plug with the motor connector. If the plug and connector do not go together with light hand force, realign the flat surfaces and try again.



ATTENTION: Align the keyed connectors and hand-tighten the recommended number of turns.

If you cannot tighten the connectors by hand, verify that the keyed connectors are properly aligned. Do not use tools (for example, pliers and vise-grips) to tighten the connectors.

Product Dimensions

This section provides approximate dimensions for the motors. Dimensions are for reference only and should not be used for manufacturing purposes.

Dimensions for Bayonet Connectors (catalog number MPL-xxxxx-xx2xxx)

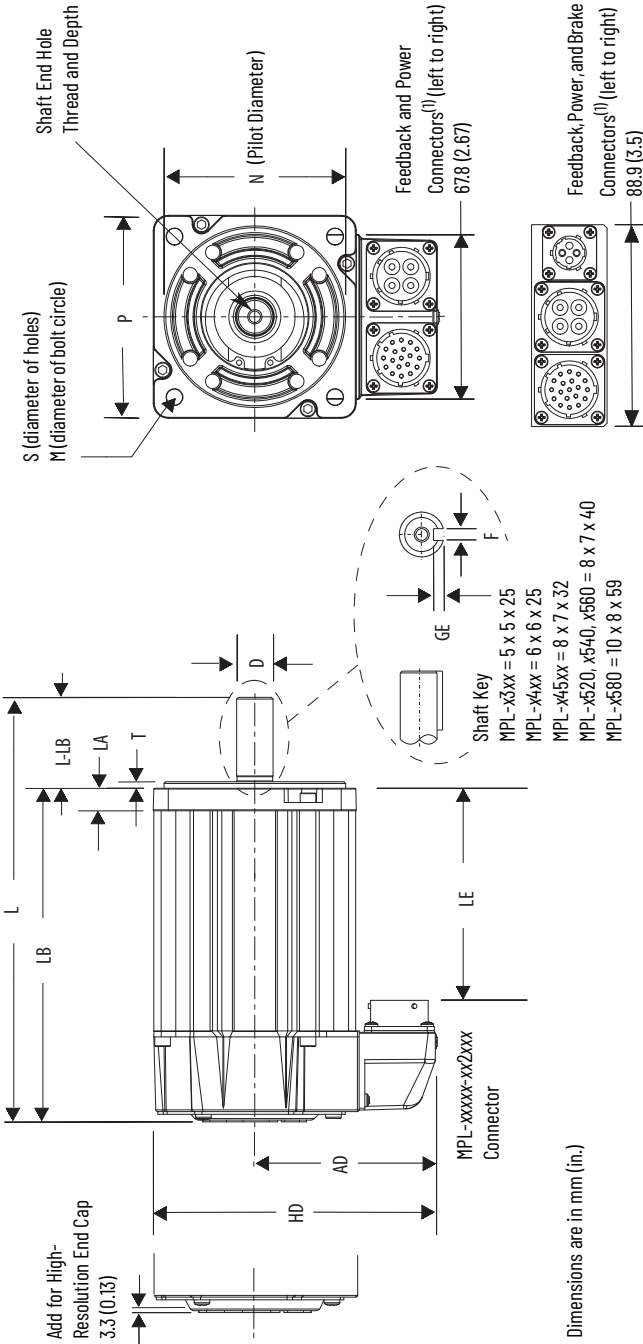

(1) Electronic zero (index pulse or Stegmann ABS = 0) occurs when the shaft key or dimple (not shown) is aligned with the connectors (as shown).

Dimensions for Bayonet Connectors (catalog number MPL-xxxxx-xx2xxx)

Motor Cat. No.	AD mm (in.)	D (1) mm (in.)	HD mm (in.)	L (2),(3) mm (in.)	L-LB (4) mm (in.)	LA mm (in.)	LB (2),(3) mm (in.)	LD (2) mm (in.)	M mm (in.)	N (1) mm (in.)	P mm (in.)	S (5) mm (in.)	T mm (in.)	F (6) mm (in.)	6E (7) mm (in.)	End of Shaft Thread and Depth of Hole
MPL-A/B30				164.7 (6.49)			124.7 (4.91)	70.7 (2.78)								
MPL-A/B320	80.9 (3.19)	16.0 (0.629)	125.7 (4.95)	190.1 (7.49)	40.0 (1.58)	9.9 (0.39)	150.1 (5.91)	96.1 (3.78)	100.0 (3.937)	80.0 (3.15)	89.4 (3.52)	7.0 (0.283)	2.87 (0.113)	5.0 (0.20)	3.0 (0.12)	M5 x 0.8-6H 12.5 (0.49)
MPL-A/B330				215.5 (8.49)			175.5 (6.91)	121.5 (4.78)								
MPL-A/B420	83.9 (3.3)	19.0 (0.748)	132.8 (5.23)	186.5 (7.35)	40.0 (1.575)	10.2 (0.40)	146.5 (5.77)	92.5 (3.64)	115.0 (4.528)	95.0 (3.74)	98.3 (3.87)	10.0 (0.401)	2.87 (0.113)	6.0 (0.24)	3.5 (0.138)	M6 x 1.0-6H 16 (0.63)
MPL-A/B430				219.9 (8.345)			171.9 (6.77)	117.9 (4.64)								
MPL-A/B4630				225.2 (8.87)			175.2 (6.90)	121.2 (4.77)								
MPL-A/B4540	91.5 (3.6)	24.0 (0.945)	148.3 (5.84)	250.6 (9.87)	50.0 (1.97)	12.2 (0.48)	200.6 (7.90)	146.6 (5.77)	130.0 (5.118)	110.0 (4.331)	113.7 (4.48)	10.0 (0.401)	3.38 (0.133)	8.0 (0.31)	4.0 (0.158)	M8 x 1.25-6H 19 (0.75)
MPL-A/B4560				304.7 (11.99)			254.7 (10.03)	197.4 (7.77)								
MPL-A/B520				233.7 (9.20)			173.7 (6.84)	115.8 (4.56)								
MPL-A/B540	106.2 (4.18)	28.0 (1.1)	178.1 (7.01)	284.5 (11.20)	60.0 (2.38)	13.97 (0.55)	224.5 (8.84)	166.9 (6.57)	165.0 (6.496)	130.0 (5.118)	143.5 (5.66)	12.0 (0.481)	3.38 (0.133)	8.0 (0.31)	4.0 (0.158)	M10 x 1.5-6H 22 (0.87)
MPL-A/B560				335.3 (13.20)			275.3 (10.84)	217.7 (8.56)								
MPL-B560 (8)		32.0 (1.26)		406.1 (15.99)	80.0 (3.15)		326.1 (12.84)	268.5 (10.57)						10.0 (0.39)	5.0 (0.197)	M12 x 1.75-6H 28 (1.10)

(1) Refer to Kinetix Rotary Motion Specifications Technical Data publication [KXX-10001](#), for tolerances on these measurements.
 (2) Motors with brake, add this value to the dimension:
 MPL-x30 through -x330: add 34.5 mm (1.36 in.) to L, LB, and LD.
 MPL-x420 through -x4560: add 48.5 mm (1.91 in.) to L, LB, and LD.
 MPL-x520 through -x560: add 51.6 mm (2.03 in.) to L and LB, and 45.6 mm (1.79 in.) to LD.
 (3) Motors with high-resolution feedback, add 3.3 mm (0.13 in.) to L and LB.
 (4) Tolerance is ±0.7 (±0.028).
 (5) x3xx and x4xx tolerance is +0.36 (±0.0007), x5xx is -0.43 (±0.008).
 (6) Tolerance is -0.03 (-0.001).
 (7) Tolerance is -0.1 (-0.004).
 (8) This motor is available only with 460V windings (catalog number MPL-B560).

Dimensions for Rotatable Circular DIN Connectors (catalog number MPL-xxxx-xx7xxx)

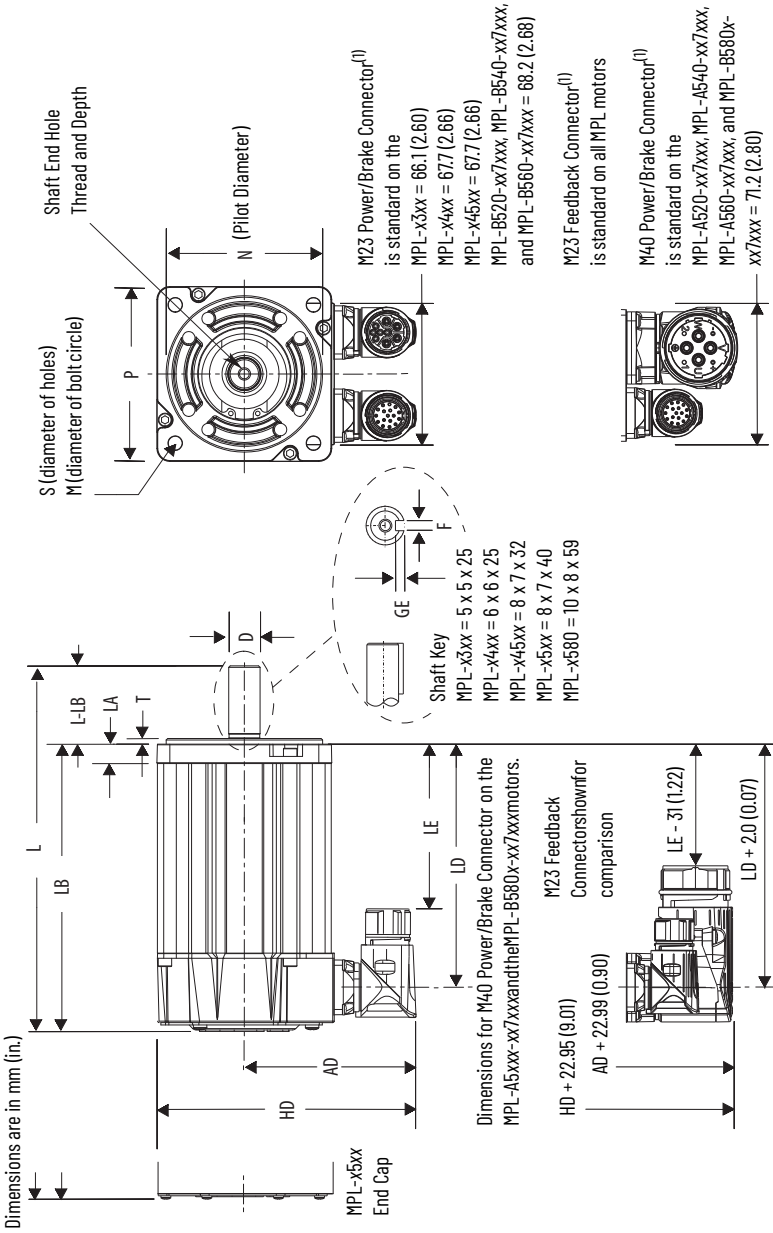

(1) Electronic zero (index pulse or Stegmann ABS = 0) occurs when the shaft key or dimple (not shown) is aligned with the connectors (as shown).

Dimensions for Rotatable Circular DIN Connectors (catalog number MPL-xxxxx-xx7xxx)

Dimensions are for reference only and should not be used for manufacturing purposes.

Motor Cat. No.	AD mm (in.)	D (1) mm (in.)	HD mm (in.)	L (2) mm (in.)	L-LB (3) mm (in.)	LA mm (in.)	LB (2) mm (in.)	LD (2) mm (in.)	LE (2) mm (in.)	M mm (in.)	N (4) mm (in.)	P mm (in.)	S (4) mm (in.)	T mm (in.)	F (5) mm (in.)	GE (6) mm (in.)	End of Shaft Thread and Depth of Hole
MPL-A/B310				168.0 (6.62)			128.0 (5.04)	102.0 (4.03)	62.0 (2.45)								
MPL-A/B320	87.2 (3.44)	16.0 (0.629)	132.0 (5.20)	78.30 (3.08)	40.0 (1.575)	9.90 (0.39)	153.0 (6.04)	728.0 (28.66)	88.0 (3.46)	100.0 (3.937)	80.0 (3.15)	89.4 (3.52)	7.0 (0.283)	2.74 (0.108)	5.0 (0.20)	3.0 (0.12)	M5 x 1.0-6H 12.5 (0.49)
MPL-A/B330				219.0 (8.62)			179.0 (7.04)	153.0 (6.03)	113.0 (4.46)								
MPL-A/B420	90.9 (3.58)	19.0 (0.748)	140.1 (5.52)	101.0 (3.94)	40.0 (1.575)	10.16 (0.40)	150.0 (5.90)	124.0 (4.88)	84.0 (3.31)	115.0 (4.528)	95.0 (3.74)	98.3 (3.87)	10.0 (0.401)	2.74 (0.108)	6.0 (0.234)	3.5 (0.138)	M6 x 1.0-6H 16 (0.63)
MPL-A/B430				215.0 (8.48)			175.0 (6.89)	150.0 (5.89)	110.0 (4.33)								
MPL-A/B4530				229.0 (9.0)			179.0 (7.03)	153.0 (6.02)	113.0 (4.44)								
MPL-A/B4540	98.6 (3.88)	24.0 (0.945)	155.4 (6.12)	101.0 (3.94)	50.0 (1.97)	12.19 (0.48)	204.0 (8.03)	178.0 (7.02)	138.0 (5.44)	130.0 (5.118)	110.0 (4.331)	113.7 (4.48)	10.0 (0.401)	2.74 (0.108)	8.0 (0.31)	4.0 (0.158)	M8 x 1.25-6H 19 (0.75)
MPL-A/B4680				305.0 (12.0)			255.0 (10.03)	229.0 (9.02)	189.0 (7.44)								
MPL-A/B520				236.0 (9.29)			176.0 (6.92)	151.0 (5.95)	80.0 (3.15)								
MPL-A/B540	136.4 (5.37)	28.0 (1.102)	208.1 (8.19)	101.0 (3.94)	80.0 (3.15)	14.0 (0.55)	227.0 (8.92)	202.0 (7.95)	131.0 (5.15)	165.0 (6.496)	130.0 (5.118)	143.5 (5.65)	12.0 (0.481)	3.12 (0.123)	8.0 (0.315)	4.0 (0.158)	M10 x 1.5-6H 22 (0.87)
MPL-A/B560				337.0 (13.28)			277.0 (10.92)	253.0 (9.95)	182.0 (7.15)								
MPL-A/B520				236.0 (9.29)			176.0 (6.92)	149.0 (5.88)	109.0 (4.30)								
MPL-A/B540	113.4 (4.47)	28.0 (1.102)	185.2 (7.29)	101.0 (3.94)	60.0 (2.362)	14.0 (0.55)	227.0 (8.92)	200.0 (7.88)	160.0 (6.30)	165.0 (6.496)	130.0 (5.118)	143.5 (5.65)	12.0 (0.481)	3.12 (0.123)	8.0 (0.315)	4.0 (0.158)	M10 x 1.5-6H 22 (0.87)
MPL-A/B560 (7)	136.4 (5.37)	32.0 (1.259)	208.1 (8.19)	101.0 (3.94)	80.0 (3.15)		277.0 (10.92)	251.0 (9.88)	210.0 (8.30)								
MPL-A/B580 (7)	136.4 (5.37)	32.0 (1.259)	208.1 (8.19)	101.0 (3.94)	80.0 (3.15)		328.0 (12.91)	304.0 (11.95)	232.0 (9.13)								

(1) Refer to Kinetix Rotary Motion Specifications Technical Data, publication [KX-1000](#), for tolerances on these measurements.
 (2) Motors with brake, add this value to the dimension:
 MPL-A/B310 through -x330, add 35.0 mm (1.37 in.) to L, LB, and LD.
 MPL-A/B320 through -x560, add 48.0 mm (1.89 in.) to L, LB, and LD.
 MPL-A/B420 through -x560, add 51.0 mm (2.03 in.) to L and LB, and LD.
 MPL-A/B580 add 45.6 mm (1.79 in.) to L and LB, and 52.0 mm (2.05 in.) to LD and LE.
 (3) Tolerance for this dimension is ±0.7 (±0.028).
 (4) xxx and yxxx tolerance is +0.36 (±0.0007), x5xx is +0.43 (±0.008).
 (5) Tolerance for this dimension is -0.03 (-0.001).
 (6) Tolerance for this dimension is -0.1 (-0.004).
 (7) MPL-B580x is available only with 460V windings.

Motor Load Force Ratings

Motors are capable of operating with a sustained shaft load. The radial and axial load force location is shown in the figure, and maximum values are in the tables.

Load Forces on Shaft

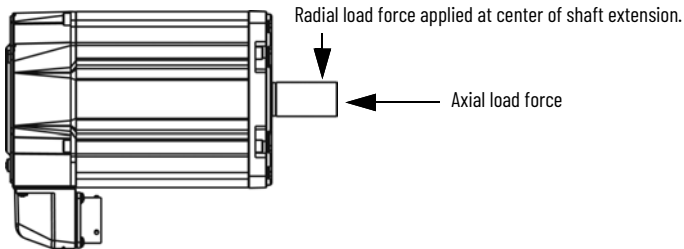

The following tables represent 20,000 hour L_{10} bearing fatigue life at various loads and speeds. This 20,000 hour life does not account for possible application-specific life reduction that can occur due to bearing grease contamination from external sources.

Radial Load Force Ratings

Motor Cat. No.	500 rpm		1000 rpm		2000 rpm		3000 rpm		3500 rpm		4000 rpm		5000 rpm	
	kg	(lb)	kg	(lb)	kg	(lb)	kg	(lb)	kg	(lb)	kg	(lb)	kg	(lb)
MPL-A/B4560	151	(332)	119	(263)	95	(209)	83	(183)	—	—	—	—	—	—
MPL-A/B520	—	—	127	(280)	100	(222)	88	(194)	—	—	80	(176)	—	—
MPL-A/B540	—	—	143	(316)	114	(251)	99	(219)	—	—	90	(199)	—	—
MPL-A/B560	—	—	153	(338)	121	(268)	106	(234)	—	—	—	—	—	—
MPL-B580	—	—	153	(338)	121	(268)	106	(234)	—	—	—	—	—	—

Axial Load Force Ratings (maximum radial load)

Motor Cat. No.	500 rpm		1000 rpm		2000 rpm		3000 rpm		3500 rpm		4000 rpm		5000 rpm	
	kg	(lb)	kg	(lb)	kg	(lb)	kg	(lb)	kg	(lb)	kg	(lb)	kg	(lb)
MPL-A/B4560	53	(117)	40	(88)	30	(65)	24	(53)	—	—	—	—	—	—
MPL-A/B520	—	—	42	(94)	30	(68)	26	(58)	—	—	22	(50)	—	—
MPL-A/B540	—	—	48	(107)	35	(79)	30	(66)	—	—	26	(58)	—	—
MPL-A/B560	—	—	52	(115)	43	(95)	32	(71)	—	—	—	—	—	—
MPL-B580	—	—	52	(115)	43	(95)	32	(71)	—	—	—	—	—	—

Axial Load Force Ratings (zero radial load)

Motor Cat. No.	500 rpm		1000 rpm		2000 rpm		3000 rpm		3500 rpm		4000 rpm		5000 rpm	
	kg	(lb)	kg	(lb)	kg	(lb)	kg	(lb)	kg	(lb)	kg	(lb)	kg	(lb)
MPL-A/B4560	69	(152)	51	(112)	38	(83)	31	(69)	—	—	—	—	—	—
MPL-A/B520	—	—	67	(149)	49	(109)	41	(92)	—	—	36	(81)	—	—
MPL-A/B540	—	—	67	(149)	49	(109)	41	(92)	—	—	36	(81)	—	—
MPL-A/B560	—	—	67	(149)	49	(109)	41	(92)	—	—	—	—	—	—
MPL-B580	—	—	67	(149)	49	(109)	41	(92)	—	—	—	—	—	—

Connector Data

These tables provide the signal descriptions for the feedback, power, and brake pinouts on the connectors.

MPL-xxxx-xx2xxx Connector Pin Descriptions

Feedback Connector				
Pin	2000-line Encoder	2-pole Resolver	High-Resolution Encoder for:	
			MPL-A3xx Through MPL-A45xx	MPL-A5xx, and all MPL-B (460V)
A	AM+	S2	SIN+	SIN+
B	AM-	S4	SIN-	SIN-
C	BM+	S1	COS+	COS+
D	BM-	S3	COS-	COS-
E	IM+	Reserved	DATA+	DATA+
F	IM-		DATA-	DATA-
G	Ground	R1	Reserved	Reserved
H	ABS	R2		
J	Reserved	Reserved	+5V DC	Reserved
K	EPWR_5V		Common	
L	ECOM		Reserved	
M	Reserved	Reserved	Reserved	Common
N				
P				
R	TS+	TS+	TS+	TS+
S	TS-	TS-	TS-	TS-
T	S1	Reserved	Reserved	Reserved
U	S2			
V	S3			

Power Connector	
Pin	Signal
A	Phase U
B	Phase V
C	Phase W
D	Ground

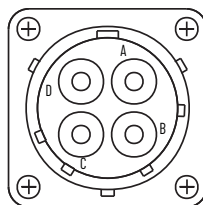

ITT Cannon
TNM 16-4 192993-0106

Brake Connector	
Pin	Signal
A	MBRK+
B	Reserved
C	MBRK-
D	Reserved

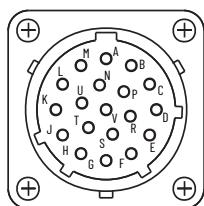

ITT Cannon
TNM 16-19 192993-0110

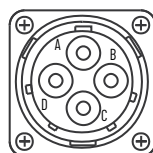

ITT Cannon
TNM 10-4 192993-0116



ATTENTION: To avoid damage to components, determine which power supply your high-resolution encoder requires and connect either the 5V or 9V supply, but not both.

MPL-xxxx-xx7xxxx Pin Descriptions

Pin	High-Resolution Encoder MPL-A3xx to MPL-A45xx (230V)	High-Resolution Encoder MPL-A5xx (230V) and MPL-Bxx (460V)	Incremental Encoder MPL-A/Bxxxx-Hxxxx
1	SIN+	SIN+	AM+
2	SIN-	SIN-	AM-
3	COS+	COS+	BM+
4	COS-	COS-	BM-
5	DATA+	DATA+	IM+
6	DATA-	DATA-	IM-
7	Reserved	Reserved	Reserved
8			Reserved
9			EPWR_5V
10	ECOM		ECOM
11	Reserved	EPWR_9V	Reserved
12		ECOM	
13	TS+	TS+	TS+
14	TS-	TS-	TS-
15	Reserved	Reserved	S1
16			S2
17			S3

Pin	Power/Brake Connector MPL-Axxx and MPL-Bxxx
A	Phase U ⁽¹⁾
B	Phase V ⁽¹⁾
C	Phase W ⁽¹⁾
D	Ground ⁽¹⁾
E	Reserved ⁽¹⁾
F	MBRK+ ⁽¹⁾
G	MBRK- ⁽¹⁾
H	Reserved ⁽¹⁾
L ⁽²⁾	

M23 Power/Brake Connector

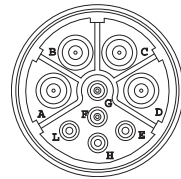

M40 Power/Brake Connector

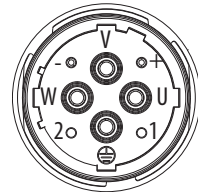

M23 Feedback Connector

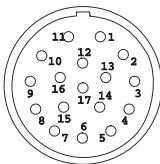

- (1) Power pins A, B, C, and D can also be labeled as U, V, W, and GND respectively. Brake pins F and G brake can also be labeled as + and - respectively. Reserved pins E and H can also be numbered 1 or 2.
- (2) M23 (BEDC...) connector has nine pins, and the M40 (CEDE...) connector has eight pins.



ATTENTION: To avoid damage to components, determine which power supply your high-resolution encoder requires and connect either the 5V or 9V supply, but not both.

Remove and Install a Shaft Key

Shaft keys are constructed of steel. The specified tolerance provides an interference fit (slightly larger than the opening) for a secure and rigid connection.



ATTENTION: Do not strike the motor's shaft, couplings, or pulleys with tools during installation or removal of the shaft key. Damage can occur to the motor bearings and the feedback device if a sharp impact is applied to the shaft during installation of couplings and pulleys, or to remove the shaft key, or if leverage is applied from the motor mounting face to remove devices that are mounted on the motor shaft.

Apply a constant pressure, with a wheel puller, to the user end of the shaft to remove a friction fit or stuck device.

To remove a shaft key, perform one of these actions:

- Lift the key by grasping it with a pliers or similar tool.
- Lever the key with a screwdriver that is inserted between the key and the slot.

To install a shaft key, follow these steps.

1. Verify that the replacement key matches the keyway in the shaft and the mating mechanical connection (for example, a coupling or pulley) before proceeding.
2. Align the front of the key with the front of the motor shaft.
This helps prevent the radiused end-of-cut at the motor end of the keyway from interfering with correct seating of the key.

Support the underside of the shaft diameter with a fixture, and use a controlled press device to apply a constant force across the top surface to press the key into the shaft.

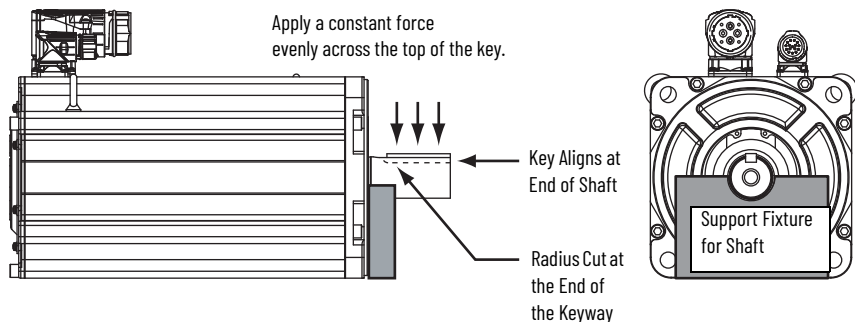

Motor Cables and Accessory Kits

This section describes accessories that are available for Kinetix MPL low-inertia motors.

Motor Cables

Factory manufactured feedback and power cables are available in standard cable lengths. They provide the sealing that is needed to achieve environmental ratings and shield termination.

If you choose to build your own cables, connector kits available for Kinetix MPL small frame motors are described in the Kinetix Rotary and Linear Motion Cable Specifications Technical Data, publication [KNX-1D004](#).

Shaft Seal Kits

IMPORTANT Shaft seals must be lubricated. Lubricant is supplied with the shaft seal kits. Third-party shaft seals are not approved for use with these motors. The use of third-party shaft seals voids any implied or expressed warranties.

A shaft seal is a barrier that can help prevent moisture and particles from entering the motor bearings.

Shaft seals are subject to wear and require periodic inspection and replacement. Replacement is recommended every 3 months, not to exceed 12 months, depending on use.

Catalog numbers for the motors and corresponding replacement Nitrile-shaft-seal kits are listed in the table.

Motor Cat. No.	Shaft Seal Kit Cat. No.
MPL-A310, MPL-B310	MPL-SSN-A3B3
MPL-A320, MPL-B320	
MPL-A330, MPL-B330	
MPL-A420, MPL-B420	MPL-SSN-A4B4
MPL-A430, MPL-B430	
MPL-A4520, MPL-B4520	MPL-SSN-A5B5
MPL-A4530, MPL-B4530	
MPL-A4540, MPL-B4540	
MPL-A4560, MPL-B4560	MPL-SSN-F165
MPL-A520, MPL-B520, MPL-A540, MPL-B540, MPL-A560, MPL-B560	
MPL-B580	MPL-SSN-F165-32MM

For instructions on how to install a shaft seal, refer to the Shaft Seal Kit Installation Instructions, publication [2090-IN012](#).

Specifications

Attribute	Value
Temperature, operating	0...40 °C (32...104 °F) ⁽¹⁾
Temperature, storage	-30...+70 °C (-22...+158 °F)
Relative humidity, storage	5...95% noncondensing
Atmosphere, storage	Noncorrosive
IP Ratings	See Kinetix Rotary Motion Specifications, publication KNX-TD001

(1) To obtain the specified motor thermal rating, mount the motor on a surface with heat dissipation equivalent to a 304.8 x 304.8 x 12.7 mm (12 x 12 x 0.5 in) aluminum heatsink.

See the Kinetix Rotary and Linear Motion Cable Specifications Technical Data, publication [KNX-TD004](#), for connector kit catalog numbers.

Additional Resources

These documents contain additional information concerning related products from Rockwell Automation. You can view or download publications at rok.auto/literature.

Resource	Description
Kinetix 5500 Servo Drives User Manual, publication 2198-UM001	Provides information on installing, configuring, startup, troubleshooting, and applications for your Kinetix servo drive system.
Kinetix 5700 Servo Drives User Manual, publication 2198-UM002	
Kinetix 6200 and Kinetix 6500 Modular Servo Drives User Manual, publication 2094-UM002	
Kinetix 6000 Multi-axis Servo Drive User Manual, publication 2094-UM001	
Kinetix 300 EtherNet/IP Indexing Servo Drives User Manual, publication 2097-UM001	
Kinetix 350 Single-axis EtherNet/IP Servo Drives User Manual, publication 2097-UM002	
Kinetix 5500 Drive System Design Guide, publication KNX-RM009	Information on drive system components and accessory items you need for your Kinetix drive/motor combination.
Kinetix 5700 Drive System Design Guide, publication KNX-RM010	
Kinetix Motion Control Selection Guide, publication KNX-SG001	Provides an overview of Kinetix servo drives, motors, actuators, and motion accessories designed to help make initial decisions for the motion control products best suited for your system requirements.
Kinetix Rotary Motion Specifications Technical Data, publication KNX-TD001	Provides product specifications for Kinetix VPL, VPC, VPF, VPH, VPS, Kinetix MPL, MPM, MPF, MPS; Kinetix TL and TLY, Kinetix RDB, Kinetix MMA, and Kinetix HPK rotary motors.
Kinetix Rotary and Linear Motion Cable Specifications, publication KNX-TD004	Product specifications for Kinetix 2090 motor and interface cables
Shaft-seal Kit Installation Instructions, publication 2090-IN012	Information on the installation of a shaft seal on this and other servo motors.
Allen-Bradley Industrial Automation Glossary, publication AG-71	A glossary of industrial automation terms and abbreviations.
System Design for Control of Electrical Noise Reference Manual, publication GMC-RM001	How to minimize and control system-level noise.
Rockwell Automation Product Certification website rok.auto/certifications	Provides declarations of conformity, certificates, and other certification details

Notes:

Rockwell Automation Support

Use these resources to access support information.

Technical Support Center	Find help with how-to videos, FAQs, chat, user forums, Knowledgebase, and product notification updates.	rok.auto/support
Local Technical Support Phone Numbers	Locate the telephone number for your country.	rok.auto/phonesupport
Technical Documentation Center	Quickly access and download technical specifications, installation instructions, and user manuals.	rok.auto/techdocs
Literature Library	Find installation instructions, manuals, brochures, and technical data publications.	rok.auto/literature
Product Compatibility and Download Center (PCDC)	Download firmware, associated files (such as AOP, EDS, and DTM), and access product release notes.	rok.auto/pcdc

Documentation Feedback

Your comments help us serve your documentation needs better. If you have any suggestions on how to improve our content, complete the form at rok.auto/docfeedback.





Waste Electrical and Electronic Equipment (WEEE)



At the end of life, this equipment should be collected separately from any unsorted municipal waste.

Rockwell Automation maintains current product environmental compliance information on its website at rok.auto/pec.

Rockwell Otomasyon Ticaret A.Ş. Kar Plaza İş Merkezi E Blok Kat:6 34752, İçerenköy, İstanbul, Tel: +90 (216) 5698400 EEE Yönetmeliğine Uygundur

Connect with us.    

rockwellautomation.com — expanding human possibility™

AMERICAS: Rockwell Automation, 1201 South Second Street, Milwaukee, WI 53204-2496 USA, Tel: (1) 414.382.2000

EUROPE/MIDDLE EAST/AFRICA: Rockwell Automation NV, Pegasus Park, De Kleetlaan 12a, 1831 Diegem, Belgium, Tel: (32) 2663 0600

ASIA PACIFIC: Rockwell Automation SEA Pte Ltd, 2 Corporation Road, #04-05, Main Lobby, Corporation Place, Singapore 618494, Tel: (65) 6510 6608

UNITED KINGDOM: Rockwell Automation Ltd., Pitfield, Kiln Farm, Milton Keynes, MK11 3DR, United Kingdom, Tel: (44)(1908) 838-800

Allen-Bradley, expanding human possibility, Kinetix, Rockwell Automation, and Rockwell Software are trademarks of Rockwell Automation, Inc. Trademarks not belonging to Rockwell Automation are property of their respective companies.