



DSI External Communications Kit

These instructions, provided with the DSI External Comms Kit, explain how to install a compatible communications adapter (sold separately) into the kit, mount the kit enclosure, and make the required electrical connections.

These instructions also describe the accessory AC Power Adapter. See [AC Power Adapter \(20-XCOMM-AC-PS1\) on page 4](#) for details.

External Comms Kit (22-XCOMM-DC-BASE)

Compatibility

This kit is for use with only the following Allen-Bradley communication adapters (sold separately):

- 22-COMM-C ControlNet
- 22-COMM-L LonWorks⁽¹⁾
- 22-COMM-D DeviceNet
- 22-COMM-P Profibus⁽²⁾
- 22-COMM-E EtherNet/IP
- 22-COMM-B BACnet MS/TP

- ⁽¹⁾ This adapter will operate in the DSI External Comms Kit, but is not compatible with a PowerFlex 4M drive.
- ⁽²⁾ The 22-COMM-P has different configuration requirements. See the 22-COMM-P User Manual (publication 22COMM-UM005) for details.

The DSI External Comms Kit is typically used to provide a network connection for PowerFlex 4 and PowerFlex 4M drives which cannot accommodate an internally-mounted adapter. Up to 5 drives can be connected via their RS-485 ports to the 22-XCOMM-DC-BASE Comms Kit.

Installing the Communications Adapter



ATTENTION: Risk of equipment damage exists. The communications adapter contains ESD (Electrostatic Discharge) sensitive parts that can be damaged if you do not follow ESD control procedures. Static control precautions are required when handling the adapter. If you are unfamiliar with static control procedures, refer to *Guarding Against Electrostatic Damage*, publication 8000-4.5.2.

1. Before you install the communication adapter into the Comms Kit, make sure to configure all of the adapter's switches and jumpers, if applicable, to appropriate settings. Refer to the Communication Adapter User Manual for details.
2. Remove the Comms Kit enclosure cover from the base by unfastening its two screws.

3. Fasten the communication adapter into the enclosure cover by using the adapter's captive screw, which also grounds the adapter, and the three screws provided with the Comms Kit ([Figure 1](#)).
4. The communication adapter is supplied with a 15.24 cm (6 in.) long Internal Interface (ribbon) cable. Plug one end of this cable into the mating connector on the power supply board in the base of the Comms Kit enclosure.

Figure 1 Mounting and Connecting the Adapter

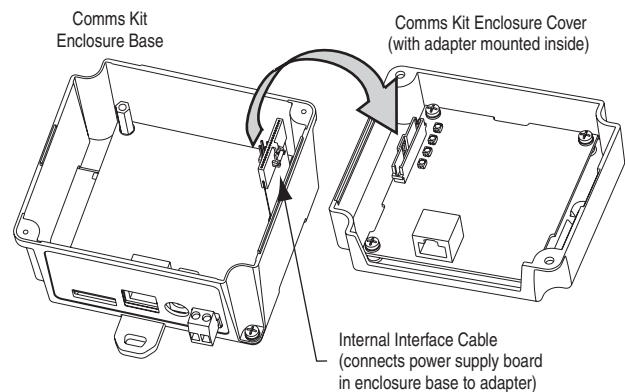

5. Plug the other end of the Internal Interface cable into the mating connector on the communication adapter.
6. Fasten the enclosure cover onto the base using the two screws in the cover.

Mounting the External Comms Kit



ATTENTION: Risk of equipment damage exists. During panel or DIN rail mounting, be sure to prevent any debris (metal chips, wire strands, etc.) from falling into the Comms Kit. Debris that falls into the kit could cause damage on power up.

Panel or DIN rail mount the Comms Kit before connecting the adapter to the network and drive.

Minimum Spacing

External Comms Kits can be zero-stacked (side-by-side mounting). Allow 75 mm (2.95 in.) of space on the bottom of the enclosure for cable entry. Allow at least 75 mm (2.95 in.) of enclosure clearance depth to accommodate the Comms Kit.

Panel Mounting Using the Dimensional Drawing

Mount the Comms Kit to a panel using two M4 or #8 panhead screws (not included). [Figure 2](#) shows mounting dimensions.

Figure 2 Panel Mounting Dimensions

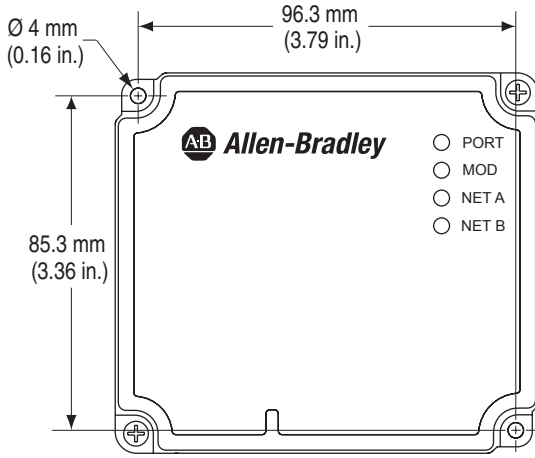

Panel Mounting Procedure Using Comms Kit as a Template

The following procedure enables you to use the assembled Comms Kit as a template for drilling holes in the panel.

1. Using the assembled Comms Kit as a template, carefully mark the center of both holes on the panel.
2. Remove the Comms Kit to a clean location.
3. Drill and tap the mounting holes for the recommended M4 or #8 panhead screws (not included).
4. Place the Comms Kit back on the panel, and check for proper hole alignment.
5. Attach the Comms Kit to the panel using the mounting screws.

DIN Rail Mounting

The Comms Kit can be mounted using these DIN rails:

- 35 x 7.5 mm (EN 50 022 - 35 x 7.5)
- 35 x 15 mm (EN 50 022 - 35 x 15)

Before mounting the Comms Kit on a DIN rail, open the DIN rail latch. Press the DIN rail mounting area of the Comms Kit against the DIN rail, and manually lock the DIN rail latch ([Figure 3](#)).

Figure 3 DIN Rail Mounting

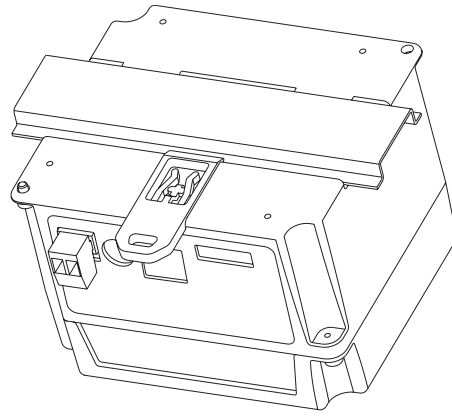

Electrical Connections



ATTENTION: Risk of equipment damage, injury or death exists. Unpredictable operation may occur if you fail to verify that parameter settings and switch settings are compatible with your application. Verify that settings are compatible with your application before applying power to the drive.

After the communication adapter is installed and the Comms Kit is mounted, make all required electrical connections. See [Figure 4](#) and its related table showing the connectors and their connection procedures.

Figure 4 Connecting to the Comms Kit

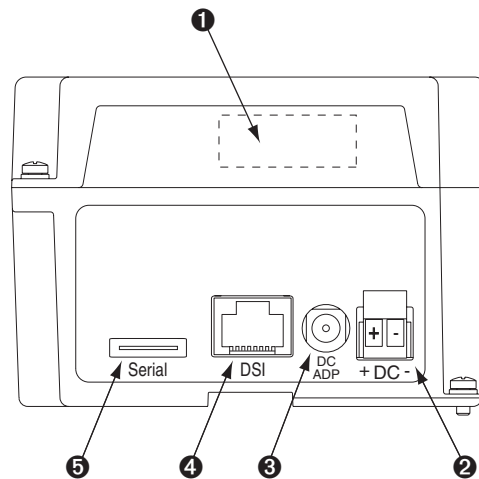

Item	Description	Connection Procedure
1	Network Connector	Connection for the network. Insert the network cable plug into the mating connector on the communications adapter.

Item	Description	Connection Procedure
②	24V DC Power Terminal Block ⁽¹⁾	<p>Connection for 24V DC (+15% / -25%) power source. Connect the “+” and “-” wires of the DC power source to the 2-pin linear plug (provided with Comms Kit), matching the respective polarity. Then insert the 2-pin linear plug into the mating DC power terminal block.</p> <p>NOTE: When powering the Comms Kit with the accessory 20-XCOMM-AC-PS1 power adapter, this terminal block can be used to daisy-chain 24V DC to other kits (Figure 5).</p>
③	AC-to-DC Adapter Connector ⁽¹⁾⁽²⁾	<p>Connection for AC-to-DC adapter, such as Allen-Bradley 20-XCOMM-AC-PS1, when not using a DC power source. Plug the adapter into the mating DC ADP connector.</p> 
④	DSI Connector	<p>Connection for DSI. Using a 22-RJ45CBL-Cxx Communications Cable or AK-U0-RJ45-TB2P Terminal Block Adapter and appropriate twisted pair cable, connect one end into the mating DSI connector of the Comms Kit and the other end into the RJ45 port on the bottom of the drive.</p> <p>Important: Always make this connection before configuring the adapter. Also, always set the connected drive's parameter A103 - [Comm Data Rate] to “4” (19.2 K).</p>
⑤	RS232 DF1 Port	<p>Connection for PC to use software tools. Using a 1203-SFC cable, connect one end into the mating Serial connector of the Comms Kit and the other end into a PC COM port.</p> <p>Important: Always make this connection before configuring the adapter. Also, when establishing communication between the computer and this port always set the baud rate to “19.2 K.”</p> <p>NOTE: This port is not functional on a 22-COMM-L or 22-COMM-P adapter.</p>

⁽¹⁾ The DC power source or AC-to-DC converter used to power the Comms Kit must be capable of providing a minimum of 150 mA @ 18...27V DC. Also, its connector must be of “pin and barrel” construction with a 2mm pin.

⁽²⁾ To power additional Comms Kits, see [Powering Daisy-Chain Comms Kits on page 4](#).

Configuring the Communications Adapter

After mounting and connecting the Comms Kit, configure the communication adapter. Refer to the Communication Adapter User Manual for complete details.

External Comms Kit Specifications

Communications

Network	Dependent on installed 22-COMM-* adapter
Drive Protocol Data Rate	DSI 19.2 kbps

Electrical

Drive	60 mA at 12V DC supplied from drive via DSI cable
Network	None for all network protocols except: DeviceNet 60 mA at 24V DC
DC Power Supply Requirement ⁽¹⁾	22-COMM-B 75 mA at 24V DC 22-COMM-C 110 mA at 24V DC 22-COMM-D 60 mA at 24V DC 22-COMM-E 140 mA at 24V DC 22-COMM-L 60 mA at 24V DC 22-COMM-P 60 mA at 24V DC

⁽¹⁾ Since the Comms Kit is powered by a nominal 24V DC, the current consumption listed in this table differs from the value shown on the label of the communication adapter, which is based on the adapter being powered by 5V DC from the drive.

Mechanical

Dimensions	
Width	108 mm (4.25 in.)
Height	108 mm (4.25 in.) with terminal connector attached
Depth	75 mm (2.95 in.)
Weight	340 g (12 oz.)

Environmental

Temperature	
Operating	-10...50°C (14...122°F)
Storage	-40...85°C (-40...185°F)
Relative Humidity	5...95% non-condensing
Atmosphere	Important: The Comms Kit must not be installed in an area where the ambient atmosphere contains volatile or corrosive gas, vapors or dust. If the Comms Kit is not going to be installed for a period of time, it must be stored in an area where it will not be exposed to a corrosive atmosphere.
Shock	
Operational	30g, 11 ms (DIN Rail Mount) 50g, 11 ms (Panel Mount)
Non-operational	30g, 11 ms (DIN Rail Mount) 50g, 11 ms (Panel Mount)
Vibration	
Operational	2.5g, 5...2000 Hz
Non-operational	5.0g, 5...2000 Hz

Regulatory Compliance

UL	UL508C
cUL	CAN / CSA C22.2 No. 14-M91
CE	EN50178 and EN61800-3
CTick	EN61800-3

NOTE: This is a product of category C2 according to IEC 61800-3. In a domestic environment this product may cause radio interference in which case supplementary mitigation measures may be required.

AC Power Adapter (20-XCOMM-AC-PS1)

The 20-XCOMM-AC-PS1 is an accessory AC-to-DC converter for use with the External Comms Kits. It is used when only 100...240V AC power is available inside a control panel. The converter, which comes with interchangeable plugs, is shown below. The converter connects to an AC receptacle inside the control panel. Use the appropriate plug for your region:

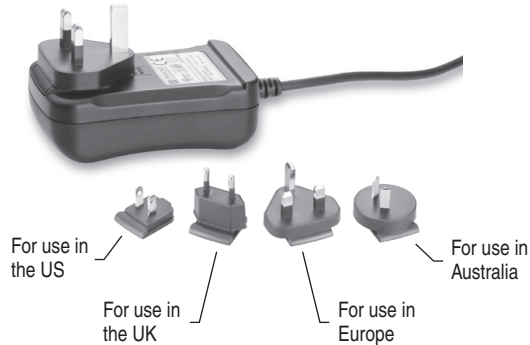

AC Power Adapter Specifications

Input	
Rated Input Voltage	100...240V AC
Operating Input Voltage	90...264V AC
AC Input Frequency	47...63 Hz
Output	
Output Voltage	24V DC
Output Current	830 mA

Electrical Connections

Powering a Single Comms Kit

The DC output plug is connected to the mating **DC ADP** connector on the 22-XCOMM-DC-BASE.

Powering Daisy-Chained Comms Kits

Additional Comms Kits can be powered by daisy-chaining them together. For each Comms Kit in the chain, connect all DC “+” terminals together and all DC “-” terminals together ([Figure 5](#)).

► **TIP:** It is highly recommended to use twisted wire pairs for better noise immunity.

Figure 5 Powering Multiple Comms Kits via Daisy Chaining

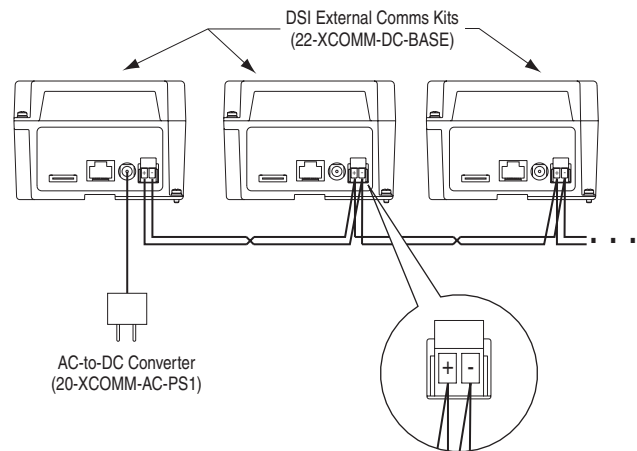

The number of Comms Kits that can be daisy-chained together is dependent on:

- Total current consumed by all of the communication adapters being daisy-chained. For adapter current consumptions at 24V DC, see [DC Power Supply Requirement on page 3](#).
- Available current output capacity of the AC-to-DC converter being used.

The following example explains how to determine the number of daisy-chained Comms Kits that can be powered:

Example: Suppose the Comms Kits being daisy-chained each have an installed 22-COMM-D DeviceNet adapter, and that the kits will be powered by the 20-XCOMM-AC-PS1 converter which has an output capacity of 830 mA.

Since the current consumed by one Comms Kit is 60 mA, divide the power source’s available output capacity by this consumption ($830 \text{ mA} \div 60 \text{ mA} = 13.83$), and round down the result. For this example, up to 13 daisy-chained Comms Kits can be powered.

U.S. Allen-Bradley Drives Technical Support - Tel: (1) 262.512.8176, Fax: (1) 262.512.2222, Email: support@drives.ra.rockwell.com, Online: www.ab.com/support/abdrives

www.rockwellautomation.com

Power, Control and Information Solutions Headquarters

Americas: Rockwell Automation, 1201 South Second Street, Milwaukee, WI 53204-2496 USA, Tel: (1) 414.382.2000, Fax: (1) 414.382.4444

Europe/Middle East/Africa: Rockwell Automation, Pegasus Park, De Kleetlaan 12a, 1831 Diegem, Belgium, Tel: (32) 2 663 0600, Fax: (32) 2 663 0640

Asia Pacific: Rockwell Automation, Level 14, Core F, Cyberport 3, 100 Cyberport Road, Hong Kong, Tel: (852) 2887 4788, Fax: (852) 2508 1846

Publication 22COMM-IN001E-EN-P – February, 2011
Supersedes 22COMM-IN001D-EN-P – July 2007

PN-105040
Copyright © 2011 Rockwell Automation, Inc. All rights reserved. Printed in USA.