



PowerFlex 40 Adjustable Frequency AC Drive

Bulletin Number 22B

Firmware Revision 1.xx...7.xx



Allen-Bradley

by ROCKWELL AUTOMATION

User Manual

Original Instructions

Important User Information

Read this document and the documents listed in the additional resources section about installation, configuration, and operation of this equipment before you install, configure, operate, or maintain this product. Users are required to familiarize themselves with installation and wiring instructions in addition to requirements of all applicable codes, laws, and standards.

Activities including installation, adjustments, putting into service, use, assembly, disassembly, and maintenance are required to be carried out by suitably trained personnel in accordance with applicable code of practice.

If this equipment is used in a manner not specified by the manufacturer, the protection provided by the equipment may be impaired.

In no event will Rockwell Automation, Inc. be responsible or liable for indirect or consequential damages resulting from the use or application of this equipment.

The examples and diagrams in this manual are included solely for illustrative purposes. Because of the many variables and requirements associated with any particular installation, Rockwell Automation, Inc. cannot assume responsibility or liability for actual use based on the examples and diagrams.

No patent liability is assumed by Rockwell Automation, Inc. with respect to use of information, circuits, equipment, or software described in this manual.

Reproduction of the contents of this manual, in whole or in part, without written permission of Rockwell Automation, Inc., is prohibited.

Throughout this manual, when necessary, we use notes to make you aware of safety considerations.



WARNING: Identifies information about practices or circumstances that can cause an explosion in a hazardous environment, which may lead to personal injury or death, property damage, or economic loss.



ATTENTION: Identifies information about practices or circumstances that can lead to personal injury or death, property damage, or economic loss. Attentions help you identify a hazard, avoid a hazard, and recognize the consequence.

IMPORTANT

Identifies information that is critical for successful application and understanding of the product.

These labels may also be on or inside the equipment to provide specific precautions.



SHOCK HAZARD: Labels may be on or inside the equipment, for example, a drive or motor, to alert people that dangerous voltage may be present.



BURN HAZARD: Labels may be on or inside the equipment, for example, a drive or motor, to alert people that surfaces may reach dangerous temperatures.



ARC FLASH HAZARD: Labels may be on or inside the equipment, for example, a motor control center, to alert people to potential Arc Flash. Arc Flash will cause severe injury or death. Wear proper Personal Protective Equipment (PPE). Follow ALL Regulatory requirements for safe work practices and for Personal Protective Equipment (PPE).

The following icon may appear in the text of this document.



Identifies information that is useful and can help to make a process easier to do or easier to understand.

Rockwell Automation recognizes that some of the terms that are currently used in our industry and in this publication are not in alignment with the movement toward inclusive language in technology. We are proactively collaborating with industry peers to find alternatives to such terms and making changes to our products and content. Please excuse the use of such terms in our content while we implement these changes.

Summary of Changes

Manual Updates

The information below summarizes the changes made for the October 2024 PowerFlex® 40 Adjustable Frequency AC Drive User Manual, publication 22B-UM001J-EN-E.

Description of New or Updated Information	See Pages
Updated front and back cover templates	front cover, back cover
Added Inclusive Language acknowledgment	Important User Info
Updated Additional Resources	7
Updated section Bulletin 140M/140MT (Self-protected Combination Controller)/UL489 Circuit Breakers	17
Added 140MT motor protectors and 100-E contactors to table Minimum Recommended Branch Circuit Protective Devices	18
Updated footnote for table Minimum Recommended Branch Circuit Protective Devices	19
Updated section Circuit Breakers	99
Added 140MT motor protectors and 100-E contactors to table Drive Ratings	100
Updated Approvals	101
Updated footnote for table Specifications	101
Updated table Dynamic Brake Modules	106
Updated table Communication Option Kits	109
Updated table Programming Software	110

The information below summarizes the changes made for the June 2013 PowerFlex 40 Adjustable Frequency AC Drive User Manual, publication 22B-UM001I-EN-E.

Description of New or Updated Information	Page
Minimum Enclosure Volume column and new footnotes added	18 , 100
Drive, Fuse and Circuit Breaker Ratings topic updated	99
Electronic Motor Overload Protection description updated	102

Summary of Changes

The information below summarizes the changes made for the August 2008 PowerFlex 40 Adjustable Frequency AC Drive User Manual, publication 22B-UM001H-EN-E.

Description of New or Updated Information	Page
Minimum Enclosure Volume column and new footnotes added	18, 100
Drive, Fuse and Circuit Breaker Ratings topic updated	99
Electronic Motor Overload Protection description updated	102

The information below summarizes the changes made for the April 2008 release PowerFlex 40 Adjustable Frequency AC Drive User Manual, publication 22B-UM001G-EN-E.

Description of New or Updated Information	Page
Description of A056 revised	61
Description of A059/A062 revised	63
Fault description for F3 revised	93
A table row for electrical specifications added	102
Graphic for the "Network Wiring" section revised	123
Second last paragraph in the "Network Wiring" section revised	124
Text in the "Writing (06) Logic Command Data" section revised	126
Frequency source for logic command 001 of bits 14, 13, and 12 corrected	126
Text in the "Writing (06) Reference" section revised	127

The information below summarizes the changes made for the January 2007 PowerFlex 40 Adjustable Frequency AC Drive User Manual, publication 22B-UM001F-EN-E.

Description of New or Updated Information	Page
Input description and attention text for Multiple Digital Input Connection example corrected	32
New method of changing speed reference for IP66, NEMA/UL Type 4X rated drives described	38
Description for Up Arrow and Down Arrow keys revise	40
Fault description for F3 revised	93
Graphic for the "Network Wiring" section revised	123
Descriptions for bits 6, 7, and 15 of register address 8192 (Logic Command) updated	126
New information on reading register address 8192 added	126
New information on reading register address 8193 added	127
Graphic for the "Connecting an RS-485 Network" section corrected	132
New method for inverting sign of PID error added	146

Table of Contents

Preface	Overview	
		Who Should Use this Manual 7
		Reference Materials 7
		Manual Conventions 8
		Drive Frame Sizes 8
		General Precautions 9
		Catalog Number Explanation 10
Chapter 1	Installation/Wiring	
		Opening the Cover 11
		Mounting Considerations 13
		AC Supply Source Considerations 14
		General Grounding Requirements 16
		Fuses and Circuit Breakers 17
		IP66, NEMA/UL Type 4X Installations 24
		I/O Wiring Recommendations 24
		Start and Speed Reference Control 33
		EMC Instructions 35
Chapter 2	Start Up	
		Prepare For Drive Start-Up 37
		Integral Keypad 40
		Viewing and Editing Parameters 41
		Remote HIM Menu Structure 42
Chapter 3	Programming and Parameters	
		About Parameters 45
		Parameter Organization 46
		Display Group 47
		Basic Program Group 53
		Advanced Program Group 58
		Parameter Cross Reference – by Name 89
Chapter 4	Troubleshooting	
		Drive Status 91
		Faults 91
		Fault Descriptions 93
		Common Symptoms and Corrective Actions 95
Appendix A	Supplemental Drive Information	
		Drive, Fuse, and Circuit Breaker Ratings 99
		Specifications 100
Appendix B	Accessories and Dimensions	
		Product Selection 105
		Product Dimensions 110

Table of Contents

Appendix C	RS-485 (DSI) Protocol	
		Network Wiring 123
		Parameter Configuration 125
		Supported Modbus Function Codes 125
		Writing (06) Logic Command Data 126
		Writing (06) Reference 127
		Reading (03) Logic Status Data 127
		Reading (03) Feedback 127
		Reading (03) Drive Error Codes 128
		Reading (03) and Writing (06) Drive Parameters 128
		Additional Information 128
Appendix D	RJ45 DSI Splitter Cable	
		Connectivity Guidelines 129
		DSI Cable Accessories 130
		Connecting One Temporary Peripheral . . . 131
		Connecting One Temporary Peripheral and One Permanent Peripheral 131
		Connecting Two Permanent Peripherals . . 132
		Connecting an RS-485 Network 132
Appendix E	StepLogic, Basic Logic, Timer/Counter	
		StepLogic Using Timed Steps 134
		StepLogic Using Basic Logic Functions . . 134
		Timer Function 136
		Counter Function 137
Appendix F	PID Set Up	
		PID Loop 141
		PID Reference and Feedback 144
		Analog PID Reference Signals 145
Index	 151

Overview

The purpose of this manual is to provide you with the basic information that is needed to install, startup, and troubleshoot the PowerFlex 40 adjustable frequency AC drive.

Who Should Use this Manual

This manual is intended for qualified personnel. You must be able to program and operate Adjustable Frequency AC Drive devices. In addition, you must have an understanding of the parameter settings and functions.

Additional Resources

These documents contain additional information concerning related products from Rockwell Automation. You can view or download publications at rok.auto/literature.

Resource	Description
AC Drive Installation Considerations Installation Instructions, publication DRIVES-IN003	Provides additional information that is needed to install PowerFlex AC drives properly.
Wiring and Grounding for Pulse Width Modulated (PWM) AC Drives Installation Instructions, publication DRIVES-IN001	Provides basic information that is needed to wire and ground PWM AC drives properly.
PowerFlex AC Drive Performance Specifications per Ecodesign Regulation (EU) 2019/1781 and UK SI 2021 No. 745, Technical Data, publication PFLEX-TD003	Provides specifications per Ecodesign Regulation (EU) 2019/1781 and UK SI 2021 No. 745, including efficiency class.
Preventive Maintenance Checklist of Industrial Control and Drive System Equipment Technical Data, publication DRIVES-TD001	Provides checklist on performing preventive maintenance for industrial control and drive system equipment.
Guarding Against Electrostatic Damage (ESD) Service Bulletin, publication 8000-4.5.2	Provides information on causes of ESD, and how you can guard against its effects.
Industrial Automation Wiring and Grounding Guidelines, publication 1770-4.1	Provides general guidelines for installing a Rockwell Automation industrial system.
Safety Guidelines for the Application, Installation, and Maintenance of Solid-State Control Installation Instructions, publication SGI-1.1	Provide general guidelines for the application, installation, and maintenance of solid-state control in the form of individual devices or packaged assemblies incorporating solid-state components.
Product Certifications website, rok.auto/certifications	Provides declarations of conformity, certificates, and other certification details.

Manual Conventions

- In this manual we refer to the PowerFlex 40 Adjustable Frequency AC Drive as; drive, PowerFlex 40 or PowerFlex 40 Drive.
- Parameter numbers and names are shown in this format:

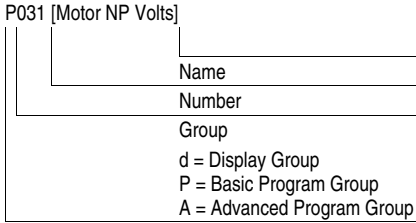

- The following words are used throughout the manual to describe an action:

Word	Meaning
Can	Possible, able to do something
Cannot	Not possible, not able to do something
May	Permitted, allowed
Must	Unavoidable, you must do this
Shall	Required and necessary
Should	Recommended
Should Not	Not Recommended

Drive Frame Sizes

Similar PowerFlex 40 drive sizes are grouped into frame sizes to simplify spare parts ordering, dimensioning, and so on. A cross reference of drive catalog numbers and their respective frame sizes is provided in [Appendix B](#).

General Precautions



ATTENTION: The drive contains high voltage capacitors which take time to discharge after removal of mains supply. Before working on drive, ensure isolation of mains supply from line inputs [R, S, T (L1, L2, L3)]. Wait three minutes for capacitors to discharge to safe voltage levels. Failure to do so may result in personal injury or death.

Darkened display LEDs is not an indication that capacitors have discharged to safe voltage levels.



ATTENTION: Only qualified personnel familiar with adjustable frequency AC drives and associated machinery should plan or implement the installation, start-up and subsequent maintenance of the system. Failure to comply may result in personal injury and/or equipment damage.



ATTENTION: This drive contains ESD (Electrostatic Discharge) sensitive parts and assemblies. Static control precautions are required when installing, testing, servicing or repairing this assembly. Component damage may result if ESD control procedures are not followed. If you are not familiar with static control procedures, see [Guarding Against Electrostatic Damage Service Bulletin](#), publication [8000-4.5.2](#) or any other applicable ESD protection handbook.



ATTENTION: An incorrectly applied or installed drive can result in component damage or a reduction in product life. Wiring or application errors, such as, undersizing the motor, incorrect or inadequate AC supply, or excessive ambient temperatures may result in malfunction of the system.



ATTENTION: The bus regulator function is extremely useful for preventing nuisance overvoltage faults resulting from aggressive decelerations, overhauling loads, and eccentric loads. However, it can also cause either of the following two conditions to occur.

- Fast positive changes in input voltage or imbalanced input voltages can cause uncommanded positive speed changes;
 - Actual deceleration times can be longer than commanded deceleration times
- However, a “Stall Fault” is generated if the drive remains in this state for 1 minute. If this condition is unacceptable, the bus regulator must be disabled (see parameter [A117](#)). In addition, installing a properly sized dynamic brake resistor will provide equal or better performance in most cases.

Catalog Number Explanation

1-3	4	5	6-8	9	10	11	12 ⁽¹⁾	13-14
22B	-	A	1P5	N	1	1	4	AA
Drive	Dash	Voltage Rating	Rating	Enclosure	HIM	Emission Class	Type	Optional

Code
22B PowerFlex 40

Code **Version**
3 No Brake IGBT
4 Standard

Code **Voltage** **Phase**
V 120V AC 1
A 240V AC 1
B 240V AC 3
D 480V AC 3
E 600V AC 3

Code **Rating**
0 Not Filtered
1 Filtered

Code **Interface Module** **Code** **Purpose**
1 Fixed Keypad AA Reserved for
... Custom firmware
ZZ

Code**Enclosure**
N Panel Mount - IP20, NEMA/UL Type Open
C Panel Mount - IP66, NEMA/UL Type 4X
F Flange Mount - IP20, NEMA/UL Type Open
H Replacement Plate Drive - IP20, NEMA/UL Type Open
- Contact factory for ordering information.

Output Current
@ 100...120V 50/60 Hz Input

Code	Amps	kW (HP)
2P3	2.3	0.4 (0.5)
5P0	5.0	0.75 (1.0)
6P0	6.0	1.1 (1.5)

Output Current
@ 200...240V 50/60 Hz Input

Code	Amps	kW (HP)
2P3	2.3	0.4 (0.5)
5P0	5.0	0.75 (1.0)
8P0	8.0	1.5 (2.0)
012	12	2.2 (3.0)
017	17.5	3.7 (5.0)
024	24	5.5 (7.5)
033	33	7.5 (10)

Output Current
@ 380...480V 50/60 Hz Input

Code	Amps	kW (HP)
1P4	1.4	0.4 (0.5)
2P3	2.3	0.75 (1.0)
4P0	4.0	1.5 (2.0)
6P0	6.0	2.2 (3.0)
010	10.5	4.0 (5.0)
012	12	5.5 (7.5)
017	17	7.5 (10)
024	24	11 (15)

Output Current
@ 500...600V 50/60 Hz Input

Code	Amps	kW (HP)
1P7	1.7	0.75 (1.0)
3P0	3.0	1.5 (2.0)
4P2	4.2	2.2 (3.0)
6P6	6.6	4.0 (5.0)
9P9	9.9	5.5 (7.5)
012	12.2	7.5 (10)
019	19	11 (15)

⁽¹⁾ Position 12 of the Catalog Number now indicates drive type. All PowerFlex 40 drives are equipped with RS-485 communication.

Additional accessories, options, and adapters are available. See [Appendix B](#) for details.

Installation/Wiring

This chapter provides information on mounting and wiring the PowerFlex 40 drive.

Most start-up difficulties are the result of incorrect wiring. Every precaution must be taken to assure that the wiring is done as instructed. All items must be read and understood before the actual installation begins.



ATTENTION: The following information is merely a guide for proper installation. Rockwell Automation, Inc. cannot assume responsibility for the compliance or the noncompliance to any code, national, local or otherwise for the proper installation of this drive or associated equipment. A hazard of personal injury and/or equipment damage exists if codes are ignored during installation.

Opening the Cover

IP20, NEMA/UL Type Open

1. Press and hold in the tabs on each side of the cover.
2. Pull the cover out and up to release.

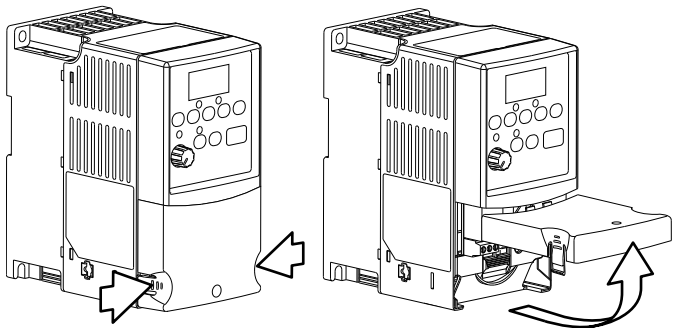

IP66, NEMA/UL Type 4X



ATTENTION: To avoid an electric shock hazard, ensure isolation of mains supply from line inputs [R, S, T (L1, L2, L3)] and wait three minutes for capacitors to discharge before removing the external cover. Once the cover is removed, verify that the voltage on the bus capacitors has discharged before performing any work on the drive. Measure the DC bus voltage at the DC- and DC+ terminals on the Power Terminal Block (see [page 22](#) for Power Terminal descriptions). The voltage must be zero.

1. Loosen the four captive cover screws.
2. Pull cover straight off chassis.

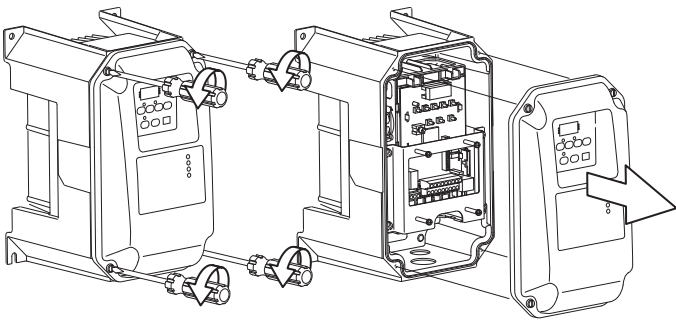

IP66, NEMA/UL Type 4X Cover Installation

1. Squarely align the cover on the chassis.
2. Lightly tighten the four captive cover screws.
3. Torque the cover screws using an alternating pattern.

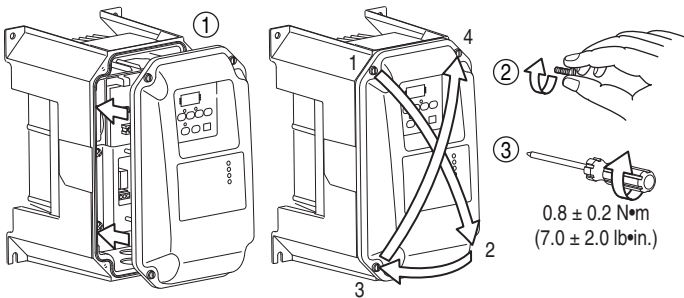

Mounting Considerations

- Mount the drive upright on a flat, vertical and level surface.

Frame	Screw Size	Screw Torque	DIN Rail
B	M4 (#8...32)	1.56...1.96 N•m (14...17 lb•in)	35 mm (1.377 in.)
C	M5 (#10...24)	2.45...2.94 N•m (22...26 lb•in)	–
B (IP66, Type 4X)	M6 (#12...24)	3.95...4.75 N•m (35...42 lb•in)	–

- Protect the cooling fan by avoiding dust or metallic particles.
- Do not expose to a corrosive atmosphere.
- Protect from moisture and direct sunlight.

Minimum Mounting Clearances

See [Appendix B](#) for mounting dimensions.

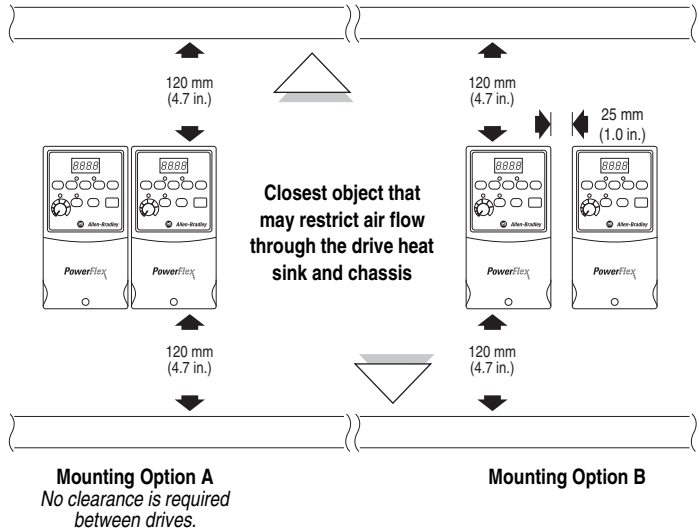

Ambient Operating Temperatures

Table 1 – Enclosure and Clearance Requirements

Ambient Temperature		Enclosure Rating	Minimum Mounting Clearances
Minimum	Maximum		
-10 °C (14 °F)	40 °C (104 °F)	IP20, NEMA/UL Type Open	Use Mounting Option A
		IP66, NEMA/UL Type 4X	Use Mounting Option A
		IP30, NEMA/UL Type 1 ⁽¹⁾	Use Mounting Option B
	50 °C (122 °F)	IP20, NEMA/UL Type Open	Use Mounting Option B

⁽¹⁾ Rating requires installation of the PowerFlex 40 IP30, NEMA/UL Type 1 option kit.

Debris Protection

A plastic top panel is included with the drive. Install the panel to prevent debris from falling through the vents of the drive housing during installation. Remove the panel for IP20, NEMA/UL Type Open applications.

Storage

- Store within an ambient temperature range of -40...+85 °C (-40...+185 °F).
- Store within a relative humidity range of 0...95%, non-condensing.
- Do not expose to a corrosive atmosphere.

AC Supply Source Considerations

Ungrounded Distribution Systems



ATTENTION: PowerFlex 40 drives contain protective MOVs that are referenced to ground. These devices must be disconnected if the drive is installed on an ungrounded or resistive grounded distribution system.

Disconnecting MOVs

To prevent drive damage, the MOVs connected to ground shall be disconnected if the drive is installed on an ungrounded distribution system where the line-to-ground voltages on any phase could exceed 125% of the nominal line-to-line voltage. To disconnect these devices, remove the jumper shown in [Figure 1](#) and [Figure 2](#).

1. Turn the screw counterclockwise to loosen.
2. Pull the jumper completely out of the drive chassis.
3. Tighten the screw to keep it in place.

Figure 1 – Jumper Location (Typical)

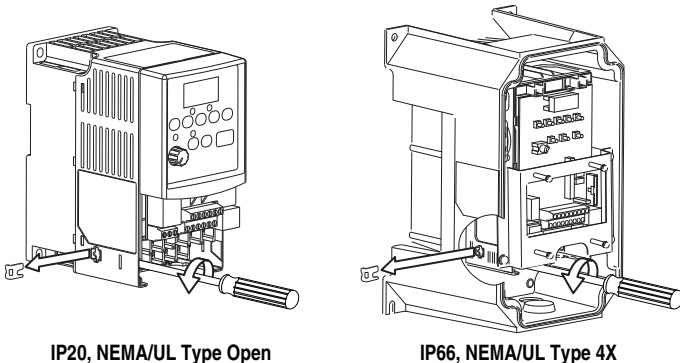

Important: Tighten screw after jumper removal.

Figure 2 – Phase to Ground MOV Removal

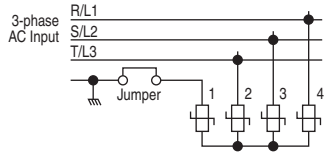

Input Power Conditioning

The drive is suitable for direct connection to input power within the rated voltage of the drive (see [Appendix A](#)). Listed in [Table 2](#) are certain input power conditions which may cause component damage or reduction in product life. If any of the conditions exist, as described in [Table 2](#), install one of the devices listed under the heading Corrective Action on the line side of the drive.

Important: Only one device per branch circuit is required. It should be mounted closest to the branch and sized to handle the total current of the branch circuit.

Table 2 – Input Power Conditions

Input Power Condition	Corrective Action
Low Line Impedance (less than 1% line reactance)	Install Line Reactor ⁽²⁾ or Isolation Transformer or Bus Inductor – 5.5 kW (7.5 HP) and 11 kW (15 HP) drives only
Greater than 120 kVA supply transformer	
Line has power factor correction capacitors	Install Line Reactor or Isolation Transformer
Line has frequent power interruptions	
Line has intermittent noise spikes in excess of 6000V (lightning)	
Phase to ground voltage exceeds 125% of normal line to line voltage	Remove MOV jumper to ground or Install Isolation Transformer with grounded secondary if necessary.
Ungrounded distribution system	
240V open delta configuration (stinger leg) ⁽¹⁾	Install Line Reactor

(1) For drives applied on an open delta with a middle phase grounded neutral system, the phase opposite the phase that is tapped in the middle to the neutral or earth is referred to as the “stinger leg,” “high leg,” “red leg,” and so on. This leg should be identified throughout the system with red or orange tape on the wire at each connection point. The stinger leg should be connected to the center Phase B on the reactor. See [Table 4](#) for specific line reactor part numbers.

(2) See [Appendix B](#) for accessory ordering information.

General Grounding Requirements

The drive Safety Ground - \oplus (PE) must be connected to system ground. Ground impedance must conform to the requirements of national and local industrial safety regulations and/or electrical codes. The integrity of all ground connections should be periodically checked.

Figure 3 – Typical Grounding

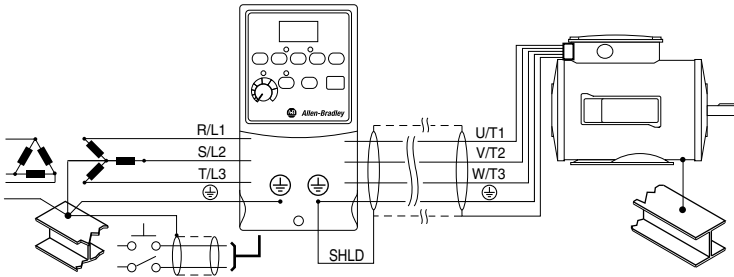

Ground Fault Monitoring

If a system ground fault monitor (RCD) is to be used, only Type B (adjustable) devices should be used to avoid nuisance tripping.

Safety Ground - \oplus (PE)

This is the safety ground for the drive that is required by code. One of these points must be connected to adjacent building steel (girder, joist), a floor ground rod or bus bar. Grounding points must comply with national and local industrial safety regulations and/or electrical codes.

Motor Ground

The motor ground must be connected to one of the ground terminals on the drive.

Shield Termination - SHLD

Either of the safety ground terminals located on the power terminal block provides a grounding point for the motor cable shield. The **motor cable** shield connected to one of these terminals (drive end) should also be connected to the motor frame (motor end). Use a shield terminating or EMI clamp to connect the shield to the safety ground terminal. The conduit box option may be used with a cable clamp for a grounding point for the cable shield.

When shielded cable is used for **control and signal wiring**, the shield should be grounded at the source end only, not at the drive end.

RFI Filter Grounding

Using single phase drives with integral filter, or an external filter with any drive rating, may result in relatively high ground leakage currents. Therefore, the **filter must only be used in installations with grounded AC supply systems and be permanently installed and solidly grounded** (bonded) to the building power distribution ground. Ensure that the incoming supply neutral is solidly connected (bonded) to the same building power distribution ground. Grounding must not rely on flexible cables and should not include any form of plug or socket that would permit inadvertent disconnection. Some local codes may require redundant ground connections. The integrity of all connections should be periodically checked.

Fuses and Circuit Breakers

The PowerFlex 40 drive does not provide branch short circuit protection. This product should be installed with either input fuses or an input circuit breaker. National and local industrial safety regulations and/or electrical codes may determine additional requirements for these installations.



ATTENTION: To guard against personal injury and/or equipment damage caused by improper fusing or circuit breaker selection, use only the recommended line fuses/circuit breakers specified in this section.

Fusing

The PowerFlex 40 drive has been UL tested and approved for use with input fuses. The ratings in the table that follows are the minimum recommended values for use with each drive rating. The devices listed in this table are provided to serve as a guide.

Bulletin 140M/140MT (Self-Protected Combination Controller)/ UL489 Circuit Breakers

When using Bulletin 140M/140MT or UL489 rated circuit breakers, the guidelines listed below must be followed in order to meet the NEC requirements for branch circuit protection.

- Bulletin 140M/140MT can be used in single and group motor applications.
- Bulletin 140M/140MT can be used up stream from the drive **without** the need for fuses.

Chapter 1 Installation/Wiring

Table 3 – Minimum Recommended Branch Circuit Protective Devices

Voltage Rating	Drive Rating kW (HP)	Fuse Rating⁽¹⁾ Amps	140M/140MT Motor Protectors⁽²⁾⁽³⁾ Catalog Number	Recommended Contactors Catalog Number	Min. Enclosure Volume⁽⁴⁾ Inches³
120V AC – 1-phase	0.4 (0.5)	15	140M-C2E-C16 140MT-C3E-C16	100-C12 100-E12	1655
	0.75 (1.0)	35	140M-D8E-C20 140MT-D9E-C20	100-C23 100-E26	1655
	1.1 (1.5)	40	140M-F8E-C32	100-C37 100-E38	1655
240V AC – 1-phase	0.4 (0.5)	10	140M-C2E-B63 140MT-C3E-B63	100-C09 100-E09	1655
	0.75 (1.0)	20	140M-C2E-C16 140MT-C3E-C16	100-C12 100-E12	1655
	1.5 (2.0)	30	140M-D8E-C20 140MT-D9E-C20	100-C23 100-E26	1655
	2.2 (3.0)	40	140M-F8E-C32	100-C37 100-E38	2069
240V AC – 3-phase	0.4 (0.5)	6	140M-C2E-B40 140MT-C3E-B40	100-C09 100-E09	1655
	0.75 (1.0)	10	140M-C2E-C10 140MT-C3E-C10	100-C09 100-E09	1655
	1.5 (2.0)	15	140M-C2E-C16 140MT-C3E-C16	100-C12 100-E12	1655
	2.2 (3.0)	25	140M-C2E-C16 140MT-C3E-C16	100-C23 100-E26	1655
	3.7 (5.0)	30	140M-F8E-C25	100-C23 100-E26	1655
	5.5 (7.5)	40	140M-F8E-C32	100-C37 100-E38	2069
	7.5 (10.0)	60	140M-F8E-C45	100-C60 100-E65	2069
480V AC – 3-phase	0.4 (0.5)	3	140M-C2E-B25 140MT-C3E-B25	100-C09 100-E09	1655
	0.75 (1.0)	6	140M-C2E-B40 140MT-C3E-B40	100-C09 100-E09	1655
	1.5 (2.0)	10	140M-C2E-B63 140MT-C3E-B63	100-C09 100-E09	1655
	2.2 (3.0)	15	140M-C2E-C10 140MT-C3E-C10	100-C09 100-E09	1655
	4.0 (5.0)	20	140M-C2E-C16 140MT-C3E-C16	100-C23 100-E26	1655
	5.5 (7.5)	25	140M-D8E-C20 140MT-D9E-C20	100-C23 100-E26	2069
	7.5 (10.0)	30	140M-D8E-C20 140MT-D9E-C20	100-C23 100-E26	2069
	11 (15)	50	140M-F8E-C32	100-C43 100-E40	2069

Table 3 – Minimum Recommended Branch Circuit Protective Devices (Continued)

Voltage Rating	Drive Rating kW (HP)	Fuse Rating ⁽¹⁾ Amps	140M/140MT Motor Protectors ⁽²⁾⁽³⁾ Catalog Number	Recommended Contactors Catalog Number	Min. Enclosure Volume ⁽⁴⁾ Inches ³
600V AC – 3-phase	0.75 (1.0)	6	140M-C2E-B25 140MT-C3E-B25	100-C09 100-E09	1655
	1.5 (2.0)	6	140M-C2E-B40 140MT-C3E-B40	100-C09 100-E09	1655
	2.2 (3.0)	10	140M-D8E-B63 140MT-D9E-B63	100-C09 100-E09	1655
	4.0 (5.0)	15	140M-D8E-C10 140MT-D9E-C10	100-C09 100-E09	1655
	5.5 (7.5)	20	140M-D8E-C16 140MT-D9E-C16	100-C16 100-E16	2069
	7.5 (10.0)	25	140M-D8E-C16 140MT-D9E-C16	100-C23 100-E26	2069
	11 (15)	40	140M-F8E-C25	100-C30 100-E30	2069

- (1) Recommended Fuse Type: UL Class J, CC, T, or Type BS88; 600V (550V) or equivalent.
- (2) The AIC ratings of the Bulletin 140M/140MT devices can vary. See the Motor Protection Circuit Breaker and Motor Circuit Protector Specifications Technical Data, publication [140-TD005](#) or [140M-TD002](#).
- (3) Manual Self-protected (Type E) Combination Motor Controller, UL listed for 208 Wye or Delta, 240 Wye or Delta, 480Y/277 or 600Y/347. Not UL listed for use on 480V or 600V Delta/Delta, corner ground, or high-resistance ground systems.
- (4) When using a Manual Self-protected (Type E) Combination Motor Controller, the drive must be installed in a ventilated or non-ventilated enclosure with the minimum volume specified in this column. Application specific thermal considerations may require a larger enclosure.



ATTENTION: National Codes and standards (NEC, VDE, BSI, and so on) and local codes outline provisions for safely installing electrical equipment. Installation must comply with specifications regarding wire types, conductor sizes, branch circuit protection and disconnect devices. Failure to do so may result in personal injury and/or equipment damage.



ATTENTION: To avoid a possible shock hazard caused by induced voltages, unused wires in the conduit must be grounded at both ends. For the same reason, if a drive sharing a conduit is being serviced or installed, all drives using this conduit should be disabled. This will help minimize the possible shock hazard from “cross coupled” power leads.

Motor Cable Types Acceptable for 200...600 Volt Installations

A variety of cable types are acceptable for drive installations. For many installations, unshielded cable is adequate, provided it can be separated from sensitive circuits. As an approximate guide, allow a spacing of 0.3 m (1 ft) for every 10 m (32.8 ft) of length. In all cases, long parallel runs must be avoided. Do not use cable with an insulation thickness less than 15 mils (0.4 mm/[0.015 in.]). Do not route more than three sets of motor leads in a single conduit to minimize “cross talk”. If more than three drive/motor connections per conduit are required, shielded cable must be used.

UL installations in 50 °C (122 °F) ambient must use 600V, 75 °C (167 °F) or 90 °C (194 °F) wire.

UL installations in 40 °C (104 °F) ambient should use 600V, 75 °C (167 °F) or 90 °C (194 °F) wire.

Use copper wire only. Wire gauge requirements and recommendations are based on 75 °C (167 °F). Do not reduce wire gauge when using higher temperature wire.

Unshielded

THHN, THWN or similar wire is acceptable for drive installation in dry environments provided adequate free air space and/or conduit fill rates limits are provided. **Do not use THHN or similarly coated wire in wet areas.** Any wire chosen must have a minimum insulation thickness of 15 mils (0.4 mm/[0.015 in.]) and should not have large variations in insulation concentricity.

Shielded/Armored Cable

Shielded cable contains all of the general benefits of multi-conductor cable with the added benefit of a copper braided shield that can contain much of the noise generated by a typical AC drive. Strong consideration for shielded cable should be given in installations with sensitive equipment such as weigh scales, capacitive proximity switches and other devices that may be affected by electrical noise in the distribution system. Applications with large numbers of drives in a similar location, imposed EMC regulations or a high degree of communications / networking are also good candidates for shielded cable.

Shielded cable may also help reduce shaft voltage and induced bearing currents for some applications. In addition, the increased impedance of shielded cable may help extend the distance that the motor can be located from the drive without the addition of motor protective devices such as terminator networks. See the Reflected Wave in Wiring and Grounding Guidelines for Pulse-width Modulated (PWM) AC Drives Installation Instructions, publication [DRIVES-IN001](#).

Consideration should be given to all of the general specifications dictated by the environment of the installation, including temperature, flexibility, moisture characteristics and chemical resistance. In addition, a braided shield should be included and be specified by the cable manufacturer as having coverage of at least 75%. An additional foil shield can greatly improve noise containment.

A good example of recommended cable is Belden 295xx (xx determines gauge). This cable has four (4) XLPE insulated conductors with a 100% coverage foil and an 85% coverage copper braided shield (with drain wire) surrounded by a PVC jacket.

Other types of shielded cable are available, but the selection of these types may limit the allowable cable length. Particularly, some of the newer cables twist 4 conductors of THHN wire and wrap them tightly with a foil shield. This construction can greatly increase the cable charging current required and reduce the overall drive performance. Unless specified in the individual distance tables as tested with the drive, these cables are not recommended and their performance against the lead length limits supplied is not known.

Recommended Shielded Wire

Location	Rating/Type	Description
Standard (Option 1)	600V, 90 °C (194 °F) XHHW2/RHW-2 Anixter B209500...B209507, Belden 29501...29507, or equivalent	Four tinned copper conductors with XLPE insulation Copper braid/aluminum foil combination shield and tinned copper drain wire PVC jacket
Standard (Option 2)	Tray rated 600V, 90 °C (194 °F) RHH/RHW-2 Anixter OLF-7xxxxx or equivalent	Three tinned copper conductors with XLPE insulation 5 mil single helical copper tape (25% overlap min.) with three bare copper grounds in contact with shield PVC jacket
Class I and II; Division I and II	Tray rated 600V, 90 °C (194 °F) RHH/RHW-2 Anixter 7V-7xxxx-3G or equivalent	Three bare copper conductors with XLPE insulation and impervious corrugated continuously welded aluminum armor Black sunlight resistant PVC jacket overall Three copper grounds on 6 mm ² (#10 AWG) and smaller

Reflected Wave Protection

The drive should be installed as close to the motor as possible. Installations with long motor cables may require the addition of external devices to limit voltage reflections at the motor (reflected wave phenomena). See [Table 4](#) for recommendations.

The reflected wave data applies to all frequencies 2...16 kHz.

For 240V ratings, reflected wave effects do not need to be considered.

Table 4 – Maximum Cable Length Recommendations

Reflected Wave		
380...480V Ratings	Motor Insulation Rating	Motor Cable Only ⁽¹⁾
	1000 Vp-p	15 m (49 ft)
	1200 Vp-p	40 m (131 ft)
	1600 Vp-p	170 m (558 ft)

⁽¹⁾ Longer cable lengths can be achieved by installing devices on the output of the drive. Consult factory for recommendations.

Output Disconnect

The drive is intended to be commanded by control input signals that will start and stop the motor. A device that routinely disconnects then reapplies output power to the motor for the purpose of starting and stopping the motor should not be used. If it is necessary to disconnect power to the motor with the drive outputting power, an auxiliary contact should be used to simultaneously disable drive control run commands.

Power Terminal Block

The power terminal block is covered by a finger guard. To remove:

1. Press in and hold the locking tab.
2. Slide finger guard down and out.

Replace the finger guard when wiring is complete.

Figure 4 – Power Terminal Block (Typical)

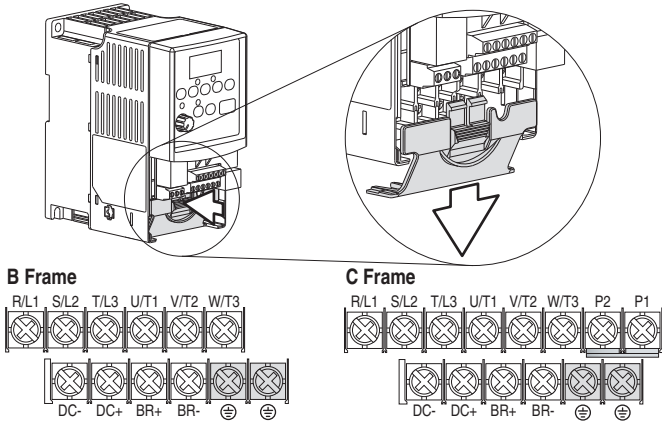

Terminal ⁽¹⁾	Description
R/L1, S/L2	1-phase Input
R/L1, S/L2, T/L3	3-phase Input
U/T1	To Motor U/T1
V/T2	To Motor V/T2
W/T3	To Motor W/T3
P2, P1	DC Bus Inductor Connection (C Frame drives only.) The C Frame drive is shipped with a jumper between Terminals P2 and P1. Remove this jumper only when a DC Bus Inductor is connected. The drive does not power up without a jumper or inductor connected.
DC+, DC-	DC Bus Connection
BR+, BR-	Dynamic Brake Resistor Connection
⊕	Safety Ground - PE

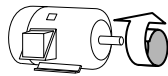

Switch any two motor leads to change forward direction.



⁽¹⁾ **Important:** Terminal screws may become loose during shipment. Ensure that all terminal screws are tightened to the recommended torque before applying power to the drive.

Table 5 – Power Terminal Block Specifications

Frame	Maximum Wire Size ⁽¹⁾	Minimum Wire Size ⁽¹⁾	Torque
B	5.3 mm ² (10 AWG)	1.3 mm ² (16 AWG)	1.7...2.2 N•m (16...19 lb•in)
C	8.4 mm ² (8 AWG)	1.3 mm ² (16 AWG)	2.9...3.7 N•m (26...33 lb•in)

⁽¹⁾ Maximum/Minimum sizes that the terminal block will accept - These are not recommendations.

IP66, NEMA/UL Type 4X Installations

Use the plugs supplied with IP66, NEMA/UL Type 4X rated drives to seal unused holes in the conduit entry plate.

Important: Completely seat the plug inner rim for the best seal.

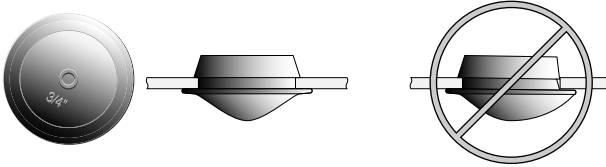

I/O Wiring Recommendations

Motor Start/Stop Precautions



ATTENTION: A contactor or other device that routinely disconnects and reapplies the AC line to the drive to start and stop the motor can cause drive hardware damage. The drive is designed to use control input signals that will start and stop the motor. If used, the input device must not exceed one operation per minute or drive damage can occur.



ATTENTION: The drive start/stop control circuitry includes solid-state components. If hazards due to accidental contact with moving machinery or unintentional flow of liquid, gas or solids exist, an additional hardwired stop circuit may be required to remove the AC line to the drive. When the AC line is removed, there will be a loss of any inherent regenerative braking effect that might be present - The motor will coast to a stop. An auxiliary braking method may be required.

Important points to remember about I/O wiring:

- Always use copper wire.
- Wire with an insulation rating of 600V or greater is recommended.
- Control and signal wires should be separated from power wires by at least 0.3 m (1 ft).

Important: I/O terminals labeled “Common” are not referenced to the safety ground (PE) terminal and are designed to greatly reduce common mode interference.



ATTENTION: Driving the 4...20 mA analog input from a voltage source could cause component damage. Verify proper configuration prior to applying input signals.

Control Wire Types

Table 6 – Recommended Control and Signal Wire⁽¹⁾

Wire Type(s) ⁽²⁾	Description	Minimum Insulation Rating
Belden 8760/9460 (or equivalent)	0.8 mm ² (18 AWG), twisted pair, 100% shield with drain	300V 60 °C (140 °F)
Belden 8770 (or equivalent)	0.8 mm ² (18 AWG), 3 conductor, shielded for remote pot only	

(1) If the wires are short and contained within a cabinet which has no sensitive circuits, the use of shielded wire may not be necessary, but is always recommended.

(2) Stranded or solid wire

I/O Terminal Block

Table 7 – I/O Terminal Block Specifications

Frame	Maximum Wire Size ⁽³⁾	Minimum Wire Size ⁽³⁾	Torque
B and C	1.3 mm ² (16 AWG)	0.2 mm ² (24 AWG)	0.5...0.8 N•m (4.4...7 lb•in)

(3) Maximum/Minimum sizes that the terminal block will accept - These are not recommendations.

Maximum Control Wire Recommendations

Do not exceed control wiring length of 30 m (100 ft). Control signal cable length is highly dependent on electrical environment and installation practices. To improve noise immunity, the I/O terminal block Common must be connected to ground terminal/protective earth. If using the RS-485 (DSI) port, I/O Terminal 16 should also be connected to ground terminal/protective earth.

Table 8 – Control I/O Terminal Designations

No.	Signal	Default	Description	Parameter
R1	Relay N.O.	Fault	Normally open contact for output relay	A055
R2	Relay Common	–	Common for output relay	
R3	Relay N.C.	Fault	Normally closed contact for output relay	A055
Analog Output Select DIP Switch		0...10V	Sets analog output to either voltage or current. Setting must match A065 [Analog Out Sel].	
Sink/Source DIP Switch		Source (SRC)	Inputs can be wired as Sink (SNK) or Source (SRC) via DIP Switch setting.	
01	Stop ⁽¹⁾	Coast	The factory installed jumper or a normally closed input must be present for the drive to start.	P036 ⁽¹⁾
02	Start/Run FWD	Not Active	Command comes from the integral keypad by default. To disable reverse operation, see A095 [Reverse Disable].	P036 , P037
03	Direction/Run REV	Not Active		P036 , P037 , A095
04	Digital Common	–	For digital inputs. Electronically isolated with digital inputs from analog I/O and opto outputs.	
05	Digital Input 1	Preset Freq	Program with A051 [Digital In1 Sel].	A051
06	Digital Input 2	Preset Freq	Program with A052 [Digital In2 Sel].	A052
07	Digital Input 3	Local	Program with A053 [Digital In3 Sel].	A053
08	Digital Input 4	Jog Forward	Program with A054 [Digital In4 Sel].	A054
09	Opto Common	–	For opto-coupled outputs. Electronically isolated with opto outputs from analog I/O and digital inputs.	
11	+24V DC	–	Referenced to Digital Common. Drive supplied power for digital inputs. Maximum output current is 100mA.	
12	+10V DC	–	Referenced to Analog Common. Drive supplied power for 0...10V external potentiometer. Maximum output current is 15mA.	P038
13	±10V In ⁽²⁾	Not Active	For external 0...10V (unipolar) or ±10V (bipolar) input supply (input impedance = 100k ohm) or potentiometer wiper.	P038 , A051...A054 , A123 , A132
14	Analog Common	–	For 0...10V In or 4...20 mA In. Electronically isolated with analog inputs and outputs from digital I/O and opto outputs.	
15	4...20 mA In ⁽²⁾	Not Active	For external 4...20 mA input supply (input impedance = 250 Ω).	P038 , A051...A054 , A132
16	Analog Output	OutFreq 0...10	The default analog output is 0...10V. To convert to a current value, change the Analog Output Select DIP Switch to 0...20 mA. Program with A065 [Analog Out Sel]. Max analog value can be scaled with A066 [Analog Out High]. Maximum Load: 4...20 mA = 525 Ω (10.5V) 0...10V = 1 kΩ (10 mA)	A065 , A066
17	Opto Output 1	MotorRunning	Program with A058 [Opto Out1 Sel]	A058 , A059 , A064
18	Opto Output 2	At Frequency	Program with A061 [Opto Out2 Sel]	A061 , A062 , A064
19	RS-485 (DSI) Shield	–	Terminal should be connected to safety ground - PE when using the RS-485 (DSI) communications port.	

(1) See Footnotes (1) and (4) on [page 26](#).

(2) 0...10V In and 4...20 mA In are distinct input channels and may be connected simultaneously. Inputs may be used independently for speed control or jointly when operating in PID mode.

I/O Wiring Examples

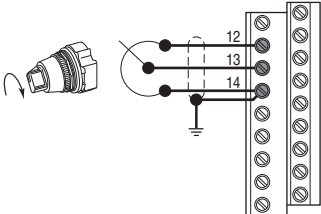
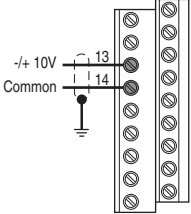
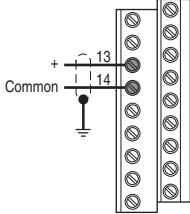
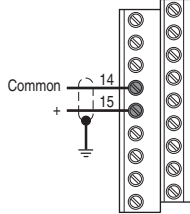
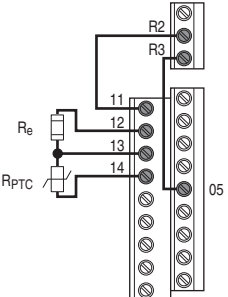
Input/Output	Connection Example		
Potentiometer 1...10 kΩ Pot. Recommended (2 Watt minimum)	<p>P038 [Speed Reference] = 2 "0...10V Input"</p> 		
Analog Input 0...+10V, 100 kΩ impedance 4...20 mA, 250 Ω impedance	Bipolar P038 [Speed Reference] = 2 "0-10V Input" and A123 [10V Bipolar Enbl] = 1 "Bi-Polar In"	Unipolar (Voltage) P038 [Speed Reference] = 2 "0-10V Input"	Unipolar (Current) P038 [Speed Reference] = 3 "4-20mA Input"
			
Analog Input, PTC For Drive Fault	Wire the PTC and External Resistor (typically matched to the PTC Hot Resistance) to I/O Terminals 12, 13, 14. Wire R2/R3 Relay Output (SRC) to I/O Terminals 5 and 11. A051 [Digital In1 Sel] = 3 "Aux Fault" A055 [Relay Out Sel] = 10 "Above Anlg V" A056 [Relay Out Level] = % Voltage Trip		
	 <div style="border: 1px solid black; padding: 5px; width: fit-content; margin: 10px auto;"> $V_{\text{Trip}} = \frac{R_{\text{PTC (hot)}}}{R_{\text{PTC (hot)}} + R_e} \times 100$ </div>		

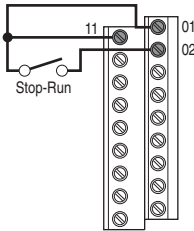
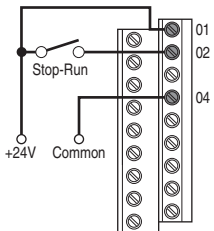
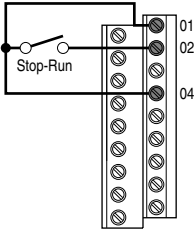
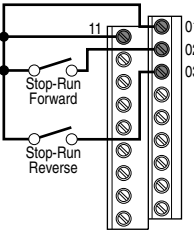
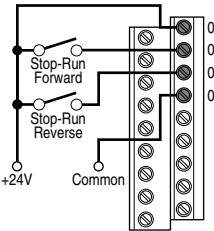
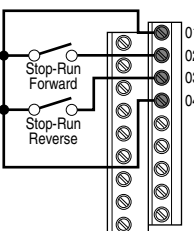

Input/Output	Connection Example	
<p>2-wire SRC Control - Non-reversing</p> <p>P036 [Start Source] = 2, 3, or 4</p> <p>Input must be active for the drive to run. When input is opened, the drive will stop as specified by P037 [Stop Mode].</p> <p>If desired, a User Supplied 24V DC power source can be used. See the "External Supply (SRC)" example.</p>	<p>Internal Supply (SRC)</p> 	<p>External Supply (SRC)</p>  <p>Each digital input draws 6 mA.</p>
<p>2-wire SNK Control - Non-reversing</p>	<p>Internal Supply (SNK)</p> 	
<p>2-wire SRC Control - Run FWD/Run REV</p> <p>P036 [Start Source] = 2, 3, or 4</p> <p>Input must be active for the drive to run. When input is opened, the drive will stop as specified by P037 [Stop Mode].</p> <p>If both Run Forward and Run Reverse inputs are closed at the same time, an undetermined state could occur.</p>	<p>Internal Supply (SRC)</p> 	<p>External Supply (SRC)</p>  <p>Each digital input draws 6 mA.</p>
<p>2-wire SNK Control - Run FWD/Run REV</p>	<p>Internal Supply (SNK)</p> 	

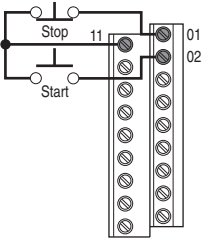
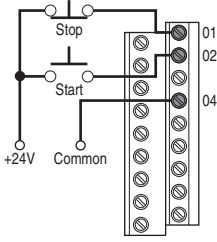
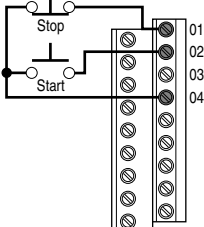
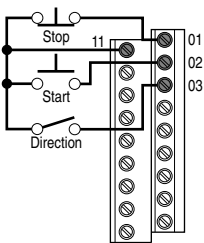
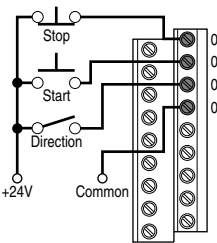
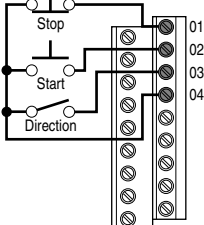
Chapter 1 Installation/Wiring

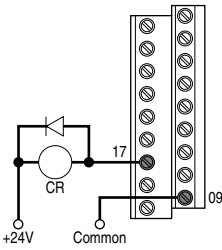
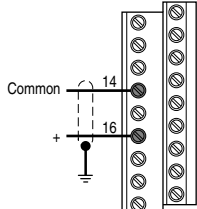
Input/Output	Connection Example	
<p>3-wire SRC Control - Non-reversing</p> <p>P036 [Start Source] = 1</p> <p>A momentary input will start the drive. A stop input to I/O Terminal 01 will stop the drive as specified by P037 [Stop Mode].</p>	<p>Internal Supply (SRC)</p> 	<p>External Supply (SRC)</p>  <p>Each digital input draws 6 mA.</p>
<p>3-wire SNK Control - Non-reversing</p>	<p>Internal Supply (SNK)</p> 	
<p>3-wire SRC Control - Reversing</p> <p>P036 [Start Source] = 1</p> <p>A momentary input will start the drive. A stop input to I/O Terminal 01 will stop the drive as specified by P037 [Stop Mode]. I/O Terminal 03 determines direction.</p>	<p>Internal Supply (SRC)</p> 	<p>External Supply (SRC)</p>  <p>Each digital input draws 6 mA.</p>
<p>3-wire SNK Control - Reversing</p>	<p>Internal Supply (SNK)</p> 	

Input/Output	Connection Example
<p>Opto Output (1 and 2) A058 [Opto Out1 Sel] determines Opto Output 1 (I/O Terminal 17) operation. A061 [Opto Out2 Sel] determines Opto Output 2 (I/O Terminal 18) operation. When using Opto Output with an inductive load such as a relay, install a recovery diode parallel to the relay as shown, to prevent damage to the output.</p>	<p>Opto Output 1</p>  <p>Each Opto Output is rated 30V DC, 50 mA (Non-inductive).</p>
<p>Analog Output A065 [Analog Out Sel] determines analog output type and drive conditions. 0...10V, 1 kΩ minimum 0...20 mA/4...20 mA, 525 Ω maximum</p>	<p>A065 [Analog Out Sel] = 0...14 The Analog Output Select DIP Switch must be set to match the analog output signal mode set in A065 [Analog Out Sel].</p> 

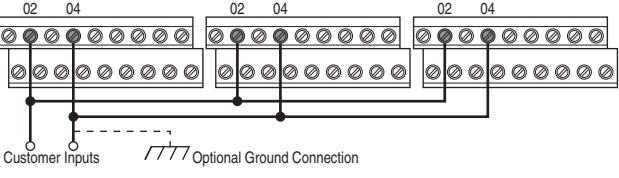
Typical Multiple Drive Connection Examples

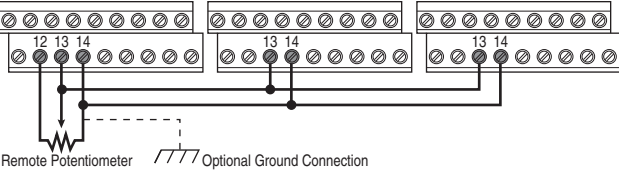
Input/Output	Connection Example
<p>Multiple Digital Input Connections Customer Inputs can be wired per External Supply (SRC) examples on page 29 and page 30.</p>	 <p>When connecting a single input such as Run, Stop, Reverse, or Preset Speeds to multiple drives, it is important to connect I/O Terminal 04 common together for all drives. If they are to be tied into another common (such as earth ground or separate apparatus ground) only one point of the daisy chain of I/O Terminal 04 should be connected.</p> <div style="border: 1px solid black; padding: 5px; margin: 10px 0;">  <p>ATTENTION: Digital inputs on multiple drives should not be tied together when using SNK (Internal Supply) mode. In SNK mode, if power is removed from one drive, inadvertent operation of other drives that share the same I/O Common connection may occur.</p> </div>
<p>Multiple Analog Connections</p>	 <p>When connecting a single potentiometer to multiple drives it is important to connect I/O Terminal 14 common together for all drives. I/O Terminal 14 common and I/O Terminal 13 (potentiometer wiper) should be daisy-chained to each drive. All drives must be powered up for the analog signal to be read correctly.</p>

Start and Speed Reference Control

The drive speed command can be obtained from a number of different sources. The source is normally determined by [P038](#) [Speed Reference]. However, when [A051...A054](#) [Digital Inx Sel] is set to option 2, 4, 5, 6, 11, 12, 13, 14, 15 and the digital input is active, or if A132 is not set to option 0, the speed reference commanded by [P038](#) [Speed Reference] will be overridden. See the chart below for the override priority.

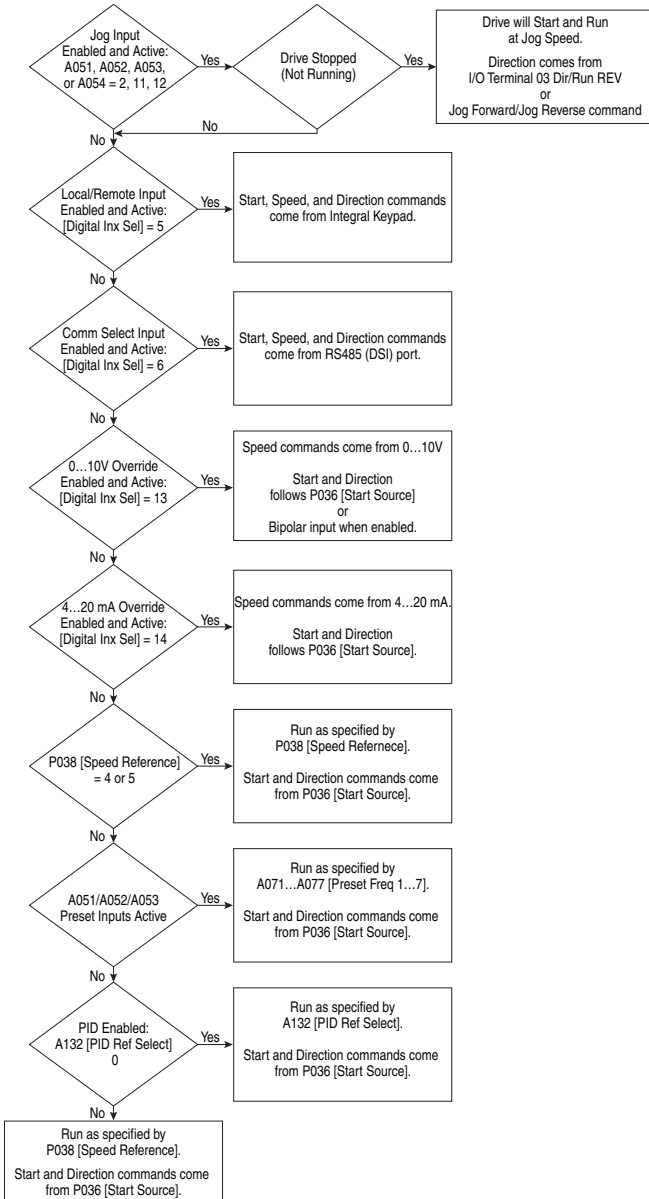

Accel/Decel Selection

The Accel/Decel rate can be obtained by a variety of methods. The default rate is determined by [P039](#) [Accel Time 1] and [P040](#) [Decel Time 1]. Alternative Accel/Decel rates can be made through digital inputs, RS-485 (DSI) communications and/or parameters. See the chart below for the override priority.

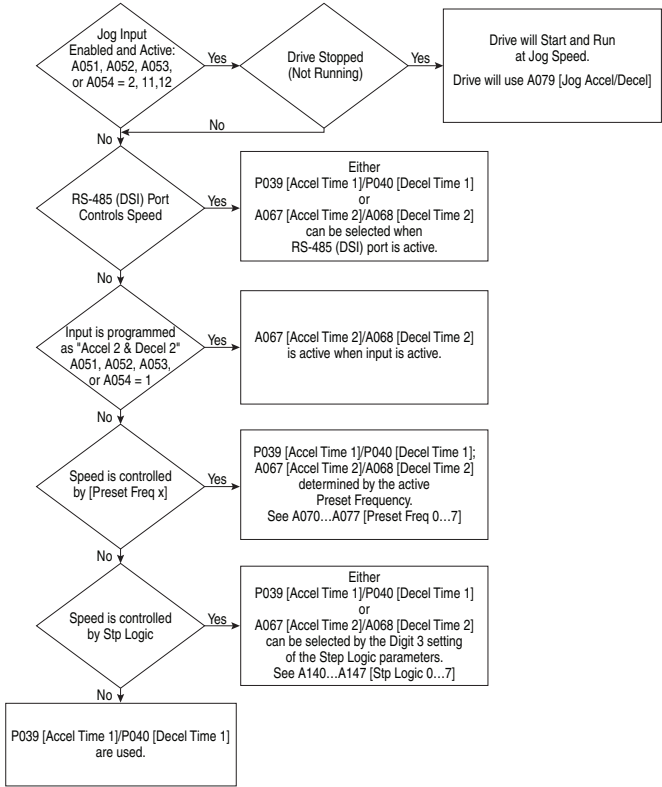

EMC Instructions

CE Conformity

Conformity with the Low Voltage (LV) Directive and Electromagnetic Compatibility (EMC) Directive has been demonstrated using harmonized European Norm (EN) standards published in the Official Journal of the European Communities. PowerFlex 40 drives comply with the EN standards listed below when installed according to the User Manual.

CE Declarations of Conformity are available online at:

rok.auto/certifications.

Low Voltage Directive (2014/35/EU)

- EN61800-5-1 Adjustable speed electrical power drive systems – Part 5-1: Safety requirements – Electrical, thermal and energy.

EMC Directive (2014/30/EU)

- EN61800-3 Adjustable speed electrical power drive systems Part 3: EMC product standard including specific test methods.

General Notes

- If the plastic top panel is removed or the optional conduit box is not installed, the drive must be installed in an enclosure with side openings less than 12.5 mm (0.5 in.) and top openings less than 1.0 mm (0.04 in.) to maintain compliance with the LV Directive.
- The motor cable should be kept as short as possible in order to avoid electromagnetic emission as well as capacitive currents.
- Use of line filters in ungrounded systems is not recommended.
- Conformity of the drive with CE EMC requirements does not guarantee an entire machine installation complies with CE EMC requirements. Many factors can influence total machine/installation compliance.

Essential Requirements for CE Compliance

Conditions 1...3 listed below **must be** satisfied for PowerFlex 40 drives to meet the requirements of EN61800-3.

1. Grounding as described in [Figure 6](#). See [page 17](#) for additional grounding recommendations.
2. Output power, control (I/O), and signal wiring must be braided, shielded cable with a coverage of 75% or better, metal conduit or equivalent attenuation.
3. Allowable cable length in [Table 9](#) is not exceeded.

Table 9 – Allowable Cable Length

Filter Type	EN61800-3 First Environment Restricted Distribution or Second Environment ⁽²⁾	EN61800-3 First Environment Unrestricted Distribution ⁽³⁾
Integral	10 m (33 ft)	1 m (3 ft)
External - S Type ⁽¹⁾	10 m (33 ft)	1 m (3 ft)
External - L Type ⁽¹⁾	100 m (328 ft)	5 m (16 ft)

(1) See [Appendix B](#) for details on optional external filters.

(2) Equivalent to EN55011 Class A

(3) Equivalent to EN55011 Class B

Figure 6 – Connections and Grounding

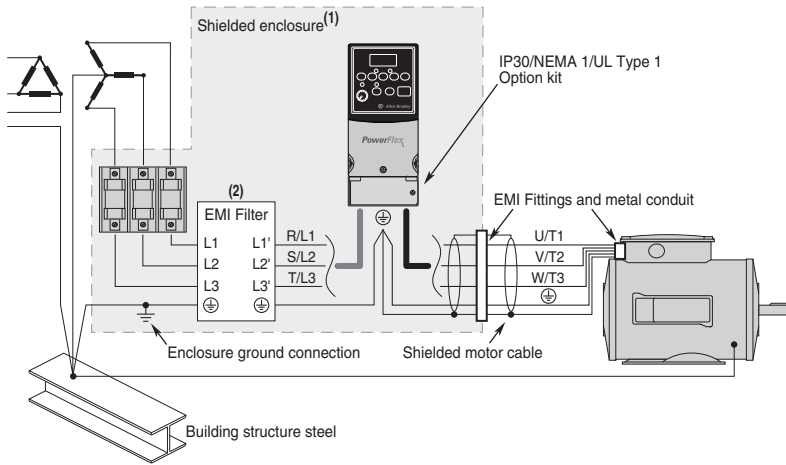

(1) First Environment Unrestricted Distribution installations require a shielded enclosure. Keep wire length as short as possible between the enclosure entry point and the EMI filter.

(2) Integral EMI filters are available on 240V, 1-phase drives.

EN61000-3-2

- 0.75 kW (1 HP) 240V 1-phase and 3-phase drives and 0.37 kW (0.5 HP) 240V 1-phase drives are suitable for installation on a private low voltage power network. Installations on a public low voltage power network may require additional external harmonic mitigation.
- Other drive ratings meet the current harmonic requirements of EN61000-3-2 without additional external mitigation.

Start Up

This chapter describes how to start up the PowerFlex 40 drive. To simplify drive setup, the most commonly programmed parameters are organized in a single Basic Program Group.

Important: Read [General Precautions on page 9](#) before proceeding.



ATTENTION: Power must be applied to the drive to perform the following start-up procedures. Some of the voltages present are at incoming line potential. To avoid electric shock hazard or damage to equipment, only qualified service personnel should perform the following procedure. Thoroughly read and understand the procedure before beginning. If an event does not occur while performing this procedure, **Do Not Proceed. Remove All Power** including user supplied control voltages. User supplied voltages may exist even when main AC power is not applied to the drive. Correct the malfunction before continuing.

Prepare For Drive Start-Up

Before Applying Power to the Drive

- 1. Confirm that all inputs are connected to the correct terminals and are secure.
- 2. Verify that AC line power at the disconnect device is within the rated value of the drive.
- 3. Verify that any digital control power is 24 volts.
- 4. Verify that the Sink (SNK)/Source (SRC) Setup DIP Switch is set to match your control wiring scheme. See [Figure 5](#) for location.

Important: The default control scheme is Source (SRC). The Stop terminal is jumpered (I/O Terminals 01 and 11) to allow starting from the keypad. If the control scheme is changed to Sink (SNK), the jumper must be removed from I/O Terminals 01 and 11 and installed between I/O Terminals 01 and 04.

- 5. Verify that the Stop input is present or the drive will not start.

Important: If I/O Terminal 01 is used as a stop input, the jumper between I/O Terminals 01 and 11 must be removed.

Applying Power to the Drive

- ❑ 1. Apply AC power and control voltages to the drive.
- ❑ 2. Familiarize yourself with the integral keypad features (see [page 40](#)) before setting any Program Group parameters.

If a fault appears on power up, see [Fault Descriptions on page 93](#) for an explanation of the fault code.

Start, Stop, Direction, and Speed Control

Factory default parameter values allow the drive to be controlled from the integral keypad. No programming is required to start, stop, change direction, and control speed directly from the integral keypad.

Important: To disable reverse operation, see [A095](#) [Reverse Disable].

Changing the Speed Reference of an IP66, NEMA/UL Type 4X rated drive

When a Display Group parameter, for example, [d001](#) [Output Freq] is displayed, and [P038](#) [Speed Ref] is set to [A069](#) [Internal Freq], you can change the internal frequency using the Up Arrow and Down Arrow keys.

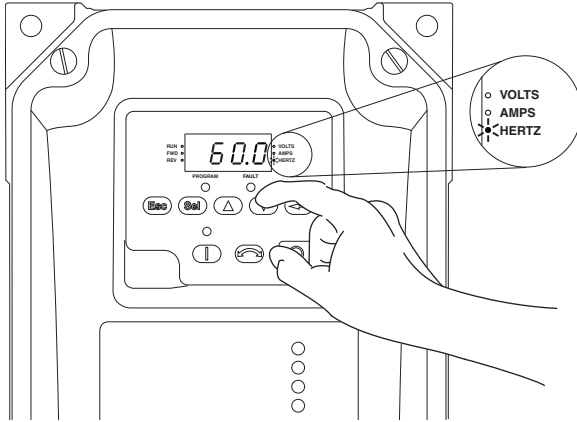

When the internal frequency is being adjusted, its value is displayed and the Hertz LED flashes. Any changes are saved immediately. The display then returns to the Display Group parameter previously shown.

TIP: By default, the speed reference of an IP66, NEMA/UL Type 4X rated drive is set to the internal frequency, [A069](#) [Internal Freq].

TIP: You can also change the speed reference by editing the parameter [A069](#) [Internal Freq] in program mode. For details on how to enter the program mode, see [Viewing and Editing Parameters on page 41](#).

The default value of [A069](#) [Internal Freq] is 0 Hz. For IP20 rated PowerFlex 40 drives, the default value of this parameter is 60 Hz.

Variable Torque Fan/Pump Applications

For improved motor tuning performance when using a premium efficient motor on a variable torque load, set [A084](#) [Boost Select] to option 2 “35.0, VT”.

Integral Keypad

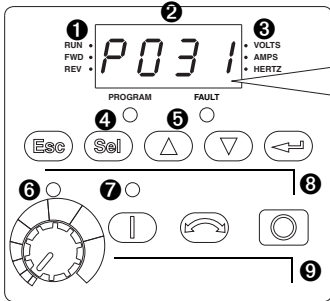

Menu	Description
d	Display Group (View Only) Consists of commonly viewed drive operating conditions.
P	Basic Program Group Consists of most commonly used programmable functions.
A	Advanced Program Group Consists of remaining programmable functions.
F	Fault Designator Consists of list of codes for specific fault conditions. Displayed only when fault is present.







No.	LED	LED State	Description
1	Run/Direction Status	Steady Red	Indicates drive is running and commanded motor direction.
		Flashing Red	Drive has been commanded to change direction. Indicates actual motor direction while decelerating to zero.
2	Alphanumeric Display	Steady Red	Indicates parameter number, parameter value, or fault code.
		Flashing Red	Single digit flashing indicates that digit can be edited. All digits flashing indicates a fault condition.
3	Displayed Units	Steady Red	Indicates the units of the parameter value being displayed.
4	Program Status	Steady Red	Indicates parameter value can be changed.
5	Fault Status	Flashing Red	Indicates drive is faulted.
6	Pot Status	Steady Green	Indicates potentiometer on Integral Keypad is active. ⁽¹⁾
7	Start Key Status	Steady Green	Indicates Start key on Integral Keypad is active. The Reverse key is also active unless disabled by A095 [Reverse Disable].

No.	Key	Name	Description
8		Escape	Back one step in programming menu. Cancel a change to a parameter value and exit Program Mode.
		Select	Advance one step in programming menu. Select a digit when viewing parameter value.
		Up Arrow Down Arrow	Scroll through groups and parameters. Increase/decrease the value of a flashing digit.
			Used to adjust internal frequency of IP66, NEMA/UL Type 4X rated drives <i>only</i> when a Display Group parameter is shown and P038 [Speed Reference] is set to internal frequency, A069 [Internal Freq].
9		Enter	Advance one step in programming menu. Save a change to a parameter value.
		Potentiometer ⁽¹⁾	Used to control speed of drive. Default is active. Controlled by parameter P038 [Speed Reference].
		Start	Used to start the drive. Default is active. Controlled by parameter P036 [Start Source].
		Reverse	Used to reverse direction of the drive. Default is active. Controlled by parameters P036 [Start Source] and A095 [Reverse Disable].
		Stop	Used to stop the drive or clear a fault. This key is always active. Controlled by parameter P037 [Stop Mode].

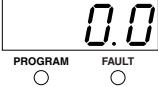
⁽¹⁾ IP66, NEMA/UL Type 4X rated drives are not equipped with a potentiometer.

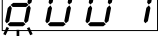
Viewing and Editing Parameters

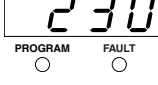
The last user-selected Display Group parameter is saved when power is removed and is displayed by default when power is reapplied. The following is an example of basic integral keypad and display functions. This example provides basic navigation instructions and illustrates how to program the first Program Group parameter.

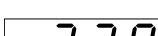
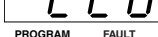
Step	Keys	Example Displays
1. When power is applied, the last user-selected Display Group parameter number is briefly displayed with flashing characters. The display then defaults to that parameter's current value. (Example shows the value of d001 [Output Freq] with the drive stopped.)		
2. Press Esc once to display the Display Group parameter number shown on power-up. The parameter number will flash.		
3. Press Esc again to enter the group menu. The group menu letter will flash.	Esc	
4. Press the Up Arrow or Down Arrow to scroll through the group menu (d, P, and A).		
5. Press Enter or Sel to enter a group. The right digit of the last viewed parameter in that group will flash.	Esc	
6. Press the Up Arrow or Down Arrow to scroll through the parameters that are in the group.	Up Arrow or Down Arrow	
7. Press Enter or Sel to view the value of a parameter. If you do not want to edit the value, press Esc to return to the parameter number.	Left Arrow or Sel	
8. Press Enter or Sel to enter program mode to edit the parameter value. The right digit will flash and the Program LED will illuminate if the parameter can be edited.	Up Arrow or Down Arrow	
9. Press the Up Arrow or Down Arrow to change the parameter value. If desired, press Sel to move from digit to digit or bit to bit. The digit or bit that you can change will flash.	Left Arrow or Sel	
10. Press Esc to cancel a change. The digit will stop flashing, the previous value is restored and the Program LED will turn off. Or Press Enter to save a change. The digit will stop flashing and the Program LED will turn off.	Left Arrow or Sel	
11. Press Esc to return to the parameter list. Continue to press Esc to back out of the programming menu. If pressing Esc does not change the display, then d001 [Output Frequency] is displayed. Press Enter or Sel to enter the group menu.	Up Arrow or Down Arrow	
	Esc	
	Left Arrow	
	Esc	

The Basic Program Group ([page 53](#)) contains the most commonly changed parameters.

Remote HIM Menu Structure

The Menu Structure below can be accessed through the following Human Interface Module (HIM) options:

HIM Option	Catalog Number
Remote Panel Mount Small, LCD Display	22-HIM-C2S
Remote Handheld, LCD Display	22-HIM-A3

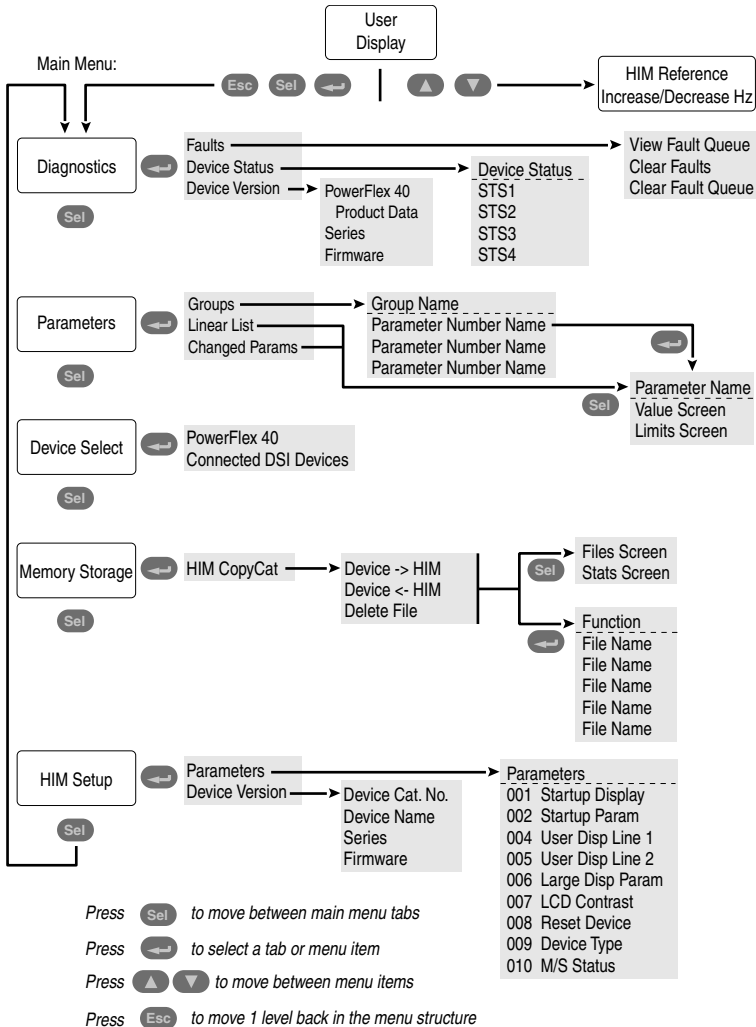

Diagnostics Menu

When a fault trips the drive, use this menu to access detailed data about the drive.

Option	Description
Faults	View fault queue or fault information, clear faults or clear fault queue.
Device Status	View status information about the drive or peripheral.
Device Version	View the firmware version and hardware series of components.

Parameters Menu

Use this menu to access drive parameters. Parameters can be displayed in groups, in a linear list, or only those changed from their defaults.

Device Select Menu

Use this menu to access the drive or peripheral that the drive is to access.

Memory Storage Menu

Drive data can be saved to, or recalled from HIM sets.

HIM sets are files stored in permanent nonvolatile HIM memory.

Option	Description
HIM Copycat Device -> HIM Device <- HIM	Save data to a HIM set or load data from a HIM set to active drive memory. A maximum of 5 HIM set can be stored.
Delete File	Delete a HIM set.

HIM Setup Menu

The HIM and drive have features that you can customize.

Option	Description
Parameters	Access parameters in HIM to set display options.
Device Version	View HIM version, hardware series, and firmware version

Notes:

Programming and Parameters

Chapter 3 provides a complete listing and description of the PowerFlex 40 parameters. Parameters are programmed (viewed/edited) using the integral keypad. As an alternative, programming can also be performed using Connected Components Workbench™ or DriveExecutive™ software, a personal computer and a serial converter module. See [Appendix B](#) for catalog numbers.

About Parameters

To configure a drive to operate in a specific way, drive parameters may have to be set. Three types of parameters exist:

- **ENUM**
ENUM parameters allow a selection from 2 or more items. Each item is represented by a number.
- **Numeric Parameters**
These parameters have a single numerical value (for instance 0.1V).
- **Bit Parameters**
Bit parameters have four individual bits associated with features or conditions. If the bit is 0, the feature is off or the condition is false. If the bit is 1, the feature is on or the condition is true.

Some parameters are marked as follows.

 = Stop drive before changing this parameter.

 = 32-bit parameter. Parameters marked 32-bit will have two parameter numbers when using RS-485 communications and programming software.

Parameter Organization

See [page 89](#) for an alphabetical listing of parameters.

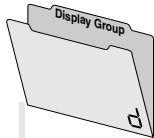

Display Group (page 47)

Output Freq	d001
Commanded Freq	d002
Output Current	d003
Output Voltage	d004
DC Bus Voltage	d005
Drive Status	d006
Fault 1 Code	d007
Fault 2 Code	d008
Fault 3 Code	d009
Process Display	d010
Control Source	d012
Contrl In Status	d013
Dig In Status	d014
Comm Status	d015
Control SW Ver	d016
Drive Type	d017
Elapsed Run Time	d018
Testpoint Data	d019
Analog In 0-10V	d020
Analog In 4-20mA	d021
Output Power	d022
Output Power Fctr	d023
Drive Temp	d024
Counter Status	d025
Timer Status	d026
Stp Logic Status	d028
Torque Current	d029



Advanced Program Group (page 58)

Digital In1 Sel	A051
Digital In2 Sel	A052
Digital In3 Sel	A053
Digital In4 Sel	A054
Relay Out Sel	A055
Relay Out Level	A056
Opto Out1 Sel	A058
Opto Out1 Level	A059
Opto Out2 Sel	A061
Opto Out2 Level	A062
Opto Out Logic	A064
Analog Out Sel	A065
Analog Out High	A066
Accel Time 2	A067
Decel Time 2	A068
Internal Freq	A069
Preset Freq 0	A070
Preset Freq 1	A071
Preset Freq 2	A072
Preset Freq 3	A073
Preset Freq 4	A074
Preset Freq 5	A075
Preset Freq 6	A076
Preset Freq 7	A077
Jog Frequency	A078
Jog Accel/Decel	A079
DC Brake Time	A080
DC Brake Level	A081
DB Resistor Sel	A082
S Curve %	A083
Boost Select	A084
Start Boost	A085
Break Voltage	A086
Break Frequency	A087
Maximum Voltage	A088
Current Limit 1	A089
Motor OL Select	A090
PWM Frequency	A091
Auto Rstrt Tries	A092
Auto Rstrt Delay	A093
Start At PowerUp	A094
Reverse Disable	A095
Flying Start En	A096
Compensation	A097
SW Current Trip	A098
Process Factor	A099
Fault Clear	A100
Program Lock	A101
Testpoint Sel	A102
Comm Data Rate	A103
Comm Node Addr	A104
Comm Loss Action	A105

Advanced Program Group (page 58)

Comm Loss Time	A106
Comm Format	A107
Language	A108
Anlg Out Setpt	A109
Anlg In 0-10V Lo	A110
Anlg In 0-10V Hi	A111
Anlg In4-20mA Lo	A112
Anlg In4-20mA Hi	A113
Slip Hertz @ FLA	A114
Process Time Lo	A115
Process Time Hi	A116
Bus Reg Mode	A117
Current Limit 2	A118
Skip Frequency	A119
Skip Freq Band	A120
Stall Fault Time	A121
Analog In Loss	A122
10V Bipolar Enbl	A123
Var PWM Disable	A124
Torque Perf Mode	A125
Motor NP FLA	A126
Autotune	A127
IR Voltage Drop	A128
Flux Current Ref	A129
PID Trim Hi	A130
PID Trim Lo	A131
PID Ref Sel	A132
PID Feedback Sel	A133
PID Prop Gain	A134
PID Integ Time	A135
PID Diff Rate	A136
PID Setpoint	A137
PID Deadband	A138
PID Preload	A139
Stp Logic 0	A140
Stp Logic 1	A141
Stp Logic 2	A142
Stp Logic 3	A143
Stp Logic 4	A144
Stp Logic 5	A145
Stp Logic 6	A146
Stp Logic 7	A147
Stp Logic Time 0	A150
Stp Logic Time 1	A151
Stp Logic Time 2	A152
Stp Logic Time 3	A153
Stp Logic Time 4	A154
Stp Logic Time 5	A155
Stp Logic Time 6	A156
Stp Logic Time 7	A157
EM Brk Off Delay	A160
EM Brk On Delay	A161
MOP Reset Sel	A162
DB Threshold	A163
Comm Write Mode	A164
Anlg Loss Delay	A165
Analog In Filter	A166
PID Invert Error	A167

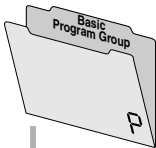

Basic Program Group (page 53)

Motor NP Volts	P031
Motor NP Hertz	P032
Motor OL Current	P033
Minimum Freq	P034
Maximum Freq	P035
Start Source	P036
Stop Mode	P037
Speed Reference	P038
Accel Time 1	P039
Decel Time 1	P040
Reset To Defaults	P041
Voltage Class	P042
Motor OL Ret	P043

Display Group

d001 [Output Freq] Related Parameters: [d002](#), [d010](#), [P034](#), [P035](#), [P038](#)

Output frequency present at T1, T2, and T3 (U, V, and W).

Values	Default:	Read Only
	Min/Max:	0.0/ P035 [Maximum Freq]
	Display:	0.1 Hz

d002 [Commanded Freq] Related Parameters: [d001](#), [d013](#), [P034](#), [P035](#), [P038](#)

Value of the active frequency command. Displays the commanded frequency even if the drive is not running.

Important: The frequency command can come from a number of sources. See [Start and Speed Reference Control on page 33](#) for details.

Values	Default:	Read Only
	Min/Max:	0.0/ P035 [Maximum Freq]
	Display:	0.1 Hz

d003 [Output Current]

The output current present at T1, T2, and T3 (U, V, and W).

Values	Default:	Read Only
	Min/Max:	0.00/(Drive Rated Amps × 2)
	Display:	0.01 Amps

d004 [Output Voltage]

Related Parameters: [P031](#), [A084](#), [A088](#)

Output voltage present at terminals T1, T2, and T3 (U, V, and W).

Values	Default:	Read Only
	Min/Max:	0/Drive Rated Volts
	Display:	1 VAC

d005 [DC Bus Voltage]

Present DC bus voltage level.

Values	Default:	Read Only
	Min/Max:	Based on Drive Rating
	Display:	1 VDC

Display Group *(continued)*

d006 [Drive Status]

Related Parameters: [A095](#)

Present operating condition of the drive.

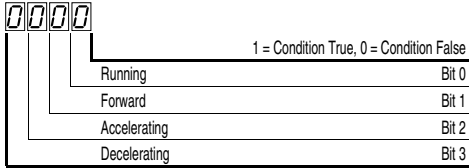

Values	Default:	Read Only
	Min/Max:	0/1
	Display:	1

d007 [Fault 1 Code]

d008 [Fault 2 Code]

d009 [Fault 3 Code]

A code that represents a drive fault. The codes will appear in these parameters in the order they occur ([d007](#) [Fault 1 Code] = the most recent fault). Repetitive faults will only be recorded once.

See [Fault Descriptions on page 93](#) for fault code descriptions.

Values	Default:	Read Only
	Min/Max:	F2/F122
	Display:	F1

d010 [Process Display]

Related Parameters: [d001](#), [A099](#)

 32-bit parameter.

The output frequency scaled by [A099](#) [Process Factor].

$$\text{Output Freq} \times \text{Process Factor} = \text{Process Display}$$

Values	Default:	Read Only
	Min/Max:	0.00/9999
	Display:	0.01 – 1

Display Group *(continued)*

d012 [Control Source]

Related Parameters: [P036](#), [P038](#), [A051...](#)[A054](#)

Displays the active source of the Start Command and Speed Command which are normally defined by the settings of [P036](#) [Start Source] and [P038](#) [Speed Reference] but may be overridden by digital inputs. See the flowcharts on [page 33](#) and [page 34](#) for details.

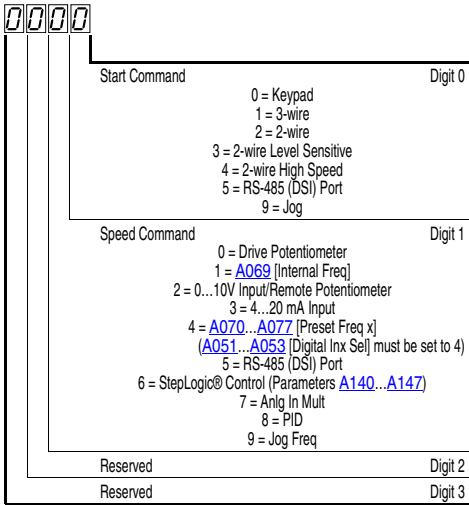

Values	Default:	Read Only
	Min/Max:	0/9
	Display:	1

d013 [Contrl In Status]

Related Parameters: [d002](#), [P034](#), [P035](#)

Status of the control terminal block control inputs.

Important: Actual control commands may come from a source other than the control terminal block.

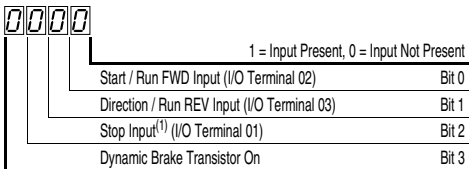

⁽¹⁾ The stop input must be present in order to start the drive. When this bit is a 1 the drive can be started. When this bit is a 0 the drive will stop.

Values	Default:	Read Only
	Min/Max:	0/1
	Display:	1

Display Group *(continued)*

d014 [Dig In Status]

Related Parameters: [A051](#)...[A054](#)

Status of the control terminal block digital inputs.

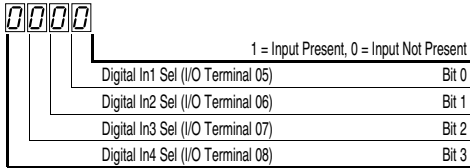

Values	Default:	Read Only
	Min/Max:	0/1
	Display:	1

d015 [Comm Status]

Related Parameters: [A103](#)...[A107](#)

Status of the communications ports.

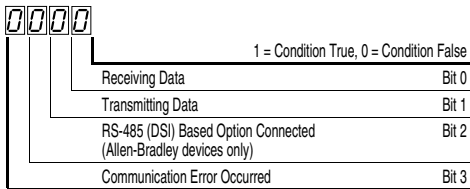

Values	Default:	Read Only
	Min/Max:	0/1
	Display:	1

d016 [Control SW Ver]

Main Control Board software version.

Values	Default:	Read Only
	Min/Max:	1.00/99.99
	Display:	0.01

d017 [Drive Type]

Used by Rockwell Automation field service personnel.

Values	Default:	Read Only
	Min/Max:	1001/9999
	Display:	1

Display Group *(continued)*

d018 [Elapsed Run Time]

Accumulated time drive is outputting power. Time is displayed in 10 hour increments.

Values	Default:	Read Only
	Min/Max:	0/9999 Hrs
	Display:	1 = 10 Hrs

d019 [Testpoint Data]

Related Parameters: [A102](#)

The present value of the function selected in [A102](#) [Testpoint Sel].

Values	Default:	Read Only
	Min/Max:	0/FFFF
	Display:	1 Hex

d020 [Analog In 0-10V]

Related Parameters: [A110](#), [A111](#)

The present value of the voltage at I/O Terminal 13 (100.0% = 10 volts).

Values	Default:	Read Only
	Min/Max:	0.0/100.0%
	Display:	0.1%

d021 [Analog In 4...20 mA]

Related Parameters: [A112](#), [A113](#)

The present value of the current at I/O Terminal 15 (0.0% = 4mA, 100.0% = 20mA).

Values	Default:	Read Only
	Min/Max:	0.0/100.0%
	Display:	0.1%

d022 [Output Power]

Output power present at T1, T2, and T3 (U, V, and W).

Values	Default:	Read Only
	Min/Max:	0.00/(Drive Rated Power × 2)
	Display:	0.01 kW

d023 [Output Powr Fctr]

The angle in electrical degrees between motor voltage and motor current.

Values	Default:	Read Only
	Min/Max:	0.0/180.0 deg
	Display:	0.1 deg

Display Group *(continued)*

d024 [Drive Temp]

Present operating temperature of the drive power section.

Values	Default:	Read Only
	Min/Max:	0/120 degC
	Display:	1 degC

d025 [Counter Status]

The current value of the counter when counter is enabled.

Values	Default:	Read Only
	Min/Max:	0/9999
	Display:	1

d026 [Timer Status]

32-bit parameter.

The current value of the timer when timer is enabled.

Values	Default:	Read Only
	Min/Max:	0.0/9999 Secs
	Display:	0.1 Secs

d028 [Stp Logic Status]

When [P038](#) [Speed Reference] is set to 6 "Stp Logic", this parameter will display the current step of the StepLogic profile as defined by parameters [A140...](#)[A147](#) [Stp Logic x].

Values	Default:	Read Only
	Min/Max:	0/7
	Display:	1

d029 [Torque Current]

The current value of the motor torque current.

Values	Default:	Read Only
	Min/Max:	0.00/(Drive Rated Amps × 2)
	Display:	0.01 Amps

Basic Program Group

P031 [Motor NP Volts]

Related Parameters: [d004](#), [A084](#), [A085](#), [A086](#), [A087](#)



Stop drive before changing this parameter.

Set to the motor nameplate rated volts.

Values	Default:	Based on Drive Rating
	Min/Max:	20/Drive Rated Volts
	Display:	1 VAC

P032 [Motor NP Hertz]

Related Parameters: [A084](#), [A085](#), [A086](#), [A087](#), [A090](#)



Stop drive before changing this parameter.

Set to the motor nameplate rated frequency.

Values	Default:	60 Hz
	Min/Max:	15/400 Hz
	Display:	1 Hz

P033 [Motor OL Current]

Related Parameters: [A055](#), [A058](#), [A061](#), [A089](#), [A090](#),
[A098](#), [A114](#), [A118](#)

Set to the maximum allowable motor current.

The drive will fault on an F7 [Motor Overload](#) if the value of this parameter is exceeded by 150% for 60 seconds.

Values	Default:	Based on Drive Rating
	Min/Max:	0.0/(Drive Rated Amps × 2)
	Display:	0.1 Amps

P034 [Minimum Freq]

Related Parameters: [d001](#), [d002](#), [d013](#), [P035](#), [A085](#),
[A086](#), [A087](#), [A110](#), [A112](#)

Sets the lowest frequency the drive will output continuously.

Values	Default:	0.0 Hz
	Min/Max:	0.0/400.0 Hz
	Display:	0.1 Hz

P035 [Maximum Freq]

Related Parameters: [d001](#), [d002](#), [d013](#), [P034](#), [A065](#),
[A078](#), [A085](#), [A086](#), [A087](#), [A111](#), [A113](#)



Stop drive before changing this parameter.

Sets the highest frequency the drive will output.

Values	Default:	60 Hz
	Min/Max:	0/400 Hz
	Display:	1 Hz

Basic Program Group *(continued)*

P036 [Start Source]

Related Parameters: [d012](#), [P037](#)



Stop drive before changing this parameter.

Sets the control scheme used to start the drive.

See [Start and Speed Reference Control on page 33](#) for details about how other drive settings can override the setting of this parameter.

Important: For all settings except option 3, the drive must receive a leading edge from the start input for the drive to start after a stop input, loss of power or fault condition.

Options	0	“Keypad” (Default)	<ul style="list-style-type: none"> • Integral keypad controls drive operation. • I/O Terminal 1 “Stop” = Coast-to-stop. • When active, the Reverse key is also active unless disabled by A095 [Reverse Disable].
	1	“3-wire”	I/O Terminal 1 “Stop” = Stop according to the value set in P037 [Stop Mode].
	2	“2-wire”	I/O Terminal 1 “Stop” = Coast-to-stop.
	3	“2-W Lvl Sens”	Drive will restart after a “Stop” command when: <ul style="list-style-type: none"> • Stop is removed <li style="padding-left: 20px;">and • Start is held active



ATTENTION: Hazard of injury exists due to unintended operation. When P036 [Start Source] is set to option 3, and the Run input is maintained, the Run inputs do not need to be toggled after a Stop input for the drive to run again. A Stop function is provided only when the Stop input is active (open).

4	“2-W Hi Speed”	<p>Important: There is greater potential voltage on the output terminals when using this option.</p> <ul style="list-style-type: none"> • Outputs are kept in a ready-to-run state. The drive will respond to a “Start” command within 10 ms. • I/O Terminal 1 “Stop” = Coast-to-stop.
5	“Comm Port”	<ul style="list-style-type: none"> • Remote communications. See Appendix C for details. • I/O Terminal 1 “Stop” = Coast-to-stop.
6	“Momt FWD/REV”	<ul style="list-style-type: none"> • Drive will start after a momentary input from either the Run FWD Input (I/O Terminal 02) or the Run REV Input (I/O Terminal 03). • I/O Terminal 1 “Stop” = Coast-to-stop.

Basic Program Group *(continued)*

P037 [Stop Mode]

Related Parameters: [P036](#), [A080](#), [A081](#), [A082](#), [A105](#), [A160](#)

Active stop mode for all stop sources [for example keypad, run forward (I/O Terminal 02), run reverse (I/O Terminal 03), RS-485 port] except as noted below.

Important: I/O Terminal 01 is always a coast to stop input except when [P036](#) [Start Source] is set for “3-wire” control. When in three wire control, I/O Terminal 01 is controlled by [P037](#) [Stop Mode].

Hardware Enable Circuitry

By default, I/O Terminal 01 is a coast to stop input. The status of the input is interpreted by drive software. If the application requires the drive to be disabled without software interpretation, a “dedicated” hardware enable configuration can be utilized. This is accomplished by removing the ENBL enable jumper on the control board. In this case, the drive will always coast to a stop regardless of the settings of [P036](#) [Start Source] and [P037](#) [Stop Mode].

Options	0	“Ramp, CF” ⁽¹⁾ (Default)	Ramp to Stop. “Stop” command clears active fault.
	1	“Coast, CF” ⁽¹⁾	Coast to Stop. “Stop” command clears active fault.
	2	“DC Brake, CF” ⁽¹⁾	DC Injection Braking Stop. “Stop” command clears active fault.
	3	“DCBrkAuto, CF” ⁽¹⁾	DC Injection Braking Stop with Auto Shutoff. <ul style="list-style-type: none"> • Standard DC Injection Braking for value set in A080 [DC Brake Time]. OR • Drive shuts off if the drive detects that the motor is stopped. “Stop” command clears active fault.
	4	“Ramp”	Ramp to Stop.
	5	“Coast”	Coast to Stop.
	6	“DC Brake”	DC Injection Braking Stop.
	7	“DC BrakeAuto”	DC Injection Braking Stop with Auto Shutoff. <ul style="list-style-type: none"> • Standard DC Injection Braking for value set in A080 [DC Brake Time]. OR • Drive shuts off if current limit is exceeded.
	8	“Ramp+EM B, CF”	Ramp to Stop with EM Brake Control. “Stop” Command clears active fault.
	9	“Ramp+EM Brk”	Ramp to Stop with EM Brake Control.

⁽¹⁾ Stop input also clears active fault.

Basic Program Group *(continued)*

P038 [Speed Reference] Related Parameters: [d001, d002, d012, d020, d021, P039, P040, A051...A054, A069, A070...A077, A110...A113, A123, A132, A140...A147, A150...A157](#)

Sets the source of the speed reference to the drive.

The drive speed command can be obtained from a number of different sources. The source is normally determined by [P038](#) [Speed Reference]. However, when [A051...A054](#) [Digital Inx Sel] is set to option 2, 4, 5, 6, 11, 12, 13, 14, 15, and the digital input is active, or if [A132](#) [PID Ref Sel] is not set to option 0, the speed reference commanded by [P038](#) [Speed Reference] will be overridden. See the flowchart on [page 33](#) for more information on speed reference control priority.

Options	0	“Drive Pot” (Default)	Frequency command from the potentiometer on the integral keypad. Important: This option is not available with IP66, NEMA/UL Type 4X rated drives. Internal frequency command comes from A069 [Internal Freq].
	1	“InternalFreq” (IP66, NEMA/UL Type 4X Default)	Internal frequency command from A069 [Internal Freq]. Must be set when using MOP function.
	2	“0-10V Input”	External frequency command from the 0...10V or ±10V analog input or remote potentiometer.
	3	“4-20mA Input”	External frequency command from the 4...20 mA analog input.
	4	“Preset Freq”	External frequency command as defined by A070...A077 [Preset Freq x] when A051...A054 [Digital Inx Sel] are programmed as “Preset Frequencies” and the digital inputs are active.
	5	“Comm Port”	External frequency command from the communications port. See Appendix C for details.
	6	“Stp Logic”	External frequency command as defined by A070...A077 [Preset Freq x] and A140...A147 [Stp Logic x].
	7	“Anlg In Mult”	External frequency command as defined by the product of the analog inputs (shown in d020 [Analog In 0-10V] and d021 [Analog In 4-20mA]). [Analog In 0-10V] × [Analog In 4-20mA] = Speed Command Example: 100% × 50% = 50%

P039 [Accel Time 1] Related Parameters: [P038, P040, A051...A054, A067, A070...A077, A140...A147](#)

Sets the rate of acceleration for all speed increases.

$$\frac{\text{Maximum Freq}}{\text{Accel Time}} = \text{Accel Rate}$$

Values	Default:	10.0 Secs
	Min/Max:	0.0/600.0 Secs
	Display:	0.1 Secs

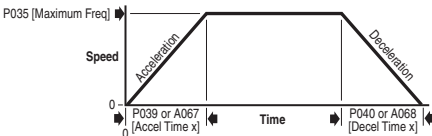

Basic Program Group *(continued)*

P040 [Decel Time 1]

Related Parameters: [P038](#), [P039](#), [A051...A054](#),
[A068](#), [A070...A077](#), [A140...A147](#)

Sets the rate of deceleration for all speed decreases.

$$\frac{\text{Maximum Freq}}{\text{Decel Time}} = \text{Decel Rate}$$

Values	Default:	10.0 Secs
	Min/Max:	0.1/600.0 Secs
	Display:	0.1 Secs

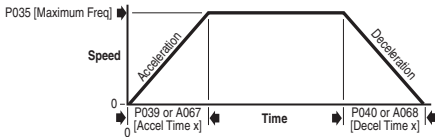

P041 [Reset To Defaults]



Stop drive before changing this parameter.

Resets all parameter values to factory defaults.

Options 0 "Ready/Idle" (Default)

1 "Factory Rset"

- After the reset function is complete, this parameter will set itself back to "0".
- Causes an F48 [Params Defaulted](#) fault.

P042 [Voltage Class]



Stop drive before changing this parameter.

Sets the voltage class of 600V drives.

Options	2 "Low Voltage"	480V
	3 "High Voltage" (Default)	600V

P043 [Motor OL Ret]

Related Parameters: [P033](#)

Enables/disables the Motor Overload Retention function. When Enabled, the value held in the motor overload counter is saved at power-down and restored at power-up. A change to this parameter setting resets the counter.

Options	0 "Disabled" (Default)
	1 "Enabled"

Advanced Program Group

A051 [Digital In1 Sel]
(I/O Terminal 05)

Related Parameters: [d012](#), [d014](#), [P038](#), [P039](#), [P040](#), [A067](#),
[A068](#), [A070](#)...[A077](#), [A078](#), [A079](#), [A118](#), [A140](#)...[A147](#)

A052 [Digital In2 Sel]
(I/O Terminal 06)

A053 [Digital In3 Sel]
(I/O Terminal 07)



Stop drive before changing this parameter.

A054 [Digital In4 Sel]
(I/O Terminal 08)

Selects the function for the digital inputs. See the flowchart on [Start and Speed Reference Control on page 33](#) for more information on speed reference control priority.

Options	0 “Not Used”	Terminal has no function but can be read over network communications via d014 [Dig In Status].
	1 “Acc & Dec 2”	<ul style="list-style-type: none"> When active, A067 [Accel Time 2] and A068 [Decel Time 2] are used for all ramp rates except Jog. Can only be tied to one input. <p>See the flowchart on page 34 for more information on Accel/Decel selection.</p>
	2 “Jog”	<ul style="list-style-type: none"> When input is present, drive accelerates according to the value set in A079 [Jog Accel/Decel] and ramps to the value set in A078 [Jog Frequency]. When input is removed, drive ramps to a stop according to the value set in A079 [Jog Accel/Decel]. A valid “Start” command will override this input.
	3 “Aux Fault”	When enabled, an F2 Auxiliary Input fault will occur when the input is removed.
	4 “Preset Freq” (A051 & A052 Default)	See A070 ... A077 [Preset Freq x]. Important: Digital Inputs have priority for frequency control when programmed as Preset Speed and are active. See the flowchart on page 33 for more information on speed reference control priority.
	5 “Local” (A053 Default)	When active, sets integral keypad as start source and potentiometer on the integral keypad as speed source. Important: Speed source for IP66, NEMA/UL Type 4X rated drives comes from A069 [Internal Freq].
	6 “Comm Port”	<ul style="list-style-type: none"> When active, sets communications device as default start/speed command source. Can only be tied to one input.
	7 “Clear Fault”	When active, clears an active fault.
	8 “RampStop,CF”	Causes drive to immediately ramp to a stop regardless of how P037 [Stop Mode] is set.
	9 “CoastStop,CF”	Causes drive to immediately coast to a stop regardless of how P037 [Stop Mode] is set.
	10 “DCInjStop,CF”	Causes drive to immediately begin a DC Injection stop regardless of how P037 [Stop Mode] is set.
	11 “Jog Forward” (A054 Default)	Drive accelerates to A078 [Jog Frequency] according to A079 [Jog Accel/Decel] and ramps to stop when input becomes inactive. A valid start will override this command.
	12 “Jog Reverse”	Drive accelerates to A078 [Jog Frequency] according to A079 [Jog Accel/Decel] and ramps to stop when input becomes inactive. A valid start will override this command.

A051...A054 Options (Cont.)	13	“10V In Ctrl”	Selects 0...10V or ±10V control as the frequency reference. Start source is not changed.
	14	“20mA In Ctrl”	Selects 4...20 mA control as the frequency reference. Start source is not changed.
	15	“PID Disable”	Disables PID function. Drive uses the next valid non-PID speed reference.
	16	“MOP Up”	Increases the value of A069 [Internal Freq] at the current Accel rate if P038 [Speed Reference] is set to 1 “InternalFreq”. For IP20 rated drives, the default for A069 is 60.0 Hz. For IP66, NEMA/UL Type 4X drives, the default for A069 is 0.0 Hz.
	17	“MOP Down”	Decreases the value of A069 [Internal Freq] at the current Decel rate if P038 [Speed Reference] is set to 1 “InternalFreq”. For IP20 rated drives, the default for A069 is 60.0 Hz. For IP66, NEMA/UL Type 4X drives, the default for A069 is 0.0 Hz.
	18	“Timer Start”	Clears and starts the timer function. May be used to control the relay or opto outputs.
	19	“Counter In”	Starts the counter function. May be used to control the relay or opto outputs.
	20	“Reset Timer”	Clears the active timer.
	21	“Reset Countr”	Clears the active counter.
	22	“Rset Tim&Cnt”	Clears the active timer and counter.
	23	“Logic In1”	Logic function input number 1. May be used to control the relay or opto outputs (see parameters A055 , A058 , A061 Options 11...14). May be used in conjunction with StepLogic parameters A140 ... A147 [Stp Logic x].
	24	“Logic In2”	Logic function input number 2. May be used to control the relay or opto outputs (see parameters A055 , A058 , A061 Options 11...14). May be used in conjunction with StepLogic parameters A140 ... A147 [Stp Logic x].
	25	“Current Lmt2”	When active, A118 [Current Limit 2] determines the drive current limit level.
	26	“Anlg Invert”	Inverts the scaling of the analog input levels set in A110 [Anlg In 0-10V Lo] and A111 [Anlg In 0-10V Hi] or A112 [Anlg In4-20mA Lo] and A113 [Anlg In4-20mA Hi].
27	“EM Brk Rlse”	If EM brake function is enabled, this input releases the brake.	



ATTENTION: If a hazard of injury due to movement of equipment or material exists, an auxiliary mechanical braking device must be used.

Advanced Program Group *(continued)*

A055 [Relay Out Sel]

Related Parameters: [P033](#), [A056](#), [A092](#), [A140...A147](#),
[A150...A157](#),
[A160](#), [A161](#)

Sets the condition that changes the state of the output relay contacts.

Options	0	“Ready/Fault” (Default)	Relay changes state when power is applied. This indicates that the drive is ready for operation. Relay returns drive to shelf state when power is removed or a fault occurs.
	1	“At Frequency”	Drive reaches commanded frequency.
	2	“MotorRunning”	Motor is receiving power from the drive.
	3	“Reverse”	Drive is commanded to run in reverse direction.
	4	“Motor Overld”	Motor overload condition exists.
	5	“Ramp Reg”	Ramp regulator is modifying the programmed accel/deccl times to avoid an overcurrent or overvoltage fault from occurring.
	6	“Above Freq”	<ul style="list-style-type: none"> Drive exceeds the frequency (Hz) value set in A056 [Relay Out Level]. Use A056 to set threshold.
	7	“Above Cur”	<ul style="list-style-type: none"> Drive exceeds the current (% Amps) value set in A056 [Relay Out Level]. Use A056 to set threshold. <p>Important: Value for A056 [Relay Out Level] must be entered in percent of drive rated output current.</p>
	8	“Above DCVolt”	<ul style="list-style-type: none"> Drive exceeds the DC bus voltage value set in A056 [Relay Out Level]. Use A056 to set threshold.
	9	“Retries Exst”	Value set in A092 [Auto Rstrt Tries] is exceeded.
	10	“Above Anlg V”	<ul style="list-style-type: none"> Analog input voltage (I/O Terminal 13) exceeds the value set in A056 [Relay Out Level]. Do not use if A123 [10V Bipolar Enbl] is set to 1 “Bi-Polar In”. This parameter setting can also be used to indicate a PTC trip point when the input (I/O Terminal 13) is wired to a PTC and external resistor. Use A056 to set threshold.
	11	“Logic In 1”	An input is programmed as “Logic In 1” and is active.
	12	“Logic In 2”	An input is programmed as “Logic In 2” and is active.
	13	“Logic 1 & 2”	Both Logic inputs are programmed and active.
	14	“Logic 1 or 2”	One or both Logic inputs are programmed and one or both is active.
	15	“StpLogic Out”	Drive enters StepLogic step with Digit 3 of Command Word (A140...A147) set to enable StepLogic output.
	16	“Timer Out”	<ul style="list-style-type: none"> Timer has reached value set in A056 [Relay Out Level]. Use A056 to set threshold.
	17	“Counter Out”	<ul style="list-style-type: none"> Counter has reached value set in A056 [Relay Out Level]. Use A056 to set threshold.
	18	“Above PF Ang”	<ul style="list-style-type: none"> Power Factor angle has exceeded the value set in A056 [Relay Out Level]. Use A056 to set threshold.

A055 Options (Cont.)	19 “Anlg In Loss”	Analog input loss has occurred. Program A122 [Analog In Loss] for desired action when input loss occurs.
	20 “ParamControl”	Prior to FRN 4.01, this option enables the output to be controlled over network communications by writing to A056 [Relay Out Level]. (0 = Off, 1 = On) With FRN 4.01 and later, the logic command word bit 15 has full control of A056 . See Writing (06) Logic Command Data on page 126 .
	21 “NonRec Fault”	<ul style="list-style-type: none"> Value set in A092 [Auto Rstrt Tries] is exceeded. A092 [Auto Rstrt Tries] in not enabled. A Non-resettable fault has occurred.
	22 “EM Brk Cntrl”	EM brake is energized. Program A160 [EM Brk Off Delay] and A161 [EM Brk On Delay] for desired action.
	23 “Above Fcmd”	The current commanded frequency exceeds the value set in A056 [Relay Out Level].
	24 “MsgControl”	With FRN 4.01 and later, this option enables the output to be controlled over network communications by writing to A056 [Relay Out Level]. (0 = Off, 1 = On.)

A056 [Relay Out Level]

Related Parameters: [A055](#)



32-bit parameter.

Sets the trip point for the digital output relay if the value of [A055](#) [Relay Out Sel] is 6, 7, 8, 10, 16, 17, 18, or 20.

With firmware revision 4.01 and later, when the value of [A055](#) is set to 20, the logic command word bit 15 has full control of A056.

A055 Setting	A056 Min/Max
6	0/400 Hz
7	0/180%
8	0/815 Volts
10	0/100%
16	0.1/9999 Secs
17	1/9999 Counts
18	1/180 degs
20	0/1
23	0/400 Hz

Values	Default:	0.0
	Min/Max:	0.0/9999
	Display:	0.1

Advanced Program Group *(continued)*

A058 [Opto Out1 Sel]

Related Parameters: [P033](#), [A059](#), [A062](#), [A092](#), [A122](#), [A123](#),

A061 [Opto Out2 Sel]

[A160](#), [A161](#), [A140...A147](#), [A150...A157](#)

Determines the operation of the programmable opto outputs.

Options		
0	“Ready/Fault”	Opto outputs are active when power is applied. This indicates that the drive is ready for operation. Opto outputs are inactive when power is removed or a fault occurs.
1	“At Frequency” (A061 Default)	Drive reaches commanded frequency.
2	“MotorRunning” (A058 Default)	Motor is receiving power from the drive.
3	“Reverse”	Drive is commanded to run in reverse direction.
4	“Motor Overld”	Motor overload condition exists.
5	“Ramp Reg”	Ramp regulator is modifying the programmed accel/decel times to avoid an overcurrent or overvoltage fault from occurring.
6	“Above Freq”	<ul style="list-style-type: none"> Drive exceeds the frequency (Hz) value set in A059 or A062 [Opto Outx Level]. Use A059 or A062 to set threshold.
7	“Above Cur”	<ul style="list-style-type: none"> Drive exceeds the current (% Amps) value set in A059 or A062 [Opto Outx Level]. Use A059 or A062 to set threshold. <p>Important: Value for A059 or A062 [Opto Outx Level] must be entered in percent of drive rated output current.</p>
8	“Above DCVolt”	<ul style="list-style-type: none"> Drive exceeds the DC bus voltage value set in A059 or A062 [Opto Outx Level]. Use A059 or A062 to set threshold.
9	“Retries Exst”	Value set in A092 [Auto Rstrt Tries] is exceeded.
10	“Above Anlg V”	<ul style="list-style-type: none"> Analog input voltage (I/O Terminal 13) exceeds the value set in A059 or A062 [Opto Outx Level]. Do not use if A123 [10V Bipolar Enbl] is set to 1 “Bi-Polar In”. This parameter setting can also be used to indicate a PTC trip point when the input (I/O Terminal 13) is wired to a PTC and external resistor. Use A059 or A062 to set threshold.
11	“Logic In 1”	An input is programmed as “Logic In 1” and is active.
12	“Logic In 2”	An input is programmed as “Logic In 2” and is active.
13	“Logic 1 & 2”	Both Logic inputs are programmed and active.
14	“Logic 1 or 2”	One or both Logic inputs are programmed and one or both is active.
15	“StpLogic Out”	Drive enters StepLogic step with Digit 3 of Command Word (A140...A147) set to enable StepLogic output.
16	“Timer Out”	<ul style="list-style-type: none"> Timer has reached value set in A059 or A062 [Opto Outx Level]. Use A059 or A062 to set threshold.
17	“Counter Out”	<ul style="list-style-type: none"> Counter has reached value set in A059 or A062 [Opto Outx Level]. Use A059 or A062 to set threshold.

A058, A061 Options (Cont.)	18 “Above PF Ang”	<ul style="list-style-type: none"> Power Factor angle has exceeded the value set in A059 or A062 [Opto Outx Level]. Use A059 or A062 to set threshold.
	19 “Anlg In Loss”	Analog input loss has occurred. Program A122 [Analog In Loss] for desired action when input loss occurs.
	20 “ParamControl”	<p>Prior to FRN 4.01, this option enables the output to be controlled over network communications by writing to A059 or A062 [Opto Outx Level]. (0 = Off, 1 = On)</p> <p>With FRN 4.01 and later:</p> <p>Setting this option for A058 means the logic command word bit 6 has full control of A059.</p> <p>Setting this option for A059 means the logic command word bit 7 has full control of A062.</p> <p>See Writing (06) Logic Command Data on page 126.</p>
	21 “NonRec Fault”	<ul style="list-style-type: none"> Value set in A092 [Auto Rstrt Tries] is exceeded. A092 [Auto Rstrt Tries] in not enabled. A Non-resettable fault has occurred.
	22 “EM Brk Cntrl”	EM brake is energized. Program A160 [EM Brk Off Delay] and A161 [EM Brk On Delay] for desired action.
	23 “Above Fcmd”	The current commanded frequency exceeds the value set in A059 or A062 [Opto Outx Level].
	24 “MsgControl”	<p>With FRN 4.01 and later:</p> <p>Enables the output to be controlled over the network communications by writing to A059 or A062 [Opto Outx Level]. (0 = Off, 1 = On)</p>

A059 [Opto Out1 Level]

Related Parameters: [A058](#), [A061](#)

A062 [Opto Out2 Level]



32-bit parameter.

Determines the on/off point for the opto outputs when [A058](#) or [A061](#) [Opto Outx Sel] is set to option 6, 7, 8, 10, 16, 17, 18, or 20.

With FRN 4.01 and later, when the value of A058 is set to 20, the logic command word bit 6 has full control of A059 and when the value of A061 is set to 20, bit 7 has full control of A062.

A058 & A061 Setting	A059 & A062 Min/Max
6	0/400 Hz
7	0/180%
8	0/815 Volts
10	0/100%
16	0.1/9999 Secs
17	1/9999 Counts
18	1/180 degs
20	0/1
23	0/400 Hz

Values	Default:	0.0
	Min/Max:	0.0/9999
	Display:	0.1

Advanced Program Group *(continued)*

A064 [Opto Out Logic]

Determines the logic (Normally Open/NO or Normally Closed/NC) of the opto outputs.

A064 Option	Opto Out1 Logic	Opto Out2 Logic
0	NO (Normally Open)	NO (Normally Open)
1	NC (Normally Closed)	NO (Normally Open)
2	NO (Normally Open)	NC (Normally Closed)
3	NC (Normally Closed)	NC (Normally Closed)

Values	Default:	0
	Min/Max:	0/3
	Display:	1

A065 [Analog Out Sel]

Related Parameters: [P035](#), [A066](#)

Sets the analog output signal mode (0...10V, 0...20 mA, or 4...20 mA). The output is used to provide a signal that is proportional to several drive conditions.

Option	Output Range	Minimum Output Value	Maximum Output Value A066 [Analog Out High]	DIP Switch Position	Related Parameter
0 "OutFreq 0-10"	0...10V	0V = 0 Hz	P035 [Maximum Freq]	0...10V	d001
1 "OutCurr 0-10"	0...10V	0V = 0 Amps	200% Drive Rated Output Current	0...10V	d003
2 "OutVolt 0-10"	0...10V	0V = 0 Volts	120% Drive Rated Output Volts	0...10V	d004
3 "OutPowr 0-10"	0...10V	0V = 0 kW	200% Drive Rated Power	0...10V	d022
4 "TstData 0-10"	0...10V	0V = 0000	65535 (Hex FFFF)	0...10V	d019
5 "OutFreq 0-20"	0...20 mA	0 mA = 0 Hz	P035 [Maximum Freq]	0...20 mA	d001
6 "OutCurr 0-20"	0...20 mA	0 mA = 0 Amps	200% Drive Rated Output Current	0...20 mA	d003
7 "OutVolt 0-20"	0...20 mA	0 mA = 0 Volts	120% Drive Rated Output Volts	0...20 mA	d004
8 "OutPowr 0-20"	0...20 mA	0 mA = 0 kW	200% Drive Rated Power	0...20 mA	d022
9 "TstData 0-20"	0...20 mA	0 mA = 0000	65535 (Hex FFFF)	0...20 mA	d019
10 "OutFreq 4-20"	4...20 mA	4 mA = 0 Hz	P035 [Maximum Freq]	0...20 mA	d001
11 "OutCurr 4-20"	4...20 mA	4 mA = 0 Amps	200% Drive Rated Output Current	0...20 mA	d003
12 "OutVolt 4-20"	4...20 mA	4 mA = 0 Volts	120% Drive Rated Output Volts	0...20 mA	d004
13 "OutPowr 4-20"	4...20 mA	4 mA = 0 kW	200% Drive Rated Power	0...20 mA	d022
14 "TstData 4-20"	4...20 mA	4 mA = 0000	65535 (Hex FFFF)	0...20 mA	d019
15 "OutTorq 0-10"	0...10V	0V = 0 Amps	200% Drive Rated FLA	0...10V	d029
16 "OutTorq 0-20"	0...20 mA	0 mA = 0 Amps	200% Drive Rated FLA	0...20 mA	d029
17 "OutTorq 4-20"	4...20 mA	4 mA = 0 Amps	200% Drive Rated FLA	0...20 mA	d029
18 "Setpnt 0-10"	0...10V	0V = 0%	100.0% Setpoint Setting	0...10V	A109
19 "Setpnt 0-20"	0...20 mA	0 mA = 0%	100.0% Setpoint Setting	0...20 mA	A109
20 "Setpnt 4-20"	4...20 mA	4 mA = 0%	100.0% Setpoint Setting	0...20 mA	A109
21 "MinFreq 0-10"	0...10V	0V = Min. Freq	P035 [Maximum Freq]	0...10V	d001
22 "MinFreq 0-20"	0...20 mA	0 mA = Min. Freq	P035 [Maximum Freq]	0...20 mA	d001
23 "MinFreq 4-20"	4...20 mA	4 mA = Min. Freq	P035 [Maximum Freq]	0...20 mA	d001

Values	Default:	0
	Min/Max:	0/23
	Display:	1

Advanced Program Group *(continued)*

A066 [Analog Out High]

Related Parameters: [A065](#)

Scales the Maximum Output Value for the [A065](#) [Analog Out Sel] source setting.

Examples:

A066 Setting	A065 Setting	A065 Max. Output Value
50%	1 "OutCurr 0-10"	5V for 200% Drive Rated Output Current
90%	8 "OutPowr 0-20"	18 mA for 200% Drive Rated Power

Values	Default:	100%
	Min/Max:	0/800%
	Display:	1%

A067 [Accel Time 2]

Related Parameters: [P039](#), [A051...A054](#), [A070...A077](#), [A140...A147](#)

When active, sets the rate of acceleration for all speed increases except jog. See the flowchart on [page 34](#) for details.

$$\frac{\text{Maximum Freq}}{\text{Accel Time}} = \text{Accel Rate}$$

Values	Default:	20.0 Secs
	Min/Max:	0.0/600.0 Secs
	Display:	0.1 Secs

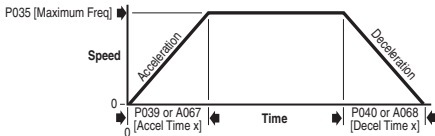

Advanced Program Group *(continued)*

A068 [Decel Time 2]

Related Parameters: [P040](#), [A051...A054](#), [A070...A077](#), [A140...A147](#)

When active, sets the rate of deceleration for all speed decreases except jog. See the flowchart on [page 34](#) for details.

$$\frac{\text{Maximum Freq}}{\text{Decel Time}} = \text{Decel Rate}$$

Values	Default:	20.0 Secs
	Min/Max:	0.1/600.0 Secs
	Display:	0.1 Secs

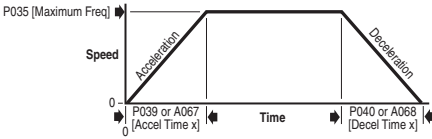

A069 [Internal Freq]

Related Parameters: [P038](#), [A162](#)

Provides the frequency command to the drive when [P038](#) [Speed Reference] is set to 1 "Internal Freq". When enabled, this parameter will change the frequency command in "real time" using the integral keypad Up Arrow or Down Arrow when in program mode.

Important: Once the desired command frequency is reached, the Enter key must be pressed to store this value to EEPROM memory. If the ESC key is used before the Enter key, the frequency will return to the original value following the normal accel/decel curve.

If [A051... A054](#) [Digital Inx Sel] is set to 16 "MOP Up" or 17 "MOP Down" this parameter acts as the MOP frequency reference.

Values	Default:	60.0 Hz for IP20 rated drives 0.0 Hz for IP66, NEMA/UL Type 4X drives
	Min/Max:	0.0/400.0 Hz
	Display:	0.1 Hz

Advanced Program Group *(continued)*

- A070** [Preset Freq 0]⁽¹⁾
- A071** [Preset Freq 1]
- A072** [Preset Freq 2]
- A073** [Preset Freq 3]
- A074** [Preset Freq 4]
- A075** [Preset Freq 5]
- A076** [Preset Freq 6]
- A077** [Preset Freq 7]

Related Parameters: [P038, P039, P040, A051...A053, A067, A068, A140...A147, A150...A157](#)

Values	A070 Default: ⁽¹⁾	0.0 Hz
	A071 Default:	5.0 Hz
	A072 Default:	10.0 Hz
	A073 Default:	20.0 Hz
	A074 Default:	30.0 Hz
	A075 Default:	40.0 Hz
	A076 Default:	50.0 Hz
	A077 Default:	60.0 Hz
	Min/Max:	0.0/400.0 Hz
	Display:	0.1 Hz

Provides a fixed frequency command value when [A051...A053](#) [Digital Inx Sel] is set to 4 "Preset Frequencies". An active preset input will override speed command as shown in the flowchart on [page 33](#).

(1) To activate A070 [Preset Freq 0] set [P038](#) [Speed Reference] to option 4 "Preset Freq 0-3".

Input State of Digital In 1 (I/O Terminal 05 when A051 = 4)	Input State of Digital In 2 (I/O Terminal 06 when A052 = 4)	Input State of Digital In 3 (I/O Terminal 07 when A053 = 4)	Frequency Source	Accel / Decel Parameter Used ⁽²⁾
0	0	0	A070 [Preset Freq 0]	[Accel Time 1] / [Decel Time 1]
1	0	0	A071 [Preset Freq 1]	[Accel Time 1] / [Decel Time 1]
0	1	0	A072 [Preset Freq 2]	[Accel Time 2] / [Decel Time 2]
1	1	0	A073 [Preset Freq 3]	[Accel Time 2] / [Decel Time 2]
0	0	1	A074 [Preset Freq 4]	[Accel Time 1] / [Decel Time 1]
1	0	1	A075 [Preset Freq 5]	[Accel Time 1] / [Decel Time 1]
0	1	1	A076 [Preset Freq 6]	[Accel Time 2] / [Decel Time 2]
1	1	1	A077 [Preset Freq 7]	[Accel Time 2] / [Decel Time 2]

(2) When a Digital Input is set to "Accel 2 & Decel 2", and the input is active, that input overrides the settings in this table.

A078 [Jog Frequency]

Related Parameters: [P035, A051...A054, A079](#)

Sets the output frequency when a jog command is issued.

Values	Default:	10.0 Hz
	Min/Max:	0.0/[Maximum Freq]
	Display:	0.1 Hz

Advanced Program Group *(continued)*

A079 [Jog Accel/Decel]

Related Parameters: [A078](#), [A051](#)...[A054](#)

Sets the acceleration and deceleration time when a jog command is issued.

Values	Default:	10.0 Secs
	Min/Max:	0.1/600.0 Secs
	Display:	0.1 Secs

A080 [DC Brake Time]

Related Parameters: [P037](#), [A081](#)

Sets the length of time that DC brake current is "injected" into the motor. See parameter [A081](#) [DC Brake Level].

Values	Default:	0.0 Secs
	Min/Max:	0.0/99.9 Secs (A setting of 99.9 = Continuous)
	Display:	0.1 Secs

A081 [DC Brake Level]

Related Parameters: [P037](#), [A080](#)

Defines the maximum DC brake current, in amps, applied to the motor when [P037](#) [Stop Mode] is set to either "Ramp" or "DC Brake".

Values	Default:	Drive Rated Amps \times 0.05
	Min/Max:	0.0/(Drive Rated Amps \times 1.8)
	Display:	0.1 Amps

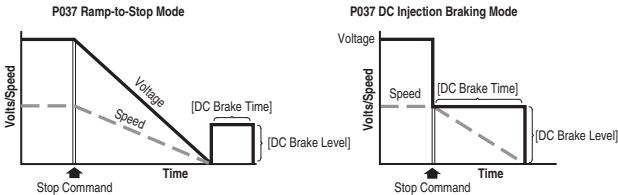

ATTENTION: If a hazard of injury due to movement of equipment or material exists, an auxiliary mechanical braking device must be used.



ATTENTION: This feature should not be used with synchronous or permanent magnet motors. Motors may be demagnetized during braking.

Advanced Program Group *(continued)*

A082 [DB Resistor Sel]

Related Parameters: [P037](#)



Stop drive before changing this parameter.

Enables/disables external dynamic braking.

Setting	Min/Max
0	"Disabled"
1	"Normal RA Res" (5% Duty Cycle) – See Table 3 .
2	"NoProtection" (100% Duty Cycle)
3-99	"x%Duty Cycle" Limited (3% – 99% of Duty Cycle)

The drive is able to provide full braking indefinitely. Braking power is limited by the external DB resistor. When this parameter is set to 1 "Normal RA Res" and an appropriate resistor is used (see selection [Table 3](#)), the drive provides calculated resistor overload protection. However, the drive cannot protect against a brake IGBT failure.



ATTENTION: A risk of fire exists if external braking resistors are not protected. The external resistor package must be self-protected from over temperature or the protective circuit shown in [Figure 9](#), or equivalent, must be supplied.

Values	Default:	0
	Min/Max:	0/99
	Display:	1

A083 [S Curve %]

Sets the percentage of acceleration or deceleration time that is applied to the ramp as S Curve. Time is added, 1/2 at the beginning and 1/2 at the end of the ramp.

Values	Default:	0% (Disabled)
	Min/Max:	0/100%
	Display:	1%

Example:

Accel Time = 10 Seconds
 S Curve Setting = 50%
 S Curve Time = $10 \times 0.5 = 5$ Seconds
 Total Time = $10 + 5 = 15$ Seconds

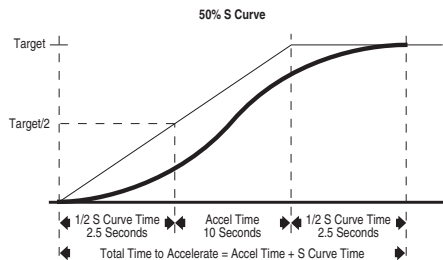

Advanced Program Group *(continued)*

A084 [Boost Select]

Related Parameters: [d004](#), [P031](#), [P032](#), [A085](#), [A086](#), [A087](#), [A125](#)

Sets the boost voltage (% of [P031](#) [Motor NP Volts]) and redefines the Volts per Hz curve.

Active when A125 [Torque Perf Mode] = 0 "V/Hz".

Drive may add additional voltage unless Option 5 is selected.

Options	0	"Custom V/Hz"
	1	"30.0, VT" Variable Torque (Typical fan/pump curves.)
	2	"35.0, VT"
	3	"40.0, VT"
	4	"45.0, VT"
	5	"0.0 no IR" Constant Torque
	6	"0.0"
	7	"2.5, CT" [Default for 4.0, 5.5, 7.5 & 11 kW (5.0, 7.5, 10 & 15 HP Drives)]
	8	"5.0, CT" (Default)
	9	"7.5, CT"
	10	"10.0, CT"
	11	"12.5, CT"
	12	"15.0, CT"
	13	"17.5, CT"
	14	"20.0, CT"

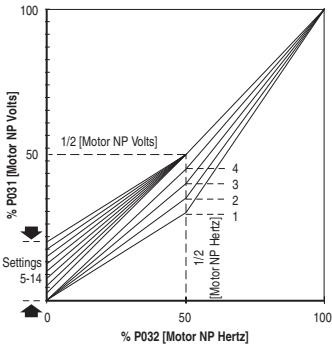

Advanced Program Group *(continued)*

A085 [Start Boost]

Related Parameters: [P031](#), [P032](#), [P034](#), [P035](#),
[A084](#), [A086](#), [A087](#), [A088](#), [A125](#)

Sets the boost voltage (% of [P031](#) [Motor NP Volts]) and redefines the Volts per Hz curve when A084 [Boost Select] = 0 "Custom V/Hz" and A125 [Torque Perf Mode] = 0 "V/Hz".

Drive may add additional voltage unless Option 5 is selected.

Values	Default:	2.5%
	Min/Max:	0.0/25.0%
	Display:	0.1%

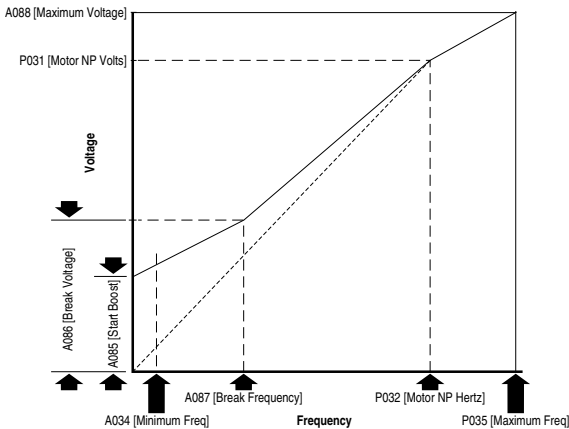

A086 [Break Voltage]

Related Parameters: [P031](#), [P032](#), [P034](#), [P035](#),
[A084](#), [A085](#), [A087](#), [A088](#), [A125](#)

Sets the frequency where break voltage is applied when A084 [Boost Select] = 0 "Custom V/Hz" and A125 [Torque Perf Mode] = 0 "V/Hz"

Values	Default:	25.0%
	Min/Max:	0.0/100.0%
	Display:	0.1%

A087 [Break Frequency]

Related Parameters: [P031](#), [P032](#), [P034](#), [P035](#),
[A084](#), [A085](#), [A086](#), [A088](#), [A125](#)

Sets the frequency where break frequency is applied when A084 [Boost Select] = 0 "Custom V/Hz" and A125 [Torque Perf Mode] = 0 "V/Hz"

Values	Default:	15.0 Hz
	Min/Max:	0.0/400.0 Hz
	Display:	0.1 Hz

Advanced Program Group *(continued)*

A088 [Maximum Voltage]

Related Parameters: [d004](#), [A085](#), [A086](#), [A087](#)

Sets the highest voltage the drive will output.

Values	Default:	Drive Rated Volts
	Min/Max:	20/Drive Rated Volts
	Display:	1 VAC

A089 [Current Limit 1]

Related Parameters: [P033](#), [A118](#)

Maximum output current allowed before current limiting occurs.

Values	Default:	Drive Rated Amps × 1.5
	Min/Max:	0.1/Drive Rated Amps × 1.8
	Display:	0.1 Amps

A090 [Motor OL Select]

Related Parameters: [P032](#), [P033](#)

Drive provides Class 10 motor overload protection. Settings 0...2 select the derating factor for the I²t overload function.

Options	0 "No Derate" (Default)
	1 "Min Derate"
	2 "Max Derate"

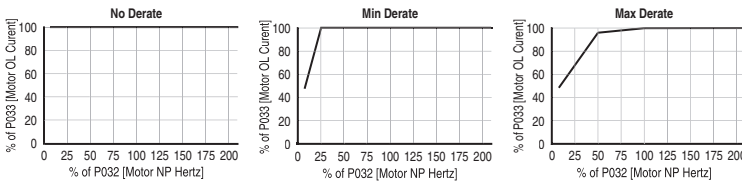

A091 [PWM Frequency]

Related Parameters: [A124](#)

Sets the carrier frequency for the PWM output waveform. The chart below provides derating guidelines based on the PWM frequency setting.

Important: Ignoring derating guidelines can cause reduced drive performance.

Values	Default:	4.0 kHz
	Min/Max:	2.0/16.0 kHz
	Display:	0.1 kHz

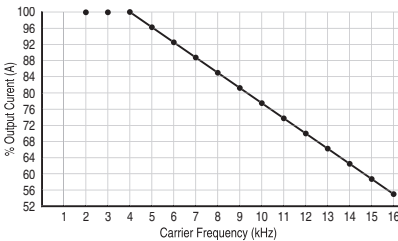

Advanced Program Group *(continued)*

A092 [Auto Rstrt Tries]

Related Parameters: [A055](#), [A058](#), [A061](#), [A093](#)

Sets the maximum number of times the drive attempts to reset a fault and restart.

Clear a Type 1 fault and restart the drive.

1. Set A092 [Auto Rstrt Tries] to a value other than "0".
2. Set [A093](#) [Auto Rstrt Delay] to a value other than "0".

Clear an OverVoltage, UnderVoltage or Heatsink OvrTmp fault without restarting the drive.

1. Set A092 [Auto Rstrt Tries] to a value other than "0".
2. Set [A093](#) [Auto Rstrt Delay] to "0".



ATTENTION: Equipment damage and/or personal injury may result if this parameter is used in an inappropriate application. Do not use this function without considering applicable local, national and international codes, standards, regulations or industry guidelines.

Values	Default:	0
	Min/Max:	0/9
	Display:	1

A093 [Auto Rstrt Delay]

Related Parameters: [A092](#)

Sets the time between restart attempts when [A092](#) [Auto Rstrt Tries] is set to a value other than zero.

Values	Default:	1.0 Secs
	Min/Max:	0.0/300.0 Secs
	Display:	0.1 Secs

A094 [Start At PowerUp]



Stop drive before changing this parameter.

Enables/disables a feature that allows a Start or Run command to automatically cause the drive to resume running at commanded speed after drive input power is restored. Requires a digital input configured for Run or Start and a valid start contact.

This parameter will not function if parameter [P036](#) [Start Source] is set to 4 "2-W High Speed".



ATTENTION: Equipment damage and/or personal injury may result if this parameter is used in an inappropriate application. Do not use this function without considering applicable local, national and international codes, standards, regulations or industry guidelines.

Options	0	"Disabled" (Default)
	1	"Enabled"

Advanced Program Group *(continued)*

A095 [Reverse Disable]

Related Parameters: [d006](#)



Stop drive before changing this parameter.

Enables/disables the function that allows the direction of motor rotation to be changed. The reverse command may come from a digital command, the keypad or a serial command. All reverse inputs including two-wire Run Reverse will be ignored with reverse disabled.

Options	0	“Rev Enabled” (Default)
	1	“Rev Disabled”

A096 [Flying Start En]

Sets the condition that allows the drive to reconnect to a spinning motor at actual RPM.

Options	0	“Disabled” (Default)
	1	“Enabled”

A097 [Compensation]

Enables/disables correction options that may improve problems with motor instability.

Options	0	“Disabled”	
	1	“Electrical” (Default)	Some drive/motor combinations have inherent instabilities which are exhibited as non-sinusoidal motor currents. This setting attempts to correct this condition.
	2	“Mechanical”	Some motor/load combinations have mechanical resonances which can be excited by the drive current regulator. This setting slows down the current regulator response and attempts to correct this condition.
	3	“Both”	

A098 [SW Current Trip]

Related Parameters: [P033](#)

Enables/disables a software instantaneous (within 100 ms) current trip.

Values	Default:	0.0 (Disabled)
	Min/Max:	0.0/(Drive Rated Amps × 2)
	Display:	0.1 Amps

A099 [Process Factor]

Related Parameters: [d010](#)

Scales the output frequency value displayed by [d010](#) [Process Display].

$$\text{Output Freq} \times \text{Process Factor} = \text{Process Display}$$

Values	Default:	30.0
	Min/Max:	0.1/999.9
	Display:	0.1

Advanced Program Group *(continued)*

A100 [Fault Clear]



Stop drive before changing this parameter.

Resets a fault and clears the fault queue. Used primarily to clear a fault over network communications.

Options	0	“Ready/Idle” (Default)	
	1	“Reset Fault”	
	2	“Clear Buffer”	(Parameters d007... d009 [Fault x Code])

A101 [Program Lock]

Protects parameters against change by unauthorized personnel.

Options	0	“Unlocked” (Default)
	1	“Locked”

A102 [Testpoint Sel]

Related Parameters: [d019](#)

Used by Rockwell Automation field service personnel.

Values	Default:	400
	Min/Max:	0/FFFF
	Display:	1 Hex

A103 [Comm Data Rate]

Related Parameters: [d015](#)

Sets the serial port rate for the RS-485 (DSI) port.

Important: Power to drive must be cycled before any changes will affect drive operation.

Options	0	“1200”
	1	“2400”
	2	“4800”
	3	“9600” (Default)
	4	“19.2K”
	5	“38.4K”

A104 [Comm Node Addr]

Related Parameters: [d015](#)

Sets the drive node address for the RS-485 (DSI) port if using a network connection.

Important: Power to drive must be cycled before any changes will affect drive operation.

Values	Default:	100
	Min/Max:	1/247
	Display:	1

Advanced Program Group *(continued)*

A105 [Comm Loss Action] Related Parameters: [d015](#), [P037](#), [A106](#)

Selects the drive's response to a loss of the communication connection or excessive communication errors.

Options	0	"Fault" (Default)	Drive will fault on an F81 Comm Loss and coast to stop.
	1	"Coast Stop"	Stops drive via coast to stop.
	2	"Stop"	Stops drive via P037 [Stop Mode] setting.
	3	"Continu Last"	Drive continues operating at communication commanded speed saved in RAM.

A106 [Comm Loss Time] Related Parameters: [d015](#), [A105](#)

Sets the time that the drive will remain in communication loss before implementing the option selected in [A105](#) [Comm Loss Action].

Values	Default:	5.0 Secs
	Min/Max:	0.1/60.0 Secs
	Display:	0.1 Secs

A107 [Comm Format] Related Parameters: [d015](#)

Selects the protocol (RTU only), data bits (8 data bits only), parity (None, Even, Odd), and stop bits (1 stop bit only) used by the RS-485 port on the drive.

See [Appendix C](#) for details on using the drive communication features.

Important: Power to drive must be cycled before any changes will affect drive operation.

Options	0	"RTU 8-N-1" (Default)
	1	"RTU 8-E-1"
	2	"RTU 8-O-1"
	3	"RTU 8-N-2"
	4	"RTU 8-E-2"
	5	"RTU 8-O-2"

A108 [Language]

Selects the language displayed by the remote communications option.

Options	1	"English" (Default)
	2	"Français"
	3	"Español"
	4	"Italiano"
	5	"Deutsch"
	6	"Reserved"
	7	"Português"
	8	"Reserved"
	9	"Reserved"
	10	"Nederlands"

Advanced Program Group *(continued)*

A109 [Anlg Out Setpt]

Related Parameters: [A065](#)

When A065 [Analog Out Sel] is set to option 18, 19, or 20, this parameter sets the percentage of analog output desired.

Values	Default:	0.0%
	Min/Max:	0.0/100.0%
	Display:	0.1%

A110 [Anlg In 0-10V Lo]

Related Parameters: [d020](#), [P034](#), [P038](#), [A122](#)

Sets the analog input level that corresponds to P034 [Minimum Freq] if a 0...10V input is used by P038 [Speed Reference].

Analog inversion can be accomplished by setting this value larger than A111 [Anlg In 0-10V Hi].

Values	Default:	0.0%
	Min/Max:	0.0/100.0%
	Display:	0.1%

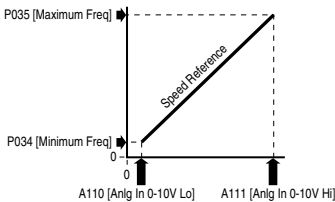

A111 [Anlg In 0-10V Hi]

Related Parameters: [d020](#), [P035](#), [P038](#), [A122](#), [A123](#)

Sets the analog input level that corresponds to P035 [Maximum Freq] if a 0...10V input is used by P038 [Speed Reference].

Analog inversion can be accomplished by setting this value smaller than A110 [Anlg In 0-10V Lo].

Values	Default:	100.0%
	Min/Max:	0.0/100.0%
	Display:	0.1%

A112 [Anlg In4-20mA Lo]

Related Parameters: [d021](#), [P034](#), [P038](#)

Sets the analog input level that corresponds to P034 [Minimum Freq] if a 4...20 mA input is used by [P038](#) [Speed Reference].

Analog inversion can be accomplished by setting this value larger than A113 [Anlg In4-20mA Hi].

Values	Default:	0.0%
	Min/Max:	0.0/100.0%
	Display:	0.1%

Advanced Program Group *(continued)*

A113 [Anlg In4-20mA Hi] Related Parameters: [d021](#), [P035](#), [P038](#)

Sets the analog input level that corresponds to [P035](#) [Maximum Freq] if a 4...20 mA input is used by [P038](#) [Speed Reference].

Analog inversion can be accomplished by setting this value smaller than A112 [Anlg In4-20mA Lo].

Values	Default:	100.0%
	Min/Max:	0.0/100.0%
	Display:	0.1%

A114 [Slip Hertz @ FLA] Related Parameters: [P033](#)

Compensates for the inherent slip in an induction motor. This frequency is added to the commanded output frequency based on motor current.

Values	Default:	2.0 Hz
	Min/Max:	0.0/10.0 Hz
	Display:	0.1 Hz

A115 [Process Time Lo] Related Parameters: [d010](#), [P034](#)

Scales the time value when the drive is running at [P034](#) [Minimum Freq]. When set to a value other than zero, [d010](#) [Process Display] indicates the duration of the process.

Values	Default:	0.00
	Min/Max:	0.00/99.99
	Display:	0.01

A116 [Process Time Hi] Related Parameters: [d010](#), [P035](#)

Scales the time value when the drive is running at [P035](#) [Maximum Freq]. When set to a value other than zero, [d010](#) [Process Display] indicates the duration of the process.

Values	Default:	0.00
	Min/Max:	0.00/99.99
	Display:	0.01

A117 [Bus Reg Mode]

Controls the operation of the drive voltage regulation, which is normally operational at decel or when the bus voltage rises.

See the Attention statement on [page 9](#) for important information on bus regulation.

Options	0	“Disabled”
	1	“Enabled” (Default)

A118 [Current Limit 2] Related Parameters: [P033](#), [A051...A054](#), [A089](#)

Maximum output current allowed before current limiting occurs. This parameter is only active if [A051...A054](#) [Digital Inx Sel] is set to 25 “Current Lmt2” and is active.

Values	Default:	Drive Rated Amps × 1.5
	Min/Max:	0.1/(Drive Rated Amps × 1.8)
	Display:	0.1 Amps

Advanced Program Group *(continued)*

A119 [Skip Frequency]

Related Parameters: [A120](#)

Sets the frequency at which the drive will not operate.
A setting of 0 disables this parameter.

Values	Default:	0 Hz
	Min/Max:	0/400 Hz
	Display:	1 Hz

A120 [Skip Freq Band]

Related Parameters: [A119](#)

Determines the bandwidth around [A119](#) [Skip Frequency]. A120 [Skip Frequency Band] is split applying 1/2 above and 1/2 below the actual skip frequency.

A setting of 0.0 disables this parameter.

Values	Default:	0.0 Hz
	Min/Max:	0.0/30.0 Hz
	Display:	0.1 Hz

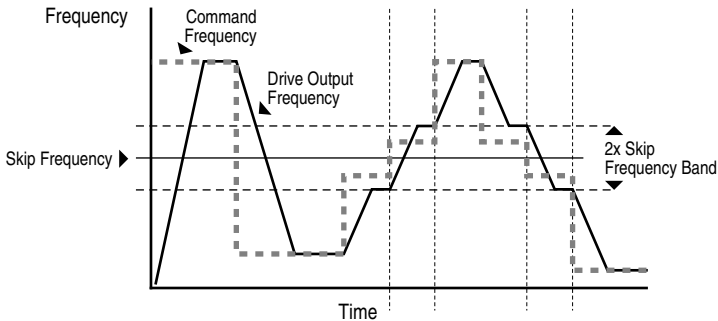

A121 [Stall Fault Time]

Sets the time that the drive will remain in stall mode before a fault is issued.

Options	0	“60 Seconds” (Default)
	1	“120 Seconds”
	2	“240 Seconds”
	3	“360 Seconds”
	4	“480 Seconds”
	5	“Fit Disabled”

Advanced Program Group *(continued)*

A122 [Analog In Loss]

Related Parameters: [A110](#), [A111](#), [A132](#)

Selects drive action when an input signal loss is detected. Signal loss is defined as an analog signal less than 1V or 2 mA. The signal loss event ends and normal operation resumes when the input signal level is greater than or equal to 1.5V or 3 mA. If using a 0...10V analog input, set [A110](#) [Anlg In 0-10V Lo] to a minimum of 20% (for instance 2 volts).

Options	0	“Disabled” (Default)	
	1	“Fault (F29)”	F29 Analog Input Loss
	2	“Stop”	Uses P037 [Stop Mode]
	3	“Zero Ref”	Drive runs at zero speed reference.
	4	“Min Freq Ref”	Drive runs at minimum frequency.
	5	“Max Freq Ref”	Drive runs at maximum frequency.
	6	“Int Freq Ref”	Drive runs at internal frequency.

A123 [10V Bipolar Enbl]

Related Parameters: [P038](#), [A111](#)

Enables/disables bipolar control. In bipolar mode direction is commanded by the sign of the reference.

Options	0	“Uni-Polar In” (Default)	0 to 10V only
	1	“Bi-Polar In”	±10V

A124 [Var PWM Disable]

Related Parameters: [A091](#)



Stop drive before changing this parameter.

Enables/disables a feature that varies the carrier frequency for the PWM output waveform defined by [A091](#) [PWM Frequency].

Disabling this feature when low frequency conditions exist may result in IGBT stress and nuisance tripping.

Options	0	“Enabled” (Default)
	1	“Disabled”

A125 [Torque Perf Mode]

Related Parameters: [A084](#), [A085](#), [A086](#), [A087](#), [A127](#)



Stop drive before changing this parameter.

Enables/disables sensorless vector control operation.

Options	0	“V/Hz”
	1	“Sensrls Vect” (Default)

A126 [Motor NP FLA]

Related Parameters: [A127](#)

Set to the motor nameplate rated full load amps.

Values	Default:	Drive Rated Amps
	Min/Max:	0.1/(Drive Rated Amps × 2)
	Display:	0.1 Amps

Advanced Program Group *(continued)*

A127 [Autotune]

Related Parameters: [A125](#), [A126](#), [A128](#), [A129](#)



Stop drive before changing this parameter.

Provides an automatic method for setting A128 [IR Voltage Drop] and A129 [Flux Current Ref], which affect sensorless vector performance. Parameter [A126](#) [Motor NP FLA] must be set to the motor nameplate full load amps before running the Autotune procedure.

Options	0	“Ready/Idle” (Default)
	1	“Static Tune”
	2	“Rotate Tune”

“Ready” (0) = Parameter returns to this setting following a “Static Tune” or “Rotate Tune.”

“Static Tune” (1) = A temporary command that initiates a non-rotational motor stator resistance test for the best possible automatic setting of [A128](#) [IR Voltage Drop]. A start command is required following initiation of this setting. The parameter returns to “Ready” (0) following the test, at which time another start transition is required operate the drive in normal mode. Used when motor cannot be uncoupled from the load.

“Rotate Tune” (2) = A temporary command that initiates a “Static Tune” followed by a rotational test for the best possible automatic setting of [A129](#) [Flux Current Ref]. A start command is required following initiation of this setting. The parameter returns to “Ready” (0) following the test, at which time another start transition is required to operate the drive in normal mode. **Important:** Used when motor is uncoupled from the load. Results may not be valid if a load is coupled to the motor during this procedure.



ATTENTION: Rotation of the motor in an undesired direction can occur during this procedure. To guard against possible injury and/or equipment damage, it is recommended that the motor be disconnected from the load before proceeding.

If the Autotune routine fails, an F80 SVC Autotune fault is displayed.

A128 [IR Voltage Drop]

Related Parameters: [A127](#)

Value of volts dropped across the resistance of the motor stator.

Values	Default:	Based on Drive Rating
	Min/Max:	0.0/230.0 VAC
	Display:	0.1 VAC

A129 [Flux Current Ref]

Related Parameters: [A127](#)

Value of amps for full motor flux.

Values	Default:	Based on Drive Rating
	Min/Max:	0.00/[Motor NP FLA]
	Display:	0.01 Amps

Advanced Program Group *(continued)*

A130 [PID Trim Hi]

Sets the maximum positive value that is added to the speed reference when PID trim is used.

Values	Default:	60.0
	Min/Max:	0.0/400.0
	Display:	0.1

A131 [PID Trim Lo]

Sets the maximum positive value that is subtracted from the PID reference when PID trim is used.

Values	Default:	0.0
	Min/Max:	0.0/400.0
	Display:	0.1

A132 [PID Ref Sel]

Related Parameters: [P038](#), [A122](#)



Stop drive before changing this parameter.

Enables/disables PID mode and selects the source of the PID reference. See [Appendix F](#) for details.

Options	0	“PID Disabled” (Default)
	1	“PID Setpoint”
	2	“0-10V Input”
	3	“4-20mA Input”
	4	“Comm Port”
	5	“Setpnt, Trim”
	6	“0-10V, Trim”
	7	“4-20mA, Trim”
8	“Comm, Trim”	

A133 [PID Feedback Sel]

Select the source of the PID feedback. See [Appendix F](#) for details.

Options	0	“0-10V Input” (Default)	The PID will not function with a bipolar input. Negative voltages are treated as 0 volts.
	1	“4-20mA Input”	
	2	“Comm Port”	

A134 [PID Prop Gain]

Sets the value for the PID proportional component when the PID mode is enabled by [A132](#) [PID Ref Sel].

Values	Default:	0.01
	Min/Max:	0.00/99.99
	Display:	0.01

Advanced Program Group *(continued)*

A135 [PID Integ Time]

Sets the value for the PID integral component when the PID mode is enabled by [A132](#) [PID Ref Sel].

Values	Default:	0.1 Secs
	Min/Max:	0.0/999.9 Secs
	Display:	0.1 Secs

A136 [PID Diff Rate]

Sets the value for the PID differential component when the PID mode is enabled by [A132](#) [PID Ref Sel].

Values	Default:	0.01 (1/Secs)
	Min/Max:	0.00/99.99 (1/Secs)
	Display:	0.01 (1/Secs)

A137 [PID Setpoint]

Provides an internal fixed value for process setpoint when the PID mode is enabled by [A132](#) [PID Ref Sel].

Values	Default:	0.0%
	Min/Max:	0.0/100.0%
	Display:	0.1%

A138 [PID Deadband]

Sets the lower limit of the PID output.

Values	Default:	0.0%
	Min/Max:	0.0/10.0%
	Display:	0.1%

A139 [PID Preload]

Sets the value used to preload the integral component on start or enable.

Values	Default:	0.0 Hz
	Min/Max:	0.0/400.0 Hz
	Display:	0.1 Hz

Advanced Program Group *(continued)*

A140	[Stp Logic 0]	Related Parameters: P038 , P039 , P040 , A051...A054 , A055 , A058 , A061 , A067 , A068 , A070...A077 , A150...A157
A141	[Stp Logic 1]	
A142	[Stp Logic 2]	
A143	[Stp Logic 3]	
A144	[Stp Logic 4]	
A145	[Stp Logic 5]	
A146	[Stp Logic 6]	
A147	[Stp Logic 7]	

 Stop drive before changing this parameter.

Values	Default:	00F1
	Min/Max:	0001/bAFF
	Display:	4 Digits

Parameters A140...A147 are only active if [P038](#) [Speed Reference] is set to 6 "Stp Logic".

These parameters can be used to create a custom profile of frequency commands. Each "step" can be based on time, status of a Logic input or a combination of time and the status of a Logic input.

Digits 0...3 for each [Stp Logic x] parameter must be programmed according to the desired profile.

A Logic input is established by setting a digital input, parameters [A051...A054](#) [Digital Inx Sel], to 23 "Logic In1" and/or 24 "Logic In2".

A time interval between steps can be programmed using parameters [A150...A157](#) [Stp Logic Time x]. See the table below for related parameters.

The speed for any step is programmed using parameters [A070...A077](#) [Preset Freq x].

StepLogic Parameter (Active when P038 = 6 "Stp Logic")	Related Preset Frequency Parameter (Can be activated independent of StepLogic Parameters)	Related StepLogic Time Parameter (Active when A140...A147 Digit 0 or 1 are set to 1, b, C, d, or E)
A140 [Stp Logic 0]	A070 [Preset Freq 0]	A150 [Stp Logic Time 0]
A141 [Stp Logic 1]	A071 [Preset Freq 1]	A151 [Stp Logic Time 1]
A142 [Stp Logic 2]	A072 [Preset Freq 2]	A152 [Stp Logic Time 2]
A143 [Stp Logic 3]	A073 [Preset Freq 3]	A153 [Stp Logic Time 3]
A144 [Stp Logic 4]	A074 [Preset Freq 4]	A154 [Stp Logic Time 4]
A145 [Stp Logic 5]	A075 [Preset Freq 5]	A155 [Stp Logic Time 5]
A146 [Stp Logic 6]	A076 [Preset Freq 6]	A156 [Stp Logic Time 6]
A147 [Stp Logic 7]	A077 [Preset Freq 7]	A157 [Stp Logic Time 7]

How StepLogic Works

The StepLogic sequence begins with a valid start command. A normal sequence always begins with A140 [Stp Logic 0].

Digit 0: Logic For Next Step

This digit defines the logic for the next step. When the condition is met the program advances to the next step. Step 0 follows Step 7. Example: Digit 0 is set 3. When "Logic In2" becomes active, the program advances to the next step.

Digit 1: Logic to Jump to a Different Step

For all settings other than F, when the condition is met, the program overrides Digit 0 and jumps to the step defined by Digit 2.

Digit 2: Different Step to Jump

When the condition for Digit 1 is met, the Digit 2 setting determines the next step or to end the program.

Digit 3: Step Settings

This digit defines what accel/decel profile the speed command will follow and the direction of the command for the current step. In addition, if a relay or opto output (parameters [A055](#), [A058](#), and [A061](#)) is set to 15 "StpLogic Out", this parameter can control the status of that output.

Any StepLogic parameter can be programmed to control a relay or opto output, but you can not control different outputs based on the condition of different StepLogic commands.

StepLogic Settings

The logic for each function is determined by the four digits for each StepLogic parameter. The following is a listing of the available settings for each digit.

See [Appendix E](#) for details.

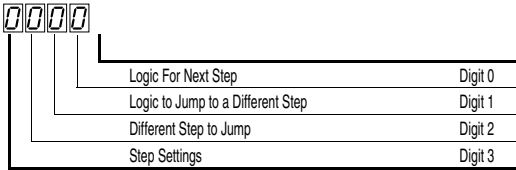

Digit 3 Settings

Required Setting	Accel/Decel Param. Used	StepLogic Output State	Commanded Direction
0	Accel/Decel 1	Off	FWD
1	Accel/Decel 1	Off	REV
2	Accel/Decel 1	Off	No Output
3	Accel/Decel 1	On	FWD
4	Accel/Decel 1	On	REV
5	Accel/Decel 1	On	No Output
6	Accel/Decel 2	Off	FWD
7	Accel/Decel 2	Off	REV
8	Accel/Decel 2	Off	No Output
9	Accel/Decel 2	On	FWD
A	Accel/Decel 2	On	REV
b	Accel/Decel 2	On	No Output

Digit 2 Settings

- 0 = Jump to Step 0
- 1 = Jump to Step 1
- 2 = Jump to Step 2
- 3 = Jump to Step 3
- 4 = Jump to Step 4
- 5 = Jump to Step 5
- 6 = Jump to Step 6
- 7 = Jump to Step 7
- 8 = End Program (Normal Stop)
- 9 = End Program (Coast to Stop)
- A = End Program and Fault (F2)

Digit 1 and Digit 0 Settings

- 0 = Skip Step (Jump Immediately)
- 1 = Step Based on [Stp Logic Time x]
- 2 = Step if "Logic In1" is Active
- 3 = Step if "Logic In2" is Active
- 4 = Step if "Logic In1" is Not Active
- 5 = Step if "Logic In2" is Not Active
- 6 = Step if either "Logic In1" or "Logic In2" is Active
- 7 = Step if both "Logic In1" and "Logic In2" is Active
- 8 = Step if neither "Logic In1" or "Logic In2" is Active
- 9 = Step if "Logic In1" is Active and "Logic In2" is Not Active
- A = Step if "Logic In2" is Active and "Logic In1" is Not Active
- b = Step after [Stp Logic Time x] and "Logic In1" is Active
- C = Step after [Stp Logic Time x] and "Logic In2" is Active
- d = Step after [Stp Logic Time x] and "Logic In1" is Not Active
- E = Step after [Stp Logic Time x] and "Logic In2" is Not Active
- F = Do Not Step/Ignore Digit 2 Settings

Advanced Program Group *(continued)*

A161 [EM Brk On Delay]

Related Parameters: [P037](#)

Sets the time the drive remains at minimum frequency before the relay or an opto output is de-energizing and the drive stops.

The relay or opto output is typically connected to a user-supplied electromechanical brake coil relay.

Set [P037](#) [Stop Mode] to 8 "Ramp+EM B,CF" or 9 "Ramp+EM Brk" to enable the electromechanical brake option.

Set [A055](#) [Relay Out Sel], [A058](#) or [A061](#) [Opto Outx Sel] to 22 "EM Brk Cntrl" to control brake operation.

Values	Default:	2.00 Secs
	Min/Max:	0.01/10.00 Secs
	Display:	0.01 Secs

A162 [MOP Reset Sel]

Related Parameters: [A069](#)

Set the drive to save the current MOP reference command.

Options	0 "Zero MOP Ref"	This option clamps A069 [Internal Freq] at 0.0 Hz when the drive is not running.
	1 "Save MOP Ref" (Default)	Reference is saved in A069 [Internal Freq].

A163 [DB Threshold]

Related Parameters: [P037](#), [A080](#), [A081](#), [A082](#)

Sets the DC bus Voltage Threshold for Dynamic Brake operation. If the DC bus voltage falls below the value set in this parameter, the Dynamic Brake will not turn on. Lower values will make the Dynamic Braking function more responsive but may result in nuisance Dynamic Brake activation.

Values	Default	100.0%
	Min/Max:	0.0/110.0%
	Display:	0.0%



ATTENTION: Equipment damage may result if this parameter is set a value that causes the dynamic braking resistor to dissipate excessive power. Parameter settings less than 100% should be carefully evaluated to ensure that the dynamic brake resistor's wattage rating is not exceeded. In general, values less than 90% are not needed. This parameter's setting is especially important if parameter [A082](#) [DB Resistor Sel] is set to 2 "No Protection".

Advanced Program Group *(continued)*

A164 [Comm Write Mode]

Determines whether parameter changes made over communication port are saved and stored in Non-volatile Storage (NVS) or RAM only. If they are stored in RAM, the values will be lost at power-down.

Options	0	"Save" (Default)
	1	"RAM Only"



ATTENTION: Risk of equipment damage exists. If a controller is programmed to write parameter data to Non-volatile Storage (NVS) frequently, the NVS will quickly exceed its life cycle and cause the drive to malfunction. Do not create a program that frequently uses configurable outputs to write parameter data to NVS unless A164 [Comm Write Mode] is set to option 1.

A165 [Anlg Loss Delay]

Related Parameters: [A122](#)

Sets the length of time after power-up during which the drive will not detect an analog signal loss. The drive response to an analog signal loss is set in [A122](#) [Analog In Loss].

Values	Default:	0.0 Secs
	Min/Max:	0.0/20.0 Secs
	Display:	0.1 Secs

A166 [Analog In Filter]

Sets level of additional filtering of the analog input signals. A higher number increases filtering and decreases bandwidth. Each setting doubles the applied filtering (1 = 2x filter, 2 = 4x filter, and so on). No additional filtering is applied when set to "0".

Values	Default:	0
	Min/Max:	0/14
	Display:	1

A167 [PID Invert Error]

When set to "Inverted", changes the sign of the PID error. This causes an increase in the drive output frequency with PID Feedback greater than PID Setpoint, and a decrease in drive output frequency with PID Feedback less than PID Setpoint.

Options	0	"Not Inverted" (Default)
	1	"Inverted"

Parameter Cross Reference – by Name

Parameter Name	Number	Group	Parameter Name	Number	Group
10V Bipolar Enbl	A123	Advanced Program	Maximum Voltage	A088	Advanced Program
Accel Time 1	P039	Basic Program	Minimum Freq	P034	Basic Program
Accel Time 2	A067	Advanced Program	MOP Reset Sel	A162	Advanced Program
Analog In 0-10V	d020	Display	Motor NP FLA	A126	Advanced Program
Analog In 4-20mA	d021	Display	Motor NP Hertz	P032	Basic Program
Analog In Filter	A166	Advanced Program	Motor NP Volts	P031	Basic Program
Analog In Loss	A122	Advanced Program	Motor OL Current	P033	Basic Program
Analog Out High	A066	Advanced Program	Motor OL Ret	P043	Basic Program
Analog Out Sel	A065	Advanced Program	Motor OL Select	A090	Advanced Program
Anlg In 0-10V Hi	A111	Advanced Program	Opto Out Logic	A064	Advanced Program
Anlg In 0-10V Lo	A110	Advanced Program	Opto Outx Level	A059 , A062	Advanced Program
Anlg In4-20mA Hi	A113	Advanced Program	Opto Outx Sel	A058 , A061	Advanced Program
Anlg In4-20mA Lo	A112	Advanced Program	Output Current	d003	Display
Anlg Loss Delay	A166	Advanced Program	Output Freq	d001	Display
Anlg Out Setpt	A109	Advanced Program	Output Power	d022	Display
Auto Rstrl Delay	A093	Advanced Program	Output Powr Fctr	d023	Display
Auto Rstrl Tries	A092	Advanced Program	Output Voltage	d004	Display
Autotune	A127	Advanced Program	PID Deadband	A138	Advanced Program
Boost Select	A084	Advanced Program	PID Diff Rate	A136	Advanced Program
Break Frequency	A087	Advanced Program	PID Feedback Sel	A133	Advanced Program
Break Voltage	A086	Advanced Program	PID Integ Time	A135	Advanced Program
Bus Reg Mode	A117	Advanced Program	PID Invert Error	A167	Advanced Program
Comm Data Rate	A103	Advanced Program	PID Preload	A139	Advanced Program
Comm Format	A107	Advanced Program	PID Prop Gain	A134	Advanced Program
Comm Loss Action	A105	Advanced Program	PID Ref Sel	A132	Advanced Program
Comm Loss Time	A106	Advanced Program	PID Setpoint	A137	Advanced Program
Comm Node Addr	A104	Advanced Program	PID Trim Hi	A130	Advanced Program
Comm Status	d015	Display	PID Trim Lo	A131	Advanced Program
Comm Write Mode	A164	Advanced Program	Preset Freq x	A070 ... A077	Advanced Program
Commanded Freq	d002	Display	Process Display	d010	Display
Compensation	A097	Advanced Program	Process Factor	A099	Advanced Program
Contrl In Status	d013	Display	Process Time Hi	A116	Advanced Program
Control Source	d012	Display	Process Time Lo	A115	Advanced Program
Control SW Ver	d016	Display	Program Lock	A101	Advanced Program
Counter Status	d025	Display	PWM Frequency	A091	Advanced Program
Current Limit x	A089 , A118	Advanced Program	Relay Out Level	A056	Advanced Program
DB Resistor Sel	A082	Advanced Program	Relay Out Sel	A055	Advanced Program
DB Threshold	A163	Advanced Program	Reset To Defaults	P041	Basic Program
DC Brake Level	A081	Advanced Program	Reverse Disable	A095	Advanced Program
DC Brake Time	A080	Advanced Program	S Curve %	A083	Advanced Program
DC Bus Voltage	d005	Display	Skip Freq Band	A120	Advanced Program
Decel Time 1	P040	Basic Program	Skip Frequency	A119	Advanced Program
Decel Time 2	A068	Advanced Program	Slip Hertz @ FLA	A114	Advanced Program
Dig In Status	d014	Display	Stp Logic Status	d028	Display
Digital Inx Sel	A051 ... A054	Advanced Program	Stp Logic x	A140 ... A147	Advanced Program
Drive Status	d006	Display	Stp Logic Time x	A150 ... A157	Advanced Program
Drive Temp	d024	Display	Speed Reference	P038	Basic Program
Drive Type	d017	Display	Stall Fault Time	A121	Advanced Program
Elapsed Run Time	d018	Display	Start At PowerUp	A094	Advanced Program
EM Brk Off Delay	A160	Advanced Program	Start Boost	A085	Advanced Program
EM Brk On Delay	A161	Advanced Program	Start Source	P036	Basic Program
Fault Clear	A100	Advanced Program	Stop Mode	P037	Basic Program
Fault x Code	d007 ... d009	Display	SW Current Trip	A098	Advanced Program
Flux Current Ref	A129	Advanced Program	Testpoint Data	d019	Display
Flying Start En	A096	Advanced Program	Testpoint Sel	A102	Advanced Program
Internal Freq	A069	Advanced Program	Timer Status	d026	Display
IR Voltage Drop	A128	Advanced Program	Torque Current	d029	Display
Jog Accel/Decel	A079	Advanced Program	Torque Perf Mode	A125	Advanced Program
Jog Frequency	A078	Advanced Program	Var PWM Disable	A124	Advanced Program
Language	A108	Advanced Program	Voltage Class	P042	Basic Program
Maximum Freq	P035	Basic Program			

Notes:

Troubleshooting

Chapter 4 provides information to guide you in troubleshooting the PowerFlex 40 drive. Included is a listing and description of drive faults (with possible solutions, when applicable).

Drive Status

The condition or state of your drive is constantly monitored. Any changes will be indicated through the integral keypad.

LED Indications

See [page 40](#) for information on drive status indicators and controls.

Faults

A fault is a condition that stops the drive. There are two fault types.

Type	Fault Description
①	Auto-reset/Run When this type of fault occurs, and A092 [Auto Rstrt Tries] is set to a value greater than "0," a user-configurable timer, A093 [Auto Rstrt Delay], begins. When the timer reaches zero, the drive attempts to automatically reset the fault. If the condition that caused the fault is no longer present, the fault will be reset and the drive will be restarted.
②	Non-resetable This type of fault may require drive or motor repair, or is caused by wiring or programing errors. The cause of the fault must be corrected before the fault can be cleared.

Fault Indication

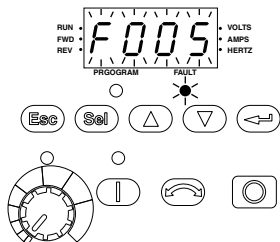
Condition	Display
<p>Drive is indicating a fault.</p> <p>The integral keypad provides visual notification of a fault condition by displaying the following.</p> <ul style="list-style-type: none"> • Flashing fault number • Flashing fault indicator <p>Press the Escape key to regain control of the integral keypad.</p>	

Manually Clearing Faults

Step	Key(s)
<ol style="list-style-type: none"> 1. Press Esc to acknowledge the fault. The fault information will be removed so that you can use the integral keypad. Access d007 [Fault 1 Code] to view the most recent fault information. 2. Address the condition that caused the fault. The cause must be corrected before the fault can be cleared. See Table 10. 3. After corrective action has been taken, clear the fault by one of these methods. <ul style="list-style-type: none"> • Press Stop if P037 [Stop Mode] is set to a value between “0” and “3”. • Cycle drive power. • Set A100 [Fault Clear] to “1” or “2”. • Cycle digital input if A051...A054 [Digital Inx Sel] is set to option 7 “Clear Fault”. 	

Automatically Clearing Faults

Option / Step
<p>Clear a Type 1 fault and restart the drive.</p> <ol style="list-style-type: none"> 1. Set A092 [Auto Rstrt Tries] to a value other than “0”. 2. Set A093 [Auto Rstrt Delay] to a value other than “0”. <p>Clear an OverVoltage, UnderVoltage or Heatsink OvrTmp fault without restarting the drive.</p> <ol style="list-style-type: none"> 1. Set A092 [Auto Rstrt Tries] to a value other than “0”. 2. Set A093 [Auto Rstrt Delay] to “0”.

Auto Restart (Reset/Run)

The Auto Restart feature provides the ability for the drive to automatically perform a fault reset followed by a start attempt without user or application intervention. This allows remote or “unattended” operation. Only certain faults are allowed to be reset. Certain faults (Type 2) that indicate possible drive component malfunction are not resettable.

Caution should be used when enabling this feature, since the drive will attempt to issue its own start command based on user selected programming.

Fault Descriptions

Table 10 – Fault Types, Descriptions, and Actions

No.	Fault	Type ⁽¹⁾	Description	Action
F2	Auxiliary Input	①	Auxiliary input interlock is open.	<ol style="list-style-type: none"> 1. Check remote wiring. 2. Verify communications programming for intentional fault.
F3	Power Loss	②	Excessive DC Bus voltage ripple.	<ol style="list-style-type: none"> 1. Monitor the incoming line for phase loss or line imbalance. 2. Check input line fuse.
F4	UnderVoltage	①	DC bus voltage fell below the minimum value.	Monitor the incoming AC line for low voltage or line power interruption.
F5	OverVoltage	①	DC bus voltage exceeded maximum value.	Monitor the AC line for high line voltage or transient conditions. Bus overvoltage can also be caused by motor regeneration. Extend the decel time or install dynamic brake option.
F6	Motor Stalled	①	Drive is unable to accelerate motor.	Increase P039...A067 [Accel Time x] or reduce load so drive output current does not exceed the current set by parameter A089 [Current Limit 1].
F7	Motor Overload	①	Internal electronic overload trip.	<ol style="list-style-type: none"> 1. An excessive motor load exists. Reduce load so drive output current does not exceed the current set by parameter P033 [Motor OL Current]. 2. Verify A084 [Boost Select] setting
F8	Heatsink OvrTmp	①	Heatsink temperature exceeds a predefined value.	<ol style="list-style-type: none"> 1. Check for blocked or dirty heat sink fins. Verify that ambient temperature has not exceeded 40 °C (104 °F) for IP30, NEMA UL Type 1 installations or 50 °C (122 °F) for IP20/Open type installations. 2. Check fan.
F12	HW OverCurrent	②	The drive output current has exceeded the hardware current limit.	Check programming. Check for excess load, improper A084 [Boost Select] setting, DC brake volts set too high or other causes of excess current.
F13	Ground Fault	②	A current path to earth ground has been detected at one or more of the drive output terminals.	Check the motor and external wiring to the drive output terminals for a grounded condition.
F29	Analog Input Loss	①	An analog input is configured to fault on signal loss. A signal loss has occurred. Configure with A122 [Analog In Loss].	<ol style="list-style-type: none"> 1. Check parameters. 2. Check for broken/loose connections at inputs.

Chapter 4 Troubleshooting

Table 10 – Fault Types, Descriptions, and Actions (Continued)

No.	Fault	Type ⁽¹⁾	Description	Action
F33	Auto Rstrt Tries	②	Drive unsuccessfully attempted to reset a fault and resume running for the programmed number of A092 [Auto Rstrt Tries].	Correct the cause of the fault and manually clear.
F38	Phase U to Gnd	②	A phase to ground fault has been detected between the drive and motor in this phase.	<ol style="list-style-type: none"> 1. Check the wiring between the drive and motor. 2. Check motor for grounded phase. 3. Replace drive if fault cannot be cleared.
F39	Phase V to Gnd			
F40	Phase W to Gnd			
F41	Phase UV Short	②	Excessive current has been detected between these two output terminals.	<ol style="list-style-type: none"> 1. Check the motor and drive output terminal wiring for a shorted condition. 2. Replace drive if fault cannot be cleared.
F42	Phase UW Short			
F43	Phase VW Short			
F48	Params Defaulted		The drive was commanded to write default values to EEPROM.	<ol style="list-style-type: none"> 1. Clear the fault or cycle power to the drive. 2. Program the drive parameters as needed.
F63	SW OverCurrent	①	Programmed A098 [SW Current Trip] has been exceeded.	Check load requirements and A098 [SW Current Trip] setting.
F64	Drive Overload	②	Drive rating of 150% for 1 minute or 200% for 3 seconds has been exceeded.	Reduce load or extend Accel Time.
F70	Power Unit	②	Failure has been detected in the drive power section.	<ol style="list-style-type: none"> 1. Cycle power. 2. Replace drive if fault cannot be cleared.
F71	Net Loss		The communication network has faulted.	<ol style="list-style-type: none"> 1. Cycle power. 2. Check communications cabling. 3. Check network adapter setting. 4. Check external network status.
F80	SVC Autotune		The autotune function was either canceled by the user or failed.	Restart procedure.
F81	Comm Loss	②	RS-485 (DSI) port stopped communicating.	<ol style="list-style-type: none"> 1. If adapter was not intentionally disconnected, check wiring to the port. Replace wiring, port expander, adapters or complete drive as required. 2. Check connection. 3. An adapter was intentionally disconnected. 4. Turn off using A105 [Comm Loss Action].
F100	Parameter Checksum	②	The checksum read from the board does not match the checksum calculated.	Set P041 [Reset To Defaults] to option 1 "Reset Defaults".

Table 10 – Fault Types, Descriptions, and Actions (Continued)

No.	Fault	Type ⁽¹⁾	Description	Action
F122	I/O Board Fail	②	Failure has been detected in the drive control and I/O section.	<ol style="list-style-type: none"> 1. Cycle power. 2. Replace drive if fault cannot be cleared.

⁽¹⁾ See [page 91](#) for a description of fault types.

Common Symptoms and Corrective Actions

Motor does not Start.

Cause	Indication	Corrective Action
No output voltage to the motor	None	<p>Check the power circuit.</p> <ul style="list-style-type: none"> • Check the supply voltage. • Check all fuses and disconnects. <p>Check the motor.</p> <ul style="list-style-type: none"> • Verify that the motor is connected properly. <p>Check the control input signals.</p> <ul style="list-style-type: none"> • Verify that a Start signal is present. If 2-wire control is used, verify that either the Run Forward or Run Reverse signal is active, but not both. • Verify that I/O Terminal 01 is active. • Verify that P036 [Start Source] matches your configuration. • Verify that A095 [Reverse Disable] is not prohibiting movement.
Improper boost setting at initial start-up.	None	Set A084 [Boost Select] to option 2 “35.0, VT”.
Cause	Indication	Corrective Action
Drive is Faulted	Flashing red status light	<p>Clear fault.</p> <ul style="list-style-type: none"> • Press Stop • Cycle power • Set A100 [Fault Clear] to option 1 “Clear Faults”. • Cycle digital input if A051...A054 [Digital Inx Sel] is set to option 7 “Clear Fault”.

Drive does not Start from Start or Run Inputs wired to the terminal block.

Cause	Indication	Corrective Action
Drive is Faulted	Flashing red status light	Clear fault. <ul style="list-style-type: none"> • Press Stop • Cycle power • Set A100 [Fault Clear] to option 1 “Clear Faults”. • Cycle digital input if A051...A054 [Digital Inx Sel] is set to option 7 “Clear Fault”.
Incorrect programming. <ul style="list-style-type: none"> • P036 [Start Source] is set to option 0 “Keypad” or option 5 “RS-485 (DSI) Port”. • A051...A054 [Digital Inx Sel] is set to option 5 “Local” and the input is active. 	None	Check parameter settings.
Incorrect input wiring. See page 28 for wiring examples. <ul style="list-style-type: none"> • 2-wire control requires Run Forward, Run Reverse or Jog input. • 3-wire control requires Start and Stop inputs • Stop input is always required. 	None	Wire inputs correctly and/or install jumper.
Incorrect Sink/Source DIP switch setting.	None	Set switch to match wiring scheme.

Drive does not Start from Integral Keypad.

Cause	Indication	Corrective Action
Integral keypad is not enabled.	Green LED above Start key is not illuminated.	<ul style="list-style-type: none"> • Set parameter P036 [Start Source] to option 0 “Keypad”. • Set parameter A051...A054 [Digital Inx Sel] to option 5 “Local” and activate the input.
I/O Terminal 01 “Stop” input is not present.	None	Wire inputs correctly and/or install jumper.

Drive does not respond to changes in speed command.

Cause	Indication	Corrective Action
No value is coming from the source of the command.	The drive "Run" indicator is lit and output is 0 Hz.	<ul style="list-style-type: none"> • Check d012 [Control Source] for correct source. • If the source is an analog input, check wiring and use a meter to check for presence of signal. • Check d002 [Commanded Freq] to verify correct command.
Incorrect reference source is being selected via remote device or digital inputs.	None	<ul style="list-style-type: none"> • Check d012 [Control Source] for correct source. • Check d014 [Dig In Status] to see if inputs are selecting an alternate source. Verify settings for A051...A054 [Digital Inx Sel]. • Check P038 [Speed Reference] for the source of the speed reference. Reprogram as necessary. • Review the Speed Reference Control chart on page 33.

Motor and/or drive will not accelerate to commanded speed.

Cause	Indication	Corrective Action
Acceleration time is excessive.	None	Reprogram P039 [Accel Time 1] or A067 [Accel Time 2].
Excess load or short acceleration times force the drive into current limit, slowing or stopping acceleration.	None	<p>Compare d003 [Output Current] with A089 [Current Limit 1].</p> <p>Remove excess load or reprogram P039 [Accel Time 1] or A067 [Accel Time 2].</p> <p>Check for improper A084 [Boost Select] setting.</p>
Speed command source or value is not as expected.	None	<p>Verify d002 [Commanded Freq].</p> <p>Check d012 [Control Source] for the proper Speed Command.</p>
Programming is preventing the drive output from exceeding limiting values.	None	Check P035 [Maximum Freq] to insure that speed is not limited by programming.
Torque performance does not match motor characteristics.	None	<p>Set motor nameplate full load amps in parameter A126 [Motor NP FLA].</p> <p>Perform A127 [Autotune] "Static Tune" or "Rotate Tune" procedure.</p> <p>Set A125 [Torque Perf Mode] to option 0 "V/Hz".</p>

Motor operation is unstable.

Cause	Indication	Corrective Action
Motor data was incorrectly entered.	None	<ol style="list-style-type: none"> 1. Correctly enter motor nameplate data into P031, P032 and P033. 2. Enable A097 [Compensation]. 3. Use A084 [Boost Select] to reduce boost level.

Drive will not reverse motor direction.

Cause	Indication	Corrective Action
Digital input is not selected for reversing control.	None	Check [Digital Inx Sel] See page 58 . Choose correct input and program for reversing mode.
Digital input is incorrectly wired.	None	Check input wiring. See page 27 .
Motor wiring is improperly phased for reverse.	None	Switch two motor leads.
Reverse is disabled.	None	Check A095 [Reverse Disable].

Drive does not power up.

Cause	Indication	Corrective Action
No input power to drive.	None	Check the power circuit. <ul style="list-style-type: none"> • Check the supply voltage. • Check all fuses and disconnects.
Jumper between I/O Terminals P2 and P1 not installed and/or DC Bus Inductor not connected.	None	Install jumper or connect DC Bus Inductor.

Supplemental Drive Information

Drive, Fuse, and Circuit Breaker Ratings

The tables on the following pages provide recommended AC line input fuse and circuit breaker information. See Fusing and Circuit Breakers below for UL and IEC requirements. Sizes listed are the recommended sizes based on 40 °C (104 °F) and the U.S. N.E.C. Other country, state or local codes may require different ratings.

Fusing

The recommended fuse types are listed below. If available current ratings do not match those listed in the tables provided, choose the next higher fuse rating.

- IEC – BS88 (British Standard) Parts 1 & 2⁽¹⁾, EN60269-1, Parts 1 & 2, type gG or equivalent should be used.
- UL – UL Class CC, T, or J must be used.⁽²⁾

Circuit Breakers

The “non-fuse” listings in the following tables include inverse time circuit breakers, instantaneous trip circuit breakers (motor circuit protectors) and 140M/140MT self-protected combination motor controllers. If one of these is chosen as the desired protection method, the following requirements apply:

- IEC – Both types of circuit breakers and 140M/140MT self-protected combination motor controllers are acceptable for IEC installations.
- UL – Only inverse time circuit breakers and the specified 140M/140MT self-protected combination motor controllers are acceptable for UL installations.

⁽¹⁾ Typical designations include, but may not be limited to the following; Parts 1 & 2: AC, AD, BC, BD, CD, DD, ED, EFS, EF, FF, FG, GF, GG, GH.

⁽²⁾ Typical designations include; Type CC - KTK-R, FNQ-R
Type J - JKS, LPJ
Type T - JJS, JJN

Appendix A Supplemental Drive Information

Specifications

Drive Ratings

Catalog Number ⁽¹⁾	Output Ratings		Input Ratings			Branch Circuit Protection				
	kW (HP)	Amps	Voltage Range	kVA	Amps	Fuses	140M/140MT Motor Protectors ⁽³⁾⁽⁴⁾	Contactors	Min. Enclosure Volume ⁽⁵⁾ (in. ³)	
100...120V AC (±10%) – 1-phase Input, 0...230V 3-phase Output										
22B-V2P3x104	0.4 (0.5)	2.3	90...132	1.15	9.0	15	140M-C2E-C16 140MT-C3E-C16	100-C12	1655	
22B-V5P0x104	0.75 (1.0)	5.0	90...132	2.45	20.3	35	140M-D8E-C20 140MT-D9E-C20	100-C23	1655	
22B-V6P0x104	1.1 (1.5)	6.0	90...132	3.0	24.0	40	140M-F8E-C32	100-C37	1655	
200...240V AC (±10%) – 1-phase⁽⁴⁾ Input, 0...230V 3-phase Output										
22B-A2P3x104	0.4 (0.5)	2.3	180...264	1.15	6.0	10	140M-C2E-B63 140MT-C3E-B63	100-C09	1655	
22B-A5P0x104	0.75 (1.0)	5.0	180...264	2.45	12.0	20	140M-C2E-C16 140MT-C3E-C16	100-C12	1655	
22B-A8P0x104	1.5 (2.0)	8.0	180...264	4.0	18.0	30	140M-D8E-C20 140MT-D9E-C20	100-C23	1655	
22B-A012x104	2.2 (3.0)	12.0	180-264	5.5	25.0	40	140M-F8E-C32	100-C37	2069	
200...240V AC (±10%) – 3-phase Input, 0...230V 3-phase Output										
22B-B2P3x104	0.4 (0.5)	2.3	180...264	1.15	2.5	6	140M-C2E-B40 140MT-C3E-B40	100-C07	1655	
22B-B5P0x104	0.75 (1.0)	5.0	180...264	2.45	5.7	10	140M-C2E-B63 140MT-C3E-C10	100-C09	1655	
22B-B8P0x104	1.5 (2.0)	8.0	180...264	4.0	9.5	15	140M-C2E-C16 140MT-C3E-C16	100-C12	1655	
22B-B012x104	2.2 (3.0)	12.0	180...264	5.5	15.5	25	140M-C2E-C16 140MT-C3E-C16	100-C23	1655	
22B-B017x104	3.7 (5.0)	17.5	180...264	8.6	21.0	30	140M-F8E-C25	100-C23	1655	
22B-B024x104	5.5 (7.5)	24.0	180...264	11.8	26.1	40	140M-F8E-C32	100-C37	2069	
22B-B033x104	7.5 (10.0)	33.0	180...264	16.3	34.6	60	140M-F8E-C45	100-C60	2069	
380...480V AC (±10%) – 3-phase Input, 0...460V 3-phase Output										
22B-D1P4x104	0.4 (0.5)	1.4	342...528	1.4	1.8	3	140M-C2E-B25 140MT-C3E-B25	100-C07	1655	
22B-D2P3x104	0.75 (1.0)	2.3	342...528	2.3	3.2	6	140M-C2E-B40 140MT-C3E-B40	100-C07	1655	
22B-D4P0x104	1.5 (2.0)	4.0	342...528	4.0	5.7	10	140M-C2E-B63 140MT-C3E-B63	100-C09	1655	
22B-D6P0x104	2.2 (3.0)	6.0	342...528	5.9	7.5	15	140M-C2E-C10 140MT-C3E-C10	100-C09	1655	
22B-D010x104	4.0 (5.0)	10.5	342...528	10.3	13.0	20	140M-C2E-C16 140MT-C3E-C16	100-C23	1655	
22B-D012x104	5.5 (7.5)	12.0	342...528	11.8	14.2	25	140M-D8E-C20 140MT-D9E-C20	100-C23	2069	
22B-D017x104	7.5 (10.0)	17.0	342...528	16.8	18.4	30	140M-D8E-C20 140MT-D9E-C20	100-C23	2069	
22B-D024x104	11.0 (15.0)	24.0	342...528	23.4	26.0	50	140M-F8E-C32	100-C43	2069	
460...600V AC (±10%) – 3-phase Input, 0...575V 3-phase Output										
22B-E1P7x104	0.75 (1.0)	1.7	414...660	2.1	2.3	6	140M-C2E-B25	100-C09	1655	
22B-E3P0x104	1.5 (2.0)	3.0	414...660	3.65	3.8	6	140M-C2E-B40	100-C09	1655	
22B-E4P2x104	2.2 (3.0)	4.2	414...660	5.2	5.3	10	140M-D8E-B63	100-C09	1655	
22B-E6P6x104	4.0 (5.0)	6.6	414...660	8.1	8.3	15	140M-D8E-C10	100-C09	1655	

Drive Ratings (Continued)

Catalog Number ⁽¹⁾	Output Ratings		Input Ratings			Branch Circuit Protection			
	kW (HP)	Amps	Voltage Range	kVA	Amps	Fuses	140M/140MT Motor Protectors ⁽⁹⁾⁽⁴⁾	Contactors	Min. Enclosure Volume ⁽⁵⁾ (in. ³)
22B-E9P9x104	5.5 (7.5)	9.9	414...660	12.1	11.2	20	140M-D8E-C16	100-C16	2069
22B-E012x104	7.5 (10.0)	12.2	414...660	14.9	13.7	25	140M-D8E-C16	100-C23	2069
22B-E019x104	11.0 (15.0)	19.0	414...660	23.1	24.1	40	140M-F8E-C25	100-C30	2069

- (1) In the Catalog Numbers listed "x" represents enclosure type. Specifications are valid for all enclosure types. IP66, NEMA/UL Type 4X drive ratings are only available as Frame B drives. See [Table 2](#).
- (2) 200...240V AC - 1-phase drives are also available with an integral EMC filter. Catalog suffix changes from N104 to N114. Filter option is not available for IP66, NEMA/UL Type 4X rated drives.
- (3) The AIC ratings of the Bulletin 140M/140MT devices can vary. See See Motor Protection Circuit Breaker and Motor Circuit Protector Specifications Technical Data, publication [140-TD005](#) or [140M-TD002](#).
- (4) Manual Self-Protected (Type E) Combination Motor Controller, UL listed for 208 Wye or Delta, 240 Wye or Delta, 480Y/277 or 600Y/347. Not UL listed for use on 480V or 600V Delta/Delta, corner ground, or high-resistance ground systems.
- (5) When using a Manual Self-Protected (Type E) Combination Motor Controller, the drive must be installed in a ventilated or non-ventilated enclosure with the minimum volume specified in this column. Application specific thermal considerations may require a larger enclosure.

Approvals

			Radio communications Act, compliant with: EN 61800-3
	EMC Dir active: 2014/30/EU: EN 61800-3 NSF certifi ed to LV Directive: 2014/35/EU: EN 61800-5-1 NSF/ANSI 169		KCC-REM-RAA-2B
	EMC Regulations: 2016 No. 1091: EN 61800-3 LV Regulations: 2016 No. 1101: EN 61800-5-1		

Input/Output Ratings

Output Frequency: 0...400 Hz (Programmable)
Efficiency: 97.5% (Typical)

Digital Control Inputs (Input Current = 6mA)	Analog Control Inputs
SRC (Source) Mode: 18...24V = ON 0...6V = OFF	SNK (Sink) Mode: 0...6V = ON 18...24V = OFF
	4...20 mA Analog: 250 Ω input impedance 0...10V DC Analog: 100 kΩ input impedance External Pot: 1...10 kΩ, 2 Watt minimum

Control Output

Programmable Output (form C relay)	Opto Outputs	Analog Outputs (10 bit)
Resistive Rating: 3.0 A at 30V DC, 3.0 A at 125V AC, 3.0 A at 240V AC	30V DC, 50 mA	0...10V, 1k Ω min
Inductive Rating: 0.5 A at 30V DC, 0.5 A at 125V AC, 0.5 A at 240V AC	Non-inductive	4...20 mA, 525 Ω max

Fuses and Circuit Breakers

Recommended Fuse Type:	UL Class J, CC, T or Type BS88; 600V (550V) or equivalent
Recommended Circuit Breakers:	HMCP circuit breakers or equivalent

Protective Features

Motor Protection:	I ² t overload protection - 150% for 60 Secs, 200% for 3 Secs (Provides Class 10 protection)
Overcurrent:	200% hardware limit, 300% instantaneous fault

Over Voltage: 100-120V AC Input – Trip occurs at 405V DC bus voltage (equivalent to 150V AC incoming line)
 200...240V AC Input – Trip occurs at 405V DC bus voltage (equivalent to 150V AC incoming line)
 380...480V AC Input – Trip occurs at 810V DC bus voltage (equivalent to 575V AC incoming line)
 460...600V AC Input – Trip occurs at 1005V DC bus voltage (equivalent to 711V AC incoming line)

Under Voltage: 100-120V AC Input – Trip occurs at 210V DC bus voltage (equivalent to 75V AC incoming line)
 200...240V AC Input – Trip occurs at 210V DC bus voltage (equivalent to 150V AC incoming line)
 380...480V AC Input – Trip occurs at 390V DC bus voltage (equivalent to 275V AC incoming line)
 460...600V AC Input – If P042 = 3 "High Voltage" trip occurs at 487V DC bus voltage (344V AC incoming line);
 If P042 = 2 "Low Voltage" trip occurs at 390V DC bus voltage (275V AC incoming line)

Control Ride Through: Minimum ride through is 0.5 Secs - typical value 2 Secs

Faultless Power Ride Through: 100 milliseconds

Dynamic Braking

Internal brake IGBT included with all ratings except when no brake is specified.
See [Appendix B](#) for DB resistor ordering information.

Appendix A Supplemental Drive Information

Category	Specification	
Environment	Altitude:	1000 m (3300 ft) max. without derating
	Maximum Surrounding Air Temperature without derating:	
	IP20, NEMA/UL Type Open:	-10...+50° C (14...122° F)
	IP30, NEMA/UL Type 1	-10...+40° C (14...104° F)
	Flange Mount:	Heatsink: -10...+40° C (14...104° F) Drive: -10...+50° C (14...122° F)
	IP66, NEMA/UL Type 4X	-10...+40° C (14...104° F)
	Cooling Method	
	Convection:	0.4 kW (0.5 HP) drives
	Fan:	All other drive ratings and 0.4 kW (0.5 HP) 1-phase drives with Integral "S Type" EMC Filter
	Storage Temperature:	-40...+85 °C (-40...+185 °F)
Control	Atmosphere:	Important: Drive must not be installed in an area where the ambient atmosphere contains volatile or corrosive gas, vapors or dust. If the drive is not going to be installed for a period of time, it must be stored in an area where it will not be exposed to a corrosive atmosphere.
	Relative Humidity:	0...95% non-condensing
	Shock (operating):	15 g peak for 11 ms duration (±1.0 ms)
	Vibration (operating):	1 g peak, 5...2000 Hz
	Carrier Frequency	2...16 kHz. Drive rating based on 4 kHz
	Frequency Accuracy	
	Digital Input:	Within ±0.05% of set output frequency.
	Analog Input:	Within 0.5% of maximum output frequency, 10-bit resolution ±2% of full scale, 10-bit resolution
	Analog Output:	
	Speed Regulation - Open Loop with Slip Compensation:	±1% of base speed across a 60:1 speed range.
Electrical	Stop Modes:	Multiple programmable stop modes including - Ramp, Coast, DC-Brake, Ramp-to-Hold and S Curve.
	Accel/Decel:	Two independently programmable accel and decel times. Each time may be programmed from 0...600 seconds in 0.1 second increments.
	Intermittent Overload:	150% overload capability for up to 1 minute 200% overload capability for up to 3 seconds
	Electronic Motor Overload Protection:	Provides class 10 motor overload protection according to NEC article 430 and motor over-temperature protection according to NEC article 430.126 (A) (2). UL 508C File 29572.
	Voltage Tolerance:	100...120V ±10% 200...240V ±10% 380...480V ±10% 460...600V ±10%
	Frequency Tolerance:	48...63 Hz
	Input Phases:	Three-phase input provides full rating. Single-phase operation provides 35% rated current.
Displacement Power Factor:	0.98 across entire speed range	
Maximum Short Circuit Rating:	100,000 Amps Symmetrical	
Actual Short Circuit Rating:	Determined by AIC Rating of installed fuse/circuit breaker	
Transistor Type:	Insulated Gate Bipolar Transistor (IGBT)	

PowerFlex 40 Estimated Watts Loss (Rated Load, Speed & PWM)

Voltage	kW (HP)	External Watts	Internal Watts	Total Watts Loss
100...120V	0.4 (0.5)	22	18	40
	0.75 (1.0)	40	20	60
	1.1 (1.5)	58	22	80
200...240V	0.4 (0.5)	22	18	40
	0.75 (1.0)	40	20	60
	1.1 (2.0)	63	22	85
	2.2 (3.0)	100	25	125
	3.7 (5.0)	150	30	180
	5.5 (7.5)	200	35	235
	7.5 (10)	265	40	305
380...480V	0.4 (0.5)	17	18	35
	0.75 (1.0)	30	20	50
	1.1 (2.0)	48	22	70
	2.2 (3.0)	75	25	100
	3.7 (5.0)	135	25	160
	5.5 (7.5)	140	35	175
	7.5 (10)	175	35	210
	11 (15)	260	40	300
460...600V	0.75 (1.0)	30	20	50
	1.5 (2.0)	48	22	70
	2.2 (3.0)	75	25	100
	4.0 (5.0)	135	25	160
	5.5 (7.5)	140	35	175
	7.5 (10)	175	35	210
	11 (15)	260	40	300

Notes:

Accessories and Dimensions

Product Selection

Table 1 – Catalog Number Description

22B	-	A	1P5	N	1	1	4
Drive		Voltage Rating	Rating	Enclosure	HIM	Emission Class	Type

Table 2 – PowerFlex 40 Drives

Drive Ratings				IP20, NEMA/UL Type Open		IP20 Flange Mount ⁽¹⁾	IP66, NEMA/UL Type 4X
Input Voltage	kW	HP	Output Current	Catalog Number	Frame Size	Catalog Number	Catalog Number
120V 50/60 Hz 1-phase No Filter	0.4	0.5	2.3A	22B-V2P3N104	B	22B-V2P3F104	22B-V2P3C104
	0.75	1.0	5.0A	22B-V5P0N104	B	22B-V5P0F104	22B-V5P0C104
	1.1	1.5	6.0A	22B-V6P0N104	B	22B-V6P0F104	22B-V6P0C104
240V 50/60 Hz 1-phase With Integral "S Type" EMC Filter	0.4	0.5	2.3A	22B-A2P3N114	B	-	-
	0.75	1.0	5.0A	22B-A5P0N114	B	-	-
	1.5	2.0	8.0A	22B-A8P0N114	B	-	-
	2.2	3.0	12.0A	22B-A012N114	C	-	-
240V 50/60 Hz 1-phase No Filter	0.4	0.5	2.3A	22B-A2P3N104	B	22B-A2P3F104	22B-A2P3C104
	0.75	1.0	5.0A	22B-A5P0N104	B	22B-A5P0F104	22B-A5P0C104
	1.5	2.0	8.0A	22B-A8P0N104	B	22B-A8P0F104	22B-A8P0C104
	2.2	3.0	12.0A	22B-A012N104	C	22B-A012F104	-
240V 50/60 Hz 3-phase No Filter	0.4	0.5	2.3A	22B-B2P3N104	B	22B-B2P3F104	22B-B2P3C104
	0.75	1.0	5.0A	22B-B5P0N104	B	22B-B5P0F104	22B-B5P0C104
	1.5	2.0	8.0A	22B-B8P0N104	B	22B-B8P0F104	22B-B8P0C104
	2.2	3.0	12.0A	22B-B012N104	B	22B-B012F104	22B-B012C104
	3.7	5.0	17.5A	22B-B017N104	B	22B-B017F104	22B-B017C104
	5.5	7.5	24.0A	22B-B024N104	C	22B-B024F104	-
	7.5	10.0	33.0A	22B-B033N104	C	22B-B033F104	-
480V 50/60 Hz 3-phase No Filter	0.4	0.5	1.4A	22B-D1P4N104	B	22B-D1P4F104	22B-D1P4C104
	0.75	1.0	2.3A	22B-D2P3N104	B	22B-D2P3F104	22B-D2P3C104
	1.5	2.0	4.0A	22B-D4P0N104	B	22B-D4P0F104	22B-D4P0C104
	2.2	3.0	6.0A	22B-D6P0N104	B	22B-D6P0F104	22B-D6P0C104
	4.0	5.0	10.5A	22B-D010N104	B	22B-D010F104	22B-D010C104
	5.5	7.5	12.0A	22B-D012N104	C	22B-D012F104	-
	7.5	10.0	17.0A	22B-D017N104	C	22B-D017F104	-
	11.0	15.0	24.0A	22B-D024N104	C	22B-D024F104 ⁽²⁾	-

Appendix B Accessories and Dimensions

Table 2 – PowerFlex 40 Drives (Continued)

Drive Ratings				IP20, NEMA/UL Type Open		IP20 Flange Mount ⁽¹⁾	IP66, NEMA/UL Type 4X
Input Voltage	kW	HP	Output Current	Catalog Number	Frame Size	Catalog Number	Catalog Number
600V 50/60 Hz 3-phase No Filter	0.75	1.0	1.7A	22B-E1P7N104	B	22B-E1P7F104	22B-E1P7C104
	1.5	2.0	3.0A	22B-E3PON104	B	22B-E3POF104	22B-E3POC104
	2.2	3.0	4.2A	22B-E4P2N104	B	22B-E4P2F104	22B-E4P2C104
	4.0	5.0	6.6A	22B-E6P6N104	B	22B-E6P6F104	22B-E6P6C104
	5.5	7.5	9.9A	22B-E9P9N104	C	22B-E9P9F104	-
	7.5	10.0	12.0A	22B-E012N104	C	22B-E012F104	-
	11.0	15.0	19.0A	22B-E019N104	C	22B-E019F104	-

(1) Meets IP40/54/65 (NEMA 1/12/4/4X) when installed in an enclosure of like rating.

(2) Requires use of external DC Bus Inductor or AC Line Reactor. See [Table 5](#) for details.

Table 3 – Dynamic Brake Resistors

Drive Ratings				Catalog Number ⁽¹⁾⁽²⁾	Fuse Protection ⁽⁴⁾		
Input Voltage	kW	HP	Minimum Resistance Ω		BR-	DC+/BR+	DC-
120V 50/60 Hz 1-phase	0.4	0.5	48	AK-R2-091P500	PV-12A10F	1000GH-016	1000GH-016
	0.75	1.0	48	AK-R2-091P500	PV-12A10F	1000GH-016	1000GH-016
	1.1	1.5	48	AK-R2-091P500	PV-12A10F	1000GH-016	1000GH-016
240V 50/60 Hz 1-phase	0.4	0.5	48	AK-R2-091P500	PV-12A10F	1000GH-016	1000GH-016
	0.75	1.0	48	AK-R2-091P500	PV-12A10F	1000GH-016	1000GH-016
	1.5	2.0	48	AK-R2-091P500	PV-12A10F	1000GH-025	1000GH-025
	2.2	3.0	32	AK-R2-047P500	PV-20A10F	1000GH-032	1000GH-032
240V 50/60 Hz 3-phase	0.4	0.5	48	AK-R2-091P500	PV-12A10F	1000GH-016	1000GH-016
	0.75	1.0	48	AK-R2-091P500	PV-12A10F	1000GH-016	1000GH-016
	1.5	2.0	48	AK-R2-091P500	PV-12A10F	1000GH-025	1000GH-025
	2.2	3.0	32	AK-R2-047P500	PV-20A10F	1000GH-032	1000GH-032
	3.7	5.0	19	AK-R2-047P500	PV-30A10F	1000GH-040	1000GH-040
	5.5	7.5	13	AK-R2-030P1K2	PV-50A10F	1000GH-050	1000GH-050
	7.5	10.0	10	AK-R2-030P1K2	PV-63A10F	1000GH-063	1000GH-063
480V 50/60 Hz 3-phase	0.4	0.5	97	AK-R2-360P500	PV-12A10F	1000GH-016	1000GH-016
	0.75	1.0	97	AK-R2-360P500	PV-12A10F	1000GH-016	1000GH-016
	1.5	2.0	97	AK-R2-360P500	PV-12A10F	1000GH-016	1000GH-016
	2.2	3.0	97	AK-R2-120P1K2	PV-12A10F	1000GH-016	1000GH-016
	4.0	5.0	77	AK-R2-120P1K2	PV-15A10F	1000GH-032	1000GH-032
	5.5	7.5	55	AK-R2-120P1K2	PV-20A10F	1000GH-040	1000GH-040
	7.5	10.0	39	AK-R2-120P1K2	PV-30A10F	1000GH-040	1000GH-040
	11.0	15.0	24	AK-R2-120P1K2 ⁽³⁾	PV-50A10F	1000GH-050	1000GH-050
600V 50/60 Hz 3-phase	0.75	1.0	120	AK-R2-360P500	PV-10A10F	1000GH-016	1000GH-016
	1.5	2.0	120	AK-R2-360P500	PV-10A10F	1000GH-016	1000GH-016
	2.2	3.0	82	AK-R2-120P1K2	PV-15A10F	1000GH-016	1000GH-016
	4.0	5.0	82	AK-R2-120P1K2	PV-15A10F	1000GH-025	1000GH-025
	5.5	7.5	51	AK-R2-120P1K2	PV-20A10F	1000GH-025	1000GH-025
	7.5	10.0	51	AK-R2-120P1K2	PV-20A10F	1000GH-032	1000GH-032
	11.0	15.0	51	AK-R2-120P1K2 ⁽³⁾	PV-20A10F	1000GH-040	1000GH-040

(1) The resistors listed in this tables are rated for 5% duty cycle.

(2) Use of Rockwell resistors is always recommended. The resistors listed have been carefully selected for optimizing performance in a variety of applications. Alternative resistors may be used, however care must be taken when making a selection. See the PowerFlex Dynamic Braking Resistor Calculator Application Technique, publication [PFLEX-AT001](#).

(3) Requires two resistors wired in parallel.

(4) For IEC applications, DC Fuse is mandatory when these terminals are connected. Connect the fuse close to the terminal. Use the specified part number. PV-xxxxx fuse is from Bussman. 1000GH-xxx fuse is from Hinode.

Table 4 – Bulletin 1321-3R Series Line Reactors

Input Voltage	kW	HP	Fundamental Amps	Maximum Continuous Amps	Inductance mh	Watts Loss	Catalog Number ⁽¹⁾
240V 50/60 Hz 3-phase	0.4	0.5	4	6	12.0	21 W	1321-3R4-D
	0.75	1.0	8	12	3.0	29 W	1321-3R8-B
	1.5	2.0	8	12	1.5	19.5 W	1321-3R8-A
	2.2	3.0	12	18	1.25	26 W	1321-3R12-A
	3.7	5.0	18	27	0.8	36 W	1321-3R18-A
	5.5	7.5	25	37.5	0.5	48 W	1321-3R25-A
	7.5	10.0	35	52.5	0.4	49 W	1321-3R35-A
480V 50/60 Hz 3-phase	0.4	0.5	2	3	20.0	11.3 W	1321-3R2-B
	0.75	1.0	4	6	9.0	20 W	1321-3R4-C
	1.5	2.0	4	6	6.5	20 W	1321-3R4-B
	2.2	3.0	8	12	5.0	25.3 W	1321-3R8-C
	4.0	5.0	12	18	2.5	31 W	1321-3R12-B
	5.5	7.5	12	18	2.5	31 W	1321-3R12-B
	7.5	10.0	18	27	1.5	43 W	1321-3R18-B
	11.0	15.0	25	37.5	1.2	52 W	1321-3R25-B
600V 50/60 Hz 3-phase	0.75	1.0	2	3	20.0	11.3 W	1321-3R2-B
	1.5	2.0	4	6	6.5	20 W	1321-3R4-B
	2.2	3.0	4	6	6.5	20 W	1321-3R4-B
	4.0	5.0	8	12	5.0	25.3 W	1321-3R8-C
	5.5	7.5	12	18	2.5	31 W	1321-3R12-B
	7.5	10.0	12	18	2.5	31 W	1321-3R12-B
	11.0	15.0	18	27	1.5	43 W	1321-3R18-B

⁽¹⁾ Catalog numbers listed are for 3% impedance open style units. NEMA Type 1 and 5% impedance reactor types are also available. See 1321 Power Conditioning Products Technical Data, publication [1321-TD001](#).

Table 5 – DC Bus Inductors

Input Voltage	kW	HP	Amps	Inductance mh	MTE Catalog Number ⁽²⁾
240V 50/60 Hz 3-phase	5.5	7.5	32	0.85	32RB001
	7.5	10.0	40	0.5	40RB001
480V 50/60 Hz 3-phase	5.5	7.5	18	3.75	18RB004
	7.5	10.0	25	4.0	25RB005
	11.0	15.0	32	2.68	32RB003
600V 50/60 Hz 3-phase	5.5	7.5	12	6.0	12RB004
	7.5	10.0	18	6.0	18RB005
	11.0	15.0	25	4.0	25RB005

⁽²⁾ Use MTE RB Series or equivalent inductors.

Table 6 – EMC Line Filters

Drive Ratings			S Type Filter Catalog Number ⁽¹⁾	L Type Filter Catalog Number ⁽⁴⁾
Input Voltage	kW	HP		
120V 50/60 Hz 1-phase	0.4	0.5	–	22-RF018-BL
	0.75	1.0	–	22-RF018-BL
	1.1	1.5	–	22-RF018-BL

Table 6 – EMC Line Filters (Continued)

Drive Ratings			S Type Filter	L Type Filter
Input Voltage	kW	HP	Catalog Number ⁽¹⁾	Catalog Number ⁽⁴⁾
240V 50/60 Hz 1-phase	0.4	0.5	⁽²⁾	22-RF018-BL
	0.75	1.0	⁽²⁾	22-RF018-BL
	1.5	2.0	⁽²⁾	22-RF018-BL
	2.2	3.0	⁽²⁾	22-RF025-CL
240V 50/60 Hz 3-phase	0.4	0.5	22-RF021-BS ⁽³⁾	22-RF021-BL
	0.75	1.0	22-RF021-BS ⁽³⁾	22-RF021-BL
	1.5	2.0	22-RF021-BS ⁽³⁾	22-RF021-BL
	2.2	3.0	22-RF021-BS ⁽³⁾	22-RF021-BL
	3.7	5.0	22-RF021-BS ⁽³⁾	22-RF021-BL
	5.5	7.5	22-RF034-CS	22-RF034-CL
480V 50/60 Hz 3-phase	0.4	0.5	22-RF012-BS	22-RF012-BL
	0.75	1.0	22-RF012-BS	22-RF012-BL
	1.5	2.0	22-RF012-BS	22-RF012-BL
	2.2	3.0	22-RF012-BS	22-RF012-BL
	4.0	5.0	22-RF012-BS	22-RF012-BL
	5.5	7.5	22-RF018-CS	22-RF018-CL
	7.5	10.0	22-RF018-CS	22-RF018-CL
	11.0	15.0	22-RF026-CS	22-RF026-CL
600V 50/60 Hz 3-phase	0.75	1.0	–	22-RF8P0-BL
	1.5	2.0	–	22-RF8P0-BL
	2.2	3.0	–	22-RF8P0-BL
	4.0	5.0	–	22-RF8P0-BL
	5.5	7.5	–	22-RF015-CL
	7.5	10.0	–	22-RF015-CL
	11.0	15.0	–	22-RF024-CL

⁽¹⁾ This filter is suitable for use with a cable length of at least 10 meters (33 feet) for Class A and 1 meter (3.3 feet) for Class B environments.

⁽²⁾ These ratings can be ordered with internal “S Type” filters. See the Catalog Number explanation on [page 10](#) and [Table 2](#) for details.

⁽³⁾ Filter must be Series B or later.

⁽⁴⁾ This filter is suitable for use with a cable length of at least 100 meters (330 feet) for Class A and 5 meters for Class B environments.

Table 7 – Human Interface Module (HIM) Option Kits and Accessories

Item	Description	Catalog Number
LCD Display, Remote Panel Mount	Digital speed control CopyCat capable IP66 (NEMA Type 4X/12) indoor use only Includes 2.9 meter (9.51 feet) cable	22-HIM-C2S
LCD Display, Remote Handheld	Digital speed control Full numeric keypad CopyCat capable IP30 (NEMA Type 1) Includes 1.0 meter (3.3 Feet) cable Panel mount with optional Bezel Kit	22-HIM-A3
Bezel Kit	Panel mount for LCD Display, Remote Handheld unit, IP30 (NEMA Type 1)	22-HIM-B1
DSI HIM Cable (DSI HIM to RJ45 cable)	1.0 meter (3.3 feet) 2.9 meter (9.51 feet)	22-HIM-H10 22-HIM-H30

Table 8 – IP30/NEMA 1/UL Type 1 Kit

Item	Description	Drive Frame	Catalog Number
IP30/NEMA 1/UL Type 1 Kit	Field installed kit. Converts drive to IP30/NEMA 1/UL Type 1 enclosure. Includes conduit box with mounting screws and plastic top panel.	B	22-JBAB
		C	22-JBAC
IP30/NEMA 1/UL Type 1 Kit for Communication Option	Field installed kit. Converts drive to IP30/NEMA 1/UL Type 1 enclosure. Includes communication option conduit box with mounting screws and plastic top panel.	B	22-JBCB
		C	22-JBCC

Table 9 – Communication Option Kits and Accessories

Item	Description	Catalog Number
Communication Adapters	Embedded communication options for use with the PowerFlex 4-Class drives. Requires a Communication Adapter Cover (IP20, NEMA/UL Type 1 only. Ordered Separately) BACnet ControlNet® DeviceNet® EtherNet/IP™ LonWorks PROFIBUS DP	22-COMM-B 22-COMM-C 22-COMM-D 22-COMM-E 22-COMM-L 22-COMM-P
External DSI Communications Kit	External mounting kit for 22-COMM communication options	22-XCOMM-DC-BASE
External Comms Power Supply	Optional 100-240V AC Power Supply for External DSI Communications Kit.	20-XCOMM-AC-PS1
Compact I/O™ Module	Three channel	1769-SM2
Communication Adapter Cover	Cover that houses the DeviceNet Communication Adapter (IP20, NEMA/UL Type 1 only) B Frame Drive C Frame Drive	22B-CCB 22B-CCC
Universal Serial Bus (USB) Converter Module	Provides serial communication via DF1 protocol for use with Connected Components Workbench and DriveTools™ SP software. Includes: • 2 m (6.6 ft) USB cable (1) • 20-HIM-H10 cable (1) • 22-HIM-H10 cable (1)	1203-USB
DSI Cable	2.0 meter (6.6 feet) RJ45 to RJ45 cable, male to male connectors.	22-RJ45CBL-C20
Splitter Cable	RJ45 one to two port splitter cable	AK-U0-RJ45-SC1
Terminating Resistors	RJ45 120 Ohm resistors (2 pieces)	AK-U0-RJ45-TR1
Terminal Block	RJ45 Two-position terminal block (5 pieces)	AK-U0-RJ45-TB2P

Table 10 – Programming Software

Item	Description
Connected Components Workbench Software	Windows-based software packages for programming and configuring Allen-Bradley drives and other Rockwell Automation products. Compatibility: Microsoft Windows® Server 2012 ⁽¹⁾ , Windows Server 2012 R2, Windows Server 2016 ⁽¹⁾ , Windows Server 2019, Windows 10 IoT Enterprise 2016 LTSC 64-bit, Windows 10 IoT Enterprise 2019 LTSC, Windows 10, and Windows 11 ⁽²⁾ All supported operating systems require .NET Framework 3.5 SP1 to be installed. You can download Connected Components Workbench Standard Edition software for free at rok.auto/pcdc . To purchase Connected Components Workbench Developer Edition software, visit rok.auto/ccw .
DriveExecutive Software (Download as part of the DriveTools SP software package)	Windows-based software package that provides an intuitive means for monitoring or configuring Allen-Bradley drives and communications adapters online and offline. Compatibility: Microsoft Windows 7, Windows 10, and Windows Server 2019 You can download DriveTool SP software package at rok.auto/pcdc .

⁽¹⁾ Requires Connected Components Workbench software version 20.01.00 or earlier.

⁽²⁾ Requires Connected Components Workbench software version 20.01.00 or later.

Product Dimensions

Table 11 – PowerFlex 40 Frames – Ratings are in kW and (HP)

Frame	120V AC – 1-phase	240V AC – 1-phase	240V AC – 3-phase	480V AC – 3-phase	600V AC – 3-phase
B	0.4 (0.5) 0.75 (1.0) 1.1 (1.5)	0.4 (0.5) 0.75 (1.0) 1.5 (2.0)	0.4 (0.5) 2.2 (3.0) 0.75 (1.0) 3.7 (5.0) 1.5 (2.0)	0.4 (0.5) 2.2 (3.0) 0.75 (1.0) 4.0 (5.0) 1.5 (2.0)	0.75 (1.0) 2.2 (3.0) 1.5 (2.0) 4.0 (5.0)
C ⁽¹⁾		2.2 (3.0)	5.5 (7.5) 7.5 (10.0)	5.5 (7.5) 11.0 (15.0) 7.5 (10.0)	5.5 (7.5) 11.0 (15.0) 7.5 (10.0)

⁽¹⁾ IP66, NEMA/UL Type 4X rated drives are not available in Frame C drive ratings.

Figure 1 IP20, NEMA/UL Type Open

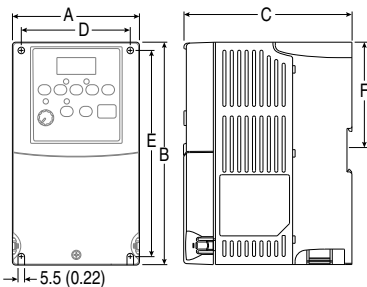

Dimensions are in millimeters and (inches).
Weights are in kilograms and (pounds).

Frame	A	B	C	D	E	F	Ship Weight
B	100 (3.94)	180 (7.09)	136 (5.35)	87 (3.43)	168 (6.61)	87.4 (3.44)	2.2 (4.9)
C	130 (5.1)	260 (10.2)	180 (7.1)	116 (4.57)	246 (9.7)	–	4.3 (9.5)

Figure 2 IP30, NEMA/UL Type 1 Option Kit without Communication Option

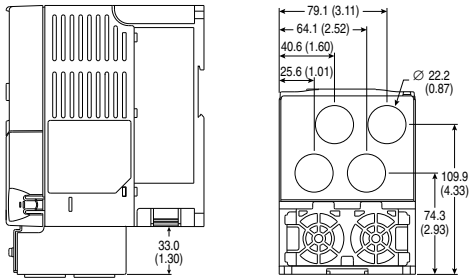

Frame B - 22-JBAB

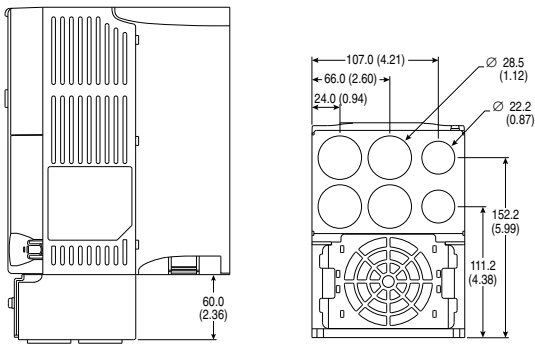

Frame C - 22-JBAC

Figure 3 IP30, NEMA/UL Type 1 Option Kit with Communication Option
 Dimensions are in millimeters and (inches)

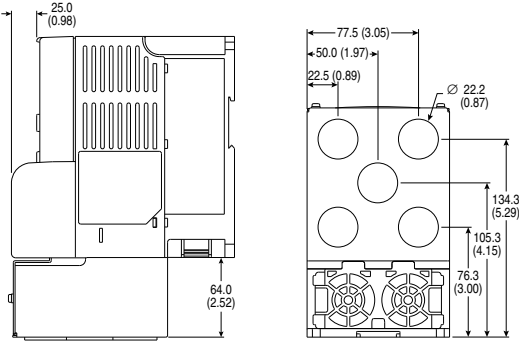

Frame B - 22-JBCB

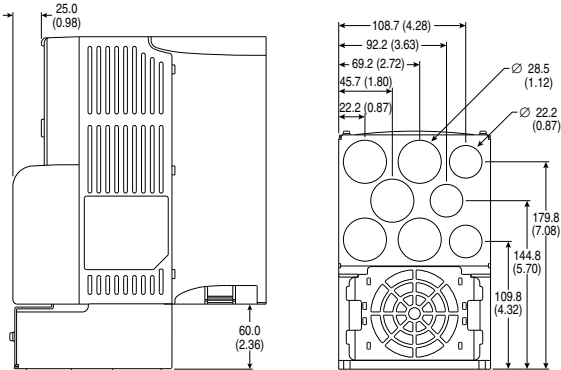

Frame C - 22-JBCC

Figure 4 PowerFlex 40 Flange Mount Drives
Dimensions are in millimeters and (inches)

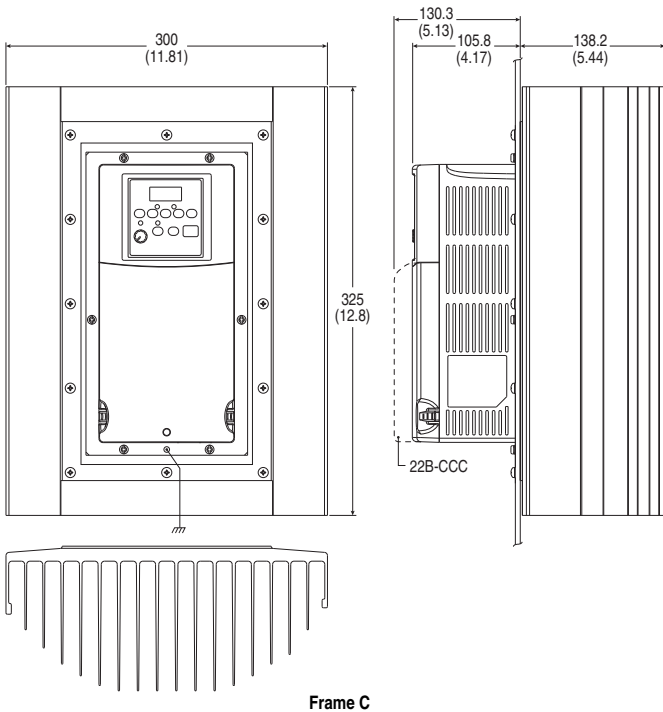
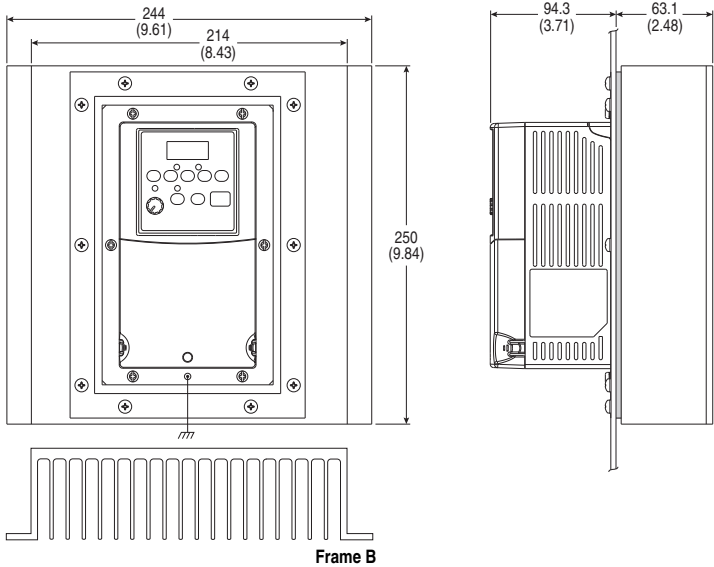
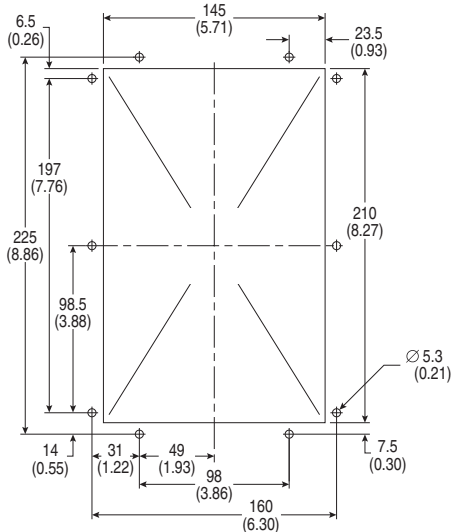
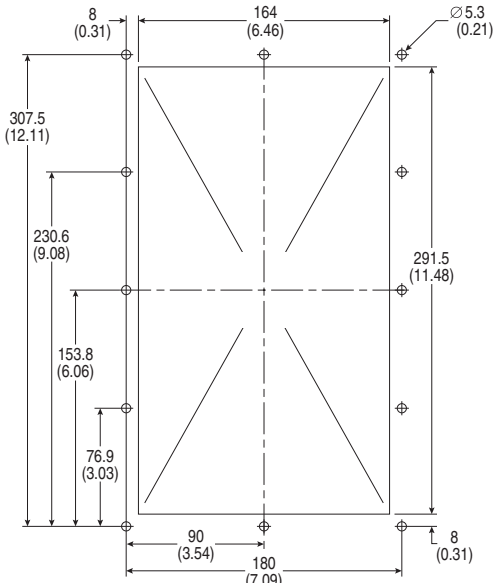

Figure 5 PowerFlex 40 Flange Mount Cutout Dimensions

Dimensions are in millimeters and (inches)



Frame B



Frame C

Figure 6 PowerFlex 40 Replacement Plate Drive Dimensions

Dimensions are in millimeters and (inches)

**Frame B****Frame C**

Figure 7 IP66, NEMA Type/UL Type 4X

Dimensions are in millimeters and (inches). Weights are in kilograms and (pounds).

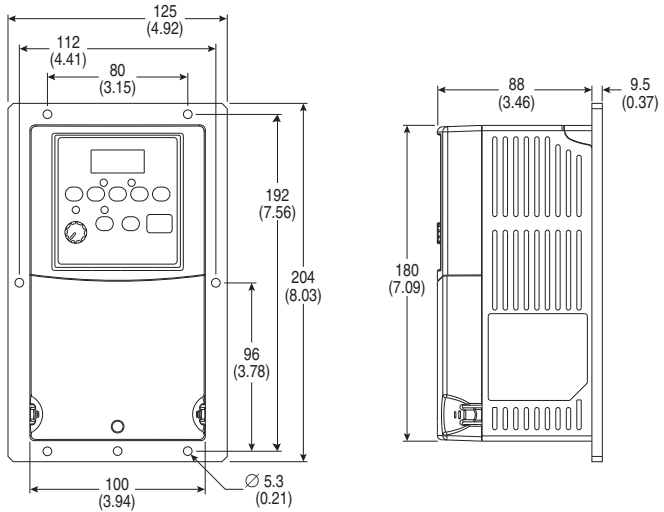
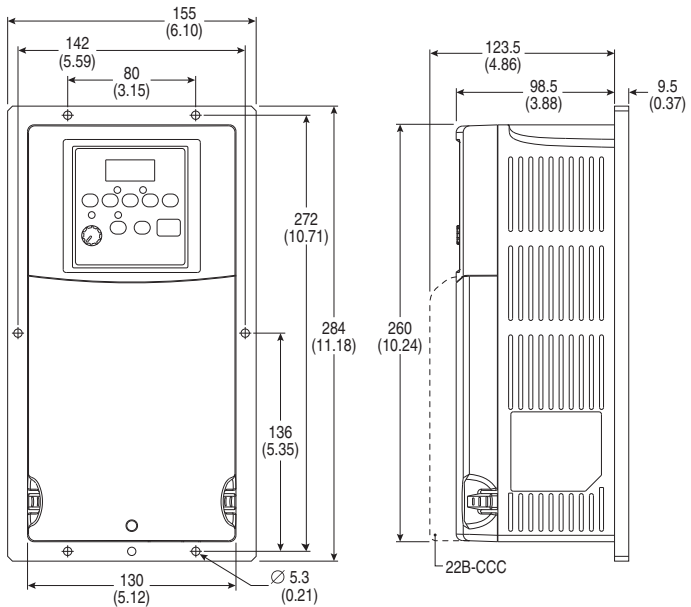
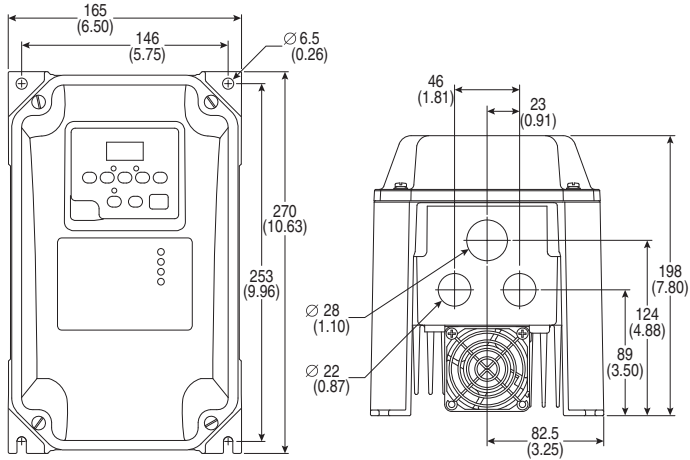

Weight
5.2 (11.5)

Figure 8 Dynamic Brake Modules

Dimensions are in millimeters and (inches). Weights are in kilograms and (pounds).

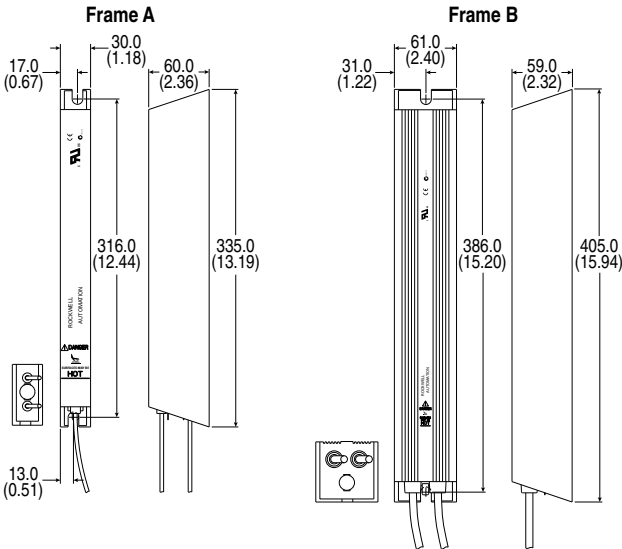

Frame	Catalog Number	Weight
A	AK-R2-091P500, AK-R2-047P500, AK-R2-360P500	1.1 (2.5)
B	AK-R2-030P1K2, AK-R2-120P1K2	2.7 (6)

Figure 9 Recommended External Brake Resistor Circuitry

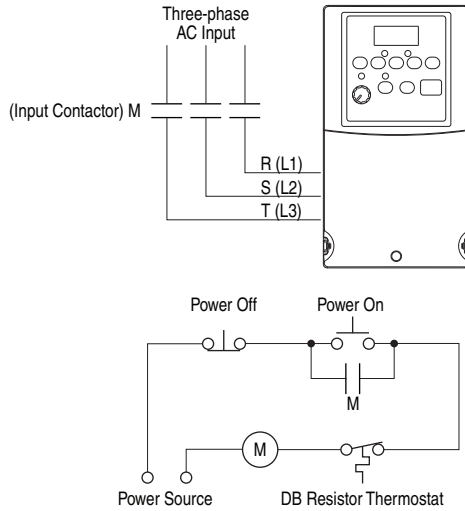
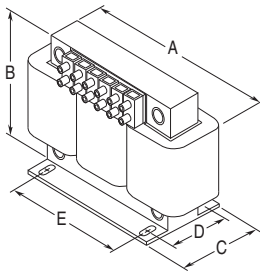

Figure 10 Bulletin 1321-3R Series Line Reactors

Dimensions are in millimeters and (inches). Weights are in kilograms and (pounds).



Catalog Number	A	B	C	D	E	Weight
1321-3R2-A	112 (4.40)	104 (4.10)	70 (2.75)	50 (1.98)	37 (1.44)	1.8 (4)
1321-3R2-B	112 (4.40)	104 (4.10)	70 (2.75)	50 (1.98)	37 (1.44)	1.8 (4)
1321-3R4-A	112 (4.40)	104 (4.10)	76 (3.00)	50 (1.98)	37 (1.44)	1.8 (4)
1321-3R4-B	112 (4.40)	104 (4.10)	76 (3.00)	50 (1.98)	37 (1.44)	1.8 (4)
1321-3R4-C	112 (4.40)	104 (4.10)	86 (3.38)	60 (2.35)	37 (1.44)	2.3 (5)
1321-3R4-D	112 (4.40)	104 (4.10)	92 (3.62)	66 (2.60)	37 (1.44)	2.7 (6)
1321-3R8-A	152 (6.00)	127 (5.00)	76 (3.00)	53 (2.10)	51 (2.00)	3.1 (7)
1321-3R8-B	152 (6.00)	127 (5.00)	76 (3.00)	53 (2.10)	51 (2.00)	3.6 (8)
1321-3R8-C	152 (6.00)	127 (5.00)	85 (3.35)	63 (2.48)	51 (2.00)	4.9 (11)
1321-3R12-A	152 (6.00)	127 (5.00)	76 (3.00)	53 (2.10)	51 (2.00)	4.1 (9)
1321-3R12-B	152 (6.00)	127 (5.00)	76 (3.00)	53 (2.10)	51 (2.00)	4.5 (10)
1321-3R18-A	152 (6.00)	133 (5.25)	79 (3.10)	54 (2.13)	51 (2.00)	4.1 (9)
1321-3R18-B	152 (6.00)	133 (5.25)	86 (3.40)	63 (2.48)	51 (2.00)	5.4 (12)
1321-3R25-A	183 (7.20)	146 (5.76)	85 (3.35)	60 (2.35)	76 (3.00)	4.9 (11)
1321-3R35-A	193 (7.60)	146 (5.76)	91 (3.60)	66 (2.60)	76 (3.00)	6.3 (14)

Figure 11 Frame B EMC Line Filters

Dimensions are in millimeters and (inches)

Catalog Numbers: 22-RF8P0-BL, 22-RF012-BS, 22-RF012-BL (series B); 22-RF018-BS;
22-RF021-BS, 22-RF021-BL

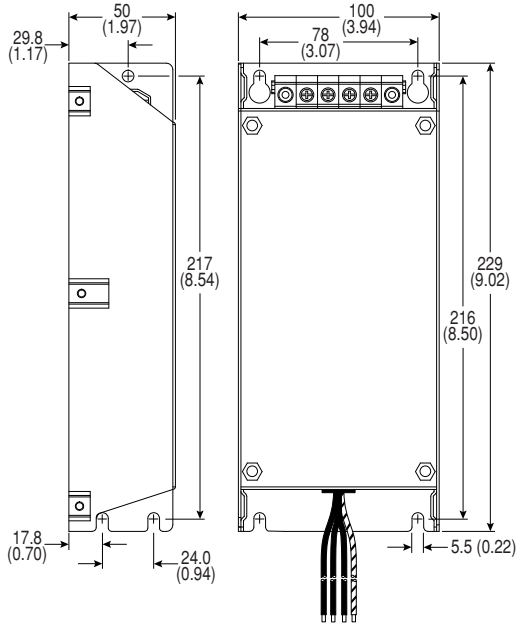

Figure 12 Frame C EMC Line Filters

Dimensions are in millimeters and (inches)

Catalog Numbers: 22-RF018-CS, 22-RF018-CL; 22-RF025-CL; 22-RF026-CS,
22-RF026-CL; 22-RF034-CS, 22-RF034-CL

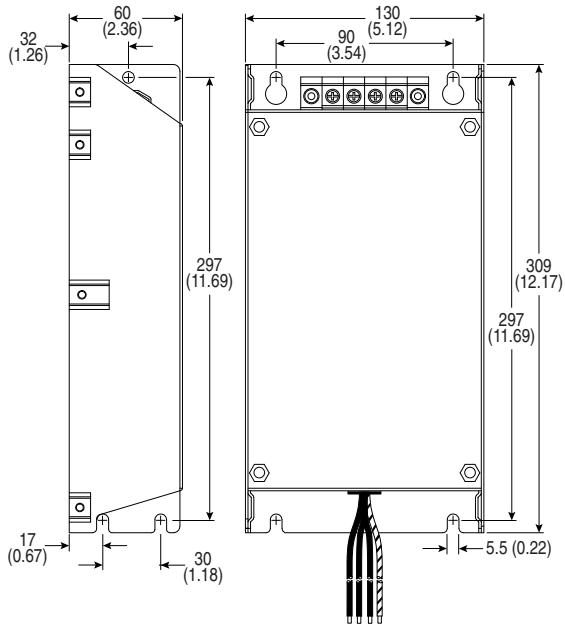

Figure 13 Remote (Panel Mount) Small HIM

Dimensions are in millimeters and (inches)

Catalog Number: 22-HIM-C2S

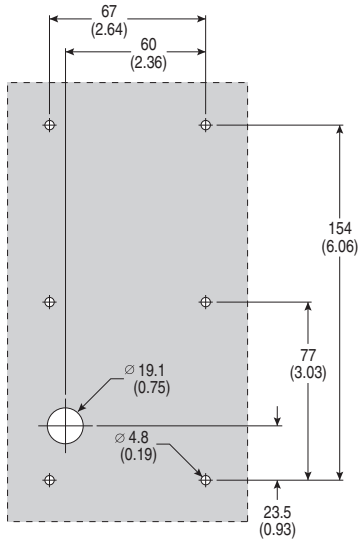
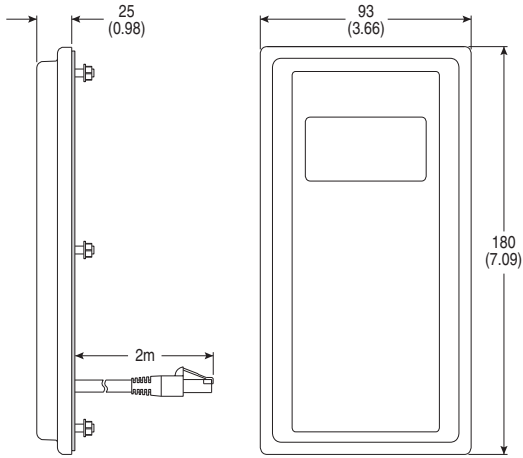
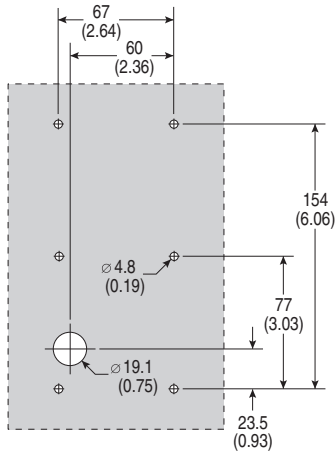
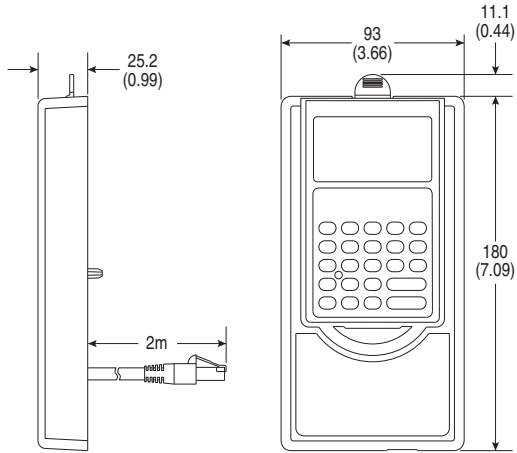

Figure 14 NEMA Type 1 Bezel
 Dimensions are in millimeters and (inches)
 Catalog Number: 22-HIM-B1



Notes:

RS-485 (DSI) Protocol

PowerFlex 40 drives support the RS-485 (DSI) protocol to allow efficient operation with Rockwell Automation peripherals. In addition, some Modbus functions are supported to allow simple networking. PowerFlex 40 drives can be multi-dropped on an RS-485 network using Modbus protocol in RTU mode.

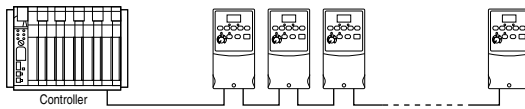

For information regarding DeviceNet or other communication protocols, see the appropriate user manual.

Network Wiring

Network wiring consists of a shielded 2-conductor cable that is daisy-chained from node to node.

Figure 15 Network Wiring Diagram

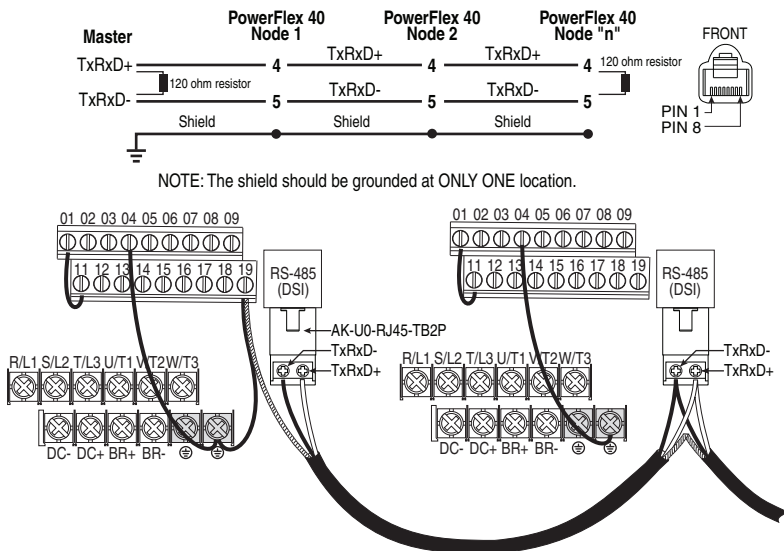

Only pins 4 and 5 on the RJ45 plug should be wired. The other pins on the PowerFlex 40 RJ45 socket must not be connected because they contain power, and so on for other Rockwell Automation peripheral devices.

Wiring terminations on the master controller will vary depending on the master controller used and “TxRx+” and “TxRx-” are shown for illustration purposes only. See the master controller’s user manual for network terminations. Note that there is no standard for the “+” and “-” wires, and consequently Modbus device manufacturers interpret them differently. If you have problems with initially establishing communications, try swapping the two network wires at the master controller.

Standard RS-485 wiring practices apply.

- Termination resistors need to be applied at each end of the network cable.
- RS-485 repeaters may need to be used for long cable runs, or if greater than 32 nodes are needed on the network.
- Network wiring should be separated from power wires by at least 0.3 meters (1 foot).
- Network wiring should only cross power wires at a right angle.

I/O Terminal 19 on the PowerFlex 40 drive is connected to the metal shield around the RJ45 connector. It is recommended to ground this terminal (there are two PE terminals on the drive). See [Table 8](#) for more information.

Network Common is internally tied to I/O Terminal 04 (Digital Common). Tying I/O Terminal 04 to PE ground may improve noise immunity in some applications.

Parameter Configuration

The following PowerFlex 40 parameters are used to configure the drive to operate on a network.

Parameter	Details	Reference
P036 [Start Source]	Set to 5 "RS-485 (DSI) Port" if Start is controlled from the network.	page 54
P038 [Speed Reference]	Set to 5 "RS-485 (DSI) Port" if the Speed Reference is controlled from the network.	page 56
A103 [Comm Data Rate]	Sets the data rate for the RS-485 (DSI) Port. All nodes on the network must be set to the same data rate.	page 75
A104 [Comm Node Addr]	Sets the node address for the drive on the network. Each device on the network requires a unique node address.	page 75
A105 [Comm Loss Action]	Selects the drive's response to communication problems.	page 76
A106 [Comm Loss Time]	Sets the time that the drive will remain in communication loss before the drive implements A105 [Comm Loss Action].	page 76
A107 [Comm Format]	Sets the transmission mode, data bits, parity and stop bits for the RS-485 (DSI) Port. All nodes on the network must be set to the same setting.	page 76

Supported Modbus Function Codes

The peripheral interface (DSI) used on PowerFlex 40 drives supports some of the Modbus function codes.

Modbus Function Code (Decimal)	Command
03	Read Holding Registers
06	Preset (Write) Single Register
16 (10 Hexadecimal)	Preset (Write) Multiple Registers

Important: Modbus devices can be 0-based (registers are numbered starting at 0) or 1-based (registers are numbered starting at 1). Depending on the Modbus Master used, the register addresses listed on the following pages may need to be offset by +1. For example, Logic Command may be register address 8192 for some master devices (for example, ProSoft 3150-MCM SLC™ Modbus scanner) and 8193 for others (for example, PanelView™).

Writing (06) Logic Command Data

The PowerFlex 40 drive can be controlled via the network by sending Function Code 06 writes to register address 8192 (Logic Command). P036 [Start Source] must be set to 5 “RS-485 (DSI) Port” in order to accept the commands.

In addition to being written, register address 8192 can be read using Function Code 03.

		Logic Command	
Address (Decimal)	Bits	Description	
8192	0	1 = Stop, 0 = Not Stop	
	1	1 = Start, 0 = Not Start	
	2	1 = Jog, 0 = No Jog	
	3	1 = Clear Faults, 0 = Not Clear Faults	
	5,4		00 = No Command
			01 = Forward Command
			10 = Reverse Command
			11 = No Command
	6	Not used in FRN 3.03 and earlier. In FRN 4.01 and later, activates Opto Output 1. Note: This bit controls the output when the value of parameter A058 is set to 20.	
	7	Not used in FRN 3.03 and earlier. In FRN 4.01 and later, activates Opto Output 2. Note: This bit controls the output when the value of parameter A061 is set to 20.	
	9,8		00 = No Command
			01 = Accel Rate 1 Enable
			10 = Accel Rate 2 Enable
			11 = Hold Accel Rate Selected
	11,10		00 = No Command
			01 = Decel Rate 1 Enable
			10 = Decel Rate 2 Enable
		11 = Hold Decel Rate Selected	
14,13,12		000 = No Command	
		001 = Freq. Source = P038 [Speed Reference]	
		010 = Freq. Source = A069 [Internal Freq]	
		011 = Freq. Source = Comms (Addr 8193)	
		100 = A070 [Preset Freq 0]	
		101 = A071 [Preset Freq 1]	
		110 = A072 [Preset Freq 2]	
	111 = A073 [Preset Freq 3]		
15	Not used in FRN 3.03 and earlier. In FRN 4.01 and later, activates C-form relay. Note: This bit controls the output when the value of parameter A055 is set to 20.		

Writing (06) Reference

The Speed Reference to a PowerFlex 40 drive can be controlled via the network by sending Function Code 06 writes to register address 8193 (Reference). P038 [Speed Reference] must be set to 5 “RS-485 (DSI) Port” in order to accept the Speed Reference.

In addition to being written, register address 8193 can be read using Function Code 03.

Reference	
Address (Decimal)	Description
8193	A decimal value entered as xxx.x where the decimal point is fixed. For example, a decimal “100” equals 10.0 Hz and “543” equals 54.3 Hz.

Reading (03) Logic Status Data

The PowerFlex 40 Logic Status data can be read via the network by sending Function Code 03 reads to register address 8448 (Logic Status).

Logic Status		
Address (Decimal)	Bit(s)	Description
8448	0	1 = Ready, 0 = Not Ready
	1	1 = Active (Running), 0 = Not Active
	2	1 = Cmd Forward, 0 = Cmd Reverse
	3	1 = Rotating Forward, 0 = Rotating Reverse
	4	1 = Accelerating, 0 = Not Accelerating
	5	1 = Decelerating, 0 = Not Decelerating
	6	1 = Alarm, 0 = No Alarm
	7	1 = Faulted, 0 = Not Faulted
	8	1 = At Reference, 0 = Not At Reference
	9	1 = Reference Controlled by Comm
	10	1 = Operation Cmd Controlled by Comm
	11	1 = Parameters have been locked
	12	Digital Input 1 Status
	13	Digital Input 2 Status
	14	Digital Input 3 Status ⁽¹⁾
15	Digital Input 4 Status ⁽¹⁾	

⁽¹⁾ This status is available only with firmware revision FRN 2.xx and higher.

Reading (03) Feedback

The Feedback (Output Frequency) from the PowerFlex 40 drive can be read via the network by sending Function Code 03 reads to register address 8451 (Feedback).

Feedback ⁽²⁾	
Address (Decimal)	Description
8451	A xxx.x decimal value where the decimal point is fixed. For example, a decimal “123” equals 12.3 Hz and “300” equals 30.0 Hz.

⁽²⁾ Returns the same data as Reading (03) Parameter d001 [Output Freq].

Reading (03) Drive Error Codes

The PowerFlex 40 Error Code data can be read via the network by sending Function Code 03 reads to register address 8449 (Drive Error Codes).

		Logic Status
Address (Decimal)	Value (Decimal)	Description
8449	0	No Fault
	2	Auxiliary Input
	3	Power Loss
	4	Undervoltage
	5	Overvoltage
	6	Motor Stalled
	7	Motor Overload
	8	Heatsink Overtemperature
	12	HW Overcurrent (300%)
	13	Ground Fault
	29	Analog Input Loss
	33	Auto Restart Tries
	38	Phase U to Ground Short
	39	Phase V to Ground Short
	40	Phase W to Ground Short
	41	Phase UV Short
	42	Phase UW Short
	43	Phase VW Short
	63	Software Overcurrent
	64	Drive Overload
70	Power Unit Fail	
80	AutoTune Fail	
81	Communication Loss	
100	Parameter Checksum Error	
122	I/O Board Fail	

Reading (03) and Writing (06) Drive Parameters

To access drive parameters, the Modbus register address equals the parameter number. For example, a decimal “1” is used to address Parameter [d001](#) [Output Freq] and decimal “39” is used to address Parameter [P039](#) [Accel Time 1].

Additional Information

Visit www.rockwellautomation.com/en-us/products/hardware/allen-bradley/vfd.html for additional information.

RJ45 DSI Splitter Cable

The PowerFlex 40 drive provides a RJ45 port to allow the connection of a single peripheral device. The RJ45 DSI splitter cable can be used to connect a second DSI peripheral device to the drive.

Connectivity Guidelines



ATTENTION: Risk of injury or equipment damage exists. The peripherals may not perform as intended if these Connectivity Guidelines are not followed. Precautions should be taken to follow these Connectivity Guidelines.

- Two peripherals maximum can be attached to a drive.
- If a single peripheral is used, it must be connected to the Master port (M) on the splitter and configured for “Auto” (default) or “Master.” Parameter 9 [Device Type] on the DSI / MDI keypads and Parameter 1 [Adapter Cfg] on the Serial Converter are used to select the type (Auto / Master / Slave).
- **Do not use the RJ45 splitter cable with a drive that has an internal network communication adapter installed.** Since only one additional peripheral can be added, the second peripheral can be connected directly to the RJ45 port on the drive. The internal Comm is always the Master, therefore the external peripheral must be configured as “Auto” (for temporary connections) or “Slave” (for permanent connections).
- If two peripherals will be powered up at the same time, one must be configured as the “Master” and connected to the Master port (M) and the other must be connected as the “Slave” and connected to the Slave port (S).

RJ45 Cable Accessories

RJ45 Splitter Cable – Catalog Number: AK-U0-RJ45-SC1

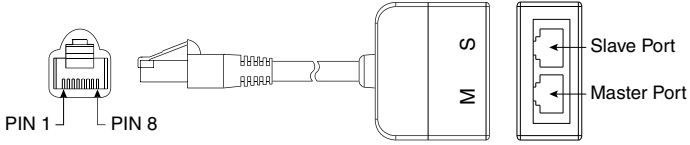

RJ45 Two-Position Terminal Block Adapter –

Catalog Number: AK-U0-RJ45-TB2P

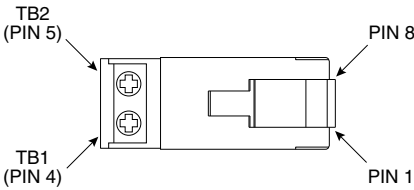

RJ45 Adapter with Integrated Termination Resistor –

Catalog Number: AK-U0-RJ45-TR1

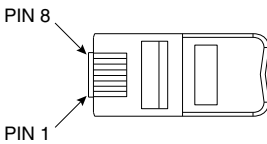

Connecting One Temporary Peripheral

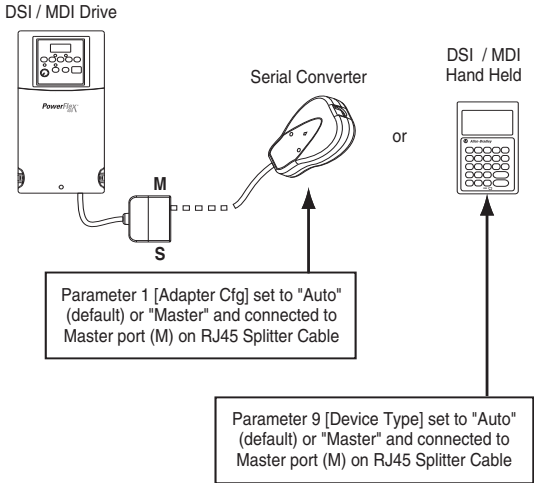

Connecting One Temporary Peripheral and One Permanent Peripheral

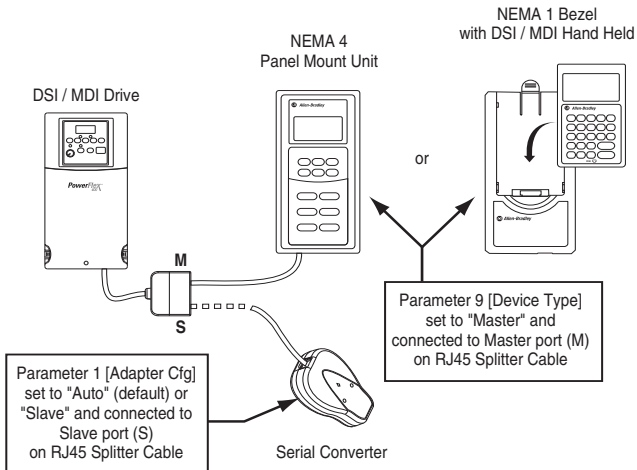

Connecting Two Permanent Peripherals

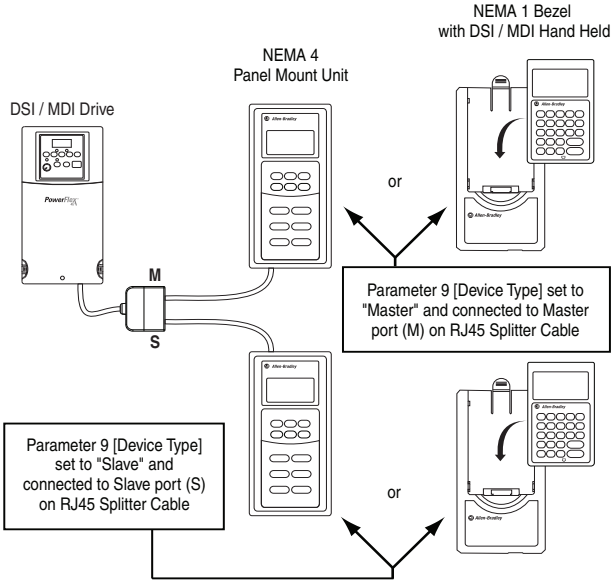

Connecting an RS-485 Network

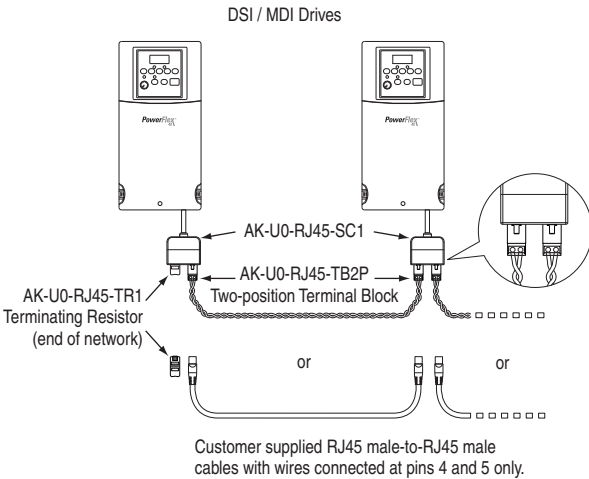

Both the Master (M) and Slave (S) ports on the RJ45 Splitter Cable operate as standard RS-485 ports in this configuration.

StepLogic, Basic Logic, Timer/Counter

Four PowerFlex 40 logic functions provide the capability to program simple logic functions without a separate controller.

- StepLogic™ Function

Steps through up to eight preset speeds based on programmed logic. Programmed logic can include conditions that need to be met from digital inputs programmed as “Logic In1” and “Logic In2” before stepping from one preset speed to the next. A timer is available for each of the eight steps and is used to program a time delay before stepping from one preset speed to the next. The status of a digital output can also be controlled based on the step being executed.

- Basic Logic Function

Up to two digital inputs can be programmed as “Logic In1” and/or “Logic In2”. A digital output can be programmed to change state based on the condition of one or both inputs based on basic logic functions such as AND, OR, NOR. The basic logic functions can be used with or without StepLogic.

- Timer Function

A digital input can be programmed for “Timer Start”. A digital output can be programmed as a “Timer Out” with an output level programmed to the desired time. When the timer reaches the time programmed into the output level the output will change state. The timer can be reset via a digital input programmed as “Reset Timer”.

- Counter Function

A digital input can be programmed for “Counter In”. A digital output can be programmed as “Counter Out” with an output level programmed to the desired number of counts. When the counter reaches the count programmed into the output level the output will change state. The counter can be reset via a digital input programmed as “Reset Counter”.

StepLogic Using Timed Steps

To activate this function, set parameter P038 [Speed Reference] to 6 “Step Logic”. Three parameters are used to configure the logic, speed reference and time for each step.

- Logic is defined using parameters A140...A147 [Stp Logic x].
- Preset Speeds are set with parameters A070...A077 [Preset Freq x].
- Time of operation for each step is set with parameters A150...A157 [Stp Logic Time x].

The direction of motor rotation can be forward or reverse.

Figure 16 Using Timed Steps

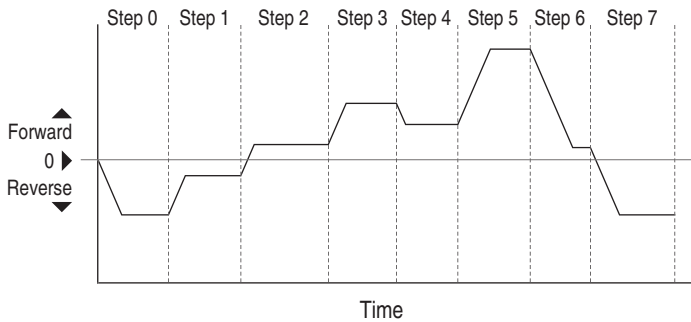

StepLogic Sequence

- Sequence begins with a valid start command.
- A normal sequence begins with Step 0 and transition to the next step when the corresponding StepLogic time has expired.
- Step 7 is followed by Step 0.
- Sequence repeats until a stop is issued or a fault condition occurs.

StepLogic Using Basic Logic Functions

Digital input and digital output parameters can be configured to use logic to transition to the next step. Logic In1 and Logic In2 are defined by programming parameters A051...A054 [Digital Inx Sel] to option 23 “Logic In1” or option 24 “Logic In2”.

Example

- Run at Step 0.
- Transition to Step 1 when Logic In1 is true.
Logic senses the edge of Logic In1 when it transitions from off to on. Logic In1 is not required to remain “on”.
- Transition to Step 2 when both Logic In1 and Logic In2 are true.
The drive senses the level of both Logic In1 and Logic In2 and transitions to Step 2 when both are on.
- Transition to Step 3 when Logic In2 returns to a false or off state.
Inputs are not required to remain in the “on” condition except under the logic conditions used for the transition from Step 2 to Step 3.

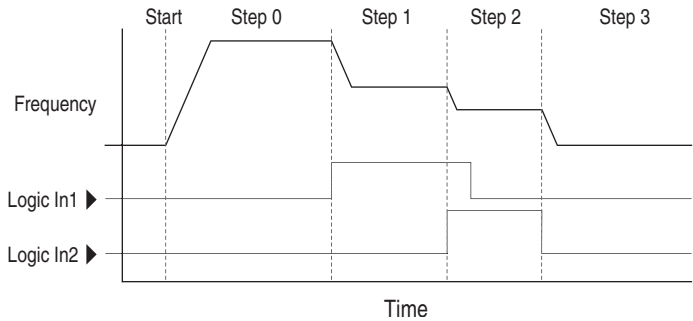

The step time value and the basic logic may be used together to satisfy machine conditions. For instance, the step may need to run for a minimum time period and then use the basic logic to trigger a transition to the next step.

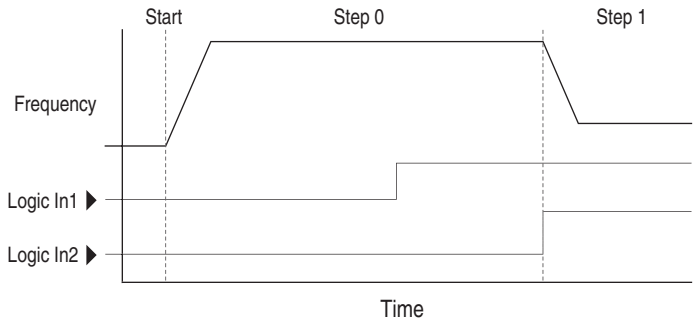

Timer Function

Digital inputs and outputs control the timer function and are configured with parameters A051...A054 [Digital Inx Sel] set to 18 “Timer Start” and 20 “Reset Timer”.

Digital outputs (relay and opto type) define a preset level and indicate when the level is reached. Level parameters A056 [Relay Out Level], A059 [Opto Out1 Level], and A062 [Opto Out2 Level] are used to set the desired time in seconds.

Parameters A055 [Relay Out Sel], A058 [Opto Out1 Sel] and A061 [Opto Out2 Sel] are set to option 16 “Timer Out” and causes the output to change state when the preset level is reached.

Example

- Drive starts up and accelerates to 30 Hz.
- After 30 Hz has been maintained for 20 seconds, a 4...20 mA analog input becomes the reference signal for speed control.
- The timer function is used to select a preset speed with a 20 second run time that overrides the speed reference while the digital input is active.
- Parameters are set to the following options:
 - P038 [Speed Reference] = 3 “4-20mA Input”
 - A051 [Digital In1 Sel] = 4 “Preset Freq”
 - A052 [Digital In2 Sel] = 18 “Timer Start”
 - A055 [Relay Out Sel] = 16 “Timer Out”
 - A056 [Relay Out Level] = 20.0 Secs
 - A071 [Preset Freq 1] = 30.0 Hz
- The control terminal block is wired such that a start command will also trigger the timer start.
- The relay output is wired to I/O Terminal 05 (Digital Input 1) so that it forces the input on when the timer starts.
- After the timer is complete, the output is turned off releasing the preset speed command. The drive defaults to following the analog input reference as programmed.

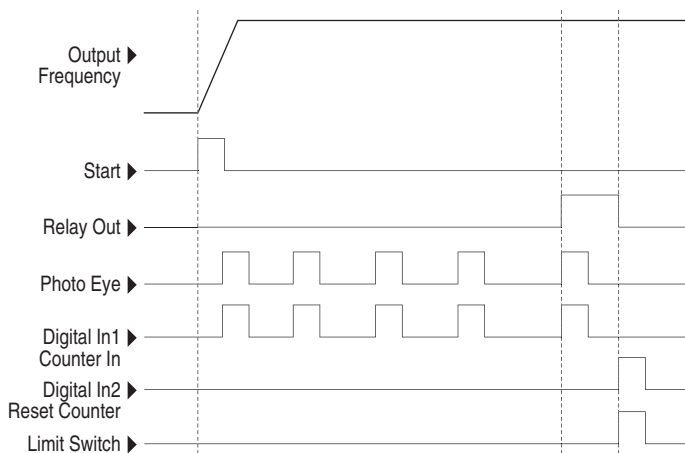

Note that a “Reset Timer” input is not required for this example since the “Timer Start” input both clears and starts the timer.

Counter Function

Digital inputs and outputs control the counter function and are configured with parameters A051...A054 [Digital Inx Sel] set to 19 “Counter In” and 21 “Reset Counter”.

Digital outputs (relay and opto type) define a preset level and indicate when the level is reached. Level parameters A056 [Relay Out Level], A059 [Opto Out1 Level], and A062 [Opto Out2 Level] are used to set the desired count value.

Parameters A055 [Relay Out Sel], A058 [Opto Out1 Sel] and A061 [Opto Out2 Sel] are set to 17 “Counter Out” which causes the output to change state when the level is reached.

Example

- A photo eye is used to count packages on a conveyor line.
- An accumulator holds the packages until 5 are collected.
- A diverter arm redirects the group of 5 packages to a bundling area.
- The diverter arm returns to its original position and triggers a limit switch that resets the counter.
- Parameters are set to the following options:
 - A051 [Digital In1 Sel] set to 19 to select “Counter In”
 - A052 [Digital In2 Sel] set to 21 to select “Reset Counter”
 - A055 [Relay Out Sel] set to 17 to select “Counter Out”
 - A056 [Relay Out Level] set to 5.0 (counts)

StepLogic Parameters

Table 12 – Code Descriptions for Parameters A140...A147

Digit 3	Digit 2	Digit 1	Digit 0
0	0	F	1

Table 13 – Digit 3 – Defines the action during the step currently executing.

Setting	Accel/Decel Parameters Used	StepLogic Output State	Commanded Direction
0	1	Off	FWD
1	1	Off	REV
2	1	Off	No Output
3	1	On	FWD
4	1	On	REV
5	1	On	No Output
6	2	Off	FWD
7	2	Off	REV
8	2	Off	No Output
9	2	On	FWD
A	2	On	REV
b	2	On	No Output

Table 14 – Digit 2 – Defines what step to jump to or how to end program when the logic conditions specified in Digit 1 are met.

Setting	Logic
0	Jump to Step 0
1	Jump to Step 1
2	Jump to Step 2
3	Jump to Step 3
4	Jump to Step 4
5	Jump to Step 5
6	Jump to Step 6
7	Jump to Step 7
8	End Program (Normal Stop)
9	End Program (Coast to Stop)
A	End Program and Fault (F2)

Table 15 – Digit 1 – Defines what logic must be met to jump to a step other than the very next step.

Setting	Description	Logic
0	Skip Step (jump immediately)	SKIP
1	Step based on the time programmed in the respective [Stp Logic Time x] parameter.	TIMED
2	Step if "Logic In1" is active (logically true)	TRUE
3	Step if "Logic In2" is active (logically true)	TRUE
4	Step if "Logic In1" is not active (logically false)	FALSE
5	Step if "Logic In2" is not active (logically false)	FALSE
6	Step if either "Logic In1" or "Logic In2" is active (logically true)	OR
7	Step if both "Logic In1" and "Logic In2" is active (logically true)	AND
8	Step if neither "Logic In1" or "Logic In2" is active (logically true)	NOR
9	Step if "Logic In1" is active (logically true) and "Logic In2" is not active (logically false)	XOR
A	Step if "Logic In2" is active (logically true) and "Logic In1" is not active (logically false)	XOR
b	Step after [Stp Logic Time x] and "Logic In1" is active (logically true)	TIMED AND
C	Step after [Stp Logic Time x] and "Logic In2" is active (logically true)	TIMED AND
d	Step after [Stp Logic Time x] and "Logic In1" is not active (logically false)	TIMED OR
E	Step after [Stp Logic Time x] and "Logic In2" is not active (logically false)	TIMED OR
F	Do not step OR no "jump to", so use Digit 0 logic	IGNORE

Table 16 – Digit 0 – Defines what logic must be met to jump to the very next step.

Setting	Description	Logic
0	Skip Step (jump immediately)	SKIP
1	Step based on the time programmed in the respective [Stp Logic Time x] parameter.	TIMED
2	Step if "Logic In1" is active (logically true)	TRUE
3	Step if "Logic In2" is active (logically true)	TRUE
4	Step if "Logic In1" is not active (logically false)	FALSE
5	Step if "Logic In2" is not active (logically false)	FALSE
6	Step if either "Logic In1" or "Logic In2" is active (logically true)	OR
7	Step if both "Logic In1" and "Logic In2" is active (logically true)	AND
8	Step if neither "Logic In1" or "Logic In2" is active (logically true)	NOR
9	Step if "Logic In1" is active (logically true) and "Logic In2" is not active (logically false)	XOR
A	Step if "Logic In2" is active (logically true) and "Logic In1" is not active (logically false)	XOR
b	Step after [Stp Logic Time x] and "Logic In1" is active (logically true)	TIMED AND
C	Step after [Stp Logic Time x] and "Logic In2" is active (logically true)	TIMED AND
d	Step after [Stp Logic Time x] and "Logic In1" is not active (logically false)	TIMED OR
E	Step after [Stp Logic Time x] and "Logic In2" is not active (logically false)	TIMED OR
F	Use logic programmed in Digit 1	IGNORE

PID Set Up

PID Loop

The PowerFlex 40 has a built-in PID (proportional, integral, differential) control loop. The PID loop is used to maintain a process feedback (such as pressure, flow or tension) at a desired set point. The PID loop works by subtracting the PID feedback from a reference and generating an error value. The PID loop reacts to the error, based on the PID Gains, and outputs a frequency to try to reduce the error value to 0. To enable the PID loop, parameter A132 [PID Ref Sel] must be set to an option other than 0 “PID Disabled”.

Exclusive Control and Trim Control are two basic configurations where the PID loop may be used.

Exclusive Control

In Exclusive Control, the Speed Reference becomes 0, and the PID Output becomes the entire Freq Command. Exclusive Control is used when A132 [PID Ref Sel] is set to option 1, 2, 3, or 4. This configuration does not require a master reference, only a desired set point, such as a flow rate for a pump.

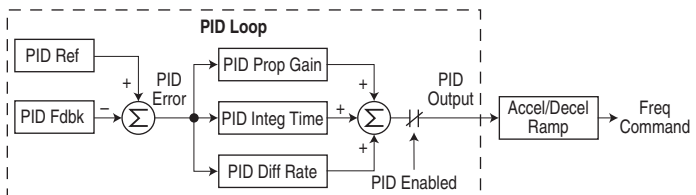

Example

- In a pumping application, the PID Reference equals the Desired System Pressure set point.
- The Pressure Transducer signal provides PID Feedback to the drive. Fluctuations in actual system pressure, due to changes in flow, result in a PID Error value.

- The drive output frequency increases or decreases to vary motor shaft speed to correct for the PID Error value.
- The Desired System Pressure set point is maintained as valves in the system are opened and closed causing changes in flow.
- When the PID Control Loop is disabled, the Commanded Speed is the Ramped Speed Reference.

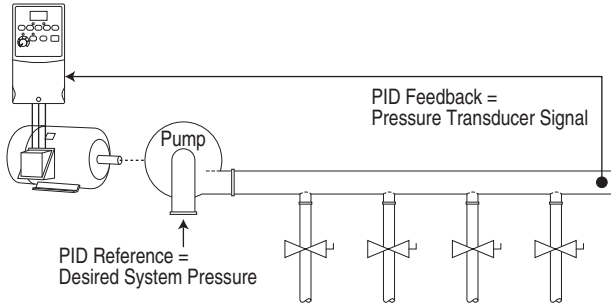

Trim Control

In Trim Control, the PID Output is added to the Speed Reference. In Trim mode, the output of the PID loop bypasses the accel/decel ramp as shown. Trim Control is used when A132 [PID Ref Sel] is set to option 5, 6, 7, or 8.

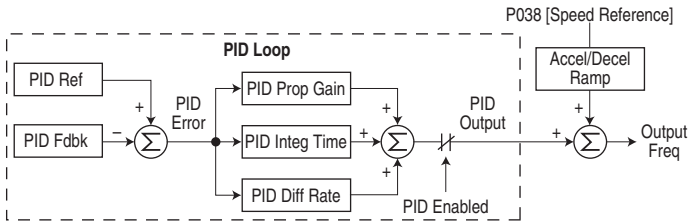

Example

- In a winder application, the PID Reference equals the Equilibrium set point.
- The Dancer Pot signal provides PID Feedback to the drive. Fluctuations in tension result in a PID Error value.
- The Master Speed Reference sets the wind/unwind speed.
- As tension increases or decreases during winding, the Speed Reference is trimmed to compensate. Tension is maintained near the Equilibrium set point.

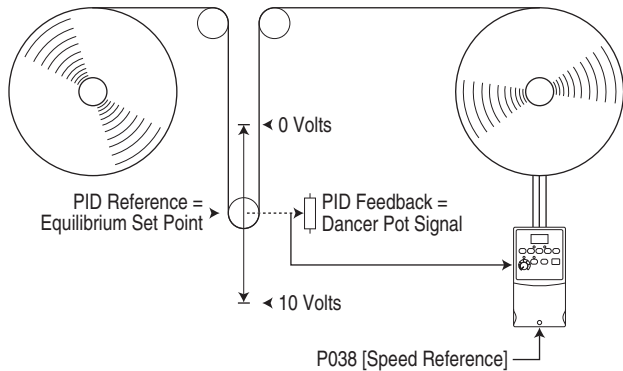

PID Reference and Feedback

Parameter A132 [PID Ref Sel] is used to enable the PID mode (A132 ≠ 0 “PID Disabled”) and to select the source of the PID Reference. If A132 [PID Ref Sel] is not set to 0 “PID Disabled”, PID can still be disabled by select programmable digital input options (parameters [A051...A054](#)) such as “Jog”, “Local” or “PID Disable”.

Table 17 – A132 [PID Ref Sel] Options

Option	Description
0 “PID Disabled”	Disables the PID loop (default setting)
1 “PID Setpoint”	Selects Exclusive Control. A137 [PID Setpoint] will be used to set the value of the PID Reference
2 “0-10V Input”	Selects Exclusive Control. Selects the 0...10V Input. Note that the PID will not function with a bipolar analog input. It will ignore any negative voltages and treat them like a zero.
3 “4-20mA Input”	Selects Exclusive Control. Selects the 4...20 mA Input.
4 “Comm Port”	Selects Exclusive Control. The reference word from a communication network (see Appendix C for details on the reference word) such as Modbus RTU or DeviceNet becomes the PID Reference. The value sent over the network is scaled so that P035 [Maximum Freq] x 10 = 100% reference. For example, with [Maximum Freq] = 60 Hz, a value of 600 sent over the network would represent 100% reference.
5 “Setpt, Trim”	Selects Trim Control. A137 [PID Setpoint] will be used to set the value of the PID Reference.
6 “0-10V, Trim”	Selects Trim Control. Selects the 0...10V Input. Note that the PID will not function with a bipolar analog input. It will ignore any negative voltages and treat them like a zero.
7 “4-20mA, Trim”	Selects Trim Control. Selects the 4...20mA Input.
8 “Comm, Trim”	Selects Trim Control. The reference word from a communication network (see Appendix C for details on the reference word) such as Modbus RTU or DeviceNet becomes the PID Reference. The value sent over the network is scaled so that P035 [Maximum Freq] x 10 = 100% reference. For example, with [Maximum Freq] = 60 Hz, a value of 600 sent over the network would represent 100% reference.

A133 [PID Feedback Sel] is used to select the source of the PID feedback.

Table 18 – A133 [PID Feedback Sel] Options

Option	Description
0 “0-10V Input”	Selects the 0...10V Input (default setting). Note that the PID will not function with a bipolar analog input. It ignores any negative voltages and treat them like a zero.
1 “4-20mA Input”	Selects the 4...20 mA Input.
2 “Comm Port”	The reference word from a communication network (see Appendix C of the PowerFlex 40 User Manual for details on the reference word) such as Modbus RTU or DeviceNet becomes the PID Feedback. The value sent over the network is scaled so that P035 [Maximum Freq] x 10 = 100% Feedback. For example, with [Maximum Freq] = 60 Hz, a value of 600 sent over the network would represent 100% Feedback.

Analog PID Reference Signals

Parameters A110 [Anlg In 0-10V Lo] and A111 [Anlg In 0-10V Hi] are used to scale or invert an analog PID Reference.

Important: Firmware version FRN 2.xx also allows PID Feedback scaling from an analog input.

Examples

Scale Function

For a 0...5 volt signal, the following parameter settings are used so that a 0 volt signal = 0% PID Reference and a 5 volt signal = 100% PID Reference.

- A110 [Anlg In 0-10V Lo] = 0.0%
- A111 [Anlg In 0-10V Hi] = 50.0%
- A132 [PID Ref Sel] = 0 "0-10V Input"

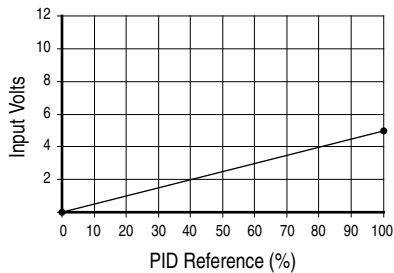

Invert Function

For a 4...20 mA signal, the following parameter settings are used so that a 20 mA signal = 0% PID Reference and a 4 mA signal = 100% PID Reference.

- A112 [Anlg In 4-20mA Lo] = 100.0%
- A113 [Anlg In 4-20mA Hi] = 0.0%
- A132 [PID Ref Sel] = 3 “4-20mA Input”

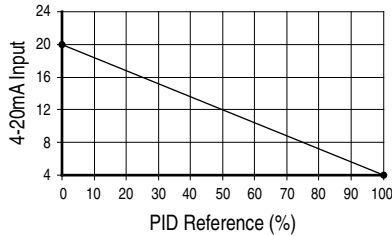

Alternatively, you can set the value of A167 [PID Invert Error] to 1 to change the sign of the PID error. See [A167](#) [PID Invert Error] in Chapter 3 for more details.

PID Deadband

Parameter A138 [PID Deadband] is used to set a range, in percent, of the PID Reference that the drive will ignore.

Example

- [PID Deadband] is set to 5.0
- The PID Reference is 25.0%
- The PID Regulator will not act on a PID Error that falls between 20.0 and 30.0%

PID Preload

The value set in A139 [PID Preload], in Hertz, will be pre-loaded into the integral component of the PID at any start or enable. This will cause the drive's frequency command to initially jump to that preload frequency, and the PID loop starts regulating from there.

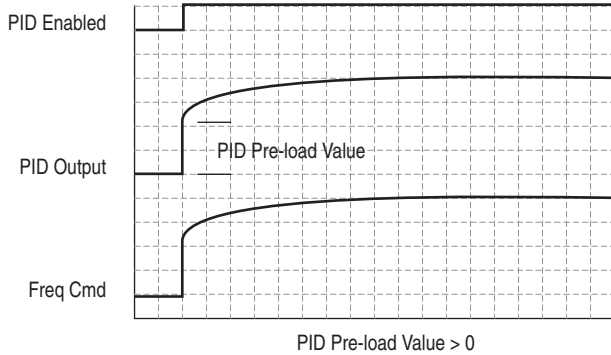

PID Limits

A130 [PID Trim Hi] and A131 [PID Trim Lo] are used to limit the PID output and are only used in trim mode. [PID Trim Hi] sets the maximum frequency for the PID output in trim mode. [PID Trim Lo] sets the reverse frequency limit for the PID output in trim mode. Note that when the PID reaches the Hi or Lo limit, the PID regulator stops integrating so that windup does not occur.

PID Gains

The proportional, integral, and differential gains make up the PID regulator.

- A134 [PID Prop Gain]
The proportional gain (unitless) affects how the regulator reacts to the magnitude of the error. The proportional component of the PID regulator outputs a speed command proportional to the PID error. For example, a proportional gain of 1 would output 100% of max frequency when the PID error is 100% of the analog input range. A larger value for [PID Prop Gain] makes the proportional component more responsive, and a smaller value makes it less responsive. Setting [PID Prop Gain] to 0.00 disables the proportional component of the PID loop.
- A135 [PID Integ Time]
The integral gain (units of seconds) affects how the regulator reacts to error over time and is used to get rid of steady state error. For example, with an integral gain of 2 seconds, the output of the integral gain component would integrate up to 100% of max frequency when the PID error is 100% for 2 seconds. A larger value for [PID Integ Time] makes the integral component less responsive, and a smaller value makes it more responsive. Setting [PID Integ Time] to 0 disables the integral component of the PID loop.
- A136 [PID Diff Rate]
The Differential gain (units of 1/seconds) affects the rate of change of the PID output. The differential gain is multiplied by the difference between the previous error and current error. Thus, with a large error the D has a large effect and with a small error the D has less of an effect. This parameter is scaled so that when it is set to 1.00, the process response is 0.1% of [Maximum Freq] when the process error is changing at 1% / second. A larger value for [PID Diff Rate] makes the differential term have more of an effect and a small value makes it have less of an effect. In many applications, the D gain is not needed. Setting [PID Diff Rate] to 0.00 (factory default) disables the differential component of the PID loop.

Guidelines for Adjusting the PID Gains

1. Adjust the proportional gain. During this step it may be desirable to disable the integral gain and differential gain by setting them to 0. After a step change in the PID Feedback:
 - If the response is too slow increase A134 [PID Prop Gain].
 - If the response is too quick and/or unstable (see [Figure 17](#)), decrease A134 [PID Prop Gain].
 - Typically, A134 [PID Prop Gain] is set to some value below the point where the PID begins to go unstable.
2. Adjust the integral gain (leave the proportional gain set as in Step 1). After a step change in the PID Feedback:
 - If the response is too slow (see [Figure 18](#)), or the PID Feedback does not become equal to the PID Reference, decrease A135 [PID Integ Time].
 - If there is a lot of oscillation in the PID Feedback before settling out (see [Figure 19](#)), increase A135 [PID Integ Time].
3. At this point, the differential gain may not be needed. However, if after determining the values for A134 [PID Prop Gain] and A135 [PID Integ Time]:
 - Response is still slow after a step change, increase A136 [PID Diff Rate].
 - Response is still unstable, decrease A136 [PID Diff Rate].

The following figures show some typical responses of the PID loop at different points during adjustment of the PID Gains.

Figure 17 Unstable

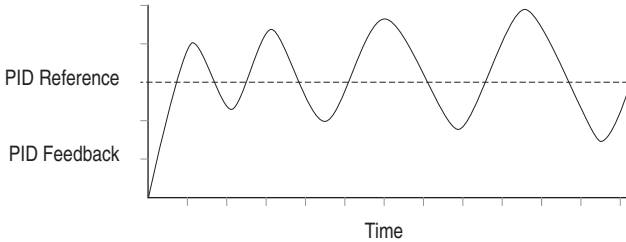

Figure 18 Slow Response – Over Damped

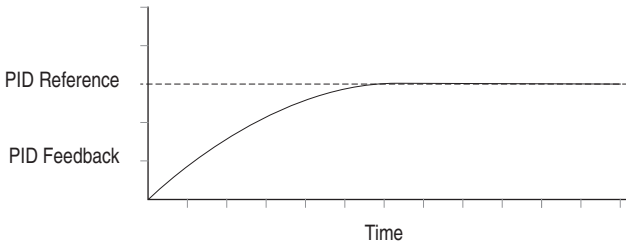

Figure 19 Oscillation – Under Damped

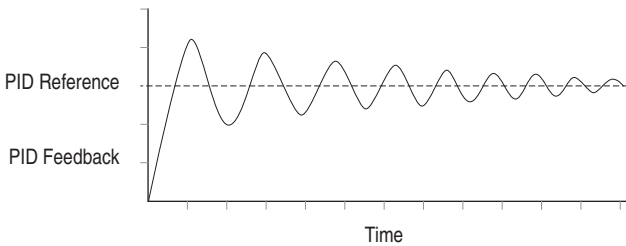
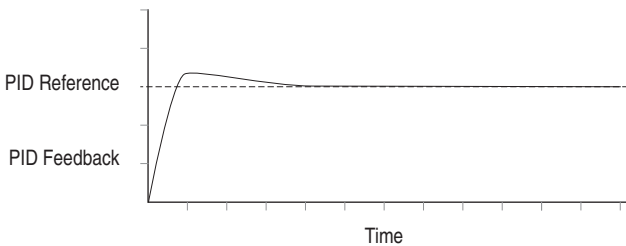

Figure 20 Good Response – Critically Damped



A

AC Supply
 Ground, **16**
 Source, **14**
 Ungrounded, **14**
Acceleration Rate, **34**
Advanced Program Group
 Parameters, **58**
Ambient Temperatures, **13**
Analog Input Loss Fault, F29, **93**
Armored Cable, **20**
Auto Rstrt Tries Fault, F33, **94**
Auxiliary Input Fault, F2, **93**

B

Before Applying Power, **37**
Bus Capacitors, Discharging, **9, 12**

C

Cable Length, **25**
Cable, Power, **20**
Capacitors, Discharging, **9, 12**
Catalog Number Explanation, **10**
CE Conformity, **35**
Checklist, Start-Up, **37**
Circuit Breakers, **17**
Comm Loss Fault, F81, **94**
Command Sources for Start and
 Speed, **33**
Common Symptoms and Corrective
 Action, **95**
Connected Components Workbench,
 45
Contactors, **24**
Control Wiring, **26**
Control, 2 and 3 Wire, **28**
Conventions, Manual, **8**
Cover, Opening, **11**
Cross Reference, Parameter
 by Name, **89**

D

Data, Diagnostic, **43**

Data, Saving, **43**
Deceleration Rate, **34**
Dimensions
 Drive, **110**
 Minimum Clearances, **13**
Direction
 of Drive, **38**
 of Motor, **23**
Discharging Bus Capacitors, **9, 12**
Disconnecting Output Power, **22**
Display, **40**
Display Group Parameters, **47**
Distribution Systems, Ungrounded,
 14
Drive Frame Size, **8, 110**
Drive Grounding, **16**
Drive Overload Fault, F64, **94**
Drive Ratings, **10, 99**
DriveExecutive, **45**

E

Earthing, *see* *Grounding*
Edit Parameters, **41**
EMC/RFI
 Grounding, Filter, **17**
 Interference, **35**
Enclosure Rating, Changing, **13**
ESD, Static Discharge, **9**

F

Faults
 Analog Input Loss, F29, **93**
 Auto Rstrt Tries, F33, **94**
 Auxiliary Input, F2, **93**
 Comm Loss, F81, **94**
 Drive Overload, F64, **94**
 Ground Fault, F13, **93**
 Heatsink OvrTmp, F8, **93**
 HW OverCurrent, F12, **93**
 I/O Board Fail, F122, **95**
 Motor Overload, F7, **93**
 Motor Stalled, F6, **93**

- Net Loss, F71, **94**
- OverVoltage, F5, **93**
- Parameter Checksum, F100, **94**
- Params Defaulted, F48, **94**
- Phase Short, F41-F43, **94**
- Phase to Ground Short, F38-F40, **94**
- Power Loss, F3, **93**
- Power Unit, F70, **94**
- SVC Autotune, F80, **94**
- SW OverCurrent, F63, **94**
- UnderVoltage, F4, **93**
- File
 - Monitor, **47**
- Filter, RFI, **17**
- Frame Designations, **8, 99, 110**
- Fuses
 - Minimum Recommendations, **17**
 - Ratings, **99**
- G**
- General Precautions, **9**
- Ground Fault, F13, **93**
- Grounding
 - Filter, **17**
 - General, **16**
- H**
- Heatsink OvrTmp Fault, F8, **93**
- HW OverCurrent Fault, F12, **93**
- I**
- I/O
 - Block Diagram, **26**
 - Terminal Block, **25**
 - Terminal Designations, **27**
 - Wiring, **24**
 - Wiring Examples, **28**
 - Wiring Multiple Drives, **32**
- I/O Board Fail Fault, F122, **95**
- Input Contactor, **24**
- Input Fusing, **17**
- Input Potentiometer, **28**
- Input Power Conditioning, **15**
- Installation of Drive, **11**
- Integral Keypad, **40**
- Interference, EMC/RFI, **35**
- IP66 Installations, **24**
- K**
- Keypad, **40**
- L**
- LEDs, **40**
- M**
- Menu Structure, **42**
- Minimum Clearances, **13**
- Monitor File, **47**
- Motor
 - Cable Length, **22**
 - Changing Forward Direction of, **23**
 - Disconnect, **22**
- Motor Overload Fault, F7, **93**
- Motor Stalled Fault, F6, **93**
- Motor Starter, Bulletin 140M, **17**
- Mounting Options and Clearances, **13**
- MOV Jumper Location and Removal, **14**
- N**
- NEMA/UL Type 4X Installations, **24**
- Net Loss Fault, F71, **94**
- O**
- Opening the Drive Cover, **11**
- Operating Temperatures, **13**
- Operator Interface, **40**
- Output Disconnect, **22**
- OverVoltage Fault, F5, **93**
- P**
- Parameter
 - Descriptions, **45**
 - Types, **45**
 - Viewing and Editing, **41, 42**
- Parameter Checksum Fault, F100, **94**
- Parameter Cross Reference

by Name, **89**

Parameters

- Advanced Program Group, **58**
- Display Group, **47**
- Program Group, **53**

Params Defaulted Fault, F48, **94**

PE Ground, **16**

Phase Short Fault, F41-F43, **94**

Phase to Ground Fault, F38-F40, **94**

Potentiometer, Wiring, **28**

Power Conditioning, **15**

Power Loss Fault, F3, **93**

Power Unit Fault, F70, **94**

Powering Up the Drive, **37**

Precautions, General, **9**

Preferences, Setting, **43**

Product Selection, **105**

Program Group Parameters, **53**

Programming, **45**

PTC Analog Input Wiring, **28**

R

Ratings, **99**

Reflective Wave Protection, **22**

Removing Cover, **11**

Repeated Start/Stop, **24**

Repeated Start/Stop Precautions, **24**

RFI, see *EMC/RFI*

RWR (Reflective Wave Reducer), **22**

S

Safety Ground, **16**

Saving Data, Viewing, **43**

Setting Preferences, **43**

Shielded Power Cables, **20**

Short Circuit Protection, **17**

Sink/Source, **27**

Software, **45**

Speed, Control of, **38**

Start and Speed Reference Selection and Control, **33**

Start/Stop

- Drive, **38**

Motor, **24**

Starting/Stopping, The Motor, **24**

Start-Up Checklist, **37**

Static Discharge, ESD, **9**

Status LEDs, **40**

Supply Source, AC, **14**

SVC Autotune Fault, F80, **94**

SW OverCurrent Fault, F63, **94**

System Grounding, **16**

T

Terminal Block

- I/O, **25**
- Power, **23**

Three Wire Control, **28**

Two Wire Control, **28**

U

UnderVoltage Fault, F4, **93**

Ungrounded Supply, **14**

Unshielded Power Cables, **20**

W

Wiring, **11**

- Block Diagram, **26**
- Examples, **28**
- I/O Terminal Descriptions, **27**
- Potentiometer, **28**
- PTC Example, **28**
- Recommendations, **24**

Notes:

Rockwell Automation Support

Use these resources to access support information.

Technical Support Center	Find help with how-to videos, FAQs, chat, user forums, Knowledgebase, and product notification updates.	rok.auto/support
Local Technical Support Phone Numbers	Locate the telephone number for your country.	rok.auto/phonesupport
Technical Documentation Center	Quickly access and download technical specifications, installation instructions, and user manuals.	rok.auto/techdocs
Literature Library	Find installation instructions, manuals, brochures, and technical data publications.	rok.auto/literature
Product Compatibility and Download Center (PCDC)	Download firmware, associated files (such as AOP, EDS, and DTM), and access product release notes.	rok.auto/pcdc

Documentation Feedback

Your comments help us serve your documentation needs better. If you have any suggestions on how to improve our content, complete the form at rok.auto/docfeedback.

Waste Electrical and Electronic Equipment (WEEE)



At the end of life, this equipment should be collected separately from any unsorted municipal waste.

Rockwell Automation maintains current product environmental compliance information on its website at rok.auto/pec.





Allen-Bradley, Compact I/O, Connected Components Workbench, DriveExecutive, DriveTools SP, expanding human possibility, PanelView, PowerFlex, Rockwell Automation, SLC, StepLogic, and TechConnect are trademarks of Rockwell Automation, Inc.

ControlNet, DeviceNet, and EtherNet/IP are trademarks of ODVA, Inc.

Microsoft Windows is a trademark of Microsoft, Inc.

Trademarks not belonging to Rockwell Automation are property of their respective companies.

Rockwell Otomasyon Ticaret A.Ş. Kar Plaza İş Merkezi E Blok Kat:6 34752, İçerenköy, İstanbul, Tel: +90 (216) 5698400 EEE Yönetmeliğine Uygundur

Connect with us.    

rockwellautomation.com — expanding **human possibility**[®]

AMERICAS: Rockwell Automation, 1201 South Second Street, Milwaukee, WI 53204-2496 USA, Tel: (1) 414.382.2000

EUROPE/MIDDLE EAST/AFRICA: Rockwell Automation NV, Pegasus Park, De Kleetlaan 12a, 1831 Diegem, Belgium, Tel: (32) 2663 0600

ASIA PACIFIC: Rockwell Automation SEA Pte Ltd, 2 Corporation Road, #04-05, Main Lobby, Corporation Place, Singapore 618494, Tel: (65) 6510 6608

UNITED KINGDOM: Rockwell Automation Ltd., Pitfield, Kiln Farm, Milton Keynes, MK11 3DR, United Kingdom, Tel: (44)(1908) 838-800

Publication 22B-UM001J-EN-E - September 2025

Supersedes Publication 22B-UM001I-EN-E - June 2017

Copyright © 2025 Rockwell Automation, Inc. All rights reserved.