

SIEMENS

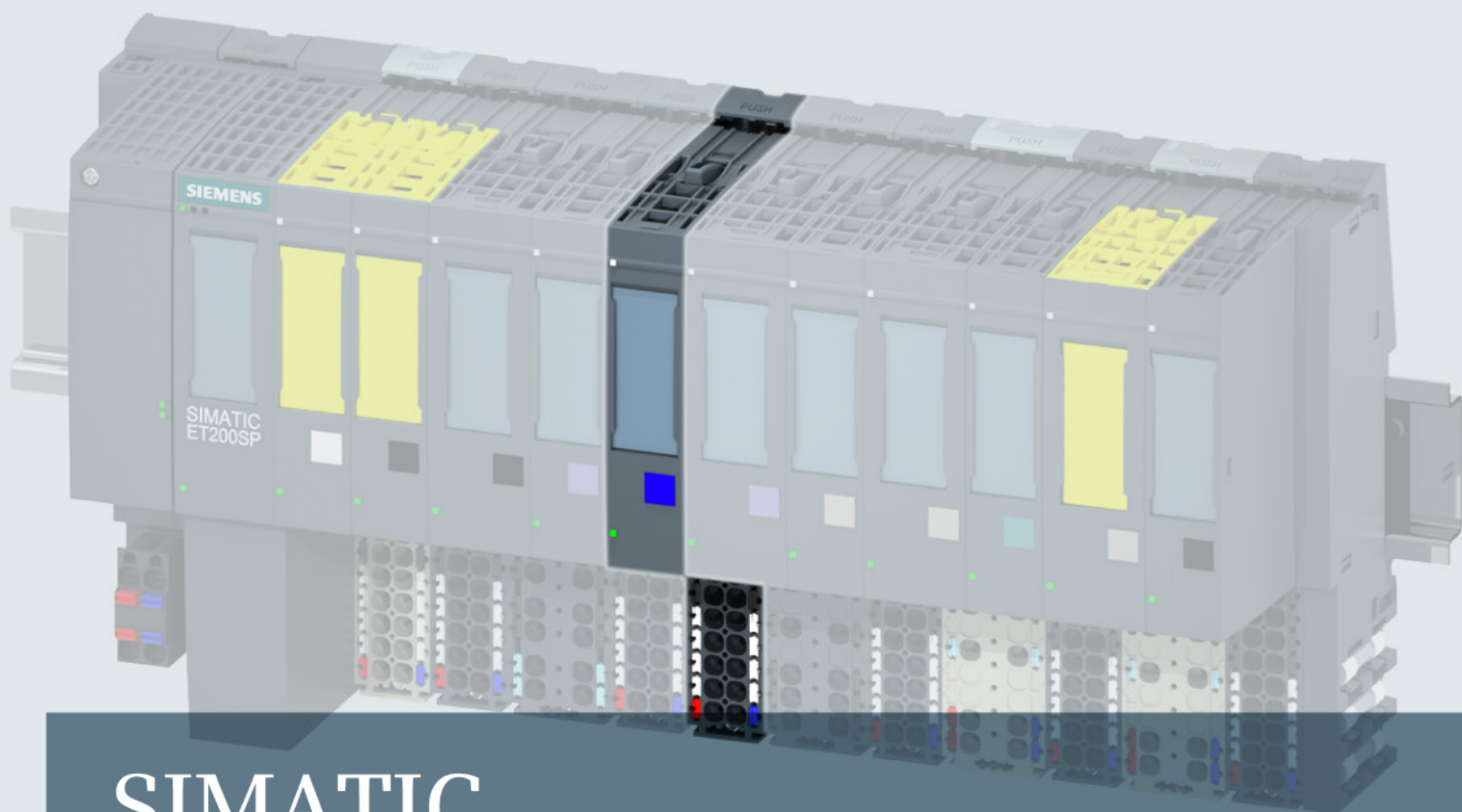

SIMATIC

ET 200SP

Analog output module AQ 4xU/I ST (6ES7135-6HD00-0BA1)

Manual

Edition

07/2014

Answers for industry.

SIEMENS

SIMATIC

ET 200SP

Analog Output Module AQ 4xU/I ST (6ES7135-6HD00-0BA1)

Manual

Preface

Documentation guide

1

Product overview

2

Wiring up

3

Parameters/address space

4

Interrupts/diagnostics alarms

5

Technical specifications

6

Parameter data record

A



Representation of analog values

B

Legal information

Warning notice system

This manual contains notices you have to observe in order to ensure your personal safety, as well as to prevent damage to property. The notices referring to your personal safety are highlighted in the manual by a safety alert symbol, notices referring only to property damage have no safety alert symbol. These notices shown below are graded according to the degree of danger.

 DANGER
indicates that death or severe personal injury will result if proper precautions are not taken.
 WARNING
indicates that death or severe personal injury may result if proper precautions are not taken.
 CAUTION
indicates that minor personal injury can result if proper precautions are not taken.
NOTICE
indicates that property damage can result if proper precautions are not taken.

If more than one degree of danger is present, the warning notice representing the highest degree of danger will be used. A notice warning of injury to persons with a safety alert symbol may also include a warning relating to property damage.

Qualified Personnel

The product/system described in this documentation may be operated only by **personnel qualified** for the specific task in accordance with the relevant documentation, in particular its warning notices and safety instructions. Qualified personnel are those who, based on their training and experience, are capable of identifying risks and avoiding potential hazards when working with these products/systems.

Proper use of Siemens products

Note the following:

 WARNING
Siemens products may only be used for the applications described in the catalog and in the relevant technical documentation. If products and components from other manufacturers are used, these must be recommended or approved by Siemens. Proper transport, storage, installation, assembly, commissioning, operation and maintenance are required to ensure that the products operate safely and without any problems. The permissible ambient conditions must be complied with. The information in the relevant documentation must be observed.

Trademarks

All names identified by ® are registered trademarks of Siemens AG. The remaining trademarks in this publication may be trademarks whose use by third parties for their own purposes could violate the rights of the owner.

Disclaimer of Liability

We have reviewed the contents of this publication to ensure consistency with the hardware and software described. Since variance cannot be precluded entirely, we cannot guarantee full consistency. However, the information in this publication is reviewed regularly and any necessary corrections are included in subsequent editions.

Preface

Purpose of the documentation

This device manual complements the system manual ET 200SP distributed I/O system (<http://support.automation.siemens.com/WW/view/en/58649293>). Functions that generally relate to the system are described in this manual.

The information provided in this manual and in the system/function manuals supports you in commissioning the system.

Conventions

Please also observe notes marked as follows:

Note

A note contains important information on the product described in the documentation, on the handling of the product and on the section of the documentation to which particular attention should be paid.

Security information

Siemens provides products and solutions with industrial security functions that support the secure operation of plants, solutions, machines, equipment and/or networks. They are important components in a holistic industrial security concept. With this in mind, Siemens' products and solutions undergo continuous development. Siemens recommends strongly that you regularly check for product updates.

For the secure operation of Siemens products and solutions, it is necessary to take suitable preventive action (e.g. cell protection concept) and integrate each component into a holistic, state-of-the-art industrial security concept. Third-party products that may be in use should also be considered. You can find more information about industrial security on the Internet (<http://www.siemens.com/industrialsecurity>).

To stay informed about product updates as they occur, sign up for a product-specific newsletter. You can find more information on the Internet (<http://support.automation.siemens.com>).

Table of contents

	Preface	4
1	Documentation guide	6
2	Product overview	8
	2.1 Properties	8
3	Wiring up	10
	3.1 Terminal assignment	10
	3.2 Schematic circuit diagram	11
4	Parameters/address space	12
	4.1 Output ranges	12
	4.2 Parameters	13
	4.3 Explanation of the parameters	15
	4.4 Address space	16
5	Interrupts/diagnostics alarms	17
	5.1 Status and error display	17
	5.2 Interrupts	19
	5.3 Diagnostics alarms	20
6	Technical specifications	21
	6.1 Technical specifications	21
A	Parameter data record	26
	A.1 Dependencies when configuring with GSD file	26
	A.2 Parameter assignment and structure of the parameter data record	27
B	Representation of analog values	30
	B.1 Representation of output ranges	31
	B.2 Representation of analog values in the voltage output ranges	32
	B.3 Representation of analog values in the current output ranges	34

Documentation guide

The documentation for the SIMATIC ET 200SP distributed I/O system is arranged into three areas.

This arrangement enables you to access the specific content you require.

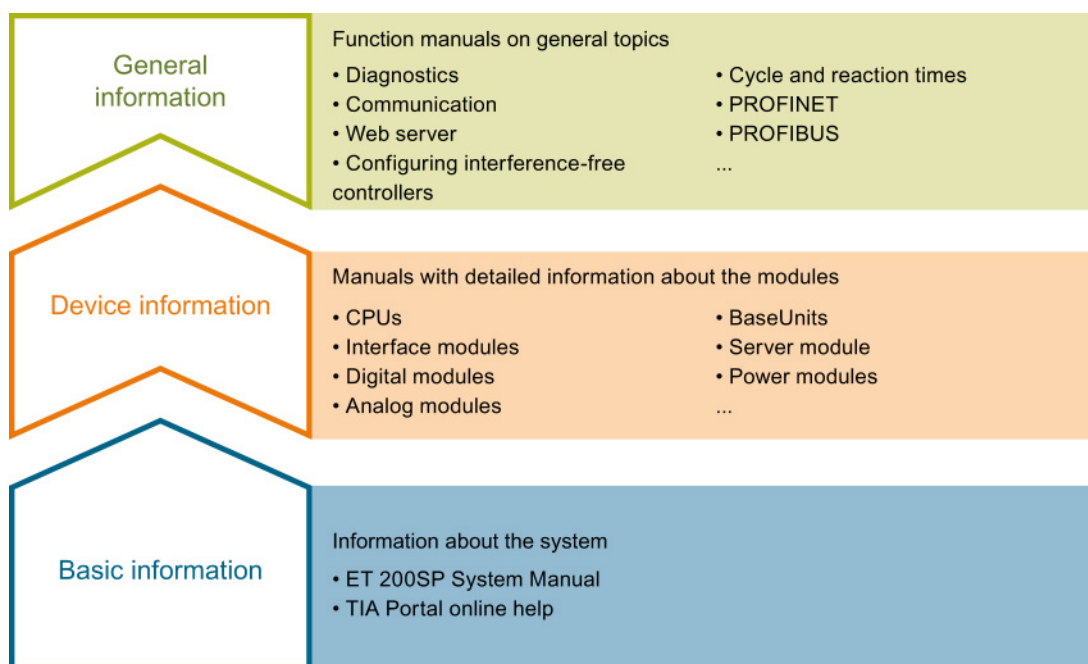

Basic information

The System Manual and Getting Started describe in detail the configuration, installation, wiring and commissioning of the SIMATIC distributed I/O system. ET 200SP. The STEP 7 online help supports you in the configuration and programming.

Device information

Manuals contain a compact description of the module-specific information, such as properties, terminal diagrams, characteristics, technical specifications.

General information

The function manuals contain detailed descriptions on general topics regarding the SIMATIC ET 200SP distributed I/O system, e.g. diagnostics, communication, Motion Control, Web server.

You can download the documentation free of charge from the Internet (<http://w3.siemens.com/mcims/industrial-automation-systems-simatic/en/manual-overview/tech-doc-et200/Pages/Default.aspx>).

Changes and supplements to the manuals are documented in a Product Information.

Manual Collection ET 200SP

The Manual Collection contains the complete documentation on the SIMATIC ET 200SP distributed I/O system gathered together in one file.

You can find the Manual Collection on the Internet (<http://support.automation.siemens.com/WW/view/en/84133942>).

My Documentation Manager

The My Documentation Manager is used to combine entire manuals or only parts of these to your own manual.

You can export the manual as PDF file or in a format that can be edited later.

You can find the My Documentation Manager on the Internet (<http://support.automation.siemens.com/WW/view/en/38715968>).

Applications & Tools

Applications & Tools supports you with various tools and examples for solving your automation tasks. Solutions are shown in interplay with multiple components in the system - separated from the focus in individual products.

You can find Applications & Tools on the Internet (<http://support.automation.siemens.com/WW/view/en/20208582>).

CAx Download Manager

The CAx Download Manager is used to access the current product data for your CAx or CAe systems.

You configure your own download package with a few clicks.

In doing so you can select:

- Product images, 2D dimension drawings, 3D models, internal circuit diagrams, EPLAN macro files
- Manuals, characteristics, operating manuals, certificates
- Product master data

You can find the CAx Download Manager on the Internet (<http://support.automation.siemens.com/WW/view/en/42455541>).

Product overview

2.1 Properties

Article number

6ES7135-6HD00-0BA1

View of the module

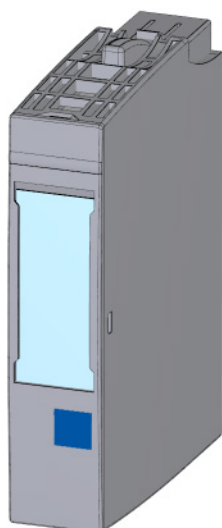

Figure 2-1 View of the module AQ 4xU/I ST

Properties

The module has the following technical properties:

- Analog output module with 4 outputs
 - For current output and
 - voltage output
- Output range for current output:
 - ± 20 mA, resolution 16 bits including sign
 - 0 to 20 mA, resolution 15 bits
 - 4 to 20 mA, resolution 14 bits
- Output range for voltage output:
 - ± 10 V, resolution 16 bits including sign
 - ± 5 V, resolution 15 bits including sign
 - 0 to 10 V, resolution 15 bits
 - 1 to 5 V, resolution 13 bits
- Electrically isolated from supply voltage L+
- Configurable diagnostics per module

The module supports the following functions:

- Firmware update
- I&M identification data
- Configuration in RUN
- PROFlenergy

Table 2- 1 Version dependencies of other module functions

Function	Product version of the module as of	Firmware version of the module as of
Value status	1	V1.1.0

You can configure the module with STEP 7 (TIA Portal) and with a GSD file.

Accessories

The following accessories must be ordered separately:

- Labeling strips
- Color identification labels
- Reference identification label
- Shield connector

See also

You will find additional information on the accessories in the ET 200SP distributed I/O system (<http://support.automation.siemens.com/WWW/view/en/58649293>) system manual.

Wiring up

3.1 Terminal assignment

General terminal assignment

Table 3- 1 Terminal assignment

Terminal assignment for AQ 4×U/I ST (6ES7135-6HD00-0BA1)						
Terminal	Assign-ment	Terminal	Assign-ment	Explanation	BaseUnit ¹	Color identification label
1	Q ₀₊	2	Q ₁₊	<ul style="list-style-type: none"> Q_{n+}: Analog output voltage/current (positive), channel n 	A0 A1	---
3	Q ₂₊	4	Q ₃₊			
5	Q ₀₋	6	Q ₁₋			
7	Q ₂₋	8	Q ₃₋	<ul style="list-style-type: none"> Q_{n-}: Analog output voltage/current (negative), channel n 		
9	S ₀₊	10	S ₁₊			
11	S ₂₊	12	S ₃₊	<ul style="list-style-type: none"> S_{n+}: Sensor line (positive), channel n S_{n-}: Sensor line (negative), channel n 		
13	S ₀₋	14	S ₁₋			
15	S ₂₋	16	S ₃₋			
L+	24 VDC	M	M			

<p>Voltage 2-wire connection</p>	<p>Voltage 4-wire connection</p>	<p>Current</p>
----------------------------------	----------------------------------	----------------

¹ Usable BaseUnit types, can be identified by the last two digits of the article number.

Note

The first BaseUnit of a station must be a light-colored BaseUnit. Also keep this in mind during the configuration.

You will find additional information on the BaseUnit types in the ET 200SP distributed I/O system (<http://support.automation.siemens.com/WWW/view/en/58649293>) system manual.

3.2 Schematic circuit diagram

Schematic circuit diagram

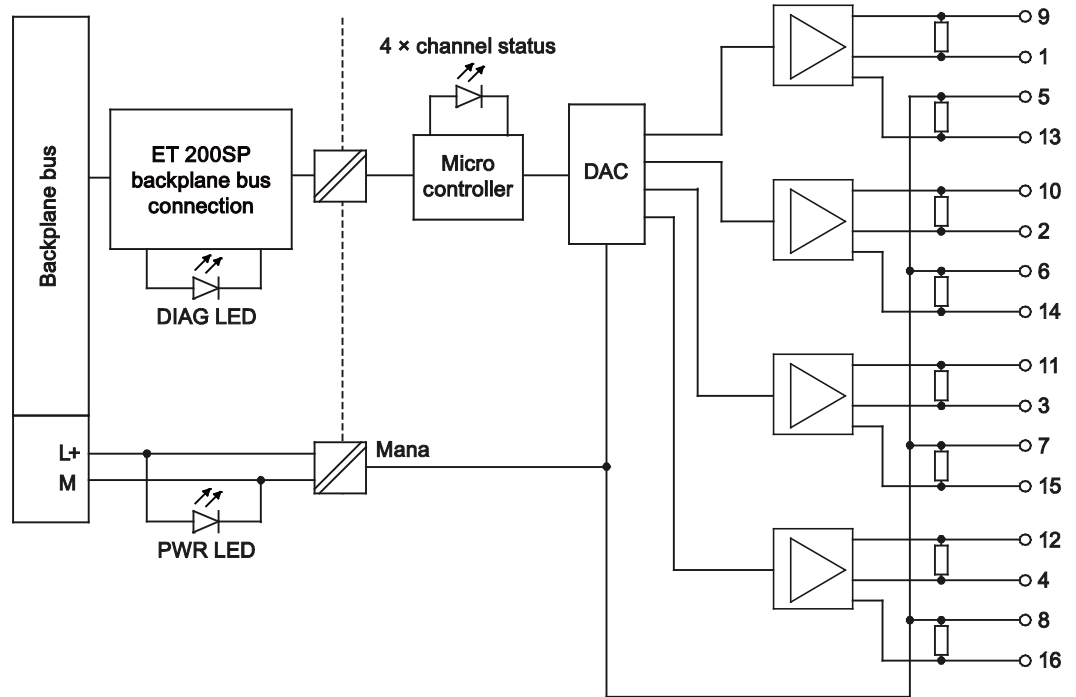

Figure 3-1 Schematic circuit diagram for AQ 4xUI ST

Parameters/address space

4.1 Output ranges

The analog output module AQ 4xU/I ST has the following measuring ranges:

Table 4- 1 Output ranges

Output type	Output ranges	Resolution
Current	± 20 mA	16 bits including sign
	0 to 20 mA	15 bits
	4 to 20 mA	14 bits
Voltage	±10 V	16 bits including sign
	±5 V	15 bits including sign
	0 to 10 V	15 bits
	1 to 5 V	13 bits

The tables of the output ranges, overflow, overrange, etc. can be found in section Representation of analog values (Page 30).

4.2 Parameters

Parameters of the AQ 4xU/I ST

The effective range of the parameters depends on the type of configuration. The following configurations are possible:

- Central operation with an S7-1500 CPU
- Distributed operation on PROFINET IO in an ET 200SP system
- Distributed operation on PROFIBUS DP in an ET 200SP system

When assigning parameters in the user program, use the "WRREC" instruction to transfer the parameters to the module using the data records; refer to the section Parameter assignment and structure of the parameter data record (Page 27).

The following parameter settings are possible:

Table 4- 2 Settable parameters and their defaults (GSD file)

Parameters	Value range	Default	Configuration in RUN	Effective range with configuration software, e.g. STEP 7 (TIA Portal)	
				GSD file PROFINET IO	GSD file PROFIBUS DP
Diagnostics No supply voltage L+	<ul style="list-style-type: none"> • Disable • Enable 	Disable	yes	Module	Module
Diagnostics: Short-circuit ¹	<ul style="list-style-type: none"> • Disable • Enable 	Disable	yes	Module	Module
Diagnostics Overflow	<ul style="list-style-type: none"> • Disable • Enable 	Disable	yes	Module	Module
Diagnostics Underflow	<ul style="list-style-type: none"> • Disable • Enable 	Disable	yes	Module	Module
Diagnostics wire break ²	<ul style="list-style-type: none"> • Disable • Enable 	Disable	yes	Module	Module
Output type/range	<ul style="list-style-type: none"> • deactivated • Voltage +/- 10 V • Voltage +/- 5 V • Voltage 0..10 V • Voltage 1..5 V • Current +/- 20 mA • Current 0 - 20 mA • Current 4 - 20 mA 	Current 4 - 20 mA	yes	Channel	Channel

4.2 Parameters

Parameters	Value range	Default	Configuration in RUN	Effective range with configuration software, e.g. STEP 7 (TIA Portal)	
				GSD file PROFINET IO	GSD file PROFIBUS DP
Reaction to CPU STOP	<ul style="list-style-type: none"> Turn off Keep last value Output substitute value 	Turn off	yes	Channel	Module
Substitute value	For permissible substitute values for the various output ranges, see appendix Parameter data record (Page 26), Substitute values → Codes for substitute value table	0	yes	Channel	Channel
Potential group	<ul style="list-style-type: none"> Use potential group of the left module Allow new potential group 	Use potential group of the left module	no	Module	Module

¹ no diagnostics detection between -0.5 V and +0.5 V (no short-circuit detection)

² no diagnostics detection between -3 mA and +3 mA (no wire break detection)

Note

Unused channels

"Disable" the unused channels in the parameter assignment. This improves the temperature characteristics of the module, see Derating, section Technical specifications (Page 21).

A disabled channel always returns the value "no current or voltage".

4.3 Explanation of the parameters

Diagnostics no supply voltage L+

Enabling of the diagnostics for no or insufficient supply voltage L+.

Diagnostics: Short-circuit

Enabling of the diagnostics when a short-circuit of the actuator supply occurs.

Diagnostics overflow

Enabling of the diagnostics when the output value exceeds the overrange.

Diagnostics underflow

Enabling of the diagnostics when the output value exceeds the overrange, falls below the minimum output value or reaches underflow.

Diagnostics wire break

Enabling of the diagnostics if the line to the actuator is broken.

Output type / output range

See section Output ranges (Page 12)

Reaction to CPU STOP

Determines the behavior of the module at CPU STOP.

Substitute value

The substitute value is the value that the module outputs in case of a CPU STOP.

Potential group

Specifies that a BaseUnit with voltage supply feed-in is located in this slot (see system manual ET 200SP Distributed I/O System (<http://support.automation.siemens.com/WW/view/en/58649293>)).

4.4 Address space

Configuration options

The following configurations are possible:

- Configuration 1: Without value status
- Configuration 2: With value status

Evaluating the value status

If you enable the value status for the analog module, an additional byte is occupied in the input address space. Bits 0 to 3 in this byte are assigned to a channel. They provide information about the validity of the analog value.

Bit = 1: There are no faults/errors on the module.

Bit = 0: Channel is disabled or there is a fault/error on the module.

If a fault/error occurs on a channel with this module, the value status for all channels is 0.

Address space

The following figure shows the assignment of the address space for the AQ 4xU/I ST with value status (Quality Information (QI)). The addresses for the value status are only available if the value status is enabled.

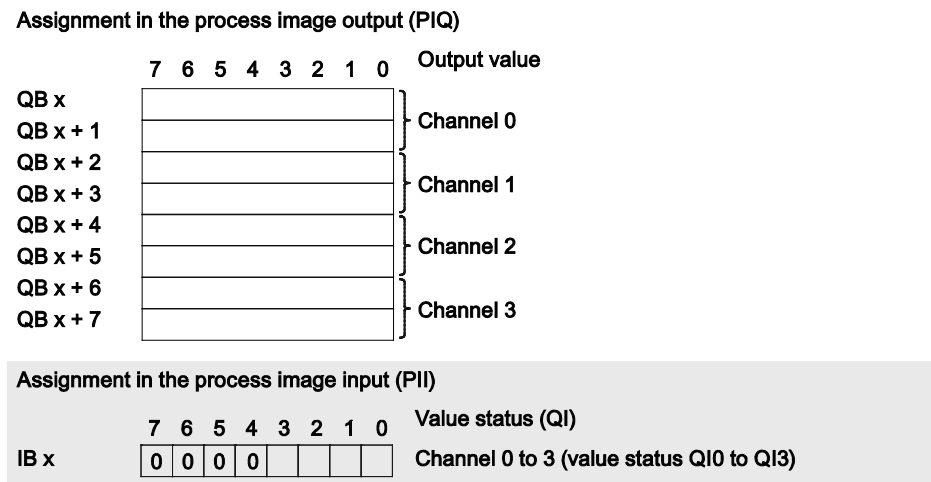

Figure 4-1 Address space of the AQ 4xU/I ST with value status

Interrupts/diagnostics alarms

5.1 Status and error display

LED display

The figure below shows the LED displays of the AQ 4xU/I ST.

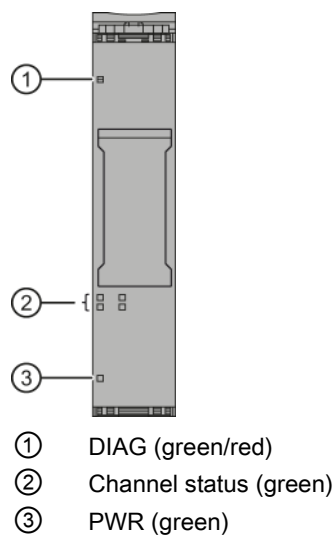

Figure 5-1 LED display

Meaning of the LED displays

The following tables show the meaning of the status and error displays. Measures for dealing with diagnostics alarms can be found in the section Diagnostics alarms (Page 20).

DIAG LED

Table 5- 1 DIAG LED fault/error display

DIAG LED	Meaning
□ off	Backplane bus supply of the ET 200SP not OK
⚡ Flashes	Module parameters not assigned
■ on	Module parameters assigned and no module diagnostics
⚡ Flashes	Module parameters assigned and module diagnostics

Channel status LED

Table 5- 2 Status display of the channel status LED

Channel status LED	Meaning
□ off	Channel disabled
■ on	Channel enabled

PWR LED

Table 5- 3 Status display of the PWR LED

PWR LED	Meaning
□ off	No supply voltage L+
■ on	Supply voltage L+ present

5.2 Interrupts

The analog output module AQ 4xU/I ST supports diagnostic interrupts.

Diagnostics interrupt

The module generates a diagnostics interrupt for the following events:

- Channel temporarily unavailable
- Short-circuit (voltage)
- Overtemperature
- Line break (current)
- High limit violated
- Low limit violated
- Error
- Parameter assignment error
- No load voltage

5.3 Diagnostics alarms

A diagnostics alarm is output for each diagnostics event and the DIAG LED on the module flashes. The diagnostics alarms can, for example, be read from the diagnostics buffer of the CPU. You can evaluate the error codes with the user program.

Table 5- 4 Diagnostics alarms, their meaning and how to deal with them

Diagnostics alarm	Error code	Meaning	Remedy
Channel temporarily unavailable	1FH	Firmware being updated. The module is currently not performing any outputs.	–
		The channel is currently being calibrated.	
Short-circuit	1H	Short-circuit of the actuator supply	Correct the process wiring
Overtemperature	4H	Thermal overload of the I/O module	Correct the process wiring
Wire break	6H	Actuator circuit impedance too high.	Use a different actuator type or wire differently, e.g. use cables with a larger cross-section
		Wire break between the module and actuator	Connect the cable
		Channel not connected (open)	<ul style="list-style-type: none"> • Disable the channel ("output type" parameter) • Connect the channel
High limit violated	7H	The output value specified by the user program exceeds the overrange.	Correct the output value
Low limit violated	8H	The output value specified by the user program is below the underrange.	Correct the output value
Error	9H	Internal module error occurred.	Replace module
Parameter assignment error	10H	<ul style="list-style-type: none"> • The module cannot evaluate parameters for the channel. • Incorrect parameter assignment. 	Correct the parameter assignment
No load voltage	11H	No or insufficient supply voltage L+	<ul style="list-style-type: none"> • Check supply voltage L+ on the BaseUnit • Check BaseUnit type

Technical specifications

6.1 Technical specifications

Technical specifications of AQ 4×U/I ST

	6ES7135-6HD00-0BA1
Product type designation	AQ 4xU/I ST
General information	
Firmware version	V1.1
Usable BaseUnits	BU type A0, A1
Color code for module-specific color identification label	CC00
Product function	
I&M data	Yes
Engineering with	
STEP 7 TIA Portal can be configured/integrated as of version	V11 SP2 / V13
STEP 7 can be configured/integrated as of version	V5.5 SP3 / -
PROFIBUS as of GSD version/GSD revision	GSD revision 5
PROFINET as of GSD version/GSD revision	V2.3 / -
CiR Configuration in RUN	
Configuration in RUN possible	Yes
Installation type/mounting	
Rack mounting possible	Yes
Front installation possible	Yes
Rail mounting possible	Yes
Wall/direct mounting possible	No
Supply voltage	
Type of supply voltage	DC
Rated value (DC)	24 V
Valid range low limit (DC)	19.2 V
Valid range high limit (DC)	28.8 V
Reverse polarity protection	Yes
Input current	
Current consumption, max.	150 mA
Power loss	
Power loss, typ.	1.5 W

6.1 Technical specifications

	6ES7135-6HD00-0BA1
Address area	
Address space per module	
Address space per module, max.	8 bytes; + 1 byte for QI information
Analog outputs	
Number of analog outputs	4
Voltage output, short-circuit current, max.	45 mA
Cycle time (all channels), min.	5 ms
Output ranges, voltage	
0 to 10 V	Yes; 15 bits
1 to 5 V	Yes; 13 bits
-5 to +5 V	Yes; 15 bits including sign
-10 to +10 V	Yes; 16 bits including sign
Output ranges, current	
0 to 20 mA	Yes; 15 bits
-20 to +20 mA	Yes; 16 bits including sign
4 to 20 mA	Yes; 14 bits
Connection of actuators	
for voltage output two-wire connection	Yes
for voltage output four-wire connection	Yes
for current output two-wire connection	Yes
Load resistance (in nominal range of the output)	
For voltage outputs, min.	2 kΩ
For voltage outputs, capacitive load, max.	1 μF
For current outputs, max.	500 Ω
For current outputs, inductive load, max.	1 mH
Destruction limit for externally applied voltages and currents	
Voltages at the outputs	30 V
Cable length	
Cable length shielded, max.	1000 m; 200 m for voltage output
Analog value formation	
Oscillation time	
For resistive load	0.1 ms
For capacitive load	1 ms
For inductive load	0.5 ms
Errors/accuracies	
Linearity error (in relation to output range), (+/-)	± 0.03 %
Temperature error (in relation to output range), (+/-)	0.005 %/K
Crosstalk between outputs, min.	-50 dB
Repeat accuracy in settled state at 25 °C (in relation to output range), (+/-)	± 0.05 %
Operational limit in the entire temperature range	
Voltage in relation to output range, (+/-)	± 0.5 %
Current in relation to output range, (+/-)	± 0.5 %

6ES7135-6HD00-0BA1	
Basic error limit (operational limit at 25 °C)	
Voltage in relation to output range, (+/-)	± 0.3 %
Current in relation to output range, (+/-)	± 0.3 %
Interrupts/diagnostics/status information	
Substitute values can be applied	Yes
Interrupts	
Diagnostics interrupt	Yes
Diagnostics alarms	
Diagnostics	Yes
Monitoring of supply voltage	Yes
Wire break	Yes
Short-circuit	Yes
Overflow/underflow	Yes
Diagnostics display LED	
Monitoring of the supply voltage (PWR LED)	Yes; green LED
Channel status display	Yes; green LED
For module diagnostics	Yes; green/red LED
Electrical isolation	
Electrical isolation of channels	
Between the channels	No
Between the channels and the backplane bus	Yes
Between the channels and the supply voltage of the electronics	Yes
Permitted potential difference	
Between different circuits	75 VDC / 60 VAC (basic isolation)
Insulation	
Insulation tested with	707 VDC (type test)
Environmental conditions	
Operating temperature	
Horizontal installation, min.	0 °C
Horizontal installation, max.	60 °C
Vertical installation, min.	0 °C
Vertical installation, max.	50 °C
Dimensions	
Width	15 mm
Weights	
Weight, approx.	31 g

Derating trends with horizontal installation:

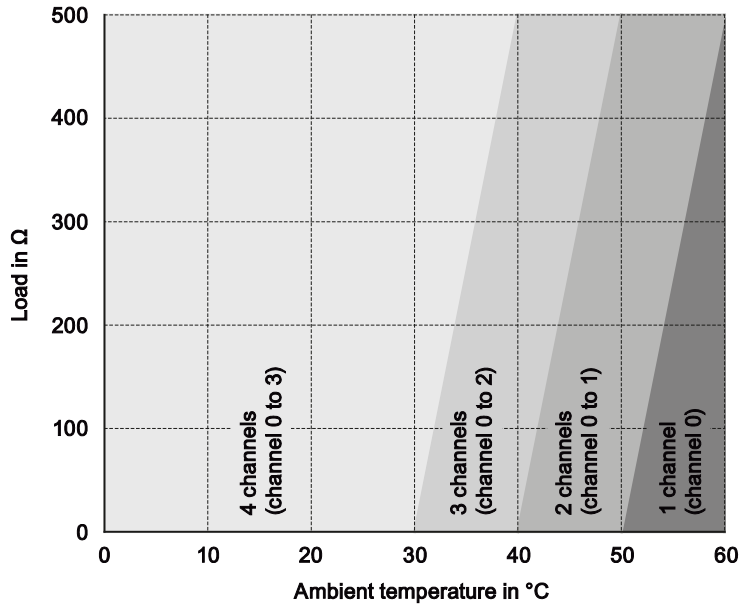

Figure 6-1 Derating trend current output (horizontal)

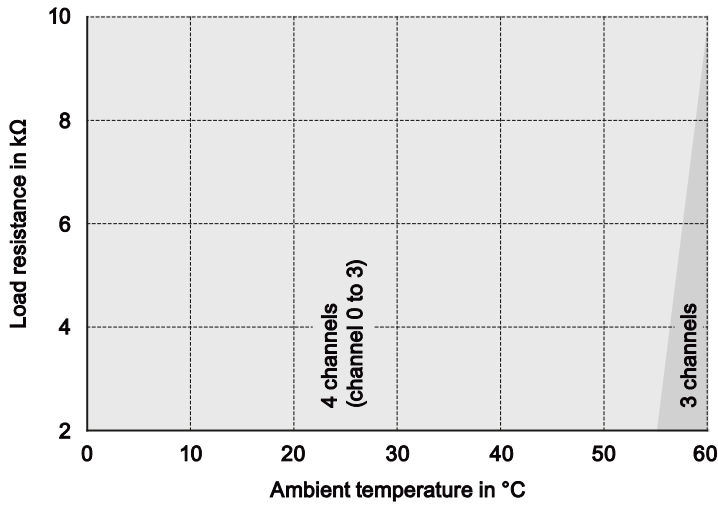

Figure 6-2 Derating trend voltage output (horizontal)

Derating trends with vertical installation:

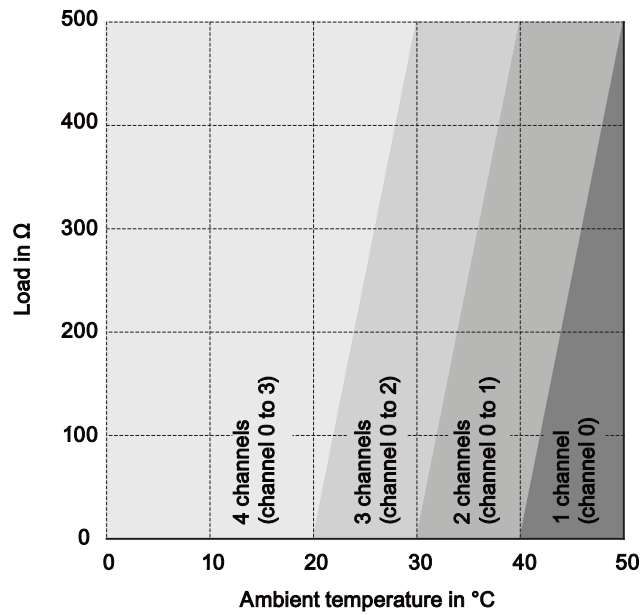

Figure 6-3 Derating trend current output (vertical)

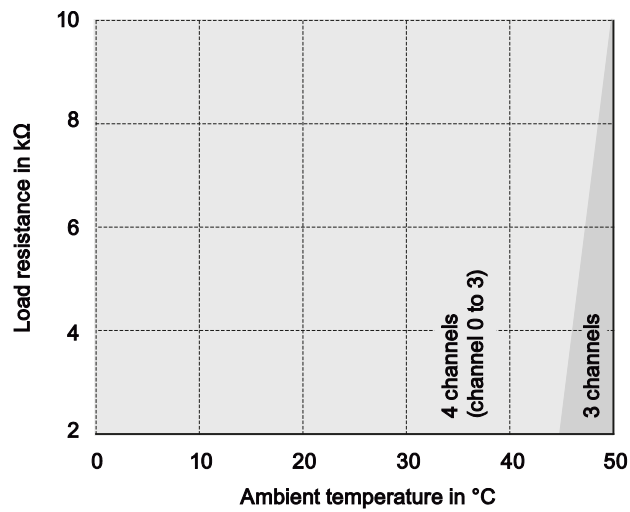

Figure 6-4 Derating trend voltage output (vertical)

Dimension drawing

See manual ET 200SP BaseUnits
(<http://support.automation.siemens.com/WW/view/en/59753521>)

Parameter data record

A.1 Dependencies when configuring with GSD file

When configuring the module with a GSD file, remember that the settings of some parameters are dependent on each other.

Configuring with a PROFINET GSD file

The table lists the properties and their dependencies on the output type and output range for PROFINET.

Output type	Output range	Diagnostics					Reaction to CPU STOP	Substitute value
		No supply voltage L+	Short-circuit to M	Overflow	Underflow	Wire break		
deactivated		*	*	*	*	*	*	*
Voltage	±5 V	x	x	x	x	-	x	x
	±10 V	x	x	x	x	-	x	x
	1.5 V	x	x	x	x	-	x	x
	0..10 V	x	x	x	x	-	x	x
Current	±20 mA	x	-	x	x	x	x	x
	0..20 mA	x	-	x	x	x	x	x
	4..20 mA	x	-	x	x	x	x	x

x = Property is allowed, - = Property is **not allowed**, * = Property is not relevant

Configuring with a PROFIBUS GSD file

The table lists the properties and their dependencies on the output type and output range for PROFIBUS.

Output type	Output range	Diagnostics				Reaction to CPU STOP	Substitute value
		No supply voltage L+	Short-circuit to M	Overflow/ Underflow	Wire break		
deactivated		*	*	*	*	*	*
Voltage	±5 V	x	x	x	-	x	x
	±10 V	x	x	x	-	x	x
	1.5 V	x	x	x	-	x	x
	0..10 V	x	x	x	-	x	x
Current	±20 mA	x	-	x	x	x	x
	0..20 mA	x	-	x	x	x	x
	4..20 mA	x	-	x	x	x	x

x = Property is allowed, - = Property is **not allowed**, * = Property is not relevant

A.2 Parameter assignment and structure of the parameter data record

Parameter assignment in the user program

The module can be re-configured in RUN (for example, the voltage or current values of selected channels can be changed in RUN without having an effect on the other channels).

Changing parameters in RUN

The "WRREC" instruction is used to transfer the parameters to the module using data record 128. The parameters set in STEP 7 are not changed in the CPU, which means that the parameters set in STEP 7 will be valid again after a restart.

Output parameter STATUS

If errors occur when transferring parameters with the "WRREC" instruction, the module continues operation with the previous parameter assignment. The STATUS output parameter contains a corresponding error code.

You will find a description of the "WRREC" instruction and the error codes in the STEP 7 online help.

Structure of data record 128

Note

Channel 0 contains the diagnostics for the entire module.

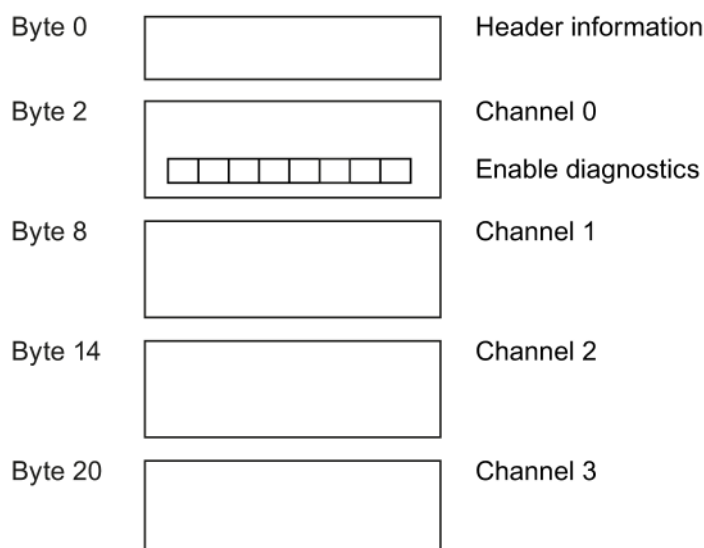

Figure A-1 Structure of data record 128

Header information

The figure below shows the structure of the header information.

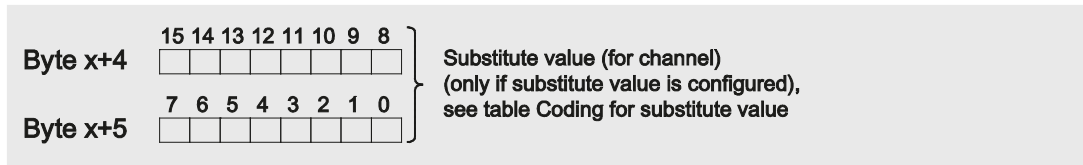
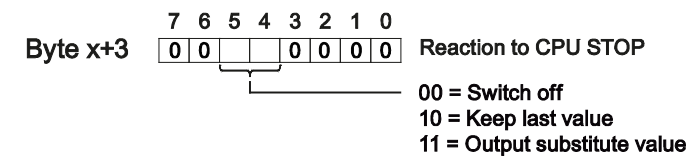
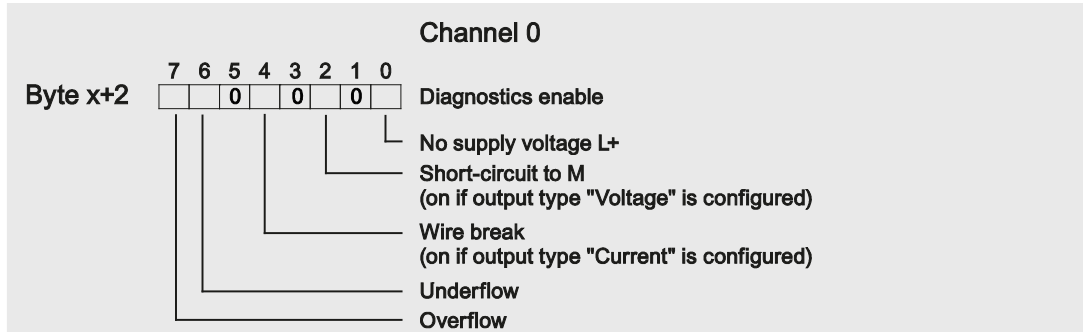
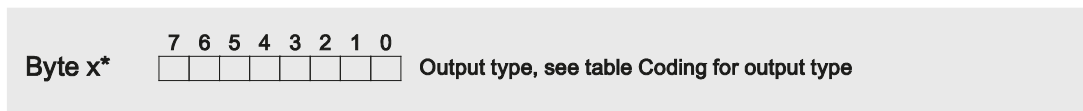

Figure A-2 Header information

Parameters

The figure below shows the structure of the parameters for channels 0 to 3.

You enable a parameter by setting the corresponding bit to "1".



* $x = 2 + (\text{channel number} \times 6)$; channel number = 0 to 3

Figure A-3 Structure byte x up to x+5 for the channel 0 to 3

Codes for output type

The following table contains the codes for the output types of the analog output module. You enter this coding in byte x (see previous figure).

Table A- 1 Codes for output type

Output type	Coding
Deactivated	0000 0000
Voltage	0000 0001
Current	0000 0011

Codes for output range

The following table contains the codes for the output ranges of the analog output module. You enter these codes in byte x+1 of data record 128 (see previous figure).

Table A- 2 Codes for output range

Output range	Coding
Voltage	
±10 V	0000 0000
±5 V	0000 0001
0 to 10 V	0000 0010
1 to 5 V	0000 0011
Current	
±20 mA	0000 0000
0 to 20 mA	0000 0001
4 to 20 mA	0000 0010

Codes for substitute value

The following table contains the codes for the substitute values. You enter these codes in bytes x+4 and x+5 (see previous figure).

Output range	Permissible substitute value
Voltage	
±10 V	-32512 to 32511
±5 V	-32512 to 32511
0 to 10 V	0 to 32511
1 to 5 V	-6912 to 32511
Current	
±20 mA	-29031 to 29030
0 to 20 mA	0 to 29030
4 to 20 mA	-692 to 29376

B

Representation of analog values

This appendix describes the analog values for all output ranges that you can use with the analog module AQ 4xU/I ST.

Measured value resolution

The digitized analog value is the same for all output values at the same nominal range. Analog values are output as fixed point numbers in two's complement.

In the following table, you will find the representation of the binary analog values and the associated decimal or hexadecimal units of the analog values.

The resolutions 14, 15 and 16 bits including sign are shown. Each analog value is entered in the ACCU left-justified. The bits marked with "x" are set to "0".

Table B- 1 Possible resolutions of the analog values

Resolution in bits	Values		Analog value	
	Decimal	Hexadecimal	High byte	Low byte
14	4	4H	Sign 0 0 0 0 0 0 0	0 0 0 0 0 1 x x
15	2	2H	Sign 0 0 0 0 0 0 0	0 0 0 0 0 0 1 x
16	1	1H	Sign 0 0 0 0 0 0 0	0 0 0 0 0 0 0 1

B.1 Representation of output ranges

In the following tables, you can find the digitized representation of the bipolar and unipolar range output ranges. The resolution is 16 bits.

Table B- 2 Bipolar output ranges

Dec. value	Output value in %	Data word																Range
		2 ¹⁵	2 ¹⁴	2 ¹³	2 ¹²	2 ¹¹	2 ¹⁰	2 ⁹	2 ⁸	2 ⁷	2 ⁶	2 ⁵	2 ⁴	2 ³	2 ²	2 ¹	2 ⁰	
≥ 32512	117.589	0	1	1	1	1	1	1	0	1	1	1	1	1	1	1	1	Maximum output value
32511	117.589	0	1	1	1	1	1	1	0	1	1	1	1	1	1	1	1	Overrange
27649	100.004	0	1	1	0	1	1	0	0	0	0	0	0	0	0	0	1	
27648	100.000	0	1	1	0	1	1	0	0	0	0	0	0	0	0	0	0	Nominal range
1	0.003617	0	0	0	0	0	0	0	0	0	0	0	0	0	0	0	1	
0	0.000	0	0	0	0	0	0	0	0	0	0	0	0	0	0	0	0	
-1	-0.003617	1	1	1	1	1	1	1	1	1	1	1	1	1	1	1	1	
-27648	-100.000	1	0	0	1	0	1	0	0	0	0	0	0	0	0	0	0	Underrange
-27649	100.004	1	0	0	1	0	0	1	1	1	1	1	1	1	1	1	1	
-32512	-117.593	1	0	0	0	0	0	0	1	0	0	0	0	0	0	0	0	
≤ -32513	-117.593	1	0	0	0	0	0	0	1	0	0	0	0	0	0	0	0	Minimum output value

Table B- 3 Unipolar output ranges

Dec. value	Output value in %	Data word																Range
		2 ¹⁵	2 ¹⁴	2 ¹³	2 ¹²	2 ¹¹	2 ¹⁰	2 ⁹	2 ⁸	2 ⁷	2 ⁶	2 ⁵	2 ⁴	2 ³	2 ²	2 ¹	2 ⁰	
≥ 32512	117.589	0	1	1	1	1	1	1	1	x	x	x	x	x	x	x	x	Maximum output value
32511	117.589	0	1	1	1	1	1	1	0	1	1	1	1	1	1	1	1	Overrange
27649	100.004	0	1	1	0	1	1	0	0	0	0	0	0	0	0	0	1	
27648	100.000	0	1	1	0	1	1	0	0	0	0	0	0	0	0	0	0	Nominal range
1	0.003617	0	0	0	0	0	0	0	0	0	0	0	0	0	0	0	1	
0	0.000	0	0	0	0	0	0	0	0	0	0	0	0	0	0	0	0	
≤ 0	0	0	0	0	0	0	0	0	0	0	0	0	0	0	0	0	0	Minimum output value

B.2 Representation of analog values in the voltage output ranges

The tables below list the decimal and hexadecimal values (codes) of the possible voltage output ranges.

Table B- 4 Voltage output ranges ± 10 V and ± 5 V

Values			Voltage output range		Range
	Dec.	Hex.	± 10 V	± 5 V	
118.5149 %	32767	7FFF	11.76 V	5.88 V	Overflow*
	32512	7F00			
117.589 %	32511	7EFF	11.76 V	5.88 V	Overrange
	27649	6C01			
100 %	27648	6C00	10 V	5 V	Nominal range
75 %	20736	5100	7.5 V	3.75 V	
0.003617 %	1	1	361.7 μ V	180.8 μ V	
0 %	0	0	0 V	0 V	
	-1	FFFF	-361.7 μ V	-180.8 μ V	
-75 %	-20736	AF00	-7.5 V	-3.75 V	
-100 %	-27648	9400	-10 V	-5 V	
	-27649	93FF			
-117.593 %	-32512	8100	-11.76 V	-5.88 V	Underflow*
	-32513	80FF			
-118.519 %	-32768	8000			

* outputs positive maximum value or negative minimum value

Table B- 5 Voltage output range 0 V to 10 V

Values			Voltage output range		Range
	Dec.	Hex.	0 to 10 V		
118.519 %	32767	7FFF	11.76 V		Overflow*
	32512	7F00			
117.589 %	32511	7EFF	11.76 V		Overrange
	27649	6C01			
100 %	27648	6C00	10 V		Nominal range
75 %	20736	5100	7.5 V		
0.003617 %	1	1	361.7 μ V		
0 %	0	0	0 V		
	-1	FFFF	0 V		
-118.519 %	-32768	8000			

* outputs positive maximum value or negative minimum value

Table B- 6 Voltage output range 1 V to 5 V

Values			Voltage output range	Range
	Dec.	Hex.	1 to 5 V	
118.519 %	32767	7FFF	5.70 V	Overflow*
	32512	7F00		
117.589 %	32511	7EFF	5.70 V	Overrange
	27649	6C01		
100 %	27648	6C00	5 V	Nominal range
75 %	20736	5100	4 V	
0.003617 %	1	1	1 V + 144.7 μ V	
0 %	0	0	1 V	
	-1	FFFF	1 V - 144.7 μ V	
-25 %	-6912	E500	0 V	Underrange
	-6913	E4FF	0 V	
-118.519 %	-32768	8000		

* outputs positive maximum value or negative minimum value

B.3 Representation of analog values in the current output ranges

The tables below list the decimal and hexadecimal values (codes) of the possible current output ranges.

Table B- 7 Current output range ± 20 mA

Values			Current output range	Range
	Dec.	Hex.	± 20 mA	
118.5149 %	32767	7FFF	21 mA	Overflow*
	29031	7167		
105 %	29030	7166	21 mA	Overrange
	27649	6C01	20 mA + 723.4 nA	
100 %	27648	6C00	20 mA	Nominal range
75 %	20736	5100	15 mA	
0.003617 %	1	1	723.4 nA	
0 %	0	0	0 mA	
	-1	FFFF	-723.4 nA	
-75 %	-20736	AF00	-15 mA	
-100 %	-27648	9400	-20 mA	
	-27649	93FF	-20 mA + 723.4 nA	
-105 %	-29031	8E99	-21 mA	Underrange
	-29032	8E98	-21 mA	
-118.519 %	-32768	8000		Underflow*

* outputs positive maximum value or negative minimum value

Table B- 8 Current output range 0 to 20 mA

Values			Current output range	Range	
	Dec.	Hex.	0 to 20 mA		
118.5149 %	32767	7FFF	21 mA	Overflow*	
	29031	7167			
105 %	29030	7166	21 mA	Overrange	
	27649	6C01	20 mA + 723.4 nA		
100 %	27648	6C00	20 mA	Nominal range	
75 %	20736	5100	15 mA		
0.003617 %	1	1	723.4 nA		
0 %	0	0	0 mA		
	-1	FFFF	0 mA		
-118.519 %	-32768	8000			Underflow*

* outputs positive maximum value or negative minimum value

Table B- 9 Current output ranges 4 to 20 mA

Values			Current output range	Range
	Dec.	Hex.	4 to 20 mA	
118.5149 %	32767	7FFF	21 mA	Overflow*
	29377	72C1		
106.25 %	29376	72C0	21 mA	Overrange
	27649	6C01	20 mA + 578.7 nA	
100 %	27648	6C00	20 mA	Nominal range
75 %	19008	4A40	16 mA	
0.003617 %	1	1	4 mA + 578.7 nA	
0 %	0	0	4 mA	
	-1	FFFF	3.9995 mA	Underrange
-2.5 %	-692	FD4C	3.6 mA	
	-693	FD4B	3.6 mA	Underflow*
-118.519 %	-32768	8000		

* outputs positive maximum value or negative minimum value